

# Weldanpower® 125

For use with Equipment having Code Numbers : 10158, 10160, 11183, 11406



This manual covers equipment which is no longer in production by The Lincoln Electric Co. Specifications and availability of optional features may have changed.

## Safety Depends on You

Lincoln arc welding and cutting equipment is designed and built with safety in mind. However, your overall safety can be increased by proper installation ... and thoughtful operation on your part. **DO NOT INSTALL, OPERATE OR REPAIR THIS EQUIPMENT WITHOUT READING THIS MANUAL AND THE SAFETY PRECAUTIONS CONTAINED THROUGHOUT.** And, most importantly, think before you act and be careful.

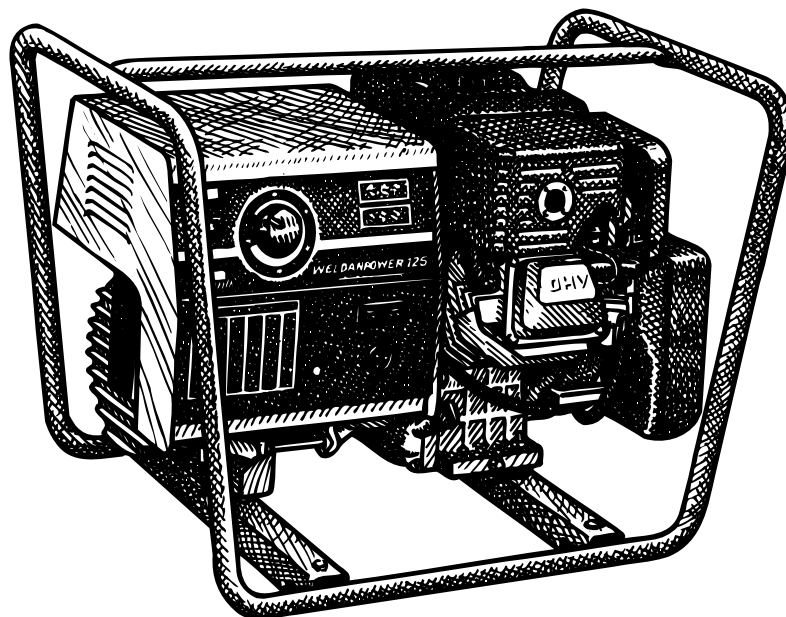

## OPERATOR'S MANUAL

**LINCOLN**®  
**ELECTRIC**

Copyright © 2006 Lincoln Global Inc.

- World's Leader in Welding and Cutting Products •
- Sales and Service through Subsidiaries and Distributors Worldwide •

Cleveland, Ohio 44117-1199 U.S.A. TEL: 216.481.8100 FAX: 216.486.1751 WEB SITE: [www.lincolnelectric.com](http://www.lincolnelectric.com)

## ⚠ WARNING

### ⚠ CALIFORNIA PROPOSITION 65 WARNINGS ⚠

Diesel engine exhaust and some of its constituents are known to the State of California to cause cancer, birth defects, and other reproductive harm.

The Above For Diesel Engines

The engine exhaust from this product contains chemicals known to the State of California to cause cancer, birth defects, or other reproductive harm.

The Above For Gasoline Engines

**ARC WELDING CAN BE HAZARDOUS. PROTECT YOURSELF AND OTHERS FROM POSSIBLE SERIOUS INJURY OR DEATH. KEEP CHILDREN AWAY. PACEMAKER WEARERS SHOULD CONSULT WITH THEIR DOCTOR BEFORE OPERATING.**

Read and understand the following safety highlights. For additional safety information, it is strongly recommended that you purchase a copy of "Safety in Welding & Cutting - ANSI Standard Z49.1" from the American Welding Society, P.O. Box 351040, Miami, Florida 33135 or CSA Standard W117.2-1974. A Free copy of "Arc Welding Safety" booklet E205 is available from the Lincoln Electric Company, 22801 St. Clair Avenue, Cleveland, Ohio 44117-1199.

**BE SURE THAT ALL INSTALLATION, OPERATION, MAINTENANCE AND REPAIR PROCEDURES ARE PERFORMED ONLY BY QUALIFIED INDIVIDUALS.**



### FOR ENGINE powered equipment.

1.a. Turn the engine off before troubleshooting and maintenance work unless the maintenance work requires it to be running.



1.b. Operate engines in open, well-ventilated areas or vent the engine exhaust fumes outdoors.



1.c. Do not add the fuel near an open flame welding arc or when the engine is running. Stop the engine and allow it to cool before refueling to prevent spilled fuel from vaporizing on contact with hot engine parts and igniting. Do not spill fuel when filling tank. If fuel is spilled, wipe it up and do not start engine until fumes have been eliminated.



1.d. Keep all equipment safety guards, covers and devices in position and in good repair. Keep hands, hair, clothing and tools away from V-belts, gears, fans and all other moving parts when starting, operating or repairing equipment.

1.e. In some cases it may be necessary to remove safety guards to perform required maintenance. Remove guards only when necessary and replace them when the maintenance requiring their removal is complete. Always use the greatest care when working near moving parts.

1.f. Do not put your hands near the engine fan. Do not attempt to override the governor or idler by pushing on the throttle control rods while the engine is running.

1.g. To prevent accidentally starting gasoline engines while turning the engine or welding generator during maintenance work, disconnect the spark plug wires, distributor cap or magneto wire as appropriate.



1.h. To avoid scalding, do not remove the radiator pressure cap when the engine is hot.

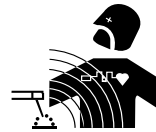

### ELECTRIC AND MAGNETIC FIELDS may be dangerous

2.a. Electric current flowing through any conductor causes localized Electric and Magnetic Fields (EMF). Welding current creates EMF fields around welding cables and welding machines

2.b. EMF fields may interfere with some pacemakers, and welders having a pacemaker should consult their physician before welding.

2.c. Exposure to EMF fields in welding may have other health effects which are now not known.

2.d. All welders should use the following procedures in order to minimize exposure to EMF fields from the welding circuit:

2.d.1. Route the electrode and work cables together - Secure them with tape when possible.

2.d.2. Never coil the electrode lead around your body.

2.d.3. Do not place your body between the electrode and work cables. If the electrode cable is on your right side, the work cable should also be on your right side.

2.d.4. Connect the work cable to the workpiece as close as possible to the area being welded.

2.d.5. Do not work next to welding power source.

Mar '95



## ELECTRIC SHOCK can kill.

- 3.a. The electrode and work (or ground) circuits are electrically "hot" when the welder is on. Do not touch these "hot" parts with your bare skin or wet clothing. Wear dry, hole-free gloves to insulate hands.
- 3.b. Insulate yourself from work and ground using dry insulation. Make certain the insulation is large enough to cover your full area of physical contact with work and ground.
- In addition to the normal safety precautions, if welding must be performed under electrically hazardous conditions (in damp locations or while wearing wet clothing; on metal structures such as floors, gratings or scaffolds; when in cramped positions such as sitting, kneeling or lying, if there is a high risk of unavoidable or accidental contact with the workpiece or ground) use the following equipment:**
- Semiautomatic DC Constant Voltage (Wire) Welder.
  - DC Manual (Stick) Welder.
  - AC Welder with Reduced Voltage Control.
- 3.c. In semiautomatic or automatic wire welding, the electrode, electrode reel, welding head, nozzle or semiautomatic welding gun are also electrically "hot".
- 3.d. Always be sure the work cable makes a good electrical connection with the metal being welded. The connection should be as close as possible to the area being welded.
- 3.e. Ground the work or metal to be welded to a good electrical (earth) ground.
- 3.f. Maintain the electrode holder, work clamp, welding cable and welding machine in good, safe operating condition. Replace damaged insulation.
- 3.g. Never dip the electrode in water for cooling.
- 3.h. Never simultaneously touch electrically "hot" parts of electrode holders connected to two welders because voltage between the two can be the total of the open circuit voltage of both welders.
- 3.i. When working above floor level, use a safety belt to protect yourself from a fall should you get a shock.
- 3.j. Also see Items 6.c. and 8.



## ARC RAYS can burn.

- 4.a. Use a shield with the proper filter and cover plates to protect your eyes from sparks and the rays of the arc when welding or observing open arc welding. Headshield and filter lens should conform to ANSI Z87.1 standards.
- 4.b. Use suitable clothing made from durable flame-resistant material to protect your skin and that of your helpers from the arc rays.
- 4.c. Protect other nearby personnel with suitable, non-flammable screening and/or warn them not to watch the arc nor expose themselves to the arc rays or to hot spatter or metal.



## FUMES AND GASES can be dangerous.

- 5.a. Welding may produce fumes and gases hazardous to health. Avoid breathing these fumes and gases. When welding, keep your head out of the fume. Use enough ventilation and/or exhaust at the arc to keep fumes and gases away from the breathing zone. **When welding with electrodes which require special ventilation such as stainless or hard facing (see instructions on container or MSDS) or on lead or cadmium plated steel and other metals or coatings which produce highly toxic fumes, keep exposure as low as possible and below Threshold Limit Values (TLV) using local exhaust or mechanical ventilation. In confined spaces or in some circumstances, outdoors, a respirator may be required. Additional precautions are also required when welding on galvanized steel.**
5. b. The operation of welding fume control equipment is affected by various factors including proper use and positioning of the equipment, maintenance of the equipment and the specific welding procedure and application involved. Worker exposure level should be checked upon installation and periodically thereafter to be certain it is within applicable OSHA PEL and ACGIH TLV limits.
- 5.c. Do not weld in locations near chlorinated hydrocarbon vapors coming from degreasing, cleaning or spraying operations. The heat and rays of the arc can react with solvent vapors to form phosgene, a highly toxic gas, and other irritating products.
- 5.d. Shielding gases used for arc welding can displace air and cause injury or death. Always use enough ventilation, especially in confined areas, to insure breathing air is safe.
- 5.e. Read and understand the manufacturer's instructions for this equipment and the consumables to be used, including the material safety data sheet (MSDS) and follow your employer's safety practices. MSDS forms are available from your welding distributor or from the manufacturer.
- 5.f. Also see item 1.b.

AUG 06

## WELDING SPARKS can cause fire or explosion.

6.a. Remove fire hazards from the welding area. If this is not possible, cover them to prevent the welding sparks from starting a fire.

Remember that welding sparks and hot materials from welding can easily go through small cracks and openings to adjacent areas. Avoid welding near hydraulic lines. Have a fire extinguisher readily available.

- 6.b. Where compressed gases are to be used at the job site, special precautions should be used to prevent hazardous situations. Refer to "Safety in Welding and Cutting" (ANSI Standard Z49.1) and the operating information for the equipment being used.
- 6.c. When not welding, make certain no part of the electrode circuit is touching the work or ground. Accidental contact can cause overheating and create a fire hazard.
- 6.d. Do not heat, cut or weld tanks, drums or containers until the proper steps have been taken to insure that such procedures will not cause flammable or toxic vapors from substances inside. They can cause an explosion even though they have been "cleaned". For information, purchase "Recommended Safe Practices for the Preparation for Welding and Cutting of Containers and Piping That Have Held Hazardous Substances", AWS F4.1 from the American Welding Society (see address above).
- 6.e. Vent hollow castings or containers before heating, cutting or welding. They may explode.
- 6.f. Sparks and spatter are thrown from the welding arc. Wear oil free protective garments such as leather gloves, heavy shirt, cuffless trousers, high shoes and a cap over your hair. Wear ear plugs when welding out of position or in confined places. Always wear safety glasses with side shields when in a welding area.
- 6.g. Connect the work cable to the work as close to the welding area as practical. Work cables connected to the building framework or other locations away from the welding area increase the possibility of the welding current passing through lifting chains, crane cables or other alternate circuits. This can create fire hazards or overheat lifting chains or cables until they fail.
- 6.h. Also see item 1.c.

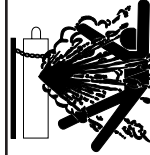

## CYLINDER may explode if damaged.

7.a. Use only compressed gas cylinders containing the correct shielding gas for the process used and properly operating regulators designed for the gas and pressure used. All hoses, fittings, etc. should be suitable for the application and maintained in good condition.

- 7.b. Always keep cylinders in an upright position securely chained to an undercarriage or fixed support.
- 7.c. Cylinders should be located:
  - Away from areas where they may be struck or subjected to physical damage.
  - A safe distance from arc welding or cutting operations and any other source of heat, sparks, or flame.
- 7.d. Never allow the electrode, electrode holder or any other electrically "hot" parts to touch a cylinder.
- 7.e. Keep your head and face away from the cylinder valve outlet when opening the cylinder valve.
- 7.f. Valve protection caps should always be in place and hand tight except when the cylinder is in use or connected for use.
- 7.g. Read and follow the instructions on compressed gas cylinders, associated equipment, and CGA publication P-1, "Precautions for Safe Handling of Compressed Gases in Cylinders," available from the Compressed Gas Association 1235 Jefferson Davis Highway, Arlington, VA 22202.



## FOR ELECTRICALLY powered equipment.

- 8.a. Turn off input power using the disconnect switch at the fuse box before working on the equipment.
- 8.b. Install equipment in accordance with the U.S. National Electrical Code, all local codes and the manufacturer's recommendations.
- 8.c. Ground the equipment in accordance with the U.S. National Electrical Code and the manufacturer's recommendations.

Mar '95

## PRÉCAUTIONS DE SÛRETÉ

Pour votre propre protection lire et observer toutes les instructions et les précautions de sûreté spécifiques qui paraissent dans ce manuel aussi bien que les précautions de sûreté générales suivantes:

### Sûreté Pour Soudage A L'Arc

1. Protégez-vous contre la secousse électrique:
  - a. Les circuits à l'électrode et à la pièce sont sous tension quand la machine à souder est en marche. Éviter toujours tout contact entre les parties sous tension et la peau nue ou les vêtements mouillés. Porter des gants secs et sans trous pour isoler les mains.
  - b. Faire très attention de bien s'isoler de la masse quand on soude dans des endroits humides, ou sur un plancher métallique ou des grilles métalliques, principalement dans les positions assis ou couché pour lesquelles une grande partie du corps peut être en contact avec la masse.
  - c. Maintenir le porte-électrode, la pince de masse, le câble de soudage et la machine à souder en bon et sûr état de fonctionnement.
  - d. Ne jamais plonger le porte-électrode dans l'eau pour le refroidir.
  - e. Ne jamais toucher simultanément les parties sous tension des porte-électrodes connectés à deux machines à souder parce que la tension entre les deux pinces peut être le total de la tension à vide des deux machines.
  - f. Si on utilise la machine à souder comme une source de courant pour soudage semi-automatique, ces précautions pour le porte-électrode s'appliquent aussi au pistolet de soudage.
2. Dans le cas de travail au dessus du niveau du sol, se protéger contre les chutes dans le cas où on recoit un choc. Ne jamais enrouler le câble-électrode autour de n'importe quelle partie du corps.
3. Un coup d'arc peut être plus sévère qu'un coup de soleil, donc:
  - a. Utiliser un bon masque avec un verre filtrant approprié ainsi qu'un verre blanc afin de se protéger les yeux du rayonnement de l'arc et des projections quand on soude ou quand on regarde l'arc.
  - b. Porter des vêtements convenables afin de protéger la peau de soudeur et des aides contre le rayonnement de l'arc.
  - c. Protéger l'autre personnel travaillant à proximité au soudage à l'aide d'écrans appropriés et non-inflammables.
4. Des gouttes de laitier en fusion sont émises de l'arc de soudage. Se protéger avec des vêtements de protection libres de l'huile, tels que les gants en cuir, chemise épaisse, pantalons sans revers, et chaussures montantes.

5. Toujours porter des lunettes de sécurité dans la zone de soudage. Utiliser des lunettes avec écrans latéraux dans les zones où l'on pique le laitier.
6. Eloigner les matériaux inflammables ou les recouvrir afin de prévenir tout risque d'incendie dû aux étincelles.
7. Quand on ne soude pas, poser la pince à un endroit isolé de la masse. Un court-circuit accidentel peut provoquer un échauffement et un risque d'incendie.
8. S'assurer que la masse est connectée le plus près possible de la zone de travail qu'il est pratique de le faire. Si on place la masse sur la charpente de la construction ou d'autres endroits éloignés de la zone de travail, on augmente le risque de voir passer le courant de soudage par les chaînes de levage, câbles de grue, ou autres circuits. Cela peut provoquer des risques d'incendie ou d'échauffement des chaînes et des câbles jusqu'à ce qu'ils se rompent.
9. Assurer une ventilation suffisante dans la zone de soudage. Ceci est particulièrement important pour le soudage de tôles galvanisées plombées, ou cadmiées ou tout autre métal qui produit des fumées toxiques.
10. Ne pas souder en présence de vapeurs de chlore provenant d'opérations de dégraissage, nettoyage ou pistolage. La chaleur ou les rayons de l'arc peuvent réagir avec les vapeurs du solvant pour produire du phosgène (gas fortement toxique) ou autres produits irritants.
11. Pour obtenir de plus amples renseignements sur la sûreté, voir le code "Code for safety in welding and cutting" CSA Standard W 117.2-1974.

## PRÉCAUTIONS DE SÛRETÉ POUR LES MACHINES À SOUDER À TRANSFORMATEUR ET À REDRESSEUR

1. Relier à la terre le châssis du poste conformément au code de l'électricité et aux recommandations du fabricant. Le dispositif de montage ou la pièce à souder doit être branché à une bonne mise à la terre.
2. Autant que possible, l'installation et l'entretien du poste seront effectués par un électricien qualifié.
3. Avant de faire des travaux à l'intérieur de poste, la débrancher à l'interrupteur à la boîte de fusibles.
4. Garder tous les couvercles et dispositifs de sûreté à leur place.

# Thank You

for selecting a **QUALITY** product by Lincoln Electric. We want you to take pride in operating this Lincoln Electric Company product  
 ... as much pride as we have in bringing this product to you!

### **Please Examine Carton and Equipment For Damage Immediately**

When this equipment is shipped, title passes to the purchaser upon receipt by the carrier. Consequently, Claims for material damaged in shipment must be made by the purchaser against the transportation company at the time the shipment is received.

Please record your equipment identification information below for future reference. This information can be found on your machine nameplate.

Product \_\_\_\_\_

Model Number \_\_\_\_\_

Code Number or Date Code \_\_\_\_\_

Serial Number \_\_\_\_\_

Date Purchased \_\_\_\_\_

Where Purchased \_\_\_\_\_

Whenever you request replacement parts or information on this equipment, always supply the information you have recorded above. The code number is especially important when identifying the correct replacement parts.

### **On-Line Product Registration**

- Register your machine with Lincoln Electric either via fax or over the Internet.
- For faxing: Complete the form on the back of the warranty statement included in the literature packet accompanying this machine and fax the form per the instructions printed on it.
- For On-Line Registration: Go to our **WEB SITE at [www.lincolnelectric.com](http://www.lincolnelectric.com)**. Choose "Quick Links" and then "Product Registration". Please complete the form and submit your registration.

**Read this Operators Manual completely** before attempting to use this equipment. Save this manual and keep it handy for quick reference. Pay particular attention to the safety instructions we have provided for your protection. The level of seriousness to be applied to each is explained below:

#### **⚠ WARNING**

This statement appears where the information **must** be followed **exactly** to avoid **serious personal injury or loss of life**.

#### **⚠ CAUTION**

This statement appears where the information **must** be followed to avoid **minor personal injury or damage to this equipment**.

**TABLE OF CONTENTS**

	Page
<b>Safety</b> .....	<b>i-iv</b>
<hr/>	
<b>Installation</b> .....	<b>1-7</b>
Technical Specifications .....	1
Input - Gasoline Engine	
Rated Output - Welder	
Output - Welder and Generator	
Physical Dimensions	
Location and Ventilation.....	2
Storing.....	2
Stacking .....	3
Tilting .....	3
Lifting .....	3
Pre-Operation Engine Service .....	3
Electrical Output Connections.....	4
Machine Grounding.....	5
Plugs and Hand Held Equipment.....	6
Auxiliary Power Receptacles .....	6
Premises Wiring.....	6
Circuit Breakers .....	6
Electrical Device use with the Weldonpower 125.....	7
<hr/>	
<b>Operation</b> .....	<b>9-17</b>
Safety Instructions .....	9
Graphic Symbols.....	10
Product Description.....	11
Recommended Applications .....	11
Operational Features and Controls.....	11
Design Features and Advantages.....	11
Welding Capability .....	11
Limitations.....	11
Controls and Settings.....	12
Engine Operation.....	13-14
Welding Operation .....	14-15
Generator Operation .....	15
Electrode Selection Guide .....	16
Generator Power Applications .....	17
<hr/>	
<b>Accessories</b> .....	<b>18</b>
<hr/>	
<b>Maintenance</b> .....	<b>19-20</b>
Safety Precautions.....	19
Routine and Periodic Maintenance.....	19-20
<hr/>	
<b>Troubleshooting</b> .....	<b>21-24</b>
How To Use Troubleshooting Guide.....	21
Troubleshooting Guide .....	22-24
<hr/>	
<b>Wiring Diagram</b> .....	<b>25, 26</b>
<hr/>	
<b>Dimension Print</b> .....	<b>27</b>
<hr/>	
<b>Parts Manual</b> .....	<b>P-256 Series</b>

# INSTALLATION

## TECHNICAL SPECIFICATIONS - WELDANPOWER 125

INPUT - GASOLINE ENGINE					
<b><u>Manufacturer</u></b>  Briggs & Stratton Vanguard® Model 185432 Two Year Warranty Codes (10158, 10160)	<b><u>Description</u></b>  1 cylinder, 4 cycle air-cooled gasoline driven 9 HP @ 3600 RPM Aluminum Block /w Cast Iron Sleeve	<b><u>Speed</u></b> (Automatic Electronic Idler)  3400 RPM Full Load  3750 RPM High Idle  2400 RPM Low Idle	<b><u>Displacement</u></b>  18.06 cu. in. (296 cc)  <b><u>Bore &amp; Stroke</u></b>  3.15x 2.33 in. (80 x 59 mm)	<b><u>Ignition</u></b>  Manual, Recoil start;  Manual choke  Lifetime ignition warranty	<b><u>Capacities</u></b>  Fuel: 1.6 gal. (6.1 l)  Oil: 1 1/4 qts. (1.2 l)
Robin / Subaru  EX 27  Codes (11183, 11406)	1 cylinder, 4 cycle air-cooled OHC gasoline 9 HP @ 3600 RPM Aluminum Block /w Cast Iron Sleeve	3400 RPM Full Load  3750 RPM High Idle	<b><u>Displacement</u></b>  16.17 cu. in. (265 cc)  <b><u>Bore &amp; Stroke</u></b>  2.95x 2.36 in. (75 x 60 mm)	Manual, Recoil start;  Manual choke	Fuel: 1.6 gal. (6.1 l)  Oil: 1 .1 qts. (1.0 l)
RATED OUTPUT - WELDER					
<b><u>Duty Cycle</u></b>		<b><u>Amps</u></b>		<b><u>Volts at Rated Amperes</u></b>	
30%		125 amps DC Constant Current		25 VDC	
60%		100 amps DC Constant Current			
OUTPUT - WELDER AND GENERATOR					
<b><u>Welding Ranges</u></b>		<b><u>Welder Open Circuit Voltage</u></b>		<b><u>AC Auxiliary Power</u></b>	
50 - 125 Amps DC		80 VDC Max.		4500 Watts 115/230V 1PH 100 % Duty Cycle (Codes 10158, 10160)	
				5500 Surge Watts 4250 Continuous Watts 120 / 240 V 1PH (Codes 11183, 11406)	
PHYSICAL DIMENSIONS					
<b><u>Height</u></b>		<b><u>Width</u></b>		<b><u>Depth</u></b>	
21.13 in.		20.0 in.		30.0 in.	
530 mm		508 mm		762 mm	
				Codes 10158, 10160 190 lbs (86.4kg)	
				(Codes 11183, 11406) 180 lbs (81.7 kg)	
OPERATING TEMPERATURE RANGE			STORAGE TEMPERATURE RANGE		
0° F TO 104° F (-18° C TO 40° C)			-40° F TO 131° F (-40° C TO 55° C)		



# INSTALLATION

Read this entire installation section before you start installation.

## Safety Precautions

### WARNING

Do not attempt to use this equipment until you have thoroughly read all operating and maintenance manuals supplied with your machine. They include important safety precautions, detailed engine starting, operating and maintenance instructions, and parts lists.

## Hazards of Electric Shock, Engine Exhaust & Moving Parts

### WARNING

**ELECTRIC SHOCK can kill.**



- Do not touch electrically live parts or electrode with skin or wet clothing.
- Insulate yourself from work and ground.
- Always wear dry insulating gloves.

**ENGINE EXHAUST can kill.**



- Use in open, well ventilated areas or vent exhaust outside.
- Do not stack anything on or near the engine.

**MOVING PARTS can injure.**



- Do not operate with doors open or guards off.
- Stop engine before servicing.
- Keep away from moving parts.

Only qualified personnel should install, use, or service this equipment.

## LOCATION AND VENTILATION

Whenever you use the Weldanpower® 125, be sure that clean cooling air can flow around the machine's gasoline engine and the generator. Avoid dusty, dirty areas. Also, keep the machine away from heat sources. Do not place the back end of the generator anywhere near hot engine exhaust from another machine. And of course, make sure that engine exhaust is ventilated to an open, outside area.

The Weldanpower 125 must be used outdoors. Do not set the machine in puddles or otherwise submerge it in water. Such practices pose safety hazards and cause improper operation and corrosion of parts.

Always operate the Weldanpower 125 with the case roof on and all machine components completely assembled. This will help to protect you from the dangers of moving parts, hot metal surfaces, and live electrical devices.

## STORING

1. Store the machine in a cool, dry place when it is not in use. Protect it from dust and dirt. Keep it where it can not be accidentally damaged from construction activities, moving vehicles and other hazards.
2. If you will be storing the machine for over 30 days, you should drain the fuel to protect fuel system and carburetor parts from gum deposits. Empty all fuel from the tank and run the engine until it stops from lack of fuel.

(For Codes 10158, 10160)

3. You can store the machine for up to 24 months if you use Briggs & Stratton Gasoline Additive, Part No. 5041 (available from any Authorized Briggs & Stratton Service Center), in the fuel system. Mix the additive with the fuel in the tank and run the engine for a short time to circulate the additive through the carburetor.

(For Codes 11183, 11406)

- 3a. You can store the machine for up to 24 months if you use a stabilizing Additive in the fuel system. Mix the additive with the fuel in the tank and run the engine for a short time to circulate the additive through the carburetor.
4. While the engine is still warm, drain the oil and refill with fresh 10W30 oil.
5. Remove the spark plug and pour approximately 1/2 ounce (15ml) of engine oil into the cylinder. Replace the spark plug and crank the engine slowly to distribute the oil.
6. Clean any dirt and debris from the cylinder and cylinder head fins and housing, rotating screen, and muffler areas.
7. Store in a clean, dry area.

# INSTALLATION

## STACKING

Weldanpower 125 machines CANNOT be stacked.

## TILTING

Place the machine on a secure, level surface whenever you use it or store it. Any surfaces you place it on other than the ground must be firm, non-skid, and structurally sound.

The gasoline engine is designed to run in a level position for best performance. It can operate at an angle, but this should never be more than 15 degrees in any direction. If you do operate it at a slight angle, be sure to check the oil regularly and keep the oil level full. Also, fuel capacity will be a little less at an angle.

## LIFTING

The Weldanpower 125 should be lifted by two people. (See Specification section for weight). Its welded tube roll cage is designed to make lifting easier.

## PRE-OPERATION ENGINE SERVICE

Read and understand the engine operating and maintenance instructions supplied with this machine before you operate the Weldanpower 125.

### WARNING

- Keep hands away from muffler or HOT engine parts.
- Stop the engine when fueling.
- Do not smoke when fueling.
- Remove fuel cap slowly to release pressure.
- Do not overfill tank.
- Wipe up spilled fuel and allow fumes to clear before starting engine.
- Keep sparks and flame away from tank.

## Oil

The Weldanpower 125 is shipped with the engine filled with SAE 10W30 oil. **CHECK THE OIL LEVEL BEFORE YOU START THE ENGINE.** This is an added precaution. Do not screw in dipstick when checking oil level. **DO NOT OVERFILL.** Be sure the fill plug is tight after servicing.

## Fuel

Fill the fuel tank with clean, fresh, regular grade (minimum 85 octane for codes 10158, 10160 and 87 octane for codes 11183, 11406) lead free gasoline. **DO NOT MIX OIL WITH GAS.** The Weldanpower 125 capacity is approximately 1.6 gallons (6.1 Liter). **DO NOT OVERFILL,** allow room in the fuel tank for fuel expansion.

## Spark Arrester

(For Codes 10158, 10160)





Some federal, state or local laws may require gasoline engines to be equipped with exhaust spark arresters when they are operated in certain locations where unarrested sparks may present a fire hazard. The standard mufflers & deflectors included with this machine do not qualify as spark arresters. When required by local regulations, a suitable spark arrester (available from Briggs & Stratton) must be installed and properly maintained.

(For Code 11183, 11406)

Some federal, state or local laws may require gasoline engines to be equipped with exhaust spark arresters when they are operated in certain locations where unarrested sparks may present a fire hazard. The standard muffler included with this machine does qualify as a spark arrester.

### CAUTION

An incorrect additional arrester may lead to damage to the engine or adversely affect performance.

 <b>WARNING</b>		<b>GASOLINE FUEL ONLY</b>			
 <p><b>GASOLINE</b> can cause fire or explosion</p>	<ul style="list-style-type: none"><li>• Stop engine when fueling.</li><li>• Do not smoke when fueling.</li><li>• Keep sparks and flame away from tank.</li><li>• Do not leave unattended while fueling.</li><li>• Wipe up spilled fuel and allow fumes to clear before starting engine.</li><li>• Do not overfill tank, fuel expansion may cause overflow.</li><li>• Close fuel shut off valve when transporting or not operating machine.</li></ul>	 <p><b>ENGINE EXHAUST</b> can kill</p>	<ul style="list-style-type: none"><li>• Use in open, well ventilated area or vent exhaust outside.</li></ul>	 <p><b>MOVING PARTS</b> can injure</p>	<ul style="list-style-type: none"><li>• Keep away from moving parts.</li><li>• Do not operate with panels open or guards off.</li></ul>
		S19799 VM			

# INSTALLATION

## FIGURE A.1 and A.1a - WELDANPOWER 125 OUTPUT CONNECTIONS

FIGURE A.1

FIGURE A.1a

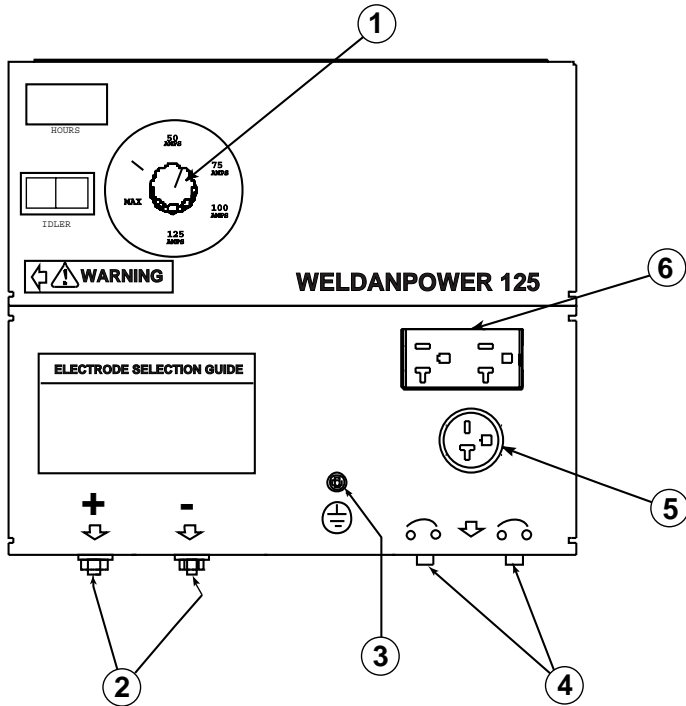

(For Codes 10158, 10160)

1. CURRENT CONTROL DIAL
2. WELD OUTPUT TERMINALS (2)
3. GROUND STUD
4. CIRCUIT BREAKERS (2) - 20 AMP
5. RECEPTACLE - 230 VOLT, 20 AMP
6. DUPLEX RECEPTACLE - 115 VOLT, 20 AMP

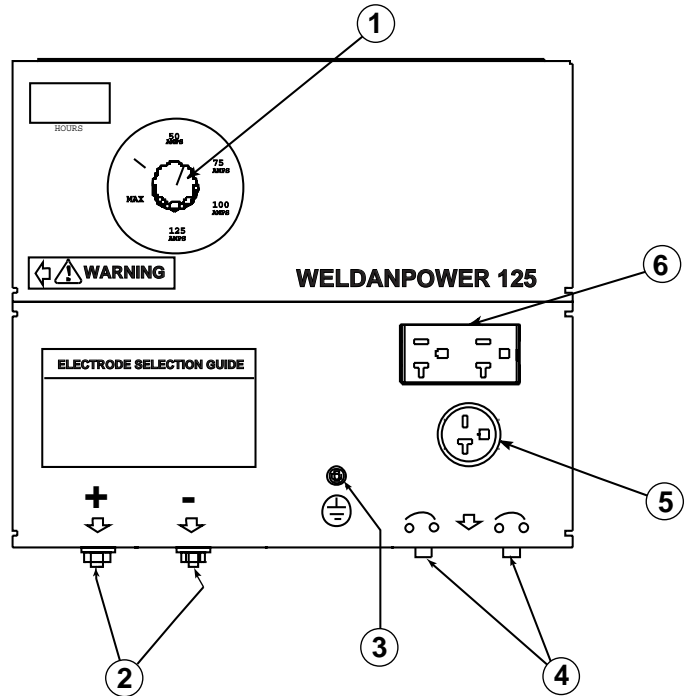

(For Code 11183, 11406)

1. CURRENT CONTROL DIAL
2. WELD OUTPUT TERMINALS (2)
3. GROUND STUD
4. CIRCUIT BREAKERS (2) - 20 AMP
5. RECEPTACLE - 240 VOLT, 20 AMP
6. DUPLEX RECEPTACLE - 120 VOLT, 20 AMP

### ELECTRICAL OUTPUT CONNECTIONS

(For Codes 10158, 10160)

See Figure A.1 for the location of the current control dial, weld output terminals, ground stud, circuit breakers, 230 and 115 volt receptacles.

(For Code 11183, 11406)

See Figure A.1a for the location of the current control dial, weld output terminals, ground stud, circuit breakers, 240 and 120 volt receptacles.

### WELDING CABLE CONNECTIONS

#### Cable Size and Length

Be sure to use welding cables that are large enough. The correct size and length becomes especially important when you are welding at a distance from the welder.

Table A.1 lists recommended cable sizes and lengths for rated current and duty cycle. Length refers to the distance from the welder to the work and back to the welder. Cable diameters are increased for long cable lengths to reduce voltage drops.

**TABLE A.1  
RECOMMENDED WELDING CABLE  
SIZE AND LENGTH**

TOTAL COMBINED LENGTH OF ELECTRODE AND WORK CABLES	
Cable Length	125 Amps 30% Duty Cycle
0-50 ft (0-15m)	6 AWG
50-100 ft (15-30 m)	5 AWG
100-150 ft (30-46 m)	3 AWG
150-200 ft (46-61 m)	2 AWG
200-250 ft (61-76m)	1 AWG

# INSTALLATION

## Cable Installation

Install the welding cables to your Weldonpower 125 as follows. See Figure A.1 for the location of parts.

1. The gasoline engine must be OFF to install welding cables.
2. Remove the 1/2-13 flanged nuts from the output terminals.
3. Connect the electrode holder and work cables to the weld output terminals. Normally, the electrode cable is connected to the positive (+) output stud.
4. Tighten the flanged nuts securely.
5. Be certain that the metal piece you are welding (the “work”) is securely connected to the work clamp and cable.
6. Check and tighten the connections periodically.

### CAUTION

- Loose connections will cause the output studs to overheat and the studs may eventually melt.
- Do not cross welding cables at output stud connection. Keep isolated and separate from one another.

Lincoln Electric offers a welding accessory kit with #6 welding cables. See the **ACCESSORIES** section of this manual for more information.

For more information on welding, see **WELDING OPERATION** in the **OPERATION** section of this manual.

## MACHINE GROUNDING

Because this portable engine driven welder or generator creates its own power, it is not necessary to connect its frame to an earth ground, unless the machine is connected to premises wiring (your home, shop, etc.).

To prevent dangerous electric shock, other equipment to which this engine driven welder supplies power, must:

- a) be grounded to the frame of the welder using a grounded type plug  
or
- b) be double insulated

When this welder is mounted on a truck or trailer, the machine grounding  stud must be securely connected to the metal frame of the vehicle.

Where this engine driven welder is connected to premises wiring such as that in your home or shop, its frame must be connected to the system earth ground. See further connection instructions in the section entitled **Standby Power Connections** as well as the article on grounding in the latest U.S. National Electrical Code and your local code.

In general if the machine is to be grounded, it should be connected with a #8 or larger copper wire to a solid earth ground such as a metal water pipe going into the ground for at least ten feet and having no insulated joints, or to the metal framework of a building which has been effectively grounded. The U.S. National Electrical Code lists a number of alternate means of grounding electrical equipment. A machine grounding stud marked with the symbol  is provided on the front of the welder.

### WARNING

**DO NOT GROUND MACHINE TO A PIPE WHICH CARRIES EXPLOSIVE OR COMBUSTIBLE MATERIAL.**

# INSTALLATION

## PLUGS AND HAND HELD EQUIPMENT

For further protection against electric shock, any electrical equipment connected to the generator receptacles must use a three-blade, grounded type plug or an Underwriter's Laboratories (UL) approved double insulated tool with a two blade plug.

### WARNING

Never operate this machine with damaged or defective cords. All electrical equipment must be in safe operating condition.

## AUXILIARY POWER RECEPTACLES

The control panel of the Weldonpower 125 features two auxiliary power receptacles:

(For Codes 10158, 10160)

- A 20 amp (15 amp CSA), 115 volt duplex (double outlet) receptacle.
- A 20 amp (15 amp CSA), 230 volt single outlet receptacle.

See Figure A.1

Through these receptacles the machine can supply up to 4,500 watts (3,500 watts CSA) of single-phase 60 Hertz AC power. The machine output voltages meet UL standards and fall within  $\pm 10\%$  of the rated voltage.

(For Codes 11183, 11406)

- A 20 amp, 120 volt duplex (double outlet) receptacle.
- A 20 amp, 240 volt single outlet receptacle.

See Figure A.1a

Through these receptacles the machine can supply up to 5,500 watts surge or 4250 watts continuous of single-phase 60 Hertz AC power. The machine output voltages meet UL standards and fall within  $\pm 10\%$  of the rated voltage.

## PREMISES WIRING

The Weldonpower 125 three-wire, grounded neutral generator allows it to be connected to premises wiring.

### WARNING

Only a licensed, certified, trained electrician should install the machine to a premises or residential electrical system. Be certain that:

- The premises is isolated and no back feeding into the utility system can occur. Certain state and local laws require the premises to be isolated before the generator is linked to the premises. Check your state and local requirements.
- A double pole, double throw transfer switch in conjunction with the properly rated double throw circuit breaker is connected between the generator power and the utility meter.

The Weldonpower 125 does not have a combined 120/240 volt receptacle and cannot be connected to a premises as described in other Lincoln literature.

Remember that the Weldonpower 125 is intended only for backup, intermittent use. It cannot withstand long-term use without proper maintenance. See the **MAINTENANCE** section of this manual for more information.

## CIRCUIT BREAKERS



Auxiliary power is protected by circuit breakers. When the machine is operated in high temperature environments, the breakers may tend to trip at lower loads than normally.

### CAUTION

**NEVER BYPASS THE CIRCUIT BREAKERS. WITHOUT OVERLOAD PROTECTION, THE UNIT COULD OVERHEAT AND/OR CAUSE DAMAGE TO THE EQUIPMENT BEING USED.**

# INSTALLATION

## ⚠ CAUTION

Certain Electrical devices cannot be powered by the Weldanpower 125. See Table A.2

**TABLE A.2**  
**ELECTRICAL DEVICE USE WITH THE WELDANPOWER 125**

Type	Common Electrical Devices	Possible Concerns
Resistive	Heaters, toasters, incandescent light bulbs, electric range, hot pan, skillet, coffee maker.	NONE
Capacitive	TV sets, radios, microwaves, appliances with electrical control	Voltage spikes or high voltage regulation can cause the capacitive elements to fail. Surge protection, transient protection, and additional loading is recommended for 100% fail-safe operation. <b>DO NOT RUN THESE DEVICES WITHOUT ADDITIONAL RESISTIVE TYPE LOADS.</b>
Inductive	Single-phase induction motors, drills, well pumps, grinders, small refrigerators, weed and hedge trimmers	These devices require large current inrush for starting. (See Table B.3, GENERATOR POWER APPLICATIONS, in the OPERATION section of this manual for required starting wattages.) Some synchronous motors may be frequency sensitive to attain maximum output torque, but they <b>SHOULD BE SAFE</b> from any frequency induced failures.
Capacitive / Inductive	Computers, high resolution TV sets, complicated electrical equipment.	An inductive type line conditioner along with transient and surge protection is required, and liabilities still exist. <b>DO NOT USE THESE DEVICES WITH A WELDANPOWER 125.</b>

The Lincoln Electric Company is not responsible for any damage to electrical components improperly connected to a Weldanpower 125.

# NOTES

---

# OPERATION

## OPERATING INSTRUCTIONS

### General Warnings

#### SAFETY INSTRUCTIONS

#### WARNING



##### **ELECTRIC SHOCK** can kill.

- Do not touch electrically live parts or electrode with skin or wet clothing.
- Insulate yourself from work and ground.
- Always wear dry insulating gloves.



##### **FUMES AND GASES** can be dangerous.

- Keep your head out of fumes.
- Use ventilation or exhaust to remove fumes from breathing zone.

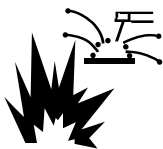

##### **WELDING SPARKS** can cause fire or explosion

- Keep flammable material away.
- Do not weld on containers that have held combustibles.



##### **ARC RAYS** can burn.

- Wear eye, ear and body protection.

#### WARNING



##### **ENGINE EXHAUST** can kill.

- Use in open, well ventilated areas or vent exhaust outside.
- Do not stack anything on or near the engine.



##### **MOVING PARTS** can injure.

- Do not operate with doors open or guards off.
- Stop engine before servicing.
- Keep away from moving parts.

Only qualified personnel should install, use, or service this equipment.

Observe additional Safety Guidelines detailed throughout this manual.



GRAPHIC SYMBOLS USED ON THIS EQUIPMENT OR IN THIS MANUAL



WARNING /  
CAUTION



CHOKE



OIL



AIR CLEANER



FUEL



CIRCUIT  
BREAKER



WORK CLAMP



GROUND  
(AUXILIARY  
POWER)

For Codes 10158, 10160 only.



FAST



ELECTRODE  
WELDING ARC



SLOW

# OPERATION

## PRODUCT DESCRIPTION

The Woldanpower 125 is designed for commercial use welder / generator applications. As a welder it provides 125 amps of DC constant current for welding with DC stick electrodes. A single dial lets you select a full range of welding output from 50 to 125 amps.

(For Codes 10158, 10160)

As a generator it can supply up to 4500 continuous watts of 115 / 230 volt, single-phase AC power. The machine is portable.

A Briggs & Stratton 9 HP Vanguard air cooled, OHV gasoline engine powers the welder / generator. It has an engine warranty of 2 years and a lifetime warranty on the engine ignition system.

(For Codes 11183, 11406)

As a generator it can supply up to 5500 surge watts or 4250 continuous watts of 120 / 240 volt, single-phase AC power. The machine is portable.

A Robin / Subaru 9 HP EX 27 air cooled, OHC gasoline engine powers the welder / generator. It has an engine warranty of 3 years.

## RECOMMENDED APPLICATIONS

### Welder

The Woldanpower 125 provides excellent constant current DC welding output for stick (SMAW) welding.

### Generator

The Woldanpower 125 gives smooth AC generator output for continuous auxiliary power usage within the engine manufacturer's required maintenance recommendations.

## OPERATIONAL FEATURES AND CONTROLS

The Woldanpower 125 was designed for simplicity. Therefore, it has very few operating controls. A single dial on the control panel lets you select either welder or generator use. For welding, the same dial selects continuous current output over the machine's 50 to 125 amp range.

The gasoline engine controls include a recoil starter, choke and stop switch. See ENGINE OPERATION in the OPERATION section of this manual for details about starting, running, stopping, and breaking in the gasoline engine.

## DESIGN FEATURES AND ADVANTAGES

- 125 amp DC constant current welding for stick electrodes.
- Lightweight / portable.
- Full range, continuous welding output control with a single knob.
- Automatic shutdown under low oil level condition.
- Hour Meter Standard.

(For Codes 10158, 10160)

- 4500 Watts of continuous 115 / 230 volt single phase AC auxiliary power (3500 Watts CSA).
- Briggs & Stratton 9 HP Vanguard overhead valve air-cooled gasoline engine. Smooth running, long life.

(For Codes 11183, 11406)

- 5500 Surge watts or 4250 Watts of continuous 120 / 240 volt single phase AC auxiliary power.
- Robin / Subaru 9 HP EX 27 overhead cam air-cooled gasoline engine. Smooth running, long life.

## WELDING CAPABILITY

The Woldanpower 125 is rated 125 amps, 25 VDC at 30% duty cycle on a ten-minute basis. This means that you can load the welder to 125 amps for three minutes out of every ten-minute period. The machine is capable of higher duty cycles at lower output currents. For example, you can load the welder to 100 amps for six minutes out of ten for a 60% duty cycle.

The current is continuously variable from 50 to 125 amps DC. The Woldanpower 125 can, therefore, weld with all 3/32 and most 1/8 inch diameter Lincoln DC electrodes.

## LIMITATIONS

- The Woldanpower 125 is not recommended for any processes besides those that are normally performed using stick welding (SMAW) procedures.
- The Woldanpower 125 is not recommended for pipe thawing.
- During welding, generator power is limited to 100 watts, and output voltages can drop from 120 to 80 volts and 240 to 160 volts. Therefore, DO NOT OPERATE ANY SENSITIVE ELECTRICAL EQUIPMENT WHILE YOU ARE WELDING.

# OPERATION

## CONTROLS AND SETTINGS

All welder/generator controls are located on the

Output Control Panel. Gasoline engine controls are mounted on the engine. See Figure B.1, B.1a and the figures in the engine operation section.

### FIGURE B.1 and B.1a – OUTPUT PANEL CONTROLS

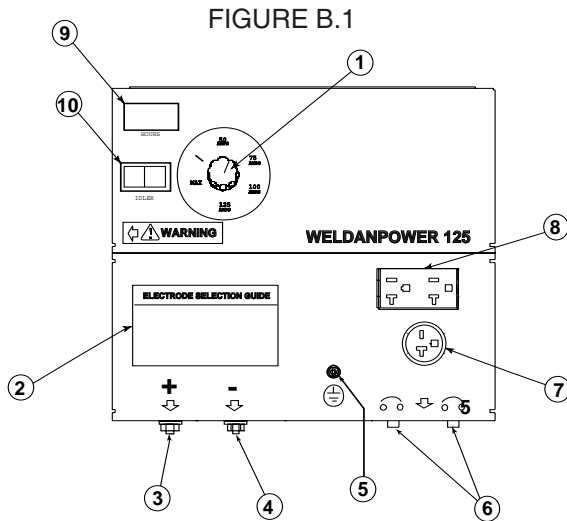

(For Codes 10158, 10160)

1. CURRENT CONTROL DIAL
2. ELECTRODE SELECTION GUIDE
3. WELD POSITIVE OUTPUT TERMINAL
4. WELD NEGATIVE OUTPUT TERMINAL
5. GROUND STUD
6. 20 AMP CIRCUIT BREAKERS (2)
7. 20 AMP, 230 VOLT RECEPTACLE
8. 20 AMP, 115 VOLT DUPLEX RECEPTACLE
9. HOUR METER
10. IDLER SWITCH

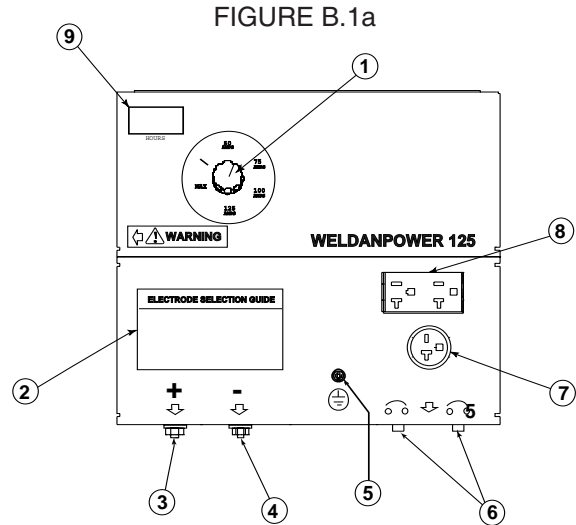

(For Codes 11183, 11406)

1. CURRENT CONTROL DIAL
2. ELECTRODE SELECTION GUIDE
3. WELD POSITIVE OUTPUT TERMINAL
4. WELD NEGATIVE OUTPUT TERMINAL
5. GROUND STUD
6. 20 AMP CIRCUIT BREAKERS (2)
7. 20 AMP, 240 VOLT RECEPTACLE
8. 20 AMP, 1120 VOLT DUPLEX RECEPTACLE
9. HOUR METER

## WELDER/GENERATOR CONTROLS

See Figure B.1 and B.1a for the location of the following features:

1. **CURRENT CONTROL DIAL:** Adjusts continuous current output. The amperages on the dial correspond to the approximate amperages needed for specific Lincoln welding electrodes.
2. **ELECTRODE SELECTION GUIDE:** Provides recommended electrode type, size, and welder output setting based on the thickness of the work.
3. **WELD POSITIVE OUTPUT TERMINAL:** Provides the connection point for either the electrode holder or the work cable. (Because the Wieldanpower 125 is a DC output machine, either output terminal can be used for either cable.)
4. **WELD NEGATIVE OUTPUT TERMINAL:** Provides the connection point for either the electrode holder or the work cable. (Because the Wieldanpower 125 is a DC output machine, either output terminal can be used for either cable.)
5. **GROUND STUD:** Provides a connection point for connecting the machine case to earth ground for the safest grounding procedure.

(For Codes 10158, 10160)

6. **CIRCUIT BREAKERS (2):** Provide separate overload current protection for the 115 volt and 230 volt receptacles.
7. **230 VOLT RECEPTACLE:** Connection point for supplying 230 volt power to operate one electrical device.
8. **115 VOLT DUPLEX RECEPTACLE:** Connection point for supplying 115 volt power to operate one or two electrical devices.
9. **HOUR METER:** Records the time that the engine has run for maintenance purposes.
10. **IDLER SWITCH:** Allows for setting the idle speed of the engine for FAST IDLE or AUTOMATIC IDLE.

(For Codes 11183, 11406)

6. **CIRCUIT BREAKERS (2):** Provide separate overload current protection for the 120 volt and 240 volt receptacles.
7. **240 VOLT RECEPTACLE:** Connection point for supplying 240 volt power to operate one electrical device.
8. **120 VOLT DUPLEX RECEPTACLE:** Connection point for supplying 120 volt power to operate one or two electrical devices.
9. **HOUR METER:** Records the time that the engine has run for maintenance purposes.

# OPERATION

## ENGINE OPERATION

### Engine Control Function/Operation

#### Rocker “Run/Stop” Switch (For Codes 10158, 10160 Only)

The two position “Run/Stop” switch is marked “I” and “O” on the red rocker and is located on the rear of the engine. In the run (I) position, the engine ignition circuit is energized, and the engine can be started by pulling the recoil rope starter. In the stop (O) position, the electronic ignition is grounded, and the engine shuts down.



#### “ON/OFF” Switch (For Codes 11183, 11406)

A two position switch located on the rear of the engine. In the “ON”(I) position, the engine ignition circuit is energized and the engine can be started by pulling the recoil rope starter. In the “OFF”(O) position, the electronic ignition is grounded and the engine shuts down.

#### “Idler Control” Switch (For Codes 10158, 10160 only)

The “idler switch” is located at the upper left of the control panel.

The switch has two positions:

1. In the “high idle” position (  ), the idler is off and the engine runs at the high idle speed controlled by the governor.
2. In the “automatic idle” position (  ) the idler operates as follows:
  - a. When welding or drawing auxiliary power (approximately 100 watts or higher) from the receptacles, the engine operates at full speed.
  - b. When welding ceases or the power load is turned off, the engine will remain at high idle for approximately 12 seconds before automatically shifting to low idle.
  - c. When the welding load or power load is reapplied, the engine will automatically return to high idle speed without delay.

### Starting/Shutdown Instructions

Be sure all Pre-Operation Engine Service has been performed. (See INSTALLATION section)

Remove all loads connected to the AC power receptacles. Before starting, first open the fuel shutoff valve.

Next, move the choke control lever on the engine to the “Chock” position.

Note: For a hot engine leave the chock control lever in the “Run” position.

(For Codes 10158, 10160)

Set the “Idler Control” switch to the automatic position. Place the “Run/Stop” switch on the engine in the run (I) position. To start, pull the starter cord slowly until resistance is felt, then pull the cord rapidly. Slowly move the choke control to the “Run” position (opening the choke) immediately after the engine has started. The engine will go to low idle speed after approximately 12 seconds. Allow the engine to warm up gradually by letting it run at low idle for a few minutes.

(For Codes 11183, 11406)

Place the “On/Off” switch on the engine in the run (I) position. To start, pull the starter cord slowly until resistance is felt, then pull the cord rapidly. Slowly move the choke control to the “Run” position (opening the choke) immediately after the engine has started. Allow the engine to warm up gradually by letting it run at low idle for a few minutes.

### Stopping the Engine

Remove all welding and auxiliary power loads and allow engine to run for a few minutes to cool the engine.

(For Codes 10158, 10160)

Stop the engine by placing the rocker “Run/Stop” switch in the “Stop” (O) position.

(For Codes 11183, 11406)

Stop the engine by placing the “On/Off” switch in the “Off” (O) position. Close the fuel shut off valve.

## WARNING

**Close the fuel valve when the machine is transported to prevent fuel leakage from the carburetor.**

---

# OPERATION

## Break-in Period

It is normal for any engine to use larger quantities of oil until break-in is accomplished. Check the oil level twice a day during the break-in period (about 50 running hours). Change the oil after the first 5 hours of operation. See the Engine Instruction Manual for further details.

### CAUTION

IN ORDER TO ACCOMPLISH THIS BREAK-IN, THE UNIT SHOULD BE SUBJECTED TO MODERATE LOADS, WITHIN THE RATING OF THE MACHINE. AVOID LONG IDLE RUNNING PERIODS. REMOVE LOADS AND ALLOW ENGINE TO COOL SEVERAL MINUTES AT LOW IDLE BEFORE SHUTDOWN.

## Low Oil Sensing

This engine has a built in sensor which responds to low oil level (not pressure). When activated, the system will shut the engine down. The engine will not restart until sufficient oil is added. Check oil level frequently and add oil as required to the full mark on the dipstick. DO NOT OVERFILL.

## Typical Fuel Consumption

(For Codes 10158, 10160)

	BRIGGS & STRATTON 9 H.P. VANGUARD
NO LOAD. 2400 R.P.M.	0.15 GALLONS/HOUR (.57 LITERS/HOUR)
NO LOAD 3750 R.P.M. DC CC WELD OUTPUT 100 AMPS, 25 VOLTS	0.33 GALLONS/HOUR (1.25 LITERS/HOUR) 0.63 GALLONS/HOUR (2.4 LITERS/HOUR)
DC CC WELD OUTPUT 125 AMPS, 25 VOLTS	0.76 GALLONS/HOUR (2.9 LITERS/HOUR)
AUXILIARY POWER 4500 KVA	0.76 GALLONS/HOUR (2.9 LITERS/HOUR)

(For Codes 11183, 11406)

	Robin / Subaru 9 H.P. EX 27
NO LOAD 3750 R.P.M. DC CC WELD OUTPUT 100 AMPS, 25 VOLTS	0.31 GALLONS/HOUR (1.17 LITERS/HOUR) 0.66 GALLONS/HOUR (2.48 LITERS/HOUR)
DC CC WELD OUTPUT 125 AMPS, 25 VOLTS	0.70 GALLONS/HOUR (2.66 LITERS/HOUR)
AUXILIARY POWER 4250 KVA	0.68 GALLONS/HOUR (2.59 LITERS/HOUR)

## WELDING OPERATION GENERAL INFORMATION

### WARNING

**ELECTRIC SHOCK can kill.**



- Do not touch electrically live parts or electrode with skin or wet clothing.
- Insulate yourself from work and ground.
- Always wear dry insulating gloves.

**ENGINE EXHAUST can kill.**



- Use in open, well ventilated areas or vent exhaust outside.
- Do not stack anything on or near the engine.

**MOVING PARTS can injure.**



- Do not operate with doors open or guards off.
- Stop engine before servicing.
- Keep away from moving parts.

**Only qualified personnel should install, use, or service this equipment.**

The Weldonpower 125 can deliver from 50 to 125 amps of welding output current. Output can be adjusted by setting the current control dial on the output control panel.

You can get maximum welding output by setting the dial to 125 AMPS. At high current settings like this, some output may decrease as the machine is used. If you are welding for a long time, you may need to turn the dial slightly upward to maintain the same results.

The numbers on the dial correspond to the approximate amps needed to weld using specific Lincoln welding rods. Table B.2, WELDING APPLICATIONS, or the electrode selection guide on the machine output panel give you the recommended dial settings based on the thickness of the work and the size and type of rod you're using.

### TO USE THE WELDANPOWER 125 FOR WELDING:

1. Remove the flange nuts from the weld output terminals and place the work and electrode welding cables over the terminals. See Figure B.1 and B.1a. Replace and tighten the flange nuts securely. Be sure the connections are tight.

# OPERATION

2. Select the appropriate electrode. See Table B.2 or the ELECTRODE SELECTION GUIDE on the machine Output Control Panel.
3. Attach the work clamp securely to the work you are welding.
4. Insert the electrode into the electrode holder.
5. Set the current control dial to the desired output current.
6. Start the gasoline engine. See **ENGINE OPERATION** in this section of the manual.
7. Strike an arc and begin welding.

## **AFTER YOU FINISH THE WELD:**

1. Stop the gasoline engine. See **ENGINE OPERATION** in this section of the manual.
2. Allow the electrode and work to cool completely.
3. Remove the work clamp from the work.
4. Remove any remaining piece of electrode from the electrode holder.
5. If you are finished using the WELDANPOWER 125 for welding, disconnect the welding cables from the weld output terminals. Reattach the flange nuts and leave them on the terminals.

For DC+ welding, the electrode cable is to be connected to the "+" output stud and work cable to the "-" output stud. (For DC- welding, reverse these connections.)

(For Codes 11183, 11406 Only)

## **Semi-automatic Wire Welding with a Lincoln Wire Feeder/Welder**

The Weldanpower 125 generator power can be used to supply up to 4,250 watts continuous input power to a Lincoln Wire Feeder/Welder. The Wire Feeder/ Welder is equipped with all the supplies needed for Flux-Cored Arc Welding (FCAW). Also some Wire Feeder/Welders come equipped with the essentials needed for Gas Metal Arc Welding (GMAW) or MIG processes, while others require the purchase of a conversion kit. These products are available where Lincoln products are sold. Contact your local authorized Lincoln representative for more details.

(For Codes 11183, 11406 Only)

## **Plasma Cutting with Lincoln Pro-Cut 25.**

The Weldanpower 125 generator power can be used to supply up to 4,250 watts continuous input power to a Pro-Cut 25. The Pro-Cut will work satisfactorily under the following conditions:

1. Set the Rheostat on the Weldanpower 125 to the 125 amp position. (Higher Settings may result in a shutdown of the Pro-Cut 25.)
2. Leave the "ON/OFF" switch on the Pro-Cut "OFF" until the Weldanpower 125 has been started and is at full operating speed.

## **120V Receptacle Operation:**

- Set the Output Control on the Pro-Cut 25 no higher than the 15 amp position. ( Higher settings may cause circuit breaker on the Weldanpower 125 to trip.)
- Maximum material thickness that can be cut is 1/4".

## **240V Receptacle Operation:**

- The Pro-Cut 25 may be used for its full range of control.
- Maximum material thickness that can be cut is 3/8".

(Codes 10158, 10160 Only)

## **Semi-automatic Wire Welding with a Lincoln Wire Feeder/Welder**

The Weldanpower 125 generator power can be used to supply up to 4,500 watts continuous input power to a Lincoln Wire Feeder/Welder. The Wire Feeder/ Welder is equipped with all the supplies needed for Flux-Cored Arc Welding (FCAW). Also some Wire Feeder/Welders come equipped with the essentials needed for Gas Metal Arc Welding (GMAW) or MIG processes, while others require the purchase of a conversion kit. These products are available where Lincoln products are sold. Contact your local authorized Lincoln representative for more details.

(Codes 10158, 10160 Only)

## **Plasma Cutting with Lincoln Pro-Cut 25.**

The Weldanpower 125 generator power can be used to supply up to 4,500 watts continuous input power to a Pro-Cut 25. The Pro-Cut will work satisfactorily under the following conditions:

1. Set the Rheostat on the Weldanpower 125 to the 125 amp position. (Higher Settings may result in a shutdown of the Pro-Cut 25.)
2. Leave the "ON/OFF" switch on the Pro-Cut "OFF" until the Weldanpower 125 has been started and is at full operating speed.

## **115V Receptacle Operation:**

- Set the Output Control on the Pro-Cut 25 no higher than the 15 amp position. ( Higher settings may cause circuit breaker on the Weldanpower 125 to trip.)
- Maximum material thickness that can be cut is 1/4".

## **230V Receptacle Operation:**

- The Pro-Cut 25 may be used for its full range of control.
- Maximum material thickness that can be cut is 3/8".

# OPERATION

## AUXILIARY POWER OPERATION

### WARNING

Be sure that any electrical equipment plugged into the generator AC power receptacles can withstand a  $\pm 10\%$  voltage and a  $\pm 5\%$  frequency variation. Some electronic devices cannot be powered by the WELDANPOWER 125. Refer to Table A.2, ELECTRICAL DEVICE USE WITH THE WELDANPOWER 125, in the INSTALLATION section of this manual.

### GENERAL INFORMATION

(For Codes 10158, 10160)

The WELDANPOWER 125 is rated at 4500 continuous watts (3500 watts CSA). It provides both 115 volt and 230 volt power. You can draw up to 20 amps (15 amps CSA) from either side of the 115 volt duplex receptacle. Up to 20 amps (15 amps CSA) can be drawn from the single 230 volt receptacle.

Electrical loads in watts are calculated by multiplying the voltage rating of the load by the number of amps it draws. (This information is given on the load device nameplate.) For example, a device rated 115 volts, 2 amps will need 230 watts of power ( $115 \times 2 = 230$ ).

(For Codes 11183, 11406)

The WELDANPOWER 125 is rated at 5500 surge watts or 4250 continuous watts. It provides both 120 volt and 240 volt power. You can draw up to 20 amps from either side of the 120 volt duplex receptacle, but not more than 35.4 amps from both sides at once. Up to 17.7 amps can be drawn from the single 240 volt receptacle.

Electrical loads in watts are calculated by multiplying the voltage rating of the load by the number of amps it draws. (This information is given on the load device nameplate.) For example, a device rated 120 volts, 2 amps will need 240 watts of power ( $120 \times 2 = 240$ ).

You can use Table B.3, AUXILIARY POWER APPLICATIONS, to determine the wattage requirements of the most common types of loads you can power with the WELDANPOWER 125. Be sure to read the notes at the bottom of the table.

### TO USE THE WELDANPOWER 125 AS AN AUXILIARY POWER SUPPLY:

1. Start the gasoline engine. See **ENGINE OPERATION** in this section of the manual.
2. Set the current control dial on the output control panel to "MAX." See Figure B.1 and B.1a.

(For Codes 10158, 10160)

3. Plug the load(s) into the appropriate 115 volt or 230 volt power receptacle.

(For Codes 11183, 11406)

3. Plug the load(s) into the appropriate 120 volt or 240 volt power receptacle.

**NOTE:** During welding, the maximum generator output for auxiliary loads is 100 watts.



(For Codes 10158, 10160)

**NOTE:** You can supply multiple loads as long as the total load does not exceed 4,500 watts). Be sure to start the largest loads first.

(For Codes 11183, 11406)

**NOTE:** You can supply multiple loads as long as the total load does not exceed 5,500 surge watts or 4000 continuous watts. Be sure to start the largest loads first.

**TABLE B.2  
ELECTRODE SELECTION GUIDE**

AWS CLASSIFICATION	ELECTRODE TYPE	ELECTRODE POLARITY	CURRENT RANGE (AMPS)		
			 3/32 SIZE	 1/8 SIZE	 5/32 SIZE
E6010	FLEETWELD® 5P	DC+	50-75	75-125	-
E6011	FLEETWELD® 35	DC+	50-75	70-110	80-125
E6011	FLEETWELD® 180	DC+	50-80	55-110	105-125
E6013	FLEETWELD® 37	DC±	70-95	100-125	-
E7018	EXCALIBUR® 7018	DC+	70-100	90-125	-
E7018	JETWELD® LH-73	DC+	65-85	90-125	-
E708-17 & E308L-17	BLUE MAX® 308/308L AC-DC	DC+	50-60	55-95	80-125
ENi-CI	SOFTWELD® 99Ni	DC+	50-80	80-110	-
-	WEARSHIELD® ABR	DC+	-	50-125	-
SHEET THICKNESS			1/8 AND THINNER	1/8 AND THICKER	

S19718  
3-1-91

# OPERATION

**TABLE B.3  
AUXILIARY POWER APPLICATIONS**

<b>Suggested Power Applications</b>	<b>Running Watts (Continuous)</b>	<b>*Start-up Watts (Surge)</b>
*Air Compressor - 1 HP	2,000	4,000 - 8,000
*Air Compressor - 3/4 HP	1,250	3,100 - 5,000
*Airless Sprayer - 1/3 HP	600	1,500 - 2,400
Chain Saw	1,200	
Circular Saw	1,200	
Coffee Maker	1,000	
*Deep Freezer	500	750 - 2,000
*Electric Motor - 1 HP	1,000	2,500 - 4,000
Electric Range (1 element)	1,500	
Electric Skillet	1,250	
*Furnace Fan - 1/3 HP	1,200	3,000 - 4,800
Portable Grinder (4 1/2")	600	
Portable Grinder (7")	2,000	
Halogen Work Light	500	
Hand Drill - 1/4"	500	
Hand Drill - 3/8"	700	
1500 Watt Heater	1,750	
Hedge Trimmer	450	
Light Bulb	100	
Reciprocating Saw	900	
Radial Arm Saw	2,600	
Radio	50	
*Refrigerator/Freezer (small)	600	1,500 - 2,400
Slow Cooker	200	
*Submersible Pump - 1 HP	1,000	2,500 - 4,000
*Sump Pump	600	1,500 - 2,400
Toaster	1,100	
Weed Trimmer	500	
Lincoln Wire Feeder/Welder	4,000	

**NOTES:**

Wattages listed are approximate. Check your equipment for actual wattage.

Equipment with unusually high \*START-UP WATTS are listed. For start-up of other equipment that uses a motor, listed in the table, multiply RUNNING WATTS by 2.

(For Codes 10158, 10160)

Multiple loads can be used as long as the total load does not exceed 4,500 watts. Be sure to start the largest loads first.

(For Codes 11183, 11406)

Multiple loads can be used as long as the total load does not exceed 5,500 surge watts or 4000 continuous watts. Be sure to start the largest loads first.



# ACCESSORIES

---

## OPTIONS/ACCESSORIES

The following options/accessories are available for your WELDANPOWER 125 from your local Lincoln Distributor:

**Accessory Kit (K875)** – Includes the following:

- Twenty feet (6.1 meters) of #6 AWG electrode cable with lug.
- Fifteen feet (4.6 meters) of #6 work cable with lugs.
- Work Clamp
- Headshield with No. 10 filter
- Insulated electrode holder and sample electrodes 150 amp capacity.

**Undercarriage (K882-2)** - A two-wheeled, hand movable undercarriage is available for field installation.

**Rotor Removal Kit (S20925)** - A service kit with thru bolt and impact bolt's for removing the generator rotor from tapered engine crank shaft.

(For Codes 10158 and 10160 only)

## BRIGGS AND STRATTON ACCESSORIES

The following options/accessories are available for your WELDANPOWER 125 from your local Briggs and Stratton Distributor:

**Exhaust Deflector** - Briggs and Stratton Part No. 710281

# MAINTENANCE

## SAFETY PRECAUTIONS

### ⚠ WARNING

- Have qualified personnel do all maintenance and troubleshooting work.
- Turn the engine off before working inside the machine.
- Remove guards only when necessary to perform maintenance and replace them when the maintenance requiring their removal is complete.
- If guards are missing from the machine, get replacements from a Lincoln Distributor. See the EXPLODED VIEW AND PARTS LIST at the back of this manual.

Read the Safety Precautions in the front of this manual and in the Briggs & Stratton or Robin / Subaru **Operating and Maintenance Instructions** manual before working on the WELDANPOWER 125.

Keep all equipment safety guards, covers, and devices in position and in good repair. Keep your hands, hair, clothing, and tools away from the recoil housing, fans, and all other moving parts when starting, operating, or repairing this machine.

## ROUTINE AND PERIODIC MAINTENANCE

### ENGINE MAINTENANCE

### ⚠ CAUTION

To prevent the engine from accidentally starting, disconnect the spark plug lead before servicing the engine.

See the Briggs & Stratton or Robin / Subaru Owner's manual for a summary of maintenance intervals for the engine. Follow either the hourly or the calendar intervals, whichever come first. More frequent service may be required, depending on your specific application and operating conditions. The Briggs & Stratton and Robin / Subaru Owner's manual shows engine maintenance replacement parts and numbers.



**OIL:** Check the oil level after every 5 hours of operation or daily. **BE SURE TO MAINTAIN THE OIL LEVEL.**

Change the oil the first time after 5 hours of operation for Briggs & Stratton, 20 hours for the Robin / Subaru. Then, under normal operating conditions, change the oil after every 50 hours or once a year, whichever occurs first. If the engine is operated under heavy load or in high ambient temperatures, change the oil every 25 hours.

Drain the oil from the drain plug located on either side of the engine bottom, as shown in Figure D.1. Refill through the oil fill plug until the oil reaches the full mark on the dip stick. See Engine Owner's manual for specific oil recommendations.

**FIGURE D.1 - OIL DRAIN AND REFILL LOCATION**

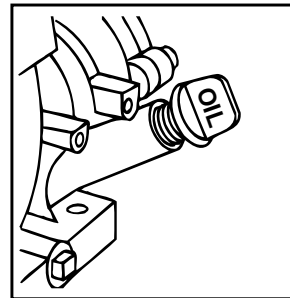

**Do not screw in dipstick to check oil**

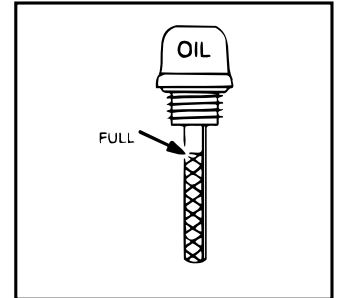

**FILL to FULL mark on dipstick - recheck**

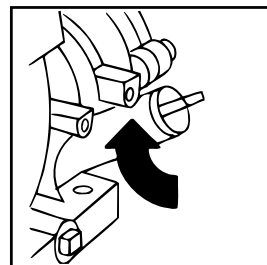

**Tighten dipstick firmly before starting**

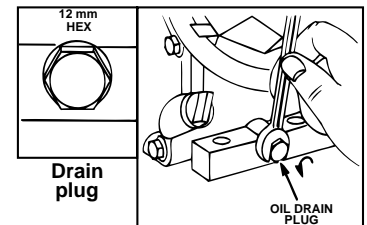

**Oil drain**



**FUEL:** At the end of each day's use, refill the fuel tank to minimize moisture condensation and dirt contamination in the fuel line.



**AIR CLEANER:** With normal operating conditions, the maintenance schedule for cleaning and re-oiling the foam pre-filter is every 25 hours and replacement of the air cleaner filter element every 100 hours.

More frequent servicing is required with dusty operating conditions. Refer to the maintenance section of the Engine Owner's Manual for more information.

# MAINTENANCE

## To service the pre-cleaner:

Remove the wing nuts and cover for Codes 10158, 10160)

Remove the cover for (Codes 11183, 11406). Carefully remove the foam pre-cleaner from the filter element.

1. Wash in liquid detergent and water.
2. Squeeze dry in a clean cloth.
3. Saturate in clean engine oil.
4. Squeeze in a clean, absorbent cloth to remove all excess oil.

Carefully place the pre-cleaner back over the filter element and reinstall the air cleaner cover and wing nuts.

**CLEAN ENGINE:** Remove dirt and debris with a cloth or a brush. Do not clean with a forceful spray of water. Water might contaminate the fuel system. Use low pressure air to blow out the machine periodically. In particularly dirty locations this may be required once a week.

## WARNING

## Engine Adjustments

**OVERSPEED IS HAZARDOUS** - The maximum allowable high idle speed for this machine is 3750 RPM, no load. Do NOT tamper with the governor components or setting or make any other adjustments to increase the maximum speed. Severe personal injury and damage to the machine can result if operated at speeds above maximum.

Adjustments to the engine are to be made only by a Lincoln Service Center or an authorize Field Service Shop.

## Slip Rings

A slight amount of darkening and wear of the slip rings and brushes is normal. Brushes should be inspected

## CAUTION

when a general overhaul is necessary. If brushes are to be replace, clean slip rings with a fine emery paper. Do not attempt to polish slip rings while engine is running.

## Hardware

Both English and Metric fasteners are used in this welder.

## Engine Maintenance Parts

(For Codes 10158, 10160)

	B & S Vanguard® 9 HP
Air Filter Element	B & S 710266
Air Filter Pre-Cleaner	B & S 710268
Spark Plugs (Resistor Type)	B & S 491055 Champion RC12YC Autolite 3924 (Gap .030" [.76mm])

(For Codes 11183, 11406)

	Robin / Subaru
Air Filter Element	279-32616-00
Air Filter Pre-Cleaner	279-32611-00
Spark Plug (Resistor Type)	NGK BR6 HS (Gap .030" [.76mm])

## How To Use Troubleshooting Guide

### **WARNING**

This Troubleshooting Guide is designed to be used by the machine Owner/Operator. Unauthorized repairs performed on this equipment may result in danger to the technician and machine operator and will invalidate your factory warranty. For your safety, please observe all safety notes and precautions detailed in the Safety Section of this manual to avoid electrical shock or danger while troubleshooting this equipment.

---

This Troubleshooting Guide is provided to help you locate and correct possible machine misadjustments. Simply follow the three-step procedure listed below.

#### **Step 1. LOCATE PROBLEM (SYMPTOM)**

Look under the column labeled “PROBLEM (SYMPTOMS)”. This column describes possible symptoms that your machine may exhibit. Find the listing that best describes the symptom that your machine is exhibiting.

#### **Step 2. PERFORM EXTERNAL RECOMMENDED TESTS**

The second column labeled “POSSIBLE AREAS OF MISADJUSTMENT(S)” lists the obvious external possibilities that may contribute to the machine symptom. Perform these tests/checks in the order listed. In general, these tests can be conducted without removing the case wrap-around cover.

#### **Step 3. CONSULT LOCAL AUTHORIZED FIELD SERVICE FACILITY**

If you have exhausted all of the recommended tests in step 2, consult your local Authorized Field Service Facility.

### **CAUTION**

If for any reason you do not understand the test procedures or are unable to perform the tests/repairs safely, contact your local Authorized Field Service Facility for technical troubleshooting assistance before you proceed.

---

# TROUBLESHOOTING

Observe Safety Guidelines detailed in the beginning of this manual.

## Troubleshooting Guide

PROBLEMS (SYMPTOMS)	POSSIBLE AREAS OF MISADJUSTMENT(S)	RECOMMENDED COURSE OF ACTION
<b>OUTPUT PROBLEMS</b>		
Major Physical or Electrical Damage is Evident.	1. Contact your local Lincoln Authorized Field Service Facility	If all recommended possible areas of misadjustment have been checked and the problem persists, <b>Contact your local Lincoln Authorized Field Service Facility.</b>
No generator power or welding output.	<ol style="list-style-type: none"> <li>1. Check brushes for wear. See Maintenance section.</li> <li>2. Check for loose or faulty connections at brush holders.</li> <li>3. Open lead in flashing or field circuit.</li> <li>4. Rheostat (R1) lead broke.</li> <li>5. Dirty slip rings.</li> <li>6. Faulty rheostat (R1).</li> <li>7. Faulty field bridge rectifier (D1).</li> <li>8. Faulty field capacitor (C1).</li> <li>9. Faulty stator field winding.</li> <li>10. Faulty rotor.</li> </ol>	
Generator power is available but unit will not weld.	<ol style="list-style-type: none"> <li>1. Loose connection to output stud.</li> <li>2. Work not connected.</li> <li>3. Electrode holder loose.</li> <li>4. No open circuit voltage at output studs. Open lead in weld circuit.</li> <li>5. Faulty output bridge rectifier.</li> <li>6. Faulty choke (L1).</li> </ol>	
Unit will weld but low or no generator power is available.	<ol style="list-style-type: none"> <li>1. Circuit breaker is open.</li> <li>2. Loose or open connection with electrical plug-in component.</li> <li>3. Current control dial not at "MAX"</li> <li>4. No open circuit voltage at receptacle.</li> </ol>	
No auxiliary power but machine has weld output	1. Check CB1 and CB2 - Reset if tripped.	

### CAUTION

If for any reason you do not understand the test procedures or are unable to perform the tests/repairs safely, contact your local Authorized Field Service Facility for technical troubleshooting assistance before you proceed.

# TROUBLESHOOTING

Observe Safety Guidelines detailed in the beginning of this manual.

## Troubleshooting Guide

PROBLEMS (SYMPTOMS)	POSSIBLE AREAS OF MISADJUSTMENT(S)	RECOMMENDED COURSE OF ACTION
<b>ENGINE PROBLEMS</b>		
Engine will not idle down to low speed. (For Codes 10158, 10160 only.)	<ol style="list-style-type: none"> <li>1. Idler Switch on HIGH Idle.</li> <li>2. Engine choke is not fully open.</li> <li>3. External load on welder or auxiliary power. - Remove load.</li> <li>4. Machine output is under load or idle switch in wrong position.</li> <li>5. Idle solenoid does not pull in.</li> </ol>	<p>If all recommended possible areas of misadjustment have been checked and the problem persists, <b>Contact your local Lincoln Authorized Field Service Facility.</b></p>
Engine idles down to low idle but will not stay at low idle. (For Codes 10158, 10160 only.)	<ol style="list-style-type: none"> <li>1. Engine low idle RPM may be set too low. - Contact Lincoln Field Service Facility.</li> </ol>	
Engine will not go to high idle when attempting to weld or use generator power. (For Codes 10158, 10160 only.)	<ol style="list-style-type: none"> <li>1. Check Work and Electrode cables for loose or faulty connections.</li> <li>2. Mechanical linkage from solenoid to engine stuck.</li> <li>3. Open connection in weld circuit.</li> <li>4. No output from receptacles or load too small.</li> <li>5. Idler pc board is not sensing output current.</li> <li>6. Faulty idler pc board.</li> </ol>	
Engine will not go to high idle when using auxiliary power. (For Codes 10158, 10160 only.)	<ol style="list-style-type: none"> <li>1. Auxiliary load less than 100 watts.</li> <li>2. Circuit breaker CB1 or CB2 tripped or faulty.</li> <li>3. Mechanical linkage from solenoid to engine stuck.</li> </ol>	
Engine runs erratic or stops running or engine surges at low idle. (For Codes 10158, 10160 only.)	<ol style="list-style-type: none"> <li>1. Oil level may be low activating the engine "Oil Gard" shutdown system. - Check oil level.</li> <li>2. Idle solenoid linkage or engine idle misadjusted.</li> </ol>	
Recoil starter is hard to pull.	<ol style="list-style-type: none"> <li>1. Crankcase may be over-filled with oil. - Check oil level.</li> </ol>	
Engine will not start or starts but runs rough with low power.	<ol style="list-style-type: none"> <li>1. Water in engine from rain and / or condensation. - Remove spark plug and dry it if wet. Blow low pressure compressed air in spark plug port while pulling recoil starter. Re-install spark plug.</li> <li>2. Spark plug may be faulty.</li> <li>3. Air filter element saturated with water and / or oil - Replace.</li> </ol>	

### CAUTION

If for any reason you do not understand the test procedures or are unable to perform the tests/repairs safely, contact your local Authorized Field Service Facility for technical troubleshooting assistance before you proceed.

# TROUBLESHOOTING

Observe Safety Guidelines detailed in the beginning of this manual.

## Troubleshooting Guide

PROBLEMS (SYMPTOMS)	POSSIBLE AREAS OF MISADJUSTMENT(S)	RECOMMENDED COURSE OF ACTION
WELDING PROBLEMS		
Engine runs erratically or stops running.	<ol style="list-style-type: none"> <li>1. Engine is not fully warmed-up and engine choke is in the fully open (RUN) position.</li> <li>2. Engine requires service to head, carburetor, filters, oil, spark plug and / or gas.</li> <li>3. Oil level to low.</li> </ol>	<p>If all recommended possible areas of misadjustment have been checked and the problem persists, <b>Contact your local Lincoln Authorized Field Service Facility.</b></p>
Engine sputters but will not start.	<ol style="list-style-type: none"> <li>1. Bad gas, bad filter, air cleaner, spark plug, and/or breather.</li> </ol>	
Recoil starter is hard to pull.	<ol style="list-style-type: none"> <li>1. Too much oil in crankcase.</li> </ol>	
Arc is erratic and “pops out”.	<ol style="list-style-type: none"> <li>1. Check Work and Electrode cables for loose or faulty connection.</li> <li>2. Electrode may be wet.</li> </ol>	

⚠ CAUTION

If for any reason you do not understand the test procedures or are unable to perform the tests/repairs safely, contact your local Authorized Field Service Facility for technical troubleshooting assistance before you proceed.

# WIRING DIAGRAM

## WIRING DIAGRAM - WELDANPOWER 125 (FOR CODES 10158, 10160) BRIGGS AND STRATTON

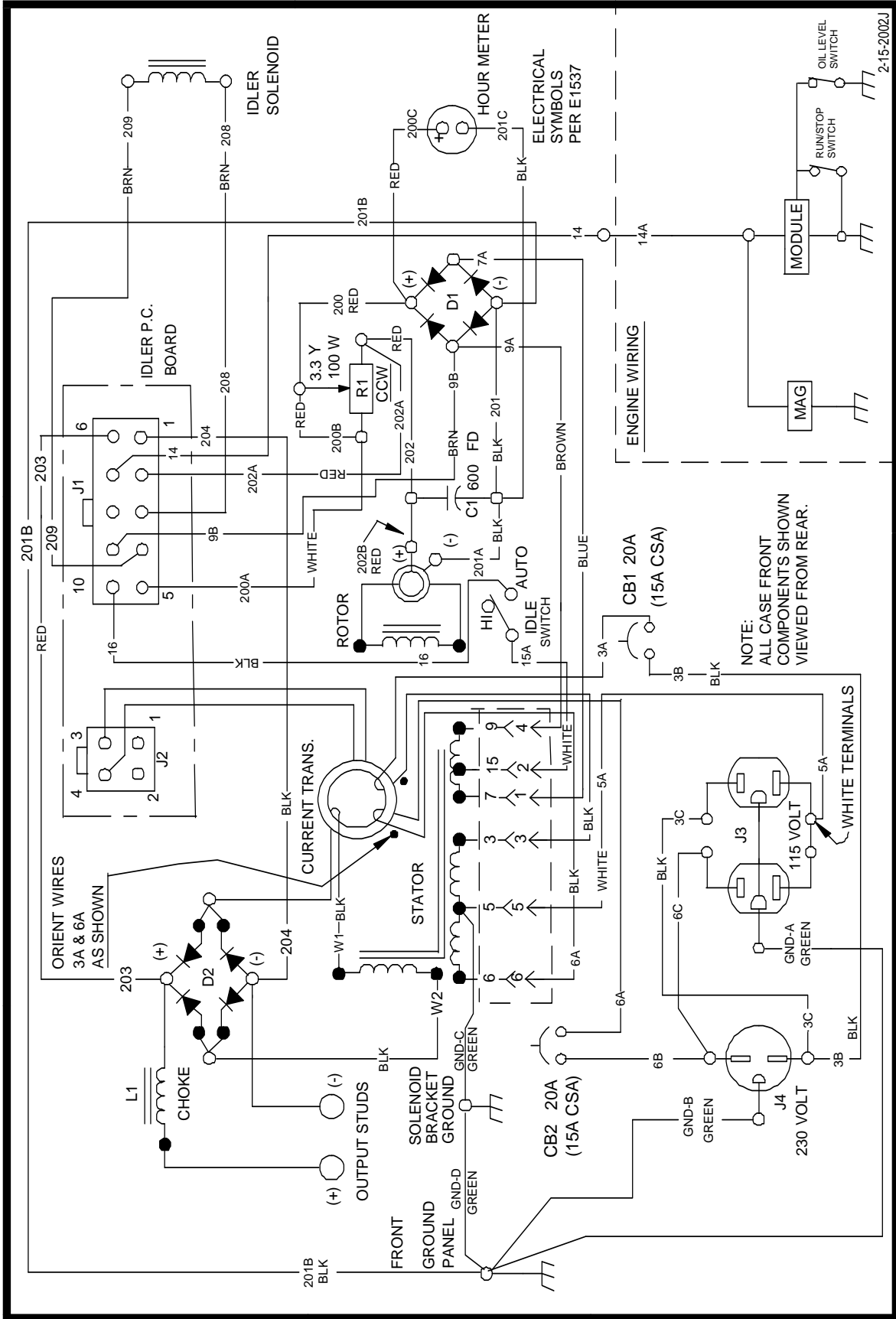

**S21455**

NOTE: This diagram is for reference only. It may not be accurate for all machines covered by this manual. The specific diagram for a particular code is pasted inside the machine on one of the enclosure panels. If the diagram is illegible, write to the Service Department for a replacement. Give the equipment code number..



# WIRING DIAGRAM

## WIRING DIAGRAM - WELDANPOWER 125 (FOR CODE 11183)

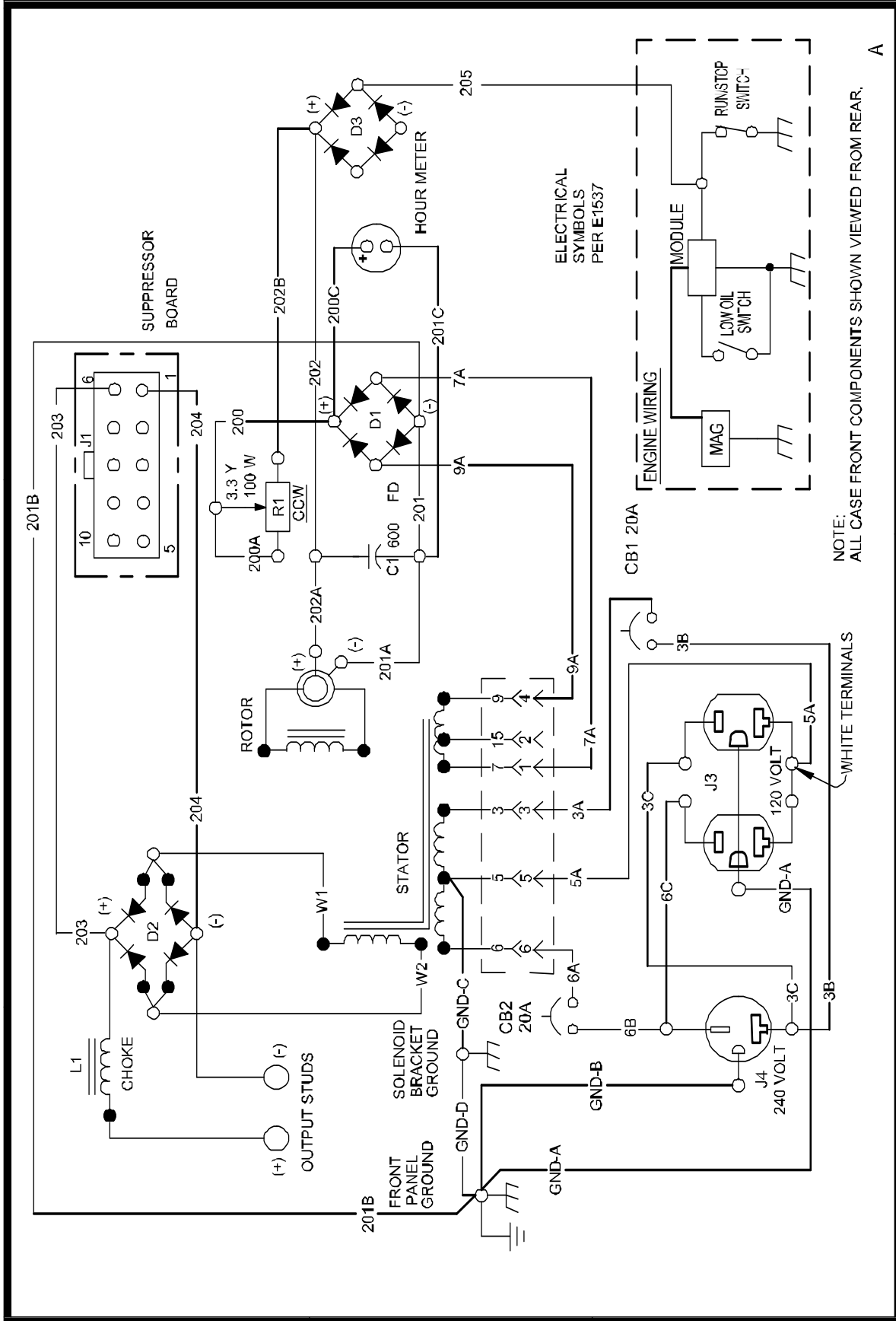

**S25985**

NOTE: This diagram is for reference only. It may not be accurate for all machines covered by this manual. The specific diagram for a particular code is pasted inside the machine on one of the enclosure panels. If the diagram is illegible, write to the Service Department for a replacement. Give the equipment code number..

# WIRING DIAGRAM

## WIRING DIAGRAM - WELDANPOWER 125 (FOR CODE 11406)

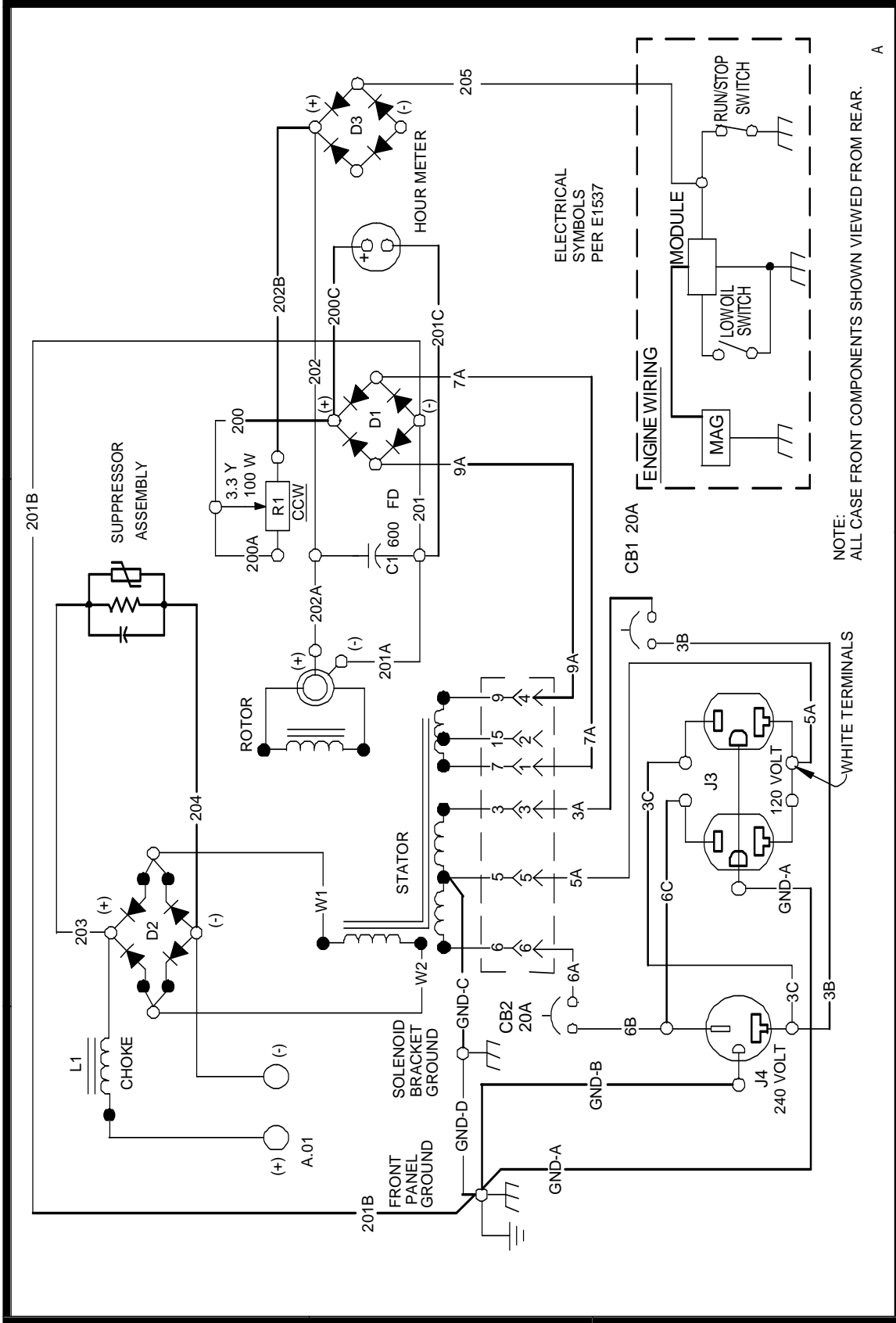

S26831

NOTE: This diagram is for reference only. It may not be accurate for all machines covered by this manual. The specific diagram for a particular code is pasted inside the machine on one of the enclosure panels. If the diagram is illegible, write to the Service Department for a replacement. Give the equipment code number..

# DIMENSION PRINT

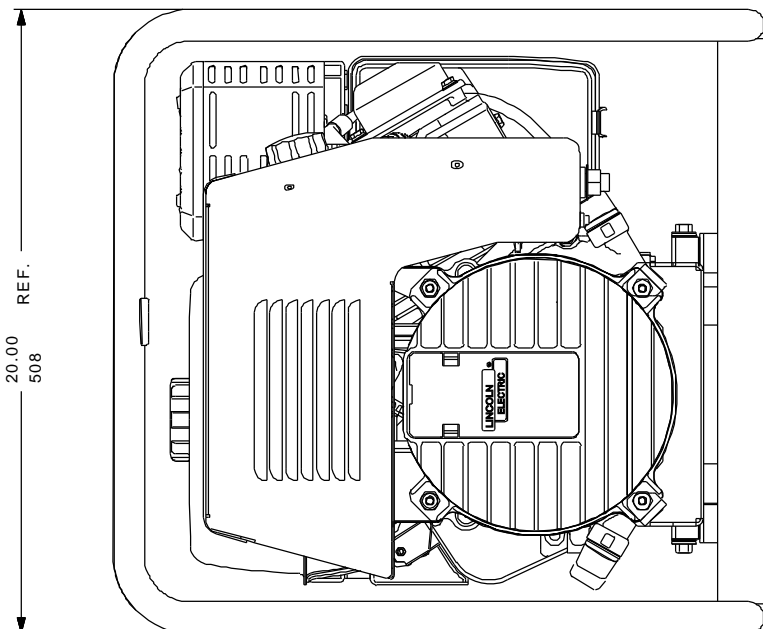
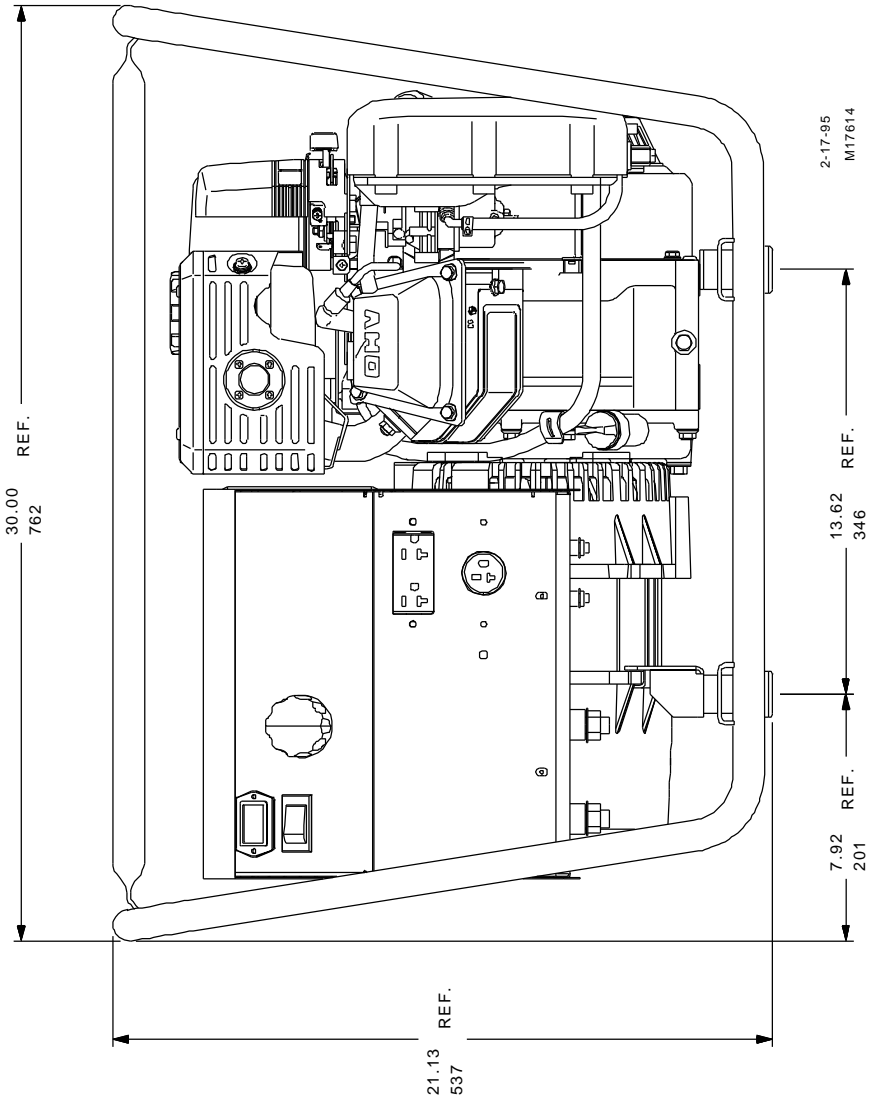

---

# NOTES

---

WELDPANPOWER 125



---

# NOTES

---

WELDANPOWER 125



<b>WARNING</b>	<ul style="list-style-type: none"> <li>● Do not touch electrically live parts or electrode with skin or wet clothing.</li> <li>● Insulate yourself from work and ground.</li> </ul>	<ul style="list-style-type: none"> <li>● Keep flammable materials away.</li> </ul>	<ul style="list-style-type: none"> <li>● Wear eye, ear and body protection.</li> </ul>
Spanish <b>AVISO DE PRECAUCION</b>	<ul style="list-style-type: none"> <li>● No toque las partes o los electrodos bajo carga con la piel o ropa mojada.</li> <li>● Aislese del trabajo y de la tierra.</li> </ul>	<ul style="list-style-type: none"> <li>● Mantenga el material combustible fuera del área de trabajo.</li> </ul>	<ul style="list-style-type: none"> <li>● Protéjase los ojos, los oídos y el cuerpo.</li> </ul>
French <b>ATTENTION</b>	<ul style="list-style-type: none"> <li>● Ne laissez ni la peau ni des vêtements mouillés entrer en contact avec des pièces sous tension.</li> <li>● Isolez-vous du travail et de la terre.</li> </ul>	<ul style="list-style-type: none"> <li>● Gardez à l'écart de tout matériel inflammable.</li> </ul>	<ul style="list-style-type: none"> <li>● Protégez vos yeux, vos oreilles et votre corps.</li> </ul>
German <b>WARNUNG</b>	<ul style="list-style-type: none"> <li>● Berühren Sie keine stromführenden Teile oder Elektroden mit Ihrem Körper oder feuchter Kleidung!</li> <li>● Isolieren Sie sich von den Elektroden und dem Erdboden!</li> </ul>	<ul style="list-style-type: none"> <li>● Entfernen Sie brennbares Material!</li> </ul>	<ul style="list-style-type: none"> <li>● Tragen Sie Augen-, Ohren- und Körperschutz!</li> </ul>
Portuguese <b>ATENÇÃO</b>	<ul style="list-style-type: none"> <li>● Não toque partes elétricas e electrodos com a pele ou roupa molhada.</li> <li>● Isole-se da peça e terra.</li> </ul>	<ul style="list-style-type: none"> <li>● Mantenha inflamáveis bem guardados.</li> </ul>	<ul style="list-style-type: none"> <li>● Use proteção para a vista, ouvido e corpo.</li> </ul>
Japanese <b>注意事項</b>	<ul style="list-style-type: none"> <li>● 通電中の電気部品、又は溶材にヒフやぬれた布で触れないこと。</li> <li>● 施工物やアースから身体が絶縁されている様にして下さい。</li> </ul>	<ul style="list-style-type: none"> <li>● 燃えやすいものの側での溶接作業は絶対にしてはなりません。</li> </ul>	<ul style="list-style-type: none"> <li>● 目、耳及び身体に保護具をして下さい。</li> </ul>
Chinese <b>警告</b>	<ul style="list-style-type: none"> <li>● 皮肤或湿衣物切勿接触带电部件及焊条。</li> <li>● 使你自已与地面和工作件绝缘。</li> </ul>	<ul style="list-style-type: none"> <li>● 把一切易燃物品移离工作场所。</li> </ul>	<ul style="list-style-type: none"> <li>● 佩戴眼、耳及身体劳动保护用具。</li> </ul>
Korean <b>위험</b>	<ul style="list-style-type: none"> <li>● 전도체나 용접봉을 젖은 형갑 또는 피부로 절대 접촉치 마십시오.</li> <li>● 모재와 접지를 접촉치 마십시오.</li> </ul>	<ul style="list-style-type: none"> <li>● 인화성 물질을 접근시키지 마십시오.</li> </ul>	<ul style="list-style-type: none"> <li>● 눈, 귀와 몸에 보호장구를 착용하십시오.</li> </ul>
Arabic <b>تحذير</b>	<ul style="list-style-type: none"> <li>● لا تلمس الاجزاء التي يسري فيها التيار الكهربائي أو الألكترود بجسد الجسم أو بالملابس المبللة بالماء.</li> <li>● ضع عازلا على جسمك خلال العمل.</li> </ul>	<ul style="list-style-type: none"> <li>● ضع المواد القابلة للاشتعال في مكان بعيد.</li> </ul>	<ul style="list-style-type: none"> <li>● ضع أدوات وملابس واقية على عينيك وأذنيك وجسمك.</li> </ul>

**READ AND UNDERSTAND THE MANUFACTURER'S INSTRUCTION FOR THIS EQUIPMENT AND THE CONSUMABLES TO BE USED AND FOLLOW YOUR EMPLOYER'S SAFETY PRACTICES.**

**SE RECOMIENDA LEER Y ENTENDER LAS INSTRUCCIONES DEL FABRICANTE PARA EL USO DE ESTE EQUIPO Y LOS CONSUMIBLES QUE VA A UTILIZAR, SIGA LAS MEDIDAS DE SEGURIDAD DE SU SUPERVISOR.**

**LISEZ ET COMPRENEZ LES INSTRUCTIONS DU FABRICANT EN CE QUI REGARDE CET EQUIPMENT ET LES PRODUITS A ETRE EMPLOYES ET SUIVEZ LES PROCEDURES DE SECURITE DE VOTRE EMPLOYEUR.**

**LESEN SIE UND BEFOLGEN SIE DIE BETRIEBSANLEITUNG DER ANLAGE UND DEN ELEKTRODENEINSATZ DES HERSTELLERS. DIE UNFALLVERHÜTUNGSVORSCHRIFTEN DES ARBEITGEBERS SIND EBENFALLS ZU BEACHTEN.**

			
<ul style="list-style-type: none"> <li>● Keep your head out of fumes.</li> <li>● Use ventilation or exhaust to remove fumes from breathing zone.</li> </ul>	<ul style="list-style-type: none"> <li>● Turn power off before servicing.</li> </ul>	<ul style="list-style-type: none"> <li>● Do not operate with panel open or guards off.</li> </ul>	<b>WARNING</b>
<ul style="list-style-type: none"> <li>● Los humos fuera de la zona de respiración.</li> <li>● Mantenga la cabeza fuera de los humos. Utilice ventilación o aspiración para gases.</li> </ul>	<ul style="list-style-type: none"> <li>● Desconectar el cable de alimentación de poder de la máquina antes de iniciar cualquier servicio.</li> </ul>	<ul style="list-style-type: none"> <li>● No operar con panel abierto o guardas quitadas.</li> </ul>	Spanish <b>AVISO DE PRECAUCION</b>
<ul style="list-style-type: none"> <li>● Gardez la tête à l'écart des fumées.</li> <li>● Utilisez un ventilateur ou un aspirateur pour ôter les fumées des zones de travail.</li> </ul>	<ul style="list-style-type: none"> <li>● Débranchez le courant avant l'entretien.</li> </ul>	<ul style="list-style-type: none"> <li>● N'opérez pas avec les panneaux ouverts ou avec les dispositifs de protection enlevés.</li> </ul>	French <b>ATTENTION</b>
<ul style="list-style-type: none"> <li>● Vermeiden Sie das Einatmen von Schweißrauch!</li> <li>● Sorgen Sie für gute Be- und Entlüftung des Arbeitsplatzes!</li> </ul>	<ul style="list-style-type: none"> <li>● Strom vor Wartungsarbeiten abschalten! (Netzstrom völlig öffnen; Maschine anhalten!)</li> </ul>	<ul style="list-style-type: none"> <li>● Anlage nie ohne Schutzgehäuse oder Innenschutzverkleidung in Betrieb setzen!</li> </ul>	German <b>WARNUNG</b>
<ul style="list-style-type: none"> <li>● Mantenha seu rosto da fumaça.</li> <li>● Use ventilação e exaustão para remover fumo da zona respiratória.</li> </ul>	<ul style="list-style-type: none"> <li>● Não opere com as tampas removidas.</li> <li>● Desligue a corrente antes de fazer serviço.</li> <li>● Não toque as partes elétricas nuas.</li> </ul>	<ul style="list-style-type: none"> <li>● Mantenha-se afastado das partes moventes.</li> <li>● Não opere com os painéis abertos ou guardas removidas.</li> </ul>	Portuguese <b>ATENÇÃO</b>
<ul style="list-style-type: none"> <li>● ヒュームから頭を離すようにして下さい。</li> <li>● 換気や排煙に十分留意して下さい。</li> </ul>	<ul style="list-style-type: none"> <li>● メンテナンス・サービスに取りかかる際には、まず電源スイッチを必ず切して下さい。</li> </ul>	<ul style="list-style-type: none"> <li>● パネルやカバーを取り外したまま機械操作をしないで下さい。</li> </ul>	Japanese <b>注意事項</b>
<ul style="list-style-type: none"> <li>● 頭部遠離煙霧。</li> <li>● 在呼吸區使用通風或排風器除煙。</li> </ul>	<ul style="list-style-type: none"> <li>● 維修前切斷電源。</li> </ul>	<ul style="list-style-type: none"> <li>● 儀表板打開或沒有安全罩時不準作業。</li> </ul>	Chinese <b>警告</b>
<ul style="list-style-type: none"> <li>● 얼굴로부터 용접가스를 멀리하십시오.</li> <li>● 호흡지역으로부터 용접가스를 제거하기 위해 가스제거기나 통풍기를 사용하십시오.</li> </ul>	<ul style="list-style-type: none"> <li>● 보수전에 전원을 차단하십시오.</li> </ul>	<ul style="list-style-type: none"> <li>● 판넬이 열린 상태로 작동치 마십시오.</li> </ul>	Korean <b>위험</b>
<ul style="list-style-type: none"> <li>● ابعء رأسك بعيداً عن الدخان.</li> <li>● استعمل التهوية أو جهاز ضغط الدخان للخارج لكي تبعد الدخان عن المنطقة التي تتنفس فيها.</li> </ul>	<ul style="list-style-type: none"> <li>● أقطع التيار الكهربائي قبل القيام بأية صيانة.</li> </ul>	<ul style="list-style-type: none"> <li>● لا تشغيل هذا الجهاز اذا كانت الاغطية الحديدية الواقية ليست عليه.</li> </ul>	Arabic <b>تحذير</b>

**LEIA E COMPREENDA AS INSTRUÇÕES DO FABRICANTE PARA ESTE EQUIPAMENTO E AS PARTES DE USO, E SIGA AS PRÁTICAS DE SEGURANÇA DO EMPREGADOR.**

使う機械や溶材のメーカーの指示書をよく読み、まず理解して下さい。そして貴社の安全規定に従って下さい。

請詳細閱讀並理解製造廠提供的說明以及應該使用的銀焊材料，並請遵守貴方的有閣勞動保護規定。

이 제품에 동봉된 작업지침서를 숙지하시고 귀사의 작업자 안전수칙을 준수하시기 바랍니다.

اقرأ بتمعن وافهم تعليمات المصنع المنتج لهذه المعدات والمواد قبل استعمالها واتبع تعليمات الوقاية لصاحب العمل.



• World's Leader in Welding and Cutting Products •

• Sales and Service through Subsidiaries and Distributors Worldwide •

Cleveland, Ohio 44117-1199 U.S.A. TEL: 216.481.8100 FAX: 216.486.1751 WEB SITE: [www.lincolnelectric.com](http://www.lincolnelectric.com)