



NOTE: This manual will cover most of the troubleshooting and repair procedures for the code numbers listed. Some variances may exist when troubleshooting/repairing later code numbers.

MULTI-WELD® 350 ARC CONVERTER

For use with machines having Code Numbers:

10645

10736

11148

11854

SERVICE MANUAL

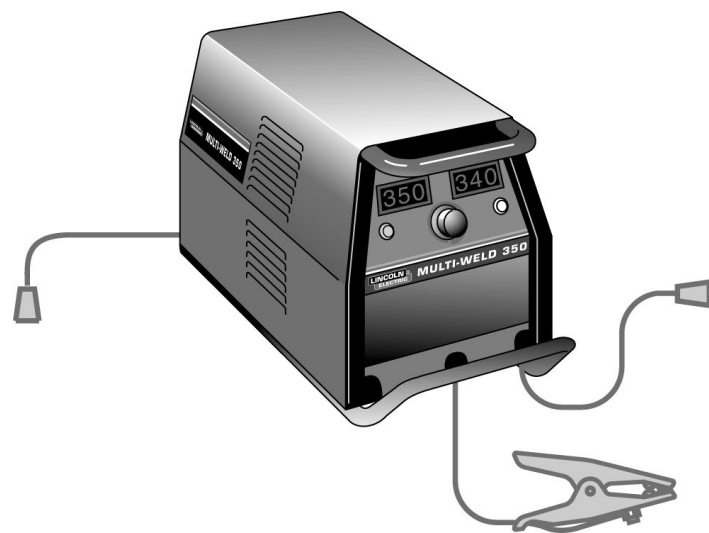

⚠ WARNING

⚠ CALIFORNIA PROPOSITION 65 WARNINGS ⚠

Diesel engine exhaust and some of its constituents are known to the State of California to cause cancer, birth defects, and other reproductive harm.

The Above For Diesel Engines

The engine exhaust from this product contains chemicals known to the State of California to cause cancer, birth defects, or other reproductive harm.

The Above For Gasoline Engines

ARC WELDING can be hazardous. PROTECT YOURSELF AND OTHERS FROM POSSIBLE SERIOUS INJURY OR DEATH. KEEP CHILDREN AWAY. PACEMAKER WEARERS SHOULD CONSULT WITH THEIR DOCTOR BEFORE OPERATING.

Read and understand the following safety highlights. For additional safety information, it is strongly recommended that you purchase a copy of "Safety in Welding & Cutting - ANSI Standard Z49.1" from the American Welding Society, P.O. Box 351040, Miami, Florida 33135 or CSA Standard W117.2-1974. A Free copy of "Arc Welding Safety" booklet E205 is available from the Lincoln Electric Company, 22801 St. Clair Avenue, Cleveland, Ohio 44117-1199.

BE SURE THAT ALL INSTALLATION, OPERATION, MAINTENANCE AND REPAIR PROCEDURES ARE PERFORMED ONLY BY QUALIFIED INDIVIDUALS.



FOR ENGINE powered equipment.

1.a. Turn the engine off before troubleshooting and maintenance work unless the maintenance work requires it to be running.



1.b. Operate engines in open, well-ventilated areas or vent the engine exhaust fumes outdoors.



1.c. Do not add the fuel near an open flame welding arc or when the engine is running. Stop the engine and allow it to cool before refueling to prevent spilled fuel from vaporizing on contact with hot engine parts and igniting. Do not spill fuel when filling tank. If fuel is spilled, wipe it up and do not start engine until fumes have been eliminated.

1.d. Keep all equipment safety guards, covers and devices in position and in good repair. Keep hands, hair, clothing and tools away from V-belts, gears, fans and all other moving parts when starting, operating or repairing equipment.

1.e. In some cases it may be necessary to remove safety guards to perform required maintenance. Remove guards only when necessary and replace them when the maintenance requiring their removal is complete. Always use the greatest care when working near moving parts.



1.f. Do not put your hands near the engine fan. Do not attempt to override the governor or idler by pushing on the throttle control rods while the engine is running.

1.g. To prevent accidentally starting gasoline engines while turning the engine or welding generator during maintenance work, disconnect the spark plug wires, distributor cap or magneto wire as appropriate.



1.h. To avoid scalding, do not remove the radiator pressure cap when the engine is hot.



ELECTRIC AND MAGNETIC FIELDS may be dangerous

2.a. Electric current flowing through any conductor causes localized Electric and Magnetic Fields (EMF). Welding current creates EMF fields around welding cables and welding machines

2.b. EMF fields may interfere with some pacemakers, and welders having a pacemaker should consult their physician before welding.

2.c. Exposure to EMF fields in welding may have other health effects which are now not known.

2.d. All welders should use the following procedures in order to minimize exposure to EMF fields from the welding circuit:

2.d.1. Route the electrode and work cables together - Secure them with tape when possible.

2.d.2. Never coil the electrode lead around your body.

2.d.3. Do not place your body between the electrode and work cables. If the electrode cable is on your right side, the work cable should also be on your right side.

2.d.4. Connect the work cable to the workpiece as close as possible to the area being welded.

2.d.5. Do not work next to welding power source.



ELECTRIC SHOCK can kill.

3.a. The electrode and work (or ground) circuits are electrically “hot” when the welder is on. Do not touch these “hot” parts with your bare skin or wet clothing. Wear dry, hole-free gloves to insulate hands.

3.b. Insulate yourself from work and ground using dry insulation. Make certain the insulation is large enough to cover your full area of physical contact with work and ground.

In addition to the normal safety precautions, if welding must be performed under electrically hazardous conditions (in damp locations or while wearing wet clothing; on metal structures such as floors, gratings or scaffolds; when in cramped positions such as sitting, kneeling or lying, if there is a high risk of unavoidable or accidental contact with the workpiece or ground) use the following equipment:

- Semiautomatic DC Constant Voltage (Wire) Welder.
- DC Manual (Stick) Welder.
- AC Welder with Reduced Voltage Control.

3.c. In semiautomatic or automatic wire welding, the electrode, electrode reel, welding head, nozzle or semiautomatic welding gun are also electrically “hot”.

3.d. Always be sure the work cable makes a good electrical connection with the metal being welded. The connection should be as close as possible to the area being welded.

3.e. Ground the work or metal to be welded to a good electrical (earth) ground.

3.f. Maintain the electrode holder, work clamp, welding cable and welding machine in good, safe operating condition. Replace damaged insulation.

3.g. Never dip the electrode in water for cooling.

3.h. Never simultaneously touch electrically “hot” parts of electrode holders connected to two welders because voltage between the two can be the total of the open circuit voltage of both welders.

3.i. When working above floor level, use a safety belt to protect yourself from a fall should you get a shock.

3.j. Also see Items 6.c. and 8.



ARC RAYS can burn.

4.a. Use a shield with the proper filter and cover plates to protect your eyes from sparks and the rays of the arc when welding or observing open arc welding. Headshield and filter lens should conform to ANSI Z87.1 standards.

4.b. Use suitable clothing made from durable flame-resistant material to protect your skin and that of your helpers from the arc rays.

4.c. Protect other nearby personnel with suitable, non-flammable screening and/or warn them not to watch the arc nor expose themselves to the arc rays or to hot spatter or metal.



FUMES AND GASES can be dangerous.

5.a. Welding may produce fumes and gases hazardous to health. Avoid breathing these fumes and gases. When welding, keep your head out of the fume. Use enough ventilation and/or exhaust at the arc to keep fumes and gases away from the breathing zone. **When welding with electrodes which require special ventilation such as stainless or hard facing (see instructions on container or MSDS) or on lead or cadmium plated steel and other metals or coatings which produce highly toxic fumes, keep exposure as low as possible and within applicable OSHA PEL and ACGIH TLV limits using local exhaust or mechanical ventilation. In confined spaces or in some circumstances, outdoors, a respirator may be required. Additional precautions are also required when welding on galvanized steel.**

5.b. The operation of welding fume control equipment is affected by various factors including proper use and positioning of the equipment, maintenance of the equipment and the specific welding procedure and application involved. Worker exposure level should be checked upon installation and periodically thereafter to be certain it is within applicable OSHA PEL and ACGIH TLV limits.

5.c. Do not weld in locations near chlorinated hydrocarbon vapors coming from degreasing, cleaning or spraying operations. The heat and rays of the arc can react with solvent vapors to form phosgene, a highly toxic gas, and other irritating products.

5.d. Shielding gases used for arc welding can displace air and cause injury or death. Always use enough ventilation, especially in confined areas, to insure breathing air is safe.

5.e. Read and understand the manufacturer's instructions for this equipment and the consumables to be used, including the material safety data sheet (MSDS) and follow your employer's safety practices. MSDS forms are available from your welding distributor or from the manufacturer.

5.f. Also see item 1.b.

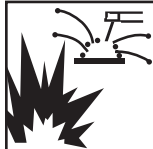

WELDING and CUTTING SPARKS can cause fire or explosion.

6.a. Remove fire hazards from the welding area. If this is not possible, cover them to prevent the welding sparks from starting a fire. Remember that welding sparks and hot materials from welding can easily go through small cracks and openings to adjacent areas. Avoid welding near hydraulic lines. Have a fire extinguisher readily available.

- 6.b. Where compressed gases are to be used at the job site, special precautions should be used to prevent hazardous situations. Refer to "Safety in Welding and Cutting" (ANSI Standard Z49.1) and the operating information for the equipment being used.
- 6.c. When not welding, make certain no part of the electrode circuit is touching the work or ground. Accidental contact can cause overheating and create a fire hazard.
- 6.d. Do not heat, cut or weld tanks, drums or containers until the proper steps have been taken to insure that such procedures will not cause flammable or toxic vapors from substances inside. They can cause an explosion even though they have been "cleaned". For information, purchase "Recommended Safe Practices for the Preparation for Welding and Cutting of Containers and Piping That Have Held Hazardous Substances", AWS F4.1 from the American Welding Society (see address above).
- 6.e. Vent hollow castings or containers before heating, cutting or welding. They may explode.
- 6.f. Sparks and spatter are thrown from the welding arc. Wear oil free protective garments such as leather gloves, heavy shirt, cuffless trousers, high shoes and a cap over your hair. Wear ear plugs when welding out of position or in confined places. Always wear safety glasses with side shields when in a welding area.
- 6.g. Connect the work cable to the work as close to the welding area as practical. Work cables connected to the building framework or other locations away from the welding area increase the possibility of the welding current passing through lifting chains, crane cables or other alternate circuits. This can create fire hazards or overheat lifting chains or cables until they fail.
- 6.h. Also see item 1.c.
- 6.i. Read and follow NFPA 51B "Standard for Fire Prevention During Welding, Cutting and Other Hot Work", available from NFPA, 1 Batterymarch Park, PO box 9101, Quincy, Ma 022690-9101.
- 6.j. Do not use a welding power source for pipe thawing.



CYLINDER may explode if damaged.

- 7.a. Use only compressed gas cylinders containing the correct shielding gas for the process used and properly operating regulators designed for the gas and pressure used. All hoses, fittings, etc. should be suitable for the application and maintained in good condition.
- 7.b. Always keep cylinders in an upright position securely chained to an undercarriage or fixed support.
- 7.c. Cylinders should be located:
 - Away from areas where they may be struck or subjected to physical damage.
 - A safe distance from arc welding or cutting operations and any other source of heat, sparks, or flame.
- 7.d. Never allow the electrode, electrode holder or any other electrically "hot" parts to touch a cylinder.
- 7.e. Keep your head and face away from the cylinder valve outlet when opening the cylinder valve.
- 7.f. Valve protection caps should always be in place and hand tight except when the cylinder is in use or connected for use.
- 7.g. Read and follow the instructions on compressed gas cylinders, associated equipment, and CGA publication P-1, "Precautions for Safe Handling of Compressed Gases in Cylinders," available from the Compressed Gas Association 1235 Jefferson Davis Highway, Arlington, VA 22202.



FOR ELECTRICALLY powered equipment.

- 8.a. Turn off input power using the disconnect switch at the fuse box before working on the equipment.
- 8.b. Install equipment in accordance with the U.S. National Electrical Code, all local codes and the manufacturer's recommendations.
- 8.c. Ground the equipment in accordance with the U.S. National Electrical Code and the manufacturer's recommendations.

Refer to <http://www.lincolnelectric.com/safety> for additional safety information.

PRÉCAUTIONS DE SÛRETÉ

Pour votre propre protection lire et observer toutes les instructions et les précautions de sûreté spécifiques qui paraissent dans ce manuel aussi bien que les précautions de sûreté générales suivantes:

Sûreté Pour Soudage A L'Arc

1. Protégez-vous contre la secousse électrique:
 - a. Les circuits à l'électrode et à la pièce sont sous tension quand la machine à souder est en marche. Eviter toujours tout contact entre les parties sous tension et la peau nue ou les vêtements mouillés. Porter des gants secs et sans trous pour isoler les mains.
 - b. Faire très attention de bien s'isoler de la masse quand on soude dans des endroits humides, ou sur un plancher métallique ou des grilles métalliques, principalement dans les positions assis ou couché pour lesquelles une grande partie du corps peut être en contact avec la masse.
 - c. Maintenir le porte-électrode, la pince de masse, le câble de soudage et la machine à souder en bon et sûr état de fonctionnement.
 - d. Ne jamais plonger le porte-électrode dans l'eau pour le refroidir.
 - e. Ne jamais toucher simultanément les parties sous tension des porte-électrodes connectés à deux machines à souder parce que la tension entre les deux pinces peut être le total de la tension à vide des deux machines.
 - f. Si on utilise la machine à souder comme une source de courant pour soudage semi-automatique, ces précautions pour le porte-électrode s'appliquent aussi au pistolet de soudage.
2. Dans le cas de travail au dessus du niveau du sol, se protéger contre les chutes dans le cas où on reçoit un choc. Ne jamais enrouler le câble-électrode autour de n'importe quelle partie du corps.
3. Un coup d'arc peut être plus sévère qu'un coup de soliel, donc:
 - a. Utiliser un bon masque avec un verre filtrant approprié ainsi qu'un verre blanc afin de se protéger les yeux du rayonnement de l'arc et des projections quand on soude ou quand on regarde l'arc.
 - b. Porter des vêtements convenables afin de protéger la peau de soudeur et des aides contre le rayonnement de l'arc.
 - c. Protéger l'autre personnel travaillant à proximité au soudage à l'aide d'écrans appropriés et non-inflammables.
4. Des gouttes de laitier en fusion sont émises de l'arc de soudage. Se protéger avec des vêtements de protection libres de l'huile, tels que les gants en cuir, chemise épaisse, pantalons sans revers, et chaussures montantes.
5. Toujours porter des lunettes de sécurité dans la zone de soudage. Utiliser des lunettes avec écrans latéraux dans les zones où l'on pique le laitier.

6. Eloigner les matériaux inflammables ou les recouvrir afin de prévenir tout risque d'incendie dû aux étincelles.
7. Quand on ne soude pas, poser la pince à un endroit isolé de la masse. Un court-circuit accidentel peut provoquer un échauffement et un risque d'incendie.
8. S'assurer que la masse est connectée le plus près possible de la zone de travail qu'il est pratique de le faire. Si on place la masse sur la charpente de la construction ou d'autres endroits éloignés de la zone de travail, on augmente le risque de voir passer le courant de soudage par les chaînes de levage, câbles de grue, ou autres circuits. Cela peut provoquer des risques d'incendie ou d'échauffement des chaînes et des câbles jusqu'à ce qu'ils se rompent.
9. Assurer une ventilation suffisante dans la zone de soudage. Ceci est particulièrement important pour le soudage de tôles galvanisées plombées, ou cadmiées ou tout autre métal qui produit des fumées toxiques.
10. Ne pas souder en présence de vapeurs de chlore provenant d'opérations de dégraissage, nettoyage ou pistolage. La chaleur ou les rayons de l'arc peuvent réagir avec les vapeurs du solvant pour produire du phosgène (gas fortement toxique) ou autres produits irritants.
11. Pour obtenir de plus amples renseignements sur la sûreté, voir le code "Code for safety in welding and cutting" CSA Standard W 117.2-1974.

PRÉCAUTIONS DE SÛRETÉ POUR LES MACHINES À SOUDER À TRANSFORMATEUR ET À REDRESSEUR

1. Relier à la terre le châssis du poste conformément au code de l'électricité et aux recommandations du fabricant. Le dispositif de montage ou la pièce à souder doit être branché à une bonne mise à la terre.
2. Autant que possible, l'installation et l'entretien du poste seront effectués par un électricien qualifié.
3. Avant de faire des travaux à l'intérieur de poste, la débrancher à l'interrupteur à la boîte de fusibles.
4. Garder tous les couvercles et dispositifs de sûreté à leur place.

	Page
Safety	i-iv
Installation.....	Section A
Operation.....	Section B
Accessories	Section C
Maintenance.....	Section D
Theory of Operation	Section E
Troubleshooting and Repair	Section F
Electrical Diagrams	Section G
Parts Manual.....	P361 Series

TABLE OF CONTENTS - INSTALLATION SECTION -

InstallationA-1

 Technical SpecificationsA-2

 Safety PrecautionsA-3

 Quick-Connect “Pig-Tails”A-3

 Attachment and Arrangement of “Pig-Tails”A-3

 Work ConnectionA-4

 Case GroundingA-4

 Inter-Connection of ConvertersA-4

 Power Source SetupA-6

Return to Master TOC

Return to Master TOC

Return to Master TOC

Return to Master TOC

INSTALLATION

TECHNICAL SPECIFICATIONS - MULTI-WELD® 350 (K1735-1)

ELECTRICAL SPECIFICATIONS

	<u>Amps (DC+)</u>	<u>Volts (DC+)</u>
Output Rating @ 50°C (122°F)	350	34
Input Rating @ 50°C (122°F)	165	80
Max. Input Range		50-113 (Peak)
Max. O.C.V.		78
Output Preset Range	30-350	15-40

PHYSICAL DIMENSIONS

<u>Height</u>	<u>Width</u>	<u>Depth</u>	<u>Net Weight</u>
11.6 in. 295 mm	10.0 in. 254 mm	21.5 in. 546 mm	59.5 lbs. 27.0 kg.

TEMPERATURE RANGES

<u>Operating Temperature Range</u>	<u>Storage Temperature Range</u>
-40 to +122°F -20 to +50°C	-40 to +185°F -40 to +85°C

MULTI-WELD® 350



Read this entire installation section before you start installation.

SAFETY PRECAUTIONS

WARNING

ELECTRIC SHOCK can kill.



- Do not touch electrically live parts or electrodes with your skin or wet clothing.
- Insulate yourself from the work and ground.
- Always wear dry insulating gloves.

Only qualified personnel should install, use, or service this equipment.

QUICK-CONNECT “PIG-TAILS”

The MULTI-WELD® 350 is factory provided with two 21 in. (53 cm) long 2/0 AWG (70 mm²) “pig-tail” cables. Their 0.5” (13 mm) hole lug ends are routed through the “INPUT +” (on back) and “ELECTRODE +” (on front) cable channels of the Converter. They are attached to the bottom-accessed covered cable connection studs.

Attach the preferred standard, user-provided Quick-connect terminal (such as Lincoln Twist-Mate or Tweco 2-MPC type) to the cut-off end of these cables. Use the female connector on the “ELECTRODE +” cable and the male connector on the “INPUT +” cable.

ATTACHMENT AND ARRANGEMENT OF “PIG-TAILS”

To best suit the desired inter-connection of the Converters, the “pig-tail” cables may be routed into the front or back cable channels. For single or double “pig-tail” cables, route through the bottom-accessed covered cable connection studs. (See Figures A.1 and B.1.)

FIGURE A.1 – PIG-TAIL CONNECTIONS

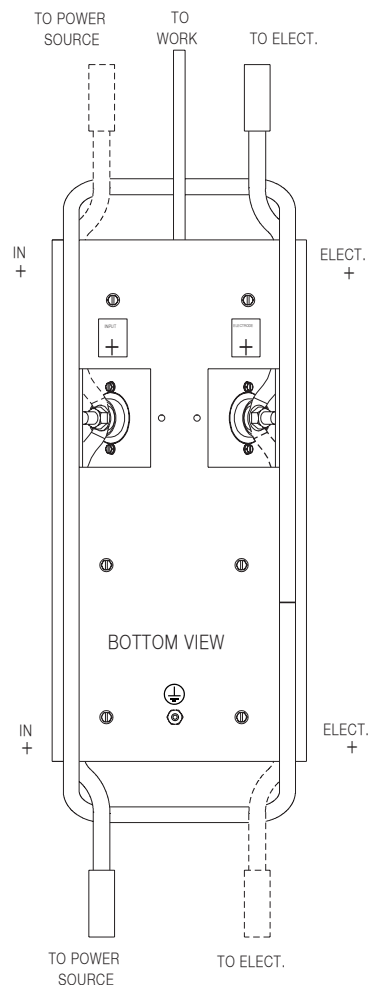

To connect the “pig-tail” cables to the Converter:

1. Stand the Converter vertically on its rear handle and skid to gain access to the bottom stud covers. Then remove the two 0.25” (6.3 mm) screws securing each cover and fold out the cover insulation.
2. Route the appropriate “pig-tail” cable lug ends under the skid rail (for strain-relief) through the desired front and/or rear corner channels to the exposed 0.5” (13 mm) stud. Remove the flange nut with a .75” (19 mm) wrench.

NOTE: Input supply cable(s) must connect through “INPUT +” labeled channels, and output weld cable(s) must connect through “ELECTRODE +” labeled channels.

3. Slip the “pig-tail” cable lug(s) over the stud and re-secure the flange nut. Make sure that the lug(s) do not touch any sheet metal of the stud housing. Fold back the cover insulation and replace the stud cover.

MULTI-WELD® 350



INSTALLATION

⚠ WARNING



Be sure to follow the safety practice to use the female connector on the cable which would normally be electrically "hot" (supply lead) if disconnected when the system is energized, and the male on the normally "cold" (load lead) side. If practical, shut off power before connecting or disconnecting terminals.

WORK CONNECTION

Each Converter in the Multi-Weld system must have its individual "Work" lead connected (clipped) to the work. The #3 AWG (27 mm²) Work clip lead must have clean metal connection to the work to complete the DC input supply and output power circuits of the MULTI-WELD[®] 350.

⚠ WARNING

Do not disconnect the Work clip lead without first switching OFF the Converter panel switch. Failure to do so will allow the Work lead clip to be electrically "hot" to work and "hot" to the electrode, through the circuit of the Converter, for about 5 seconds until the input contactor opens.

CASE GROUNDING

As shipped, the case of the MULTI-WELD[®] 350 is isolated from all of the DC input and output welding terminals. It is equipped with a grounding terminal screw (.31" / 7.9 mm) marked with the symbol \oplus located on the bottom rear of the base assembly. (Refer to the bottom view figure.) In order to comply with CSA and UL case grounding specifications, this terminal is provided for connection to weldment work that must be properly grounded per methods meeting local and national electrical codes. Refer to "Safety in Welding, Cutting and Allied Processes," ANSI Z49.1 (US) and W117.2 (Canada).

Since any case fault would only involve the DC welding circuit, the size of the grounding lead should have the capacity to ground the potential fault current without burning open. Use at least #6 AWG (13 mm²), but need not exceed the size of the input cable supplying the MULTI-WELD[®] 350.

Connect the Multi-Weld grounding lead to the work piece separately from the Work clip. If the same clip is used for both ground and work connection, the Multi-Weld case will be electrically "hot" to the work if the clip is removed without first switching OFF the panel switch. (Refer to the Work clip WARNING).

INTER-CONNECTION OF CONVERTERS

The input and electrode cables of the MULTI-WELD[®] 350 Converters may be inter-connected in a Multi-Weld system using any combination of Distribution Box(es) (See **Figure B.1**), paralleling (CC mode only) and "daisy-chaining" (See **Figure A.2**). Choose the configuration that best fits the field application setup within the capacity of the power source supplying the system.

Power Source (Volts x Amp) capacity > 1.1 x
Sum of Converters' (Volts x Amps) arcs

⚠ WARNING

Paralleled units may be powered from more than one source. Disconnect all inputs, including outputs from other sources, before working on the equipment. Before removing the parallel jumper, be sure both Converters are switched OFF. If not, the male side of the first disconnection will be electrically "hot" to work.

MULTI-WELD[®] 350



INSTALLATION

FIGURE A.2 – INTER-CONNECTING CONVERTERS

FIXED PARALLEL OPERATION

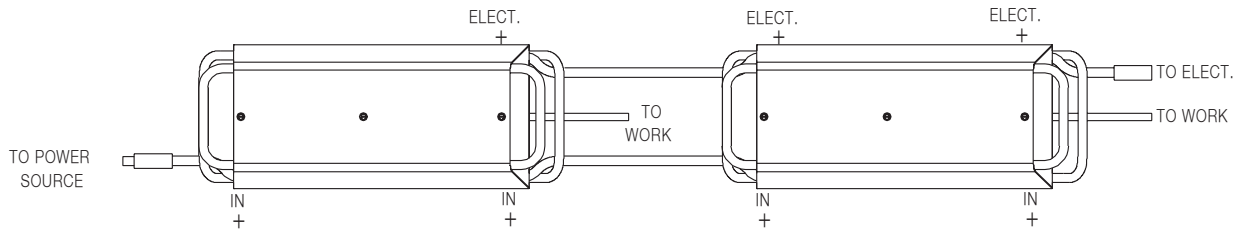

DAISY CHAIN OPERATION

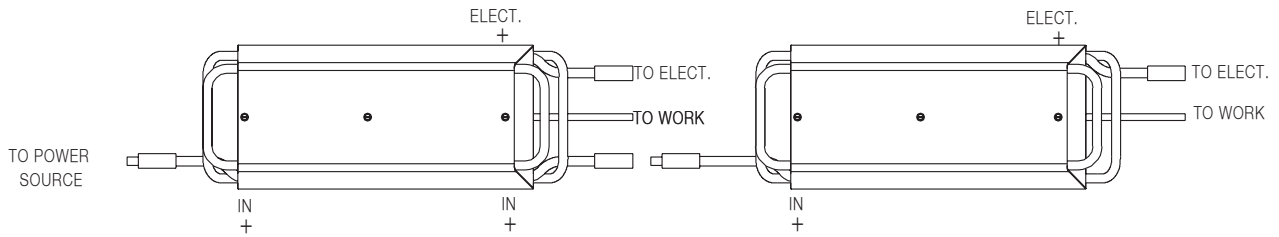

SEPARABLE PARALLEL OPERATION

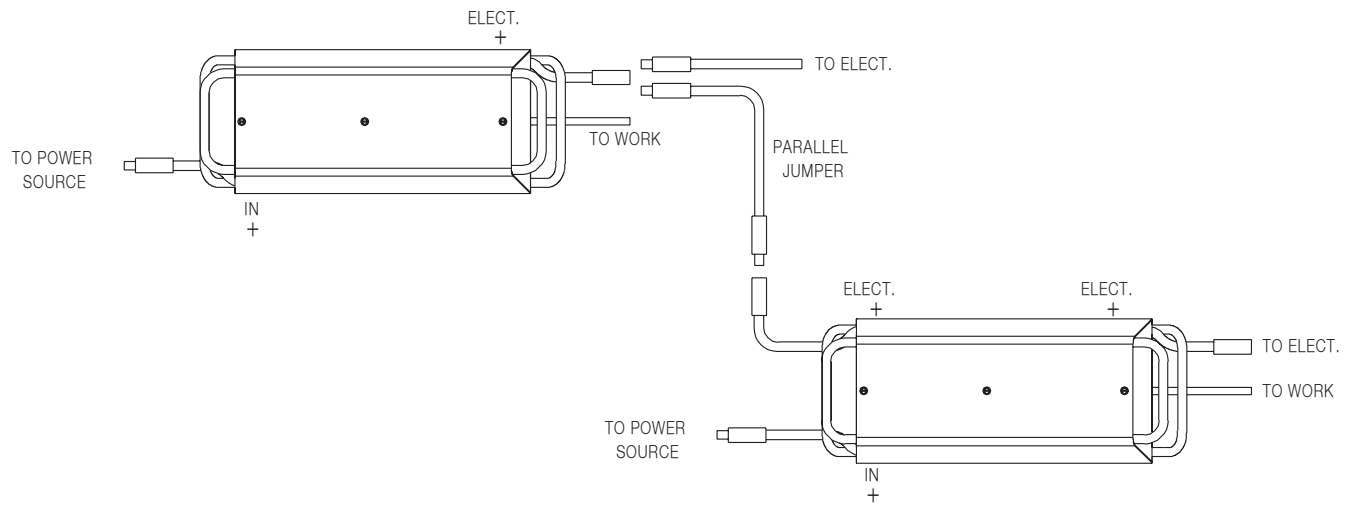

MULTI-WELD® 350



Return to Section TOC
 Return to Section TOC
 Return to Section TOC
 Return to Section TOC
 Return to Master TOC
 Return to Master TOC
 Return to Master TOC
 Return to Master TOC

INSTALLATION

For Converters (operating at rated output) less than 200 ft. (61 m) from the power source, the following minimum cable sizes are recommended for the indicated quantity of Converters supplied by the input cable run to keep cable temperature and voltage drop within acceptable limits:

Converters on Cable	Cable Size AWG (mm ²)
1	1/0 (50)
2	2/0 (70)
3	3/0 (95)
4	4/0 (120)
5	2x3/0 (2x95)

The output "Electrode" cable should be 2/0 AWG (70 mm²) if sized for rated output up to 200 ft.(61 m) from the Converter. If paralleled, the output cable to the arc should be 4/0 (120 mm²).

WARNING

Do not disconnect the Work clip lead without first switching OFF the Converter panel switch. Failure to do so will allow the Work lead clip to be electrically "hot" to work and "hot" to the electrode, through the circuit of the Converter, for about 5 seconds until the input contactor opens.

POWER SOURCE SETUP

Refer to the Instruction Manual provided with the Multi-Source power source, or other DC power source being used, for input power supply connections, output connections and controls setup.

In general:

1. Connect the positive (+) output connection terminal to the input supplying the Multi-Weld system and the negative (-) output connection terminal to the work. (See **Figure A.1.**)
2. If not using a Multi-Source power source:
 - a. If an inductance control, or tap, is selectable, use lowest inductance.
 - b. Use CC (Constant Current) mode for maximum supply voltage.
 - c. Set panel output control to maximum for maximum current capacity.
 - d. Activate output with the "output terminals on" switch, or jumper (2-4 on Lincoln Electric terminal strips).

TABLE OF CONTENTS - OPERATION SECTION -

Operation	Section B
Safety Instructions.....	B-2
Product Description.....	B-3
Recommended Equipment and Processes.....	B-4
Multi-System Power Source.....	B-4
Distribution Box.....	B-4
"Pig-Tail" Leads and Connectors	B-4
Remote Output Control Options	B-5
CV Mode Wire Welding.....	B-5
CC Mode Stick Welding and Gouging	B-5
Front Panel Controls	B-6
Recessed Panel Controls.....	B-7
Paralleled Converters.....	B-8
Remote Control of Paralleled Converters	B-8
Transporting and Storage of the MULTI-WELD® 350	B-8
Cable Handling	B-8
Transporting	B-9
Storage	B-9
Protection Features	B-9
Fan as Needed (F.A.N.).....	B-9
Over-Voltage Protection.....	B-9
Over-Current Protection.....	B-9
Over-Temperature Shutdown.....	B-9

Return to Master TOC

Return to Master TOC

Return to Master TOC

Return to Master TOC

OPERATION

OPERATING INSTRUCTIONS

Read and understand this entire section of operating instructions before operating the machine.

SAFETY INSTRUCTIONS



WARNING

ELECTRIC SHOCK can kill.



- Do not touch electrically live parts or electrodes with your skin or wet clothing.
- Insulate yourself from the work and ground.
- Always wear dry insulating gloves.



FUMES AND GASES CAN BE DANGEROUS.

- Keep your head out of fumes.
- Use ventilation or exhaust to remove fumes from breathing zone.



WELDING SPARKS CAN CAUSE FIRE OR EXPLOSION.

- Keep flammable material away.
- Do not weld on containers that have held combustibles.



ARC RAYS CAN BURN.

- Wear eye, ear, and body protection.

Observe additional Safety Guidelines detailed in the beginning of this manual.

MULTI-WELD® 350



PRODUCT DESCRIPTION

The MULTI-WELD® 350 Arc Converter (K1735-1) is part of a Multi-Weld system, ideally suited for construction site welding. It uses a single DC power source as the only input supply and provides independent, full-range control of up to 350A continuous with

each Converter arc for + polarity stick and wire processes, as well as for arc-air gouging. (See Figure B.1.)

FIGURE B.1 – MULTI-WELD SYSTEM

MULTI-WELD SYSTEM

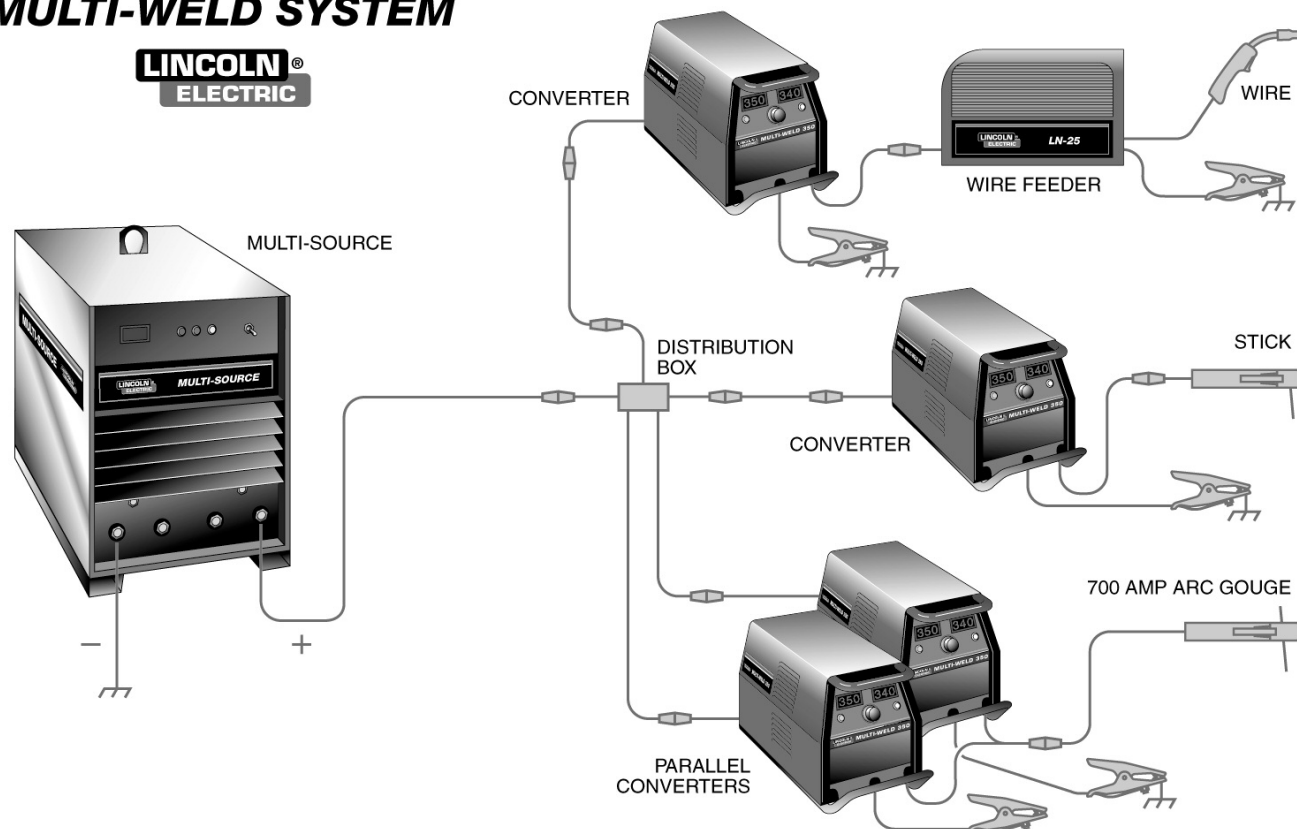

The MULTI-WELD® 350 is a DC to DC Converter that converts higher voltage/lower current input power to lower voltage/higher current output power with over 90% efficiency.

For example, a single 600A continuous rated 70-80V power source could supply up to five MULTI-WELD® 350 converters, each wire welding at 300 amps, or about ten converters for stick welding at 150 amps with 26-29V at the arcs.

The MULTI-WELD® 350 Arc Converter is a single "world" model built to IEC and CSA standards and meeting the specific needs inherent to construction site welding:

Versatile

- Constant Current (CC) mode for stick and gouging. Includes Hot Start and Arc Force controls to optimize CC performance, and can be paralleled for higher

capacity welding and arc gouging.

- Constant Voltage (CV) mode for positive polarity cored and solid wire welding with arc-powered feeders (such as the LN-25).

Portable

- The MULTI-WELD® 350 can be moved quickly. The light-weight Converter is easy to carry or pull and is small enough to fit through a 15" (38 cm) diameter or 12" x 16" (31x 41 cm) elliptical man-hole.
- The Converter is powered by the welding cable from the DC power source, without the safety hazard of high AC input supply voltages.
- Welding controls are near the arc without long control cables, and a receptacle is provided for an optional remote for even closer user output control.

MULTI-WELD® 350



OPERATION

Simple

- Easy installation with 10 ft. (3 m) work clip lead and user preference quick-connect “pig-tails” for input and electrode weld cables.
- Easy setup with only a few intuitive welding controls and lit displays. This includes a single Power/Mode switch with Input level light, and a single presettable Output Control with separate digital meters for Amps and Volts, featuring post-weld five second memory display.
- Easy Service with quick-to-replace cable “pig-tails” and “plug-in” assembly modules, including accessible PC boards and interchangeable “plug-n-play” panel instruments.

Robust

- Capacity is rated for continuous operation at 350 amps in 50°C (122°F) ambient temperature, and can be paralleled to multiply CC mode output rating.
- Overload protection is provided with electronic limiting of output current, and with thermostat and over-voltage shutdown protection that automatically reset.
- Outdoor operation protected with sealed control and power electronics compartments, with sealed inter-connections, housing “potted” circuit boards, and using “Central-Air” cooling with “Fan-As-Needed” for less dirt intake.
- Handling (and mishandling protection) is enhanced with light, but durably designed, aluminum construction with front to back, top and bottom, handles (also serving as “roll bar” and skid), and a sheet metal shell attached with 1/4" steel threaded fasteners.

RECOMMENDED EQUIPMENT AND PROCESSES

DC power sources capable of supplying the required system buss current, at above 60 volts, may be used. It is recommended that this power source have lower output inductance (choke) such as the Lincoln Electric DC-1000, DC-655 or DC-600 set for maximum output in CC mode. The power source output VA capacity should be 10% greater than the sum of the maximum VA of the converter arcs, which may all be simultaneously welding or gouging:

$$\text{Power Source (Volts x Amps) capacity} > 1.1 \times \text{Sum of Converters' (Volts x Amps) arcs}$$

DISTRIBUTION BOX

The Multi-Weld Distribution Box (K1736-1) is available for interconnection of the Multi-System using the same “pig-tail” connection method provided with the MULTI-WELD® 350 converter. Six cable strain-relief ports are provided for connection of up to (12) cables for distribution or “daisy-chain” inter-connection to other boxes. Four “pig-tail” leads (see below) are included with the Box.

“PIG-TAIL” LEADS AND CONNECTORS

Accessory “pig-tail” leads and Twist-Mate connectors are available from Lincoln for extra connections to the MULTI-WELD® 350 or the Distribution Box:

Order No.	Description:
CL012705	22 in.(56 cm) long 2/0 (70 mm ²) cable with 0.5 in.(13 mm) hole lug and cut-off ends.
K852-70	Twist-Mate male insulated plug for 1/0-2/0 (50-70 mm ²) cable.
K852-95	Twist-Mate male insulated plug for 2/0-3/0 (70-95 mm ²) cable.
K1759-70	Twist-Mate female insulated receptacle for 1/0-2/0 (50-70 mm ²) cable.
K1759-95	Twist-Mate female insulated receptacle for 2/0-3/0 (70-95 mm ²) cable.

MULTI-WELD® 350



OPERATION

REMOTE OUTPUT CONTROL OPTIONS

The MULTI-WELD® 350 is provided with a 6-pin remote receptacle to permit use with the 25 ft.(7.6 m) K857 or 100 ft. (30.4 m) K857-1 Remote Output Control options.

CV MODE WIRE WELDING

The Converter in CV mode was designed for use with an arc-powered wire feeder like the LN-25. The Converter output is always “hot” when the mode switch is not OFF. Therefore it is recommended that the LN-25 model be equipped with the internal contactor in order to have a “cold” electrode when the gun trigger is released.

The CV mode recommended processes are positive (+) polarity wire welding within the output capacity of the Converter, including:

Flux Cored Arc Welding (FCAW)

Innershield:	NS3M (5/64-3/32) NR305 (.068)
Outershield:	OS-70 (1/16-5/64) OS-71 (.045-1/16) MC-710 (.045-5/64)

Gas Metal Arc Welding (GMAW)

Carbon Steel: L50/56 (.030-1/16)

CC MODE STICK WELDING AND GOUGING

The CC mode recommended processes are positive (+) polarity stick and arc gouging within the output capacity of single, or paralleled, Converters, including:

Shielded Metal Arc Welding (SMAW)

E6010/6011:	FW5P/180 (3/32-1/4) “fast-freeze”
E6013:	FW37 (3/32-3/16) “fill-freeze”
E7010/8010:	SA85/70+ (3/32-7/32) “fast-freeze” HT pipe
E7018/7028:	JW LH70/3800 (3/32-5/32) “low-hydrogen”
E7024/6027:	JW1,3/2 (1/8-5/16) “fast-fill”

Arc Air Carbon (AAC)

Gouging: Carbons (5/32-3/8)

OPERATION

FIGURE B.2 – FRONT PANEL CONTROLS

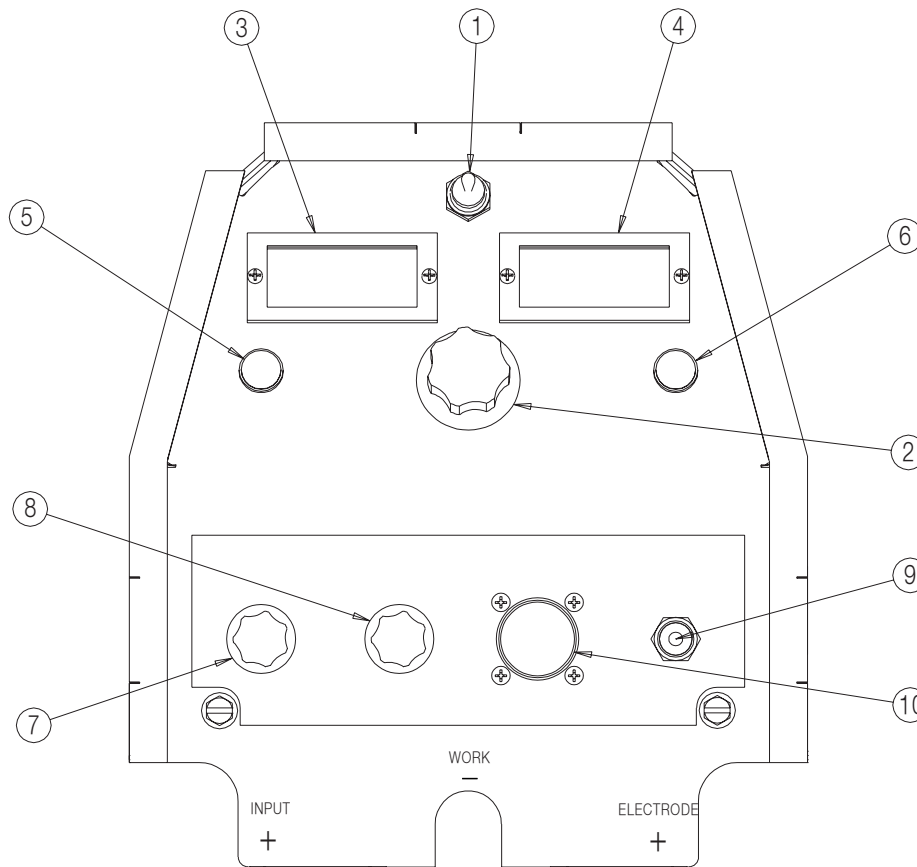

FRONT PANEL CONTROLS

The numbered items of Figure B.2 match the numbered items described below:

These few instruments and controls are basic to the operation and monitoring of the Converter. They are intuitively laid out so that the panel left side is weld current related, and the right side is weld voltage related:

(1) **Input Power/ Mode Switch** has three positions:

Center is OFF, which shuts off input power to the Converter.

- Neither displays nor output is on if in OFF position.

Left is on for CC (constant current) welding mode.

- Only AMPS digital meter is lit, displaying the preset current setting.
- Output will be on at o.c.v. (open circuit voltage).

Right is on for CV (constant voltage) welding mode.

- Only VOLTS digital meter is lit, displaying the preset voltage setting.
- Output will be on at the output voltage setting.

(2) **Output Control** has 3-3/4 turn resolution with slip-clutch to prevent control pot damage.

In CC mode it presets AMPS (30-350A range) when not welding and adjusts actual arc current while welding.

In CV mode it presets VOLTS (15-40v range) when not welding and adjusts actual arc voltage while welding.

(3) **AMPS Digital Meter** is a 3-1/2 digit LED meter which displays:

Preset AMPS in CC mode when not welding.

“Blank” in CV mode when not welding.

Actual AMPS while welding in both CC and CV modes.

MULTI-WELD® 350



Average AMPS for about 7 seconds after welding stops in CC and CV modes only.

- The 5 second memory display is indicated by the display's left-most decimal point blinking, and is interrupted if arc is restarted.

Accuracy of Actual AMPS is within 3%, and typically within 10 amps of Preset.

- An Actual AMPS meter calibration adjustment trimmer is provided. (See the **Maintenance** section).

Two front screws secure the meter bezel, which holds a replaceable spatter shield lens (Lincoln part no. T14807-9).

(4) VOLTS Digital Meter is a 3-1/2 digit LED meter which displays:

Preset VOLTS in CV mode when not welding.

"Blank" in CC mode when not welding.

Actual VOLTS while welding in both CV and CC modes.

Average VOLTS for about 7 seconds after welding stops in CV and CC modes only.

- The 7 second memory display is indicated by the display's left-most decimal point blinking, and is interrupted if arc is restarted.

Accuracy of Actual VOLTS is within 3%, and typically within 1 volt of Preset.

- An Actual VOLTS meter calibration adjustment trimmer is provided. (See the **Maintenance** section).

Two front screws secure the meter bezel, which holds a replaceable spatter shield lens.

(5) Thermal Shutdown (yellow) Light turns on if output is shutdown because internal overheating has occurred. (See **Over Temperature Shutdown** in this section).

(6) Input Voltage (green) Light indicates appropriate level of input supply voltage:

"On" for adequate input voltage over 50 V for CC or CV mode.

"Off" for inadequate input voltage under 50 V, no input or Power Switch OFF.

NOTE: If green light is "blinking," the input voltage may be drifting above and below the 50 V level due to loads on supply and cables. This may also cause the input contactor to "chatter."

RECESSED PANEL CONTROLS

These instruments are recessed behind a screw-secured hinged cover panel, and are not typically required for normal operator access. They may be left covered, as factory set, or set up as desired with or without the hinged cover secured:

(7) Hot Start Control is provided to enhance arc starting in both CC and CV modes with an extra output "boost" at the arc strike that returns to the setting level in less than a second (about 0.30 sec. in CC mode, and 0.045 sec. in CV mode). This extra Hot Start amplitude is adjustable from "0" (no extra) to "10" (100% of setting extra), with the factory set "5" (center) position typically good for most weld starting. However, "0" may provide smoother starting for fine wire CV MIG.

(8) Arc Force Control is only functional in the CC mode with Stick/Gouge slope. (See below). Arc Force prevents "stubby" of the electrode by providing extra weld current if the arc voltage drops below about 14 V. This extra weld current is adjustable from "-10" (no extra) to "+10" (60% of setting extra), with the factory set "0" (center) position typically good for most welding.

(9) CC Slope Switch is provided to enhance stick welding on "fast-freeze" type electrodes (such as E6010 and E7010) typically used on pipe welding applications for fast root pass vertical down "drag" technique (not "whipping"). For this type of application, improved operating appeal may be obtained if the CC Slope is switched from the factory set STICK/GOUGE position to the PIPE position.

NOTE: The PIPE position uses a "drooping" type slope (~22v/100A), so preset current (not actual current) accuracy may be affected if arc length voltage is not maintained at the typical 28 V used for these electrodes. Typically this error should not be more than about 10 A.

(10) Remote Control Receptacle is provided to permit the use of an optional Remote output control to provide operator control even closer to the arc.

Connecting the Remote plug to this receptacle automatically transfers output control from the panel Output Control (item (2) above) to the Remote pot control, which will function the same but with only single-turn resolution.

Disconnecting the Remote plug from this receptacle automatically transfers output control back to the panel Output Control (item (2) above).

Remote output On/Off switching can also be done through this Remote Control receptacle by performing the following wiring changes:

1. Making sure the input to the Converter is removed, remove the case wraparound.
2. Locate the 4-pin plug (P21) on the back panel of the control box module, and cut the jumper lead looping from the back of the plug. (Refer to the Wiring Diagram in the **Electrical Diagrams** section.) Insulate the cut lead ends and leave long enough to possibly splice back together again at some future time.
3. Replace the case wraparound.
4. Connect a user-provided remote switch between pins D and E of an MS3106A-18-12P plug (Lincoln part no. S12020-27 with S12024-1 cable clamp). See the diagram below:

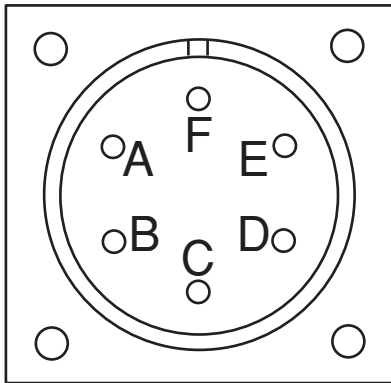

Pin:	Remote Function:
A	Max. of 10K pot
B	Wiper of 10K pot
C	Min. of 10K pot
D	Output Switch
E	Output Switch
F	No connection

5. Connect this switch plug to the MULTI-WELD® 350 Remote Control Receptacle (10) with switch opened. Closing the switch activates the Converter output.

PARALLELED CONVERTERS

MULTI-WELD® 350 converters that are paralleled (see **INTER-CONNECTION OF CONVERTERS** in the **Installation** section) must each be set up in the same manner in order to manage the arc current drawn from each:

1. Set to CC mode with CC SLOPE switch set to STICK/GOUGE.
2. Preset Output Controls of both paralleled Converters to ~1/2 desired total AMPS.

If arc current from each Converter gets too out of balance (primarily a problem if trying to use CV mode) the hotter running Converter could go into current-limiting and/or Thermal shutdown (See **OVER-TEMPERATURE SHUTDOWN** in the **Operation** section.) This might then overload the other, or at least interrupt the operator's process. However, no damage will occur to the Converters.

REMOTE CONTROL OF PARALLELED CONVERTERS

(FOR CC STICK/GOUGE MODE ONLY)

Full Range remote control can be accomplished with a separate optional Remote output control (see the **Operation** section) connected to each Converter. The current contribution of each Converter will depend on its remote output setting.

Partial Range remote control can be accomplished with a single Remote Control connected to the output Converter. The input Converter must be preset with its panel Output Control to below the minimum desired output range. The Remote Control, connected to the output Converter, will control its output to add to the preset level.

Remote Output On/Off switching may be set up for each of the paralleled Converters. Electrically isolated switches must be used to activate each separately but simultaneously.

TRANSPORTING AND STORAGE OF THE MULTI-WELD® 350

CABLE HANDLING

The input and electrode cables are easily disconnected from the quick-connect "pig-tails." The Work lead can be reeled around the MULTI-WELD® 350 case cradled by the base skid handles, to which the clip can be secured.

MULTI-WELD® 350



TRANSPORTING

The Converter may be carried by one or two persons using the front and rear top and bottom handles. It can also be set vertically on a two wheel cart, or horizontally on a wagon, to move it longer distances.

STORAGE

The MULTI-WELD® 350 may be set on a floor, or shelf, horizontally on its skid, or vertically standing on its rear top and bottom handles.

PROTECTION FEATURES

The MULTI-WELD® 350 design features electronic protection systems to help assure reliable operation even under adverse conditions. These systems include:

FAN AS NEEDED (F.A.N.)

The cooling fan will turn on when the arc starts and remain on for about a minute after the arc is out to cool down the power components.

This feature electronically controls the fan so it does not run continuously when the power switch is turned on. This will minimize the amount of contaminate and clogging debris which may be drawn into the Converter. It enhances the "Central-Air" system design which intakes lower velocity air through the higher side louvers and blows it out through the lower back louvers with higher velocity.

OVER-VOLTAGE PROTECTION

The MULTI-WELD® 350 input contactor will open if the input supply voltage is above 113 VDC, and will automatically reclose if the voltage drops back below. During Over-Voltage Shutdown the panel displays will be as appropriate for the non-welding mode. (See **FRONT PANEL CONTROLS** in this section.)



CAUTION

When the contactor recloses, the output of the Converter will reactivate. Switching OFF input power prevents unexpected reactivation.

This feature protects internal components of the Converter from excessive voltage levels.

OVER-CURRENT PROTECTION

The maximum output current of the MULTI-WELD® 350 is electronically limited, to protect internal power components, so as not to exceed about 375 amps average and 500 amps peak. When the current load starts to exceed these limits, the output is reduced (lower voltage) to sustain these maximum levels until the current is reduced, even to a shorted output.

Prolonged output at this maximum current limit level may eventually overheat the Converter's internal power components, causing over-temperature shutdown. (See following section.)

Short circuit protection is also provided to reduce maximum output current to about 200 amps, if the output voltage is reduced, by loading or current limiting, to below 14 volts for over 7 seconds (indicating a shorted output). The output current must be interrupted to reset this reduced protective level.

This maximum 200 amp short circuit level will allow using the MULTI-WELD® 350 for "pipe-thawing" applications without causing over-temperature shutdown. (See following section.)

OVER-TEMPERATURE SHUTDOWN

A second over-load protection switch in the Imbalance Protector Module was added to MULTI-WELD® 350 models with codes 10736 and higher. This module senses for an imbalance of current between the paralleled Chopper boards by sensing the differential choke voltage. If this voltage exceeds 1 V for a sustained time, the Imbalance Protector will also activate over-temperature shutdown to protect the higher current Chopper board from over heating.



CAUTION

When the thermostat resets, the output of the Converter will reactivate. Switching OFF input power prevents reactivation but also shuts off the cooling fan, which prolongs the reset time.

During Over-Temperature Shutdown the panel displays will be as appropriate for the non-welding mode. (See **FRONT PANEL CONTROLS** in this section.) The fan will remain running and the Thermal Shutdown (yellow) Light will be lit until reset. Typically, if shutdown occurs repeatedly below 300 amps output with fan running, imbalance of the Chopper board current may likely be the cause.

MULTI-WELD® 350



Return to Section TOC
Return to Master TOC
Return to Section TOC
Return to Master TOC
Return to Section TOC
Return to Master TOC
Return to Section TOC
Return to Master TOC

Return to Section TOC	Return to Section TOC	Return to Section TOC	Return to Section TOC
Return to Master TOC	Return to Master TOC	Return to Master TOC	Return to Master TOC

MULTI-WELD® 350



TABLE OF CONTENTS - ACCESSORIES SECTION -

Accessories	Section C
Options/Accessories	C-2
Field Installed Options	C-2
Semiautomatic Welding Accessories	C-2
Connection of Lincoln Electric Wire Feeders	C-2
Connection of the LN-25	C-3

Return to Master TOC

Return to Master TOC

Return to Master TOC

Return to Master TOC

MULTI-WELD® 350



OPTIONS/ACCESSORIES

The following options/accessories are available for your MULTI-WELD® 350 from your local Lincoln Distributor.

FIELD INSTALLED OPTIONS

K1736-1 DISTRIBUTION BOX - Makes connecting up to 10 MULTI-WELD® 350s quick and easy. Contains copper bus bar for connecting multiple “pig-tails.” Four “pig-tails” included.

K857 25 ft. (7.5 m) or K857-1 100 ft. (30.4 m) REMOTE CONTROL - Provides 25 ft. or 100 ft. (7.5 m or 30 m) of remote output control. Connects to 6-pin receptacle on front of MULTI-WELD® 350.

WELDING CABLE CONNECTORS

Twist-Mate™ plug for fast connection of additional MULTI-WELD® 350s.

K852-70 - Twist-Mate male plug for 1/0-2/0 (50-70 mm²) cable.

K852-90 - Twist-Mate male plug for 2/0-3/0 (70-95 mm²) cable.

K1759-70 - Twist-Mate female plug for 1/0-2/0 (50-70 mm²) cable.

K1759-90 - Twist-Mate female plug for 2/0-3/0 (70-95 mm²) cable.

SEMI-AUTOMATIC WELDING ACCESSORIES

K449 LN-25 WIRE FEEDER - The LN-25 is perfect for use with the MULTI-WELD® 350. It is designed to run “across-the-arc” with no control cables. This portable wire feeder offers constant wire feed speed in a rugged case.

CONNECTION OF LINCOLN ELECTRIC WIRE FEEDERS



WARNING

ELECTRIC SHOCK can kill.



- Only qualified personnel should perform this maintenance.
- Turn the input power OFF at the disconnect switch or fuse box before working on this equipment.
- Do not touch electrically hot parts.

MULTI-WELD® 350



ACCESSORIES

CONNECTION OF THE LN-25 TO THE MULTI-WELD® 350 “ACROSS THE ARC” (SEE FIGURE C.1.)

1. Shut the welder off.
2. Connect the electrode cable from the LN-25 to the “+” terminal of the welder.

NOTE: Welding cable must be sized for current and duty cycle of application.

3. Attach the single lead from the LN-25 to the work using the spring clip on the end of the lead. This is only a sense lead – it carries no welding current.



CAUTION

If you are using an LN-25 without an internal contactor, the electrode will be “HOT” when the MULTI-WELD® 350 is turned ON.

4. Set the MODE switch to “CV.”
5. Adjust wire feed speed at the LN-25.
6. Adjust the HOT START CONTROL to the desired level. (Use “O” for fine wire.)
7. Set VOLTMETER switch to the positive position.

**FIGURE C.1
MULTI-WELD® 350/LN-25 ACROSS THE ARC CONNECTION DIAGRAM**

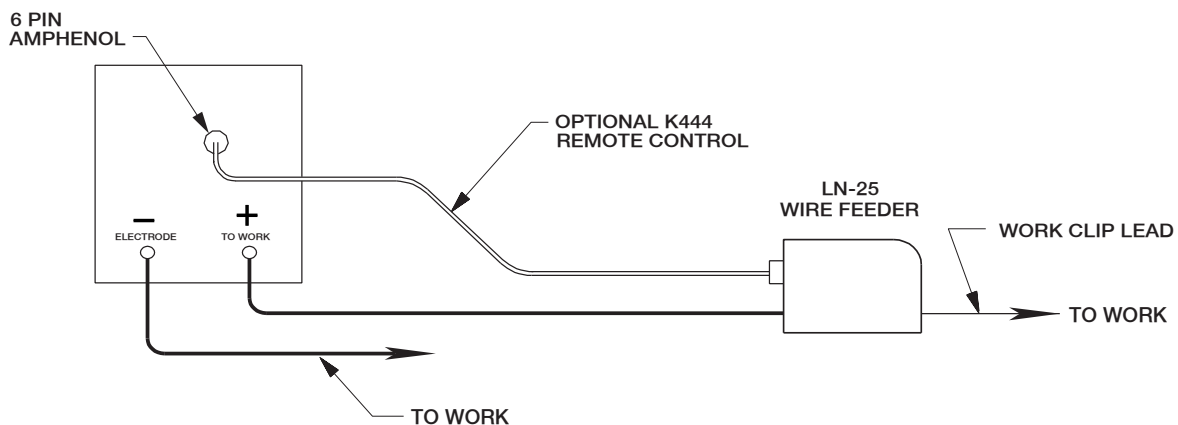

MULTI-WELD® 350



Return to Section TOC
Return to Master TOC

Return to Section TOC
Return to Master TOC

Return to Section TOC
Return to Master TOC

Return to Section TOC
Return to Master TOC

MULTI-WELD® 350



TABLE OF CONTENTS - MAINTENANCE SECTION -

Maintenance	Section D
Safety Precautions	D-2
Maintenance.....	D-2
Digital Meter Calibration.....	D-2
Service	D-3
Major Component Location.....	D-3

Return to Master TOC

Return to Master TOC

Return to Master TOC

Return to Master TOC

MULTI-WELD® 350



MAINTENANCE

SAFETY PRECAUTIONS



WARNING



ELECTRIC SHOCK can kill.

- Do not touch electrically live parts or electrode with skin or wet clothing.
- Insulate yourself from work and ground.
- Always wear dry insulating gloves.

Have qualified personnel do the maintenance work.

Always use the greatest care when working near moving parts.

If a problem cannot be corrected by following the instructions, take the machine to the nearest Lincoln Field Service Shop.

See additional warning information throughout this manual.

MAINTENANCE

The only maintenance that may be required for the MULTI-WELD® 350 is to clean out any accumulated dirt and debris. Clogging could contaminate internal components or obstruct proper cooling of the power components, resulting in premature over-temperature shut-down.

The recommended cleaning procedure is as follows:

1. Be sure to disconnect the Converter input cable to remove its input power.
2. Remove the four screws securing the rear louver panel and remove the panel to expose the cooling tunnel heatsinks. (See Figure D.1 below.)

FIGURE D.1 – TUNNEL HEATSINKS

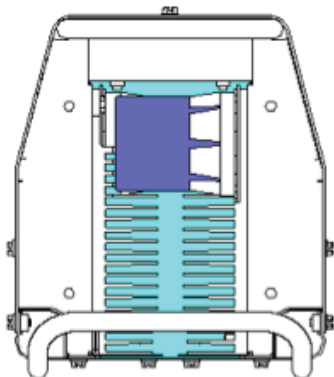

3. Holding the unit by the front handles, so the back is facing down, shake the loose debris out of the unit. Raking out the heatsink fins may be necessary for jammed debris.
4. If necessary, remove the case wraparound cover. Using the skid handles to hold the unit upside down, carefully dump out any remaining loose debris or carefully blow out using low pressure air.
5. Reassemble the cleaned out Converter by reversing the above steps.

DIGITAL METER CALIBRATION

If calibration of either digital meter is ever necessary, meter calibration adjustment trimmers are provided on the Weld Control PC board inside the Control Module. (See **Figure D.2.**) Calibration must be done with an Output current load, so meters are displaying Actual (not Preset) values. It is recommended that the calibration levels be near the rating plate values, for best accuracy, and compared to "master" meters with better than 2% accuracy.

The accuracy of Actual **AMPS** meter should be within 3% of the welding amps monitored. The **AMPS** meter trimmer (R561) is located near the center of the Weld Control PC board just below the **VOLTS** meter trimmer (R562). Clockwise rotation of the trimmer adjustment screw will decrease the meter reading.

The accuracy of Actual **VOLTS** meter should be within 3% of the welding volts monitored. The **VOLTS** meter trimmer (R562) is located near the center of the Weld Control PC board just above the **AMPS** meter trimmer (R561). Clockwise rotation of the trimmer adjustment screw will decrease the meter reading. The "master" voltmeter should be connected as close as possible to the "**ELECTRODE +**" stud and "**WORK -**" lead bolt for best accuracy.

MULTI-WELD® 350



MAINTENANCE

SERVICE

The MULTI-WELD® 350 was designed for easy service using quick-to-replace components and assembly modules that can be simply swapped out at the job site to minimize down time. More prolonged troubleshooting and repair of the module may be done later on the service bench.

Figure D.2 shows the three assembly modules of the Converter which are covered with the Case Wraparound (item (4)):

Control Module (item (1)) is removed from the Base Module assembly by removing the two bottom accessed screws and disconnecting the three sealed harness plugs from the receptacles on the back of the Control box.

This module is a sealed enclosure containing replaceable electronic components:

- Sealed back cover which mounts the internal “potted” Weld Control and Peripheral PCBs.
- Front panel with “plug-n-play” instruments that individually plug to the Control PCB.
- Interchangeable “potted” digital meters with front replaceable spatter shield lenses.
- Harness lead receptacles that connect to Base Module harness lead plugs.

Tunnel Module (item (2)) is removed from the Base Module assembly by removing the four bottom accessed screws and disconnecting the two sealed harness plugs and power leads.

NOTE: Removal of Control Module improves access to disconnect Tunnel Module power leads.

This module assembly includes:

- Heatsinked power switching (IGBT) boards and isolated diodes.
- Capacitors and potted power supply boards.
- Fan and sheet metal bulkhead tunnel and component enclosure.
- Harness lead receptacles and power leads that connect to Base Module.

Base Module (item (3)) is the mounting and connection platform for the other modules.

This module assembly includes:

- Base sheet metal with input/output connection chambers with "pigtail" leads.
- Input contactor, input diodes heat sink assembly and Work clip lead.
- Output chokes and current shunt.
- Lead harness sealed plugs connect to Tunnel and Control Module receptacles.

FIGURE D.2 – MAJOR COMPONENT LOCATIONS

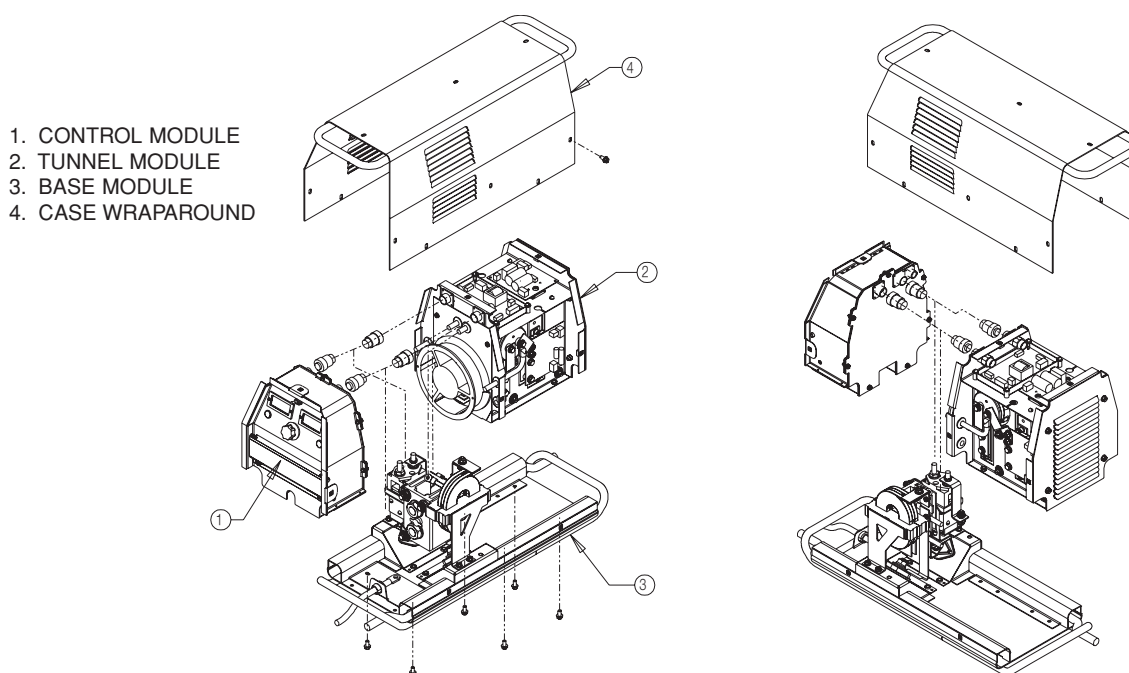

MULTI-WELD® 350



TABLE OF CONTENTS - THEORY OF OPERATION SECTION -

General DescriptionE-2

Input Power Source, Contactor and DC Buss Power Supply Board.....E-2

Power Modules and Feedback.....E-3

Analog Control Power Supply Board and Weld Control BoardE-4

Mode Selector and Output Controls.....E-5

Protection FeaturesE-6

Insulated Gate Bipolar Transistor (IGBT) OperationE-7

Pulse Width ModulationE-8

Chopper Technology Fundamentals.....E-9

MULTI-WELD 350 BLOCK LOGIC DIAGRAM

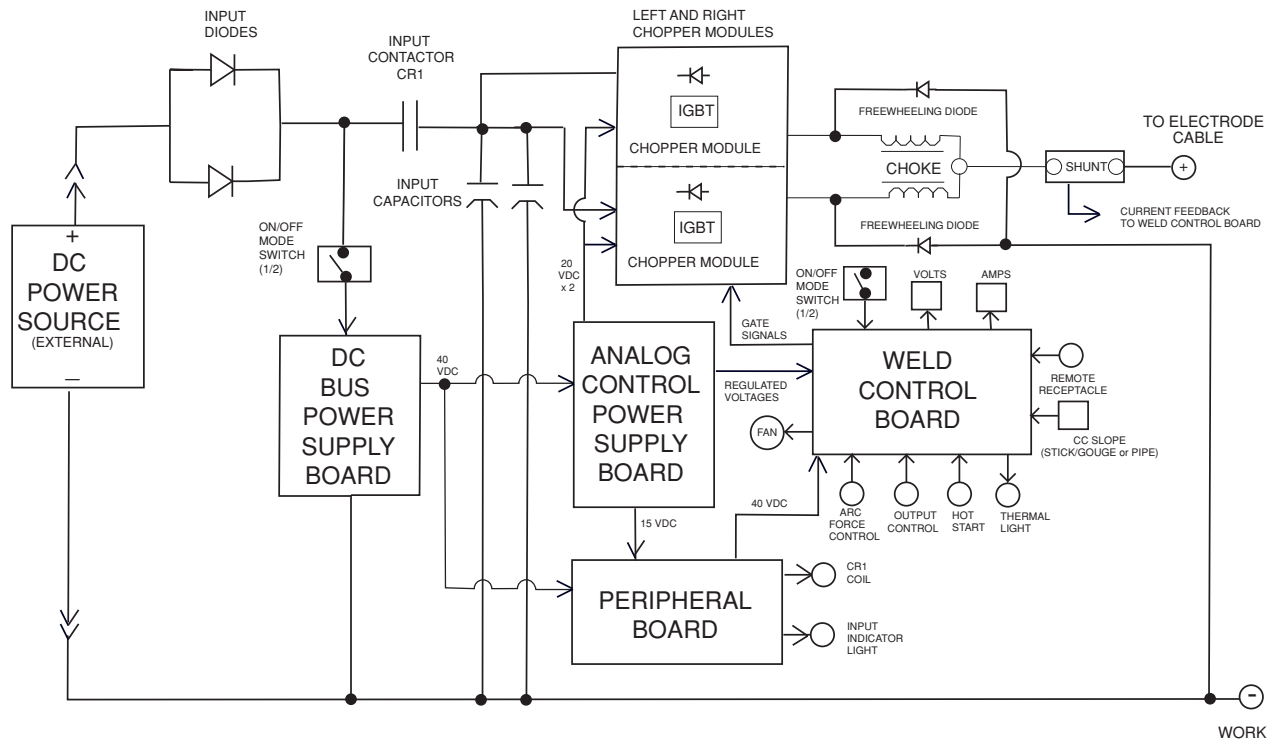

FIGURE E.1 – MULTI-WELD® 350 BLOCK LOGIC DIAGRAM

MULTI-WELD® 350



Return to Master TOC

Return to Master TOC

Return to Master TOC

Return to Master TOC

FIGURE E.2 – INPUT POWER SOURCE, CONTACTOR AND DC BUSS POWER SUPPLY BOARD

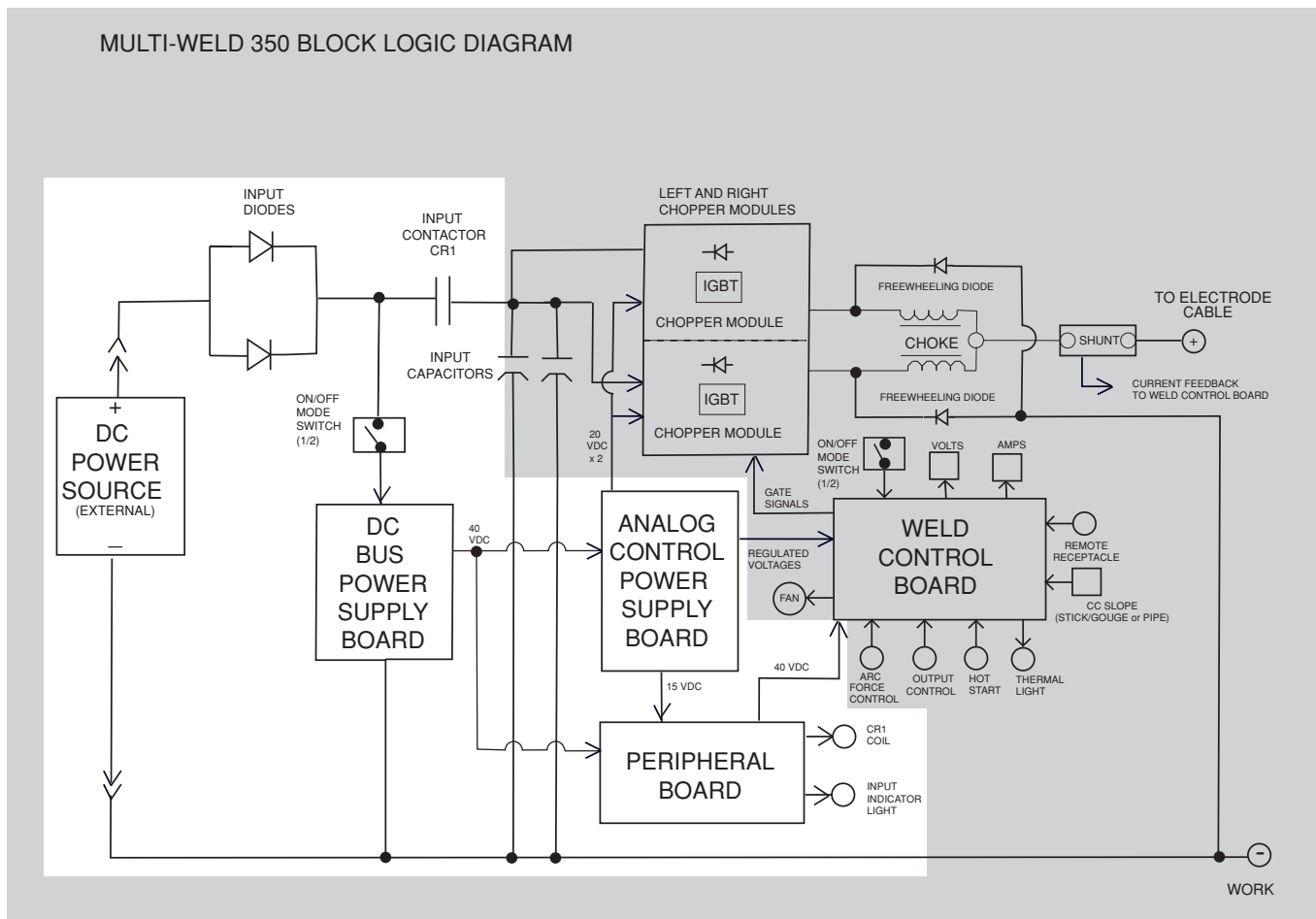

GENERAL DESCRIPTION

The MULTI-WELD® 350 Converter uses a single DC input power source to provide up to 350 continuous amps for positive polarity stick, wire processes, and arc-air gouging. The machine converts higher voltage/lower current DC input power to lower voltage/higher current DC output power with over 90% efficiency. This DC output is controlled by **Chopper Technology** to produce DC current for multi-purpose welding applications.

INPUT POWER SOURCE, CONTACTOR AND DC BUSS POWER SUPPLY BOARD

The MULTI-WELD® 350 receives DC input power from an 80 VDC buss Multi-Source (recommended), although other external DC sources such as the Lincoln Electric DC-1000, DC-655, or DC-600 can be used if they produce 50 VDC or above.

The +50 VDC supply voltage is applied to the input contactor via two large input diodes. The input contactor establishes the electrical connection between the MULTI-WELD® 350 and the power source when the ON/OFF MODE switch is activated in either the constant current (CC-stick) mode or the constant voltage (CV-wire) mode.

A 40 VDC Buss Power Supply Board supplies 40 VDC power to the Analog Control Power Supply Board, which in turn feeds regulated voltages to a Weld Control Board and 15 VDC to the Peripheral Board. The Peripheral Board powers the input contactor coil and the input indicator light on the front panel. The 40 VDC is also supplied to the Peripheral Board and is passed on to the Weld Control Board.

NOTE: Unshaded areas of Block Logic Diagram are the subject of discussion.

MULTI-WELD® 350



THEORY OF OPERATION

FIGURE E.3 – POWER MODULES AND FEEDBACK

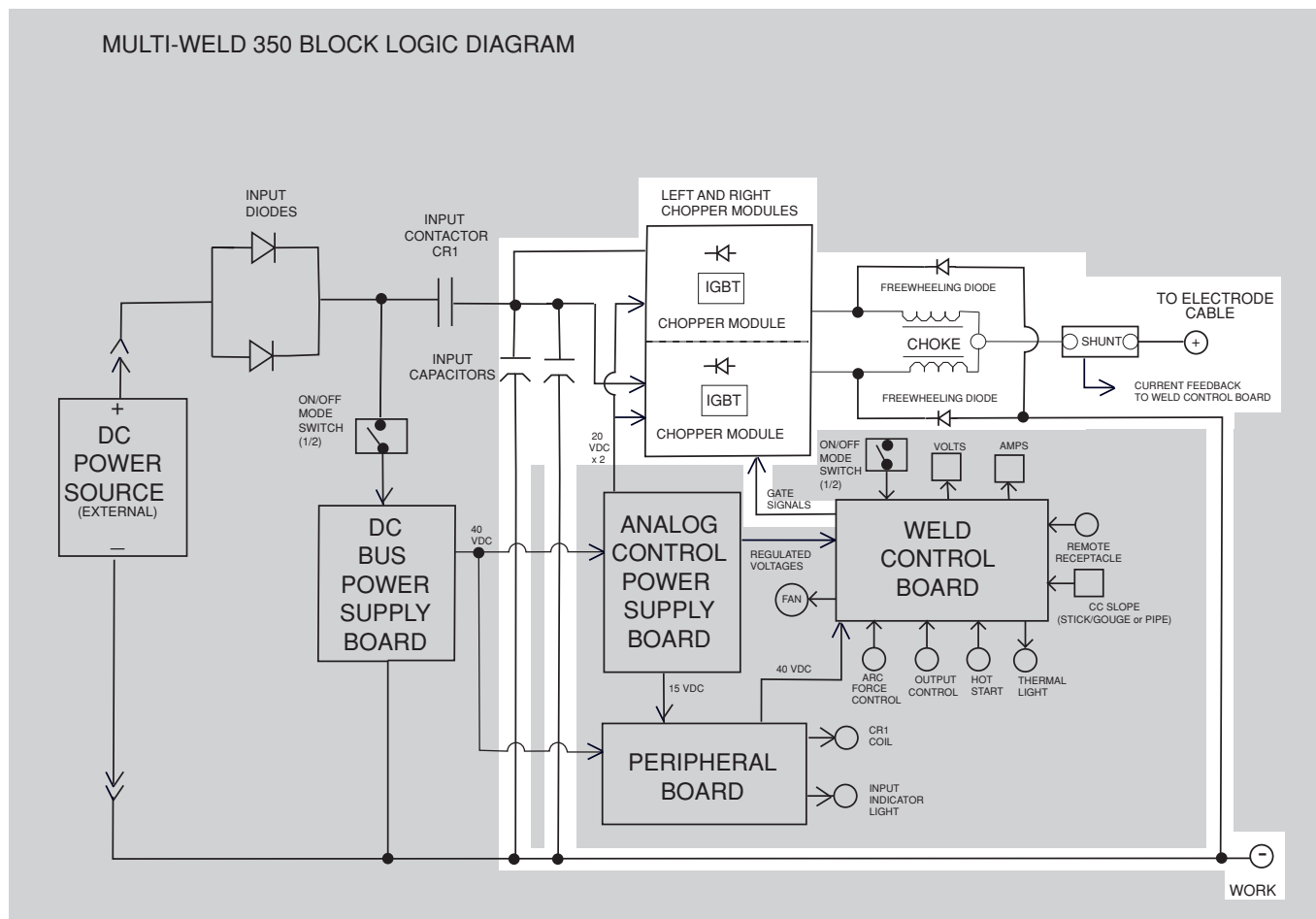

POWER MODULES AND FEEDBACK

The external DC source voltage is applied to parallel capacitors incorporated within each of the two Power (Chopper) Modules. These capacitors function as filters and as power supplies for the IGBTs. See **IGBT Operation** in this section. The IGBTs act as high-speed switches operating at 20KHZ. These devices are switched on and off by the Weld Control Board through pulse width modulation gate signals. See **Pulse Width Modulation** in this section. This “chopped” DC output is applied through choke coils and a shunt to the welding output terminals.

The chokes function as current filters. Free-wheeling diodes are incorporated in the power circuit to provide a current path for the stored energy in the chokes when the IGBTs are turned off. See **Chopper Technology** in this section.

Output voltage and current feedback information is fed to the Weld Control Board. This information is sensed from the output terminal circuits and the shunt. The feedback information is processed by the Weld Control Board, which regulates output voltage and current.

NOTE: Unshaded areas of Block Logic Diagram are the subject of discussion.

MULTI-WELD® 350



FIGURE E-4 – ANALOG CONTROL POWER SUPPLY BOARD AND WELD CONTROL BOARD

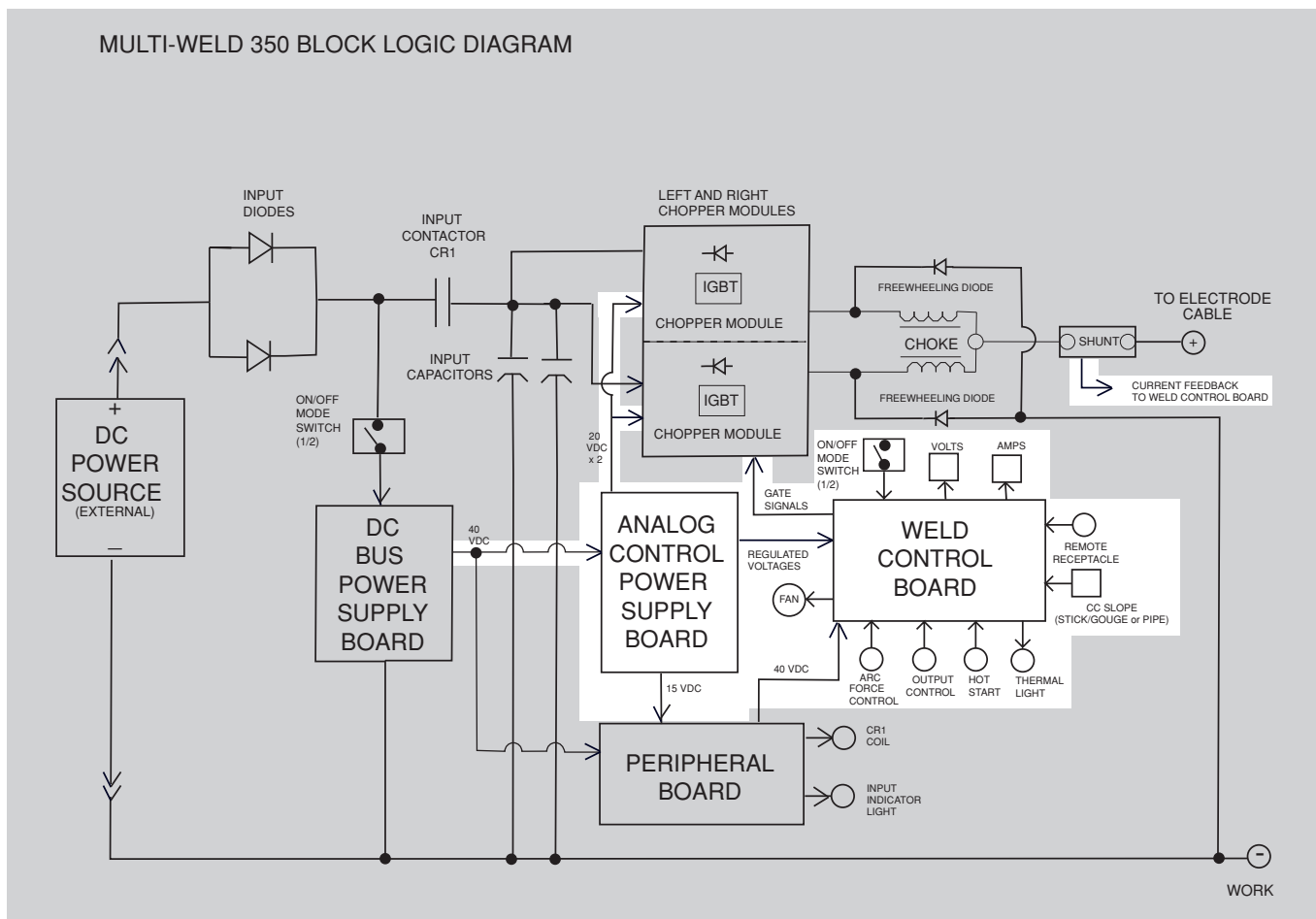

ANALOG CONTROL POWER SUPPLY BOARD AND WELD CONTROL BOARD

The Analog Control Power Supply Board, which is powered by 40 VDC delivered from the DC Buss Power Supply Board, supplies various regulated DC voltages to operate the Weld Control Board circuitry. It also provides two regulated 20 VDC supplies to operate the electronics on the Chopper Module Boards and applies a 15 VDC supply to the Peripheral Board.

The Weld Control Board monitors the operator controls (arc control, output control, hot start control, mode selector switch, CC Slope switch and the remote control receptacle). It compares these commands to the

current and voltage feedback information it receives from the shunt and output terminal circuits. The circuitry on the Weld Control Board determines how the output should be controlled to optimize welding results, and it sends the correct PWM gate signals to the IGBT driver circuits. The Weld Control Board commands the voltmeter and ammeter, which display both preset and actual (while welding) voltage and current. The Weld Control Board also controls the cooling fan motor and the thermal indicator (light).

NOTE: Unshaded areas of Block Logic Diagram are the subject of discussion.

MULTI-WELD® 350



FIGURE E.5 – MODE SELECTOR AND OUTPUT CONTROLS

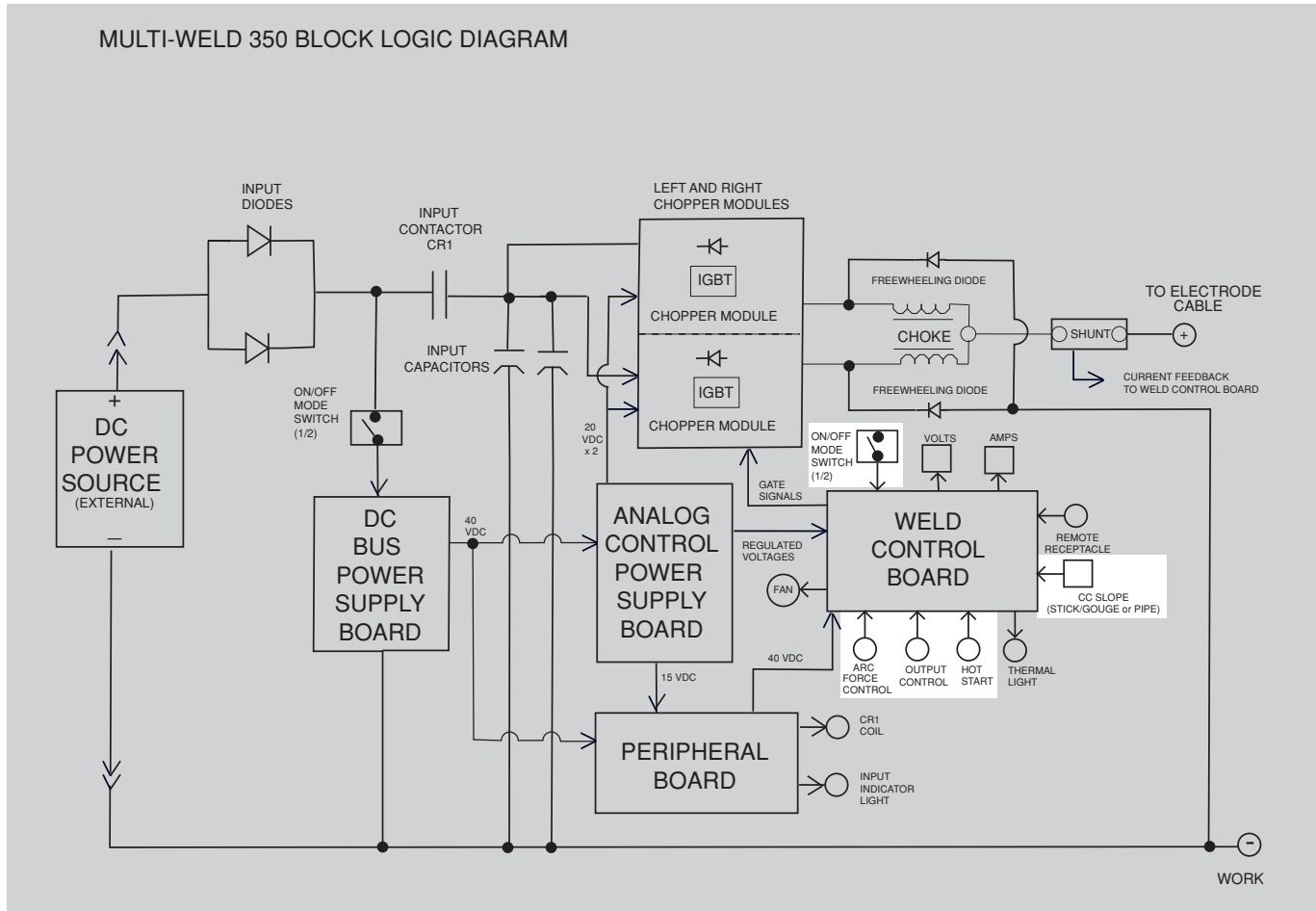

MODE SELECTOR AND OUTPUT CONTROLS

In CC mode, machine output is at open circuit voltage. The OUTPUT control presets amps in the 30 to 350 A range and then adjusts actual welding current to match the preset when welding. In CV mode, machine output is at the voltage level set at the OUTPUT control. The OUTPUT control presets volts, then adjusts the actual arc voltage to match the preset when welding.

A HOT START control is provided to enhance arc starting with an adjustable output “boost” in either CC or CV mode. The ARC FORCE control (CC mode only) provides extra weld current to prevent electrode “sticking”. An additional CC SLOPE switch improves “fast-freeze” stick electrode performance during vertical pipe welding when set to the PIPE position.

NOTE: Unshaded areas of Block Logic Diagram are the subject of discussion.

MULTI-WELD® 350



PROTECTION FEATURES

The MULTI-WELD® 350 design features electronic protection systems to help assure reliable operation even under adverse conditions. These systems include:

FAN AS NEEDED (F.A.N.)

The cooling fan will turn on when the arc starts and remain on for about a minute after the arc is out to cool down the power components.

This feature electronically controls the fan so it does not run continuously when the power switch is turned on. This will minimize the amount of contaminate and clogging debris that may be drawn into the converter. The "Central-Air" system design intakes lower velocity air through the higher side louvers and blows it out through the lower back louvers with higher velocity.

OVER-TEMPERATURE SHUTDOWN

The MULTI-WELD® 350 has a temperature sensing thermostat on the input diode heat sink to protect the power components within the converter from overheating. If this thermostat temperature exceeds about 95 degrees C (203 degrees F), the converter will electronically shut off the output and turn on the Thermal Shutdown (yellow) Light until the thermostat is cooled enough to reset.



CAUTION

When the thermostat resets, the converter output will reactivate. Switching OFF input power prevents reactivation but also shuts off the cooling fan, which prolongs the reset time.

During over-temperature shutdown the panel displays will be appropriate for the non-welding mode. However, the fan will remain running and the Thermal Shutdown Light will be lit until reset.

OVER-CURRENT PROTECTION

The maximum output current of the MULTI-WELD® 350 is electronically limited so as not to exceed 375 amps average and 500 amps peak to protect internal power components. When the current load starts to exceed these limits, the output is reduced (lower voltage) to sustain maximum levels until the current is reduced, even to a shorted output.

Prolonged output at this maximum current limit level may eventually over heat the converter's internal power components, causing over-temperature shutdown.

Short circuit protection is also provided to reduce maximum output current to about 200 amps if the output voltage is reduced, by loading or current limiting, to below 14 volts for over 7 seconds (indicating a shorted output). The output current must be interrupted to reset this reduced protective level.

This maximum 200 amp short circuit level will allow using the MULTI-WELD® 350 for "pipe-thawing" applications without causing over-temperature shutdown.



CAUTION

When the contactor recloses, the converter output will reactivate. Switching OFF input power prevents unexpected reactivation.

This feature protects internal components of the converter from excessive voltage levels.

OVER-VOLTAGE PROTECTION

The MULTI-WELD® 350 input contactor will open if the input supply voltage is above 113 VDC, and it will automatically reclose if the voltage drops back to 113 VDC. During over-voltage shutdown the panel displays will be as appropriate for the non-welding mode.

FIGURE E.6 – IGBT OPERATION

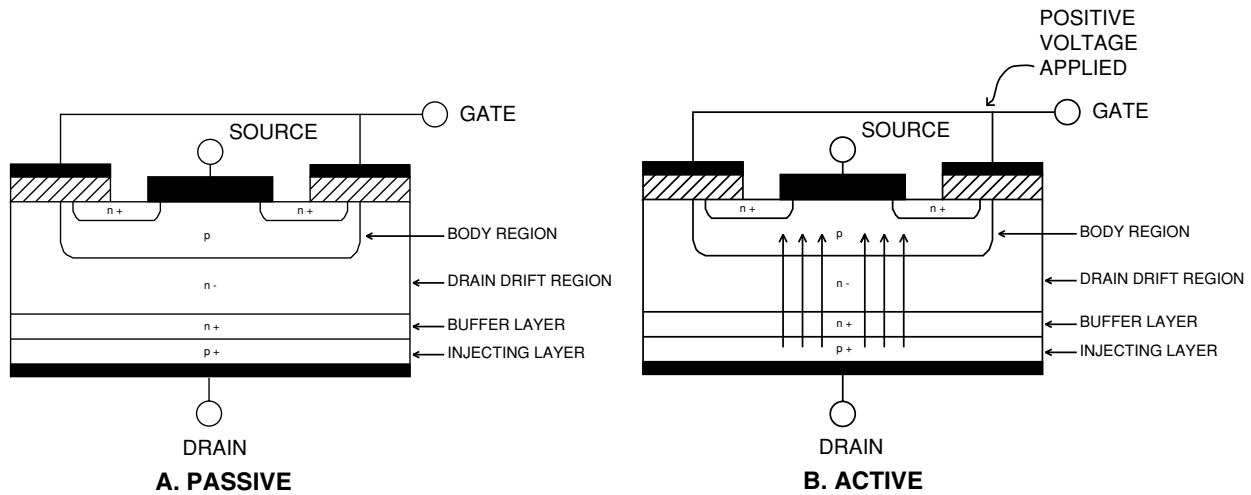

INSULATED GATE BIPOLAR TRANSISTOR (IGBT) OPERATION

An IGBT is a type of transistor. IGBTs are semiconductors well suited for high frequency switching and high current applications.

Drawing A shows an IGBT in a passive mode. There is no gate signal, zero volts relative to the source, and therefore, no current flow. The drain terminal of the IGBT may be connected to a voltage supply; but since there is no conduction the circuit will not supply current to components connected to the source. The circuit is turned off like a light switch in the OFF position.

Drawing B shows the IGBT in an active mode. When the gate signal, a positive DC voltage relative to the source, is applied to the gate terminal of the IGBT, it is capable of conducting current. A voltage supply connected to the drain terminal will allow the IGBT to conduct and supply current to circuit components coupled to the source. Current will flow through the conducting IGBT to downstream components as long as the positive gate signal is present. This is similar to turning ON a light switch.

FIGURE E.7 – TYPICAL IGBT OUTPUTS

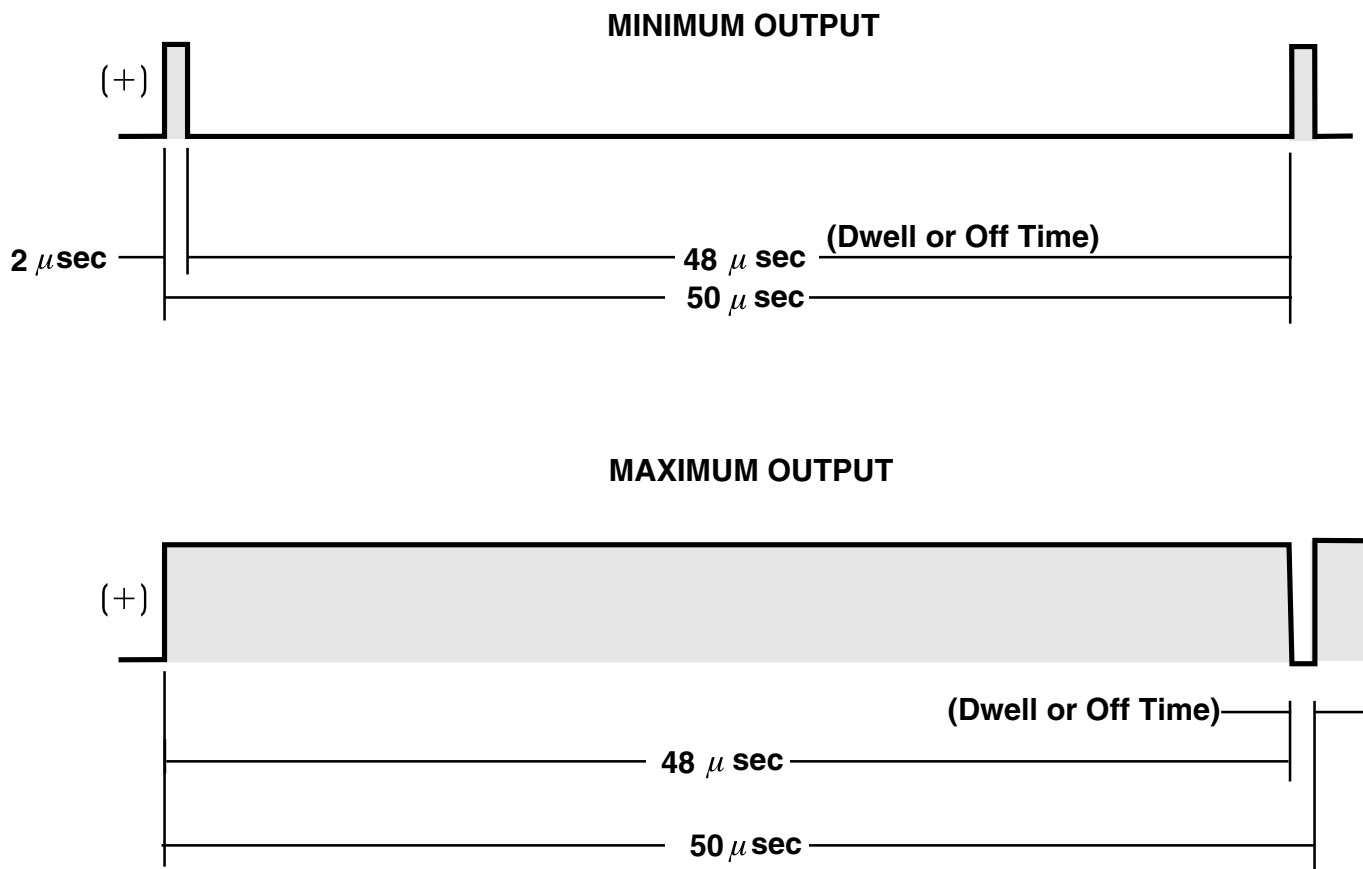

PULSE WIDTH MODULATION

The term PULSE WIDTH MODULATION is used to describe how much time is devoted to conduction in the cycle. Changing the pulse width is known as MODULATION. Pulse Width Modulation (PWM) is the varying of the pulse width over the allowed range of a cycle to affect the output of the machine.

MINIMUM OUTPUT

By controlling the duration of the gate signal, the IGBT is turned on and off for different durations during a cycle. The top drawing shows the minimum output signal possible over a 50-microsecond time period.

The positive portion of the signal represents one IGBT group conducting for 2 microsecond. The dwell time (off time) is 48 microseconds. Since only 2 microseconds of the 50-microsecond time period is devoted to conducting, the output power is minimized.

MAXIMUM OUTPUT

By holding the gate signals on for 48 microseconds and allowing only 2 microseconds of dwell time (off time) during the 50-microsecond cycle, the output is maximized. The darkened area under the top curve can be compared to the area under the bottom curve. The more darkened area under the curve, the more power is present.

CHOPPER TECHNOLOGY FUNDAMENTALS

The new era of welding machines such as the MULTI-WELD® 350 employ a technology whereby a DC source is turned on and off (chopped up) at high speed, then smoothed through an inductor to control an arc.

Hence the name “Chopper.” The biggest advantage of chopper technology is the high-speed control of the arc, similar to how inverter machines operate. A block diagram for this is as follows:

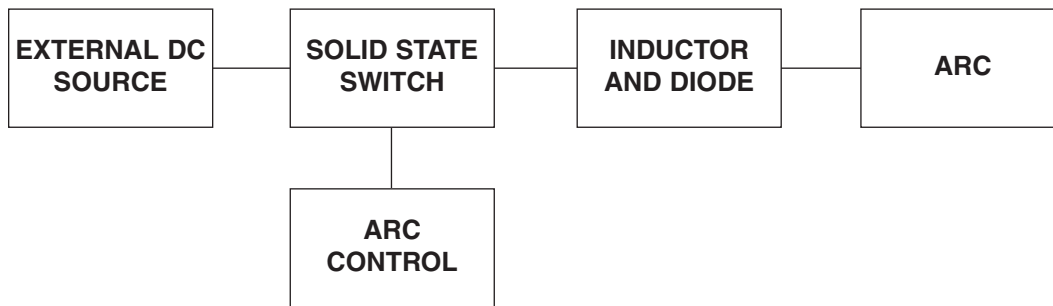

In this system, current from a DC source such as the MULTI-SOURCE is applied through a solid state switch to an inductor. By turning the switch on and off, current

in the inductor and the arc can be controlled. The following diagram depicts the current flow in the system when the switch is open and closed:

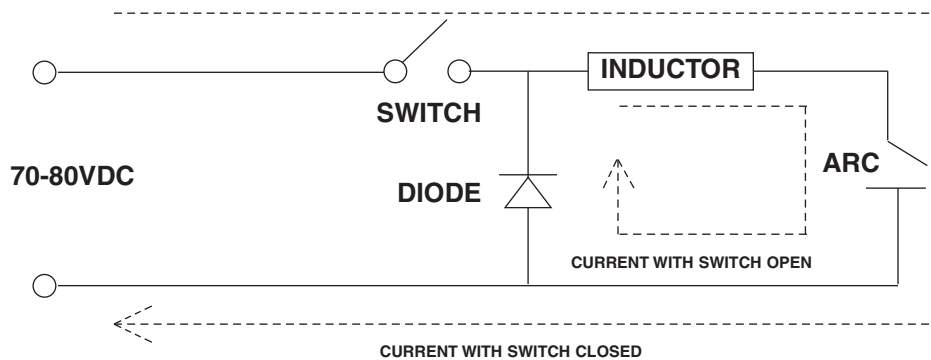

When the switch is closed, current is applied through the inductor to the arc. When the switch opens, current stored in the inductor sustains flow in the arc and through the diode. The repetition rate of switch closure is 20Khz, which allows ultra-fast control of the arc. By

varying the ratio of on time versus off time of the switch (Duty Cycle), the current applied to the arc is controlled. This is the basis for Chopper Technology: Controlling the switch in such a way as to produce superior welding.

TABLE OF CONTENTS

- TROUBLESHOOTING & REPAIR SECTION -

Troubleshooting & Repair Section	Section F
How to Use Troubleshooting Guide	F-2
PC Board Troubleshooting Procedures	F-3
Troubleshooting Guide	F-4 - F-12
Test Procedures	F-13
Case Cover Assembly Removal and Replacement Procedure	F-13
Power Module Capacitor Discharge Procedure	F-15
Input Contactor Coil Resistance and Supply Voltage Test.....	F-18
Analog Control Power Supply PC Board Test.....	F-21
DC Buss Power Supply PC Board Test	F-24
Chopper PC Board Input Voltages and Resistance Tests	F-27
Oscilloscope Waveforms	F-31
Normal Open Circuit Voltage Waveform (CC Mode) – Input Voltage Applied 75 VDC	F-31
Normal Open Circuit Voltage Waveform (CV Mode) – Output Control at Maximum.....	F-32
Normal Weld Voltage Waveform (CC Stick Mode) – Machine Loaded to 350 Amps at 34 Volts	F-33
Normal Weld Voltage Waveform (CV Mode) – Machine Loaded to 350 Amps at 34 Volts	F-34
Normal Open Circuit Voltage Waveform (CV Mode) – Output Control at Maximum.....	F-35
Replacement Procedures	F-36
Case Front Assembly Removal and Replacement	F-36
Weld Control or Peripheral PC Board Removal and Replacement	F-38
Amps/Volts Digital Meter and Potentiometer Removal and Replacement.....	F-41
Input Contactor Removal and Replacement.....	F-44
Input Diode Removal and Replacement.....	F-47
Fan Motor Assembly Removal and Replacement.....	F-50
Power Capacitor Removal and Replacement	F-53
Chopper PC Board and Diode Module Removal and Replacement	F-56
Diode Module Removal and Replacement	F-59
Retest After Repair	F-62

Return to Master TOC

Return to Master TOC

Return to Master TOC

Return to Master TOC

TROUBLESHOOTING & REPAIR

HOW TO USE TROUBLESHOOTING GUIDE



WARNING

Service and repair should be performed by only Lincoln Electric Factory Trained Personnel. Unauthorized repairs performed on this equipment may result in danger to the technician and machine operator and will invalidate your factory warranty. For your safety and to avoid Electrical Shock, please observe all safety notes and precautions detailed throughout this manual.

This Troubleshooting Guide is provided to help you locate and repair possible machine malfunctions. Simply follow the three-step procedure listed below.

Step 1. LOCATE PROBLEM (SYMPTOM). Look under the column labeled "PROBLEM" (SYMPTOMS). This column describes possible symptoms that the machine may exhibit. Find the listing that best describes the symptom that the machine is exhibiting. Symptoms are grouped into four main categories: Output Problems, Function Problems and Welding Problems.

Step 2. PERFORM EXTERNAL TESTS. The second column, labeled "POSSIBLE AREAS OF MISADJUSTMENT(S)", lists the obvious external possibilities that may contribute to the machine symptom. Perform these tests/checks in the order listed. In general, these tests can be conducted without removing the case cover.

Step 3. PERFORM COMPONENT TESTS. The last column, labeled "Recommended Course of Action" lists the most likely components that may have failed in your machine. It also specifies the appropriate test procedure to verify that the subject component is either good or bad. If there are a number of possible components, check the components in the order listed to eliminate one possibility at a time until you locate the cause of your problem.

All of the referenced test procedures referred to in the Troubleshooting Guide are described in detail at the end of this section. Refer to the Troubleshooting and Repair Table of Contents to locate each specific Test Procedure. All of the referred to test points, components, terminal strips, etc., can be found on the referenced electrical wiring diagrams and schematics. Refer to the Electrical Diagrams Section Table of Contents to locate the appropriate diagram.



CAUTION

If for any reason you do not understand the test procedures or are unable to perform the test/repairs safely, contact the Lincoln Electric Service Department for electrical troubleshooting assistance before you proceed. Call 1-888-935-3877.

MULTI-WELD® 350



TROUBLESHOOTING & REPAIR

PC BOARD TROUBLESHOOTING PROCEDURES

WARNING



ELECTRIC SHOCK can kill.

Have an electrician install and service this equipment. Turn the machine OFF before working on equipment. Do not touch electrically hot parts.

Sometimes machine failures appear to be due to PC board failures. These problems can sometimes be traced to poor electrical connections. To avoid problems when troubleshooting and replacing PC boards, please use the following procedure:

1. Determine to the best of your technical ability that the PC board is the most likely component causing the failure symptom.
2. Check for loose connections at the PC board to assure that the PC board is properly connected.
3. If the problem persists, replace the suspect PC board using standard practices to avoid static electrical damage and electrical shock. Read the warning inside the static resistant bag and perform the following procedures:

PC Board can be damaged by static electricity.



- Remove your body's static charge before opening the static-shielding bag. Wear an anti-static wrist strap. For safety, use a 1 Meg ohm resistive cord connected to a grounded part of the equipment frame.
- If you don't have a wrist strap, touch an unpainted, grounded, part of the equipment frame. Keep touching the frame to prevent static build-up. Be sure not to touch any electrically live parts at the same time.
- Tools which come in contact with the PC Board must be either conductive, anti-static or static-dissipative.

- Remove the PC Board from the static-shielding bag and place it directly into the equipment. Don't set the PC Board on or near paper, plastic or cloth which could have a static charge. If the PC Board can't be installed immediately, put it back in the static-shielding bag.
- If the PC Board uses protective shorting jumpers, don't remove them until installation is complete.
- If you return a PC Board to The Lincoln Electric Company for credit, it must be in the static-shielding bag. This will prevent further damage and allow proper failure analysis.

4. Test the machine to determine if the failure symptom has been corrected by the replacement PC board.

NOTE: Allow the machine to heat up so that all electrical components can reach their operating temperature.

5. Remove the replacement PC board and substitute it with the original PC board to recreate the original problem.
 - a. If the original problem does not reappear by substituting the original board, then the PC board was not the problem. Continue to look for bad connections in the control wiring harness, junction blocks, and terminal strips.
 - b. If the original problem is recreated by the substitution of the original board, then the PC board was the problem. Reinstall the replacement PC board and test the machine.
6. Always indicate that this procedure was followed when warranty reports are to be submitted.

NOTE: Following this procedure and writing on the warranty report, "INSTALLED AND SWITCHED PC BOARDS TO VERIFY PROBLEM," will help avoid denial of legitimate PC board warranty claims.

TROUBLESHOOTING & REPAIR

Observe Safety Guidelines detailed in the beginning of this manual.

TROUBLESHOOTING GUIDE

PROBLEMS (SYMPTOMS)	POSSIBLE AREAS OF MISADJUSTMENT(S)	RECOMMENDED COURSE OF ACTION
OUTPUT PROBLEMS		
Major physical or electrical damage is evident.	1. Contact your local Lincoln Authorized Field Service Facility.	1. Contact the Lincoln Electric Service Department at 1-888-935-3877
The MULTI-WELD® 350 is completely dead. The meters do not light and the input contactor does not activate when the ON/OFF Mode Selector switch is turned on.	<ol style="list-style-type: none"> 1. Make sure the power source is working properly and supplying at least 50VDC to the MULTI-WELD® 350. The electrode cable must be positive polarity and the work cable negative polarity. 2. Check the electrode and work cables for loose or faulty connections. 	<ol style="list-style-type: none"> 1. Measure the input voltage to the MULTI-WELD® 350. It must be between 50 and 113VDC. 2. The ON/OFF Mode Selector switch (S1) may be faulty. Check and replace if faulty. See the Wiring Diagram. Also check associated wiring. 3. The input diode D1/D2 may be open. Check. See the Wiring Diagram. 4. Perform the DC Buss Supply Board Test. 5. Perform the Analog Control Power Supply Board Test. 6. The Weld Control Board may be faulty. Replace.



CAUTION

If for any reason you do not understand the test procedures or are unable to perform the test/repairs safely, contact the Lincoln Electric Service Department for electrical troubleshooting assistance before you proceed. Call 1-888-935-3877.

MULTI-WELD® 350



Return to Section TOC
Return to Master TOC

TROUBLESHOOTING & REPAIR

TROUBLESHOOTING GUIDE

Observe Safety Guidelines detailed in the beginning of this manual.

PROBLEMS (SYMPTOMS)	POSSIBLE AREAS OF MISADJUSTMENT(S)	RECOMMENDED COURSE OF ACTION
OUTPUT PROBLEMS		
The meters light, but the input contactor does not activate when the ON/OFF Mode Selector switch is turned on. The MULTI-WELD® 350 does not have output.	<ol style="list-style-type: none"> 1. Make sure the input voltage applied to the MULTI-WELD® 350 is not greater than 113VDC. 	<ol style="list-style-type: none"> 1. Check leads 330 and 303A for loose or faulty connections. See the Wiring Diagram. 2. Perform the <i>Input Contactor Coil Resistance and Supply Voltage Test</i>. 3. The Peripheral Board may be faulty. 4. The Weld Control Board may be faulty.
The Thermal Light is on. The MULTI-WELD® 350 does not have output. The fan operates normally.	<ol style="list-style-type: none"> 1. The output rating of the machine may be exceeded. See the <i>Technical Specifications</i>. 2. Wait until the machine cools and the Thermal Light goes out. The machines output should be restored. 	<ol style="list-style-type: none"> 1. The Thermostat, located on the input diode heat sink, may be faulty. 2. Check leads 306, 307, 206, 207 and plugs J22 and J11 for loose or faulty connections. See the Wiring Diagram.



CAUTION

If for any reason you do not understand the test procedures or are unable to perform the test/repairs safely, contact the Lincoln Electric Service Department for electrical troubleshooting assistance before you proceed. Call 1-888-935-3877.

MULTI-WELD® 350



TROUBLESHOOTING & REPAIR

Observe Safety Guidelines detailed in the beginning of this manual.

TROUBLESHOOTING GUIDE

PROBLEMS (SYMPTOMS)	POSSIBLE AREAS OF MISADJUSTMENT(S)	RECOMMENDED COURSE OF ACTION
OUTPUT PROBLEMS		
<p>The MULTI-WELD® 350 does not have output. The meters turn on, the input contactor activates and the Thermal light is off.</p>	<p>1. Check the welding cables for loose or faulty connections.</p>	<ol style="list-style-type: none"> 1. Check for loose or faulty connections at the Control box, the Chopper boards, and the Analog Power Supply Board. See the Wiring Diagram. 2. Check the heavy current carrying leads at the choke, the chopper boards, the shunt and the output terminals for loose or faulty connections. See the Wiring Diagram. 3. Perform the <i>Chopper Board Input Voltage and Resistance Test.</i> 4. Perform the <i>Analog Control Power Supply Board Test.</i> 5. The Weld Control Board may be faulty. Replace.



CAUTION

If for any reason you do not understand the test procedures or are unable to perform the test/repairs safely, contact the Lincoln Electric Service Department for electrical troubleshooting assistance before you proceed. Call 1-888-935-3877.

MULTI-WELD® 350



Return to Section TOC
Return to Master TOC

TROUBLESHOOTING & REPAIR

TROUBLESHOOTING GUIDE

Observe Safety Guidelines detailed in the beginning of this manual.

PROBLEMS (SYMPTOMS)	POSSIBLE AREAS OF MISADJUSTMENT(S)	RECOMMENDED COURSE OF ACTION
FUNCTION PROBLEMS		
The preset amps (CC mode) or volts (CV mode) are not adjustable.	1. The panel Output Control is disabled when a remote control device is plugged into the 6-pin remote receptacle.	<ol style="list-style-type: none"> 1. The Output Control (R1) may be faulty. Check or replace. Also check associated leads for loose or faulty connections. 2. Check all the plug connections to the Weld Control Board for loose or faulty connections. See the Wiring Diagram. 3. The Weld Control Board may be faulty. Replace.
The preset range is not correct.	1. The panel Output Control is disabled when a remote control device is plugged into the 6-pin remote receptacle.	<ol style="list-style-type: none"> 1. Make sure plug P3 is connected securely to receptacle J3 on the Weld Control Board. See the Wiring Diagram. Make certain all the jumper leads are in place. 2. Check all the plug connections to the Weld Control Board for loose or faulty connections. See the Wiring Diagram. 3. The Weld Control Board may be faulty. Replace.



CAUTION

If for any reason you do not understand the test procedures or are unable to perform the test/repairs safely, contact the Lincoln Electric Service Department for electrical troubleshooting assistance before you proceed. Call 1-888-935-3877.

MULTI-WELD® 350



TROUBLESHOOTING & REPAIR

Observe Safety Guidelines detailed in the beginning of this manual.

TROUBLESHOOTING GUIDE

PROBLEMS (SYMPTOMS)	POSSIBLE AREAS OF MISADJUSTMENT(S)	RECOMMENDED COURSE OF ACTION
FUNCTION PROBLEMS		
<p>The meters do not light in either CV or CC modes.</p>	<p>1. In the CC mode, only the AMPS meter will light. In the CV mode, only the VOLTS meter will light.</p>	<ol style="list-style-type: none"> 1. Check all the plug connections to the Weld Control Board for loose or faulty connections. See the Wiring Diagram. 2. Check the leads and connections between the meters and the Weld Control Board. See the Wiring Diagram. 3. Perform the Analog Control Power Supply Board Test. 4. The meters may be faulty. 5. The Weld Control Board may be faulty. Replace.
<p>One or both of the meter's readings are not accurate.</p>	<p>1. Make sure the test or external meter is reliable and accurate.</p>	<ol style="list-style-type: none"> 1. Check shunt feedback leads R326, 327, R226, 227, plugs P21 and P6 for loose or faulty connections. See the Wiring Diagram. 2. Check the integrity of lead 237 at plug P12 on the Weld Control Board and also at plug P31 on the Peripheral Board. 3. See the Digital Meter Calibration and Adjustment Test in the Maintenance section. 4. Perform the Analog Control Power Supply Board Test. 5. The Weld Control Board may be faulty. Replace.



CAUTION

If for any reason you do not understand the test procedures or are unable to perform the test/repairs safely, contact the Lincoln Electric Service Department for electrical troubleshooting assistance before you proceed. Call 1-888-935-3877.

Return to Section TOC
Return to Master TOC

TROUBLESHOOTING & REPAIR

TROUBLESHOOTING GUIDE

Observe Safety Guidelines detailed in the beginning of this manual.

PROBLEMS (SYMPTOMS)	POSSIBLE AREAS OF MISADJUSTMENT(S)	RECOMMENDED COURSE OF ACTION
FUNCTION PROBLEMS		
The fan motor does not run when the machine is turned on.	1. Normal operation. The MULTI-WELD® 350 utilizes a Fan On Demand system. The fan should activate when welding.	1. Carefully check for approximately 40VDC at the fan motor leads (303+ to 300-). This test must be performed while the machine is connected to a resistive load or welding. If the 40VDC is NOT present, check the associated leads and plugs for loose or faulty connections. See the Wiring Diagram. If the correct voltage IS present and the fan is not running, the fan motor may be faulty.
The fan does not run when welding.	1. The fan should turn on when the arc starts and remain on for about a minute after the arc is out.	2. If the correct voltage (40VDC) is not present in the above test, perform the DC Buss Supply Board Test . 3. The Weld Control Board may be faulty. Replace.



CAUTION

If for any reason you do not understand the test procedures or are unable to perform the test/repairs safely, contact the Lincoln Electric Service Department for electrical troubleshooting assistance before you proceed. Call 1-888-935-3877.

MULTI-WELD® 350



Return to Section TOC
 Return to Section TOC
 Return to Section TOC
 Return to Section TOC
 Return to Master TOC
 Return to Master TOC
 Return to Master TOC

TROUBLESHOOTING & REPAIR

Observe Safety Guidelines detailed in the beginning of this manual.

TROUBLESHOOTING GUIDE

PROBLEMS (SYMPTOMS)	POSSIBLE AREAS OF MISADJUSTMENT(S)	RECOMMENDED COURSE OF ACTION
WELDING PROBLEMS		
The welding output is high with no control.	<ol style="list-style-type: none"> 1. Check all input and output cables for shorts. Check the positive input and output cables for “grounded” connections to the machine’s case. 	<ol style="list-style-type: none"> 1. Check shunt feedback leads R326, 327, R226, 227, plugs P21 and P6, for loose or faulty connections. See the Wiring Diagram. 2. Check the continuity of leads 401, 301, 201, plugs P20, P22 and P31. See the Wiring Diagram. 3. Check the Output Control R1 and the associated leads. See the Wiring Diagram. 4. The Weld Control Board may be Faulty.
No control of welding output.	<ol style="list-style-type: none"> 1. The panel Output Control is disabled when a remote control device is plugged into the 6-pin remote receptacle. 2. Check the welding cables for loose or faulty connections. 	<ol style="list-style-type: none"> 1. Check the Output Control (R1) and the associated leads for loose or faulty connections. 2. Check all the plug connections to the Weld Control Board for loose or faulty connections. See the Wiring Diagram. 3. The Weld Control Board may be faulty. Replace.



CAUTION

If for any reason you do not understand the test procedures or are unable to perform the test/repairs safely, contact the Lincoln Electric Service Department for electrical troubleshooting assistance before you proceed. Call 1-888-935-3877.

MULTI-WELD® 350



Return to Section TOC
Return to Master TOC

TROUBLESHOOTING GUIDE

Observe Safety Guidelines
detailed in the beginning of this manual.

PROBLEMS (SYMPTOMS)	POSSIBLE AREAS OF MISADJUSTMENT(S)	RECOMMENDED COURSE OF ACTION
WELDING PROBLEMS		
When welding in the Stick Mode, the current changes with arc length.	<ol style="list-style-type: none"> 1. Make sure the machine settings are correct for the process being used. When stick welding, the CC Slope Switch (S2) should be in the Stick/Gouge position. 2. Check the welding cables for loose or faulty connections. 	<ol style="list-style-type: none"> 1. Check the CC Slope Switch (S2) and the associated lead connections. 2. Check all the plug connections to the Weld Control Board for loose or faulty connections. See the Wiring Diagram 3. The Weld Control Board may be faulty. Replace.
When using "fast freeze" type electrodes such as E6010 or E7010, the welding performance is poor.	<ol style="list-style-type: none"> 1. Make sure the machine settings are correct for the process being used. When stick welding with "fast freeze" type electrodes, the CC Slope Switch (S2) should be in the Pipe position. 2. Check the welding cables for loose or faulty connections. 	<ol style="list-style-type: none"> 1. Check the CC Slope Switch (S2) and the associated lead connections. 2. Check all the plug connections to the Weld Control Board for loose or faulty connections. See the Wiring Diagram. 3. The Weld Control Board may be faulty. Replace.

**CAUTION**

If for any reason you do not understand the test procedures or are unable to perform the test/repairs safely, contact the Lincoln Electric Service Department for electrical troubleshooting assistance before you proceed. Call 1-888-935-3877.

MULTI-WELD® 350



TROUBLESHOOTING & REPAIR

Observe Safety Guidelines detailed in the beginning of this manual.

TROUBLESHOOTING GUIDE

PROBLEMS (SYMPTOMS)	POSSIBLE AREAS OF MISADJUSTMENT(S)	RECOMMENDED COURSE OF ACTION
WELDING PROBLEMS		
The arc starting is not satisfactory.	<ol style="list-style-type: none"> The Hot Start Control may not be set correctly for the process being used. Make sure the Output Control is adjusted correctly for the process being used. 	<ol style="list-style-type: none"> Check the Hot Start Control (R2) and associated leads and connections. Note: The Arc Force Control and Hot Start Control are interchangeable and may be switched to aid in troubleshooting. See the Wiring Diagram. The Weld Control Board may be faulty.
When stick welding the electrode "stubs".	<ol style="list-style-type: none"> The Arc Force Control may not be set correctly for the process being used. Increase the Arc Force. Make sure the Output Control is adjusted correctly for the process being used. Check the welding cables for loose or faulty connections. 	<ol style="list-style-type: none"> Check the Arc Force Control (R3) and associated leads and connections. Note: The Arc Force Control and Hot Start Control are interchangeable and may be switched to aid in troubleshooting. See the Wiring Diagram. The Weld Control Board may be faulty.



CAUTION

If for any reason you do not understand the test procedures or are unable to perform the test/repairs safely, contact the Lincoln Electric Service Department for electrical troubleshooting assistance before you proceed. Call 1-888-935-3877.

MULTI-WELD® 350



Return to Section TOC
 Return to Section TOC
 Return to Section TOC
 Return to Section TOC
 Return to Master TOC
 Return to Master TOC
 Return to Master TOC
 Return to Master TOC

CASE COVER ASSEMBLY REMOVAL AND REPLACEMENT PROCEDURE



WARNING

Service and repair should be performed by only Lincoln Electric factory trained personnel. Unauthorized repairs performed on this equipment may result in danger to the technician or machine operator and will invalidate your factory warranty. For your safety and to avoid electrical shock, please observe all safety notes and precautions detailed throughout this manual.

If for any reason you do not understand the test procedures or are unable to perform the test/repairs safely, contact the Lincoln Electric Service Department for electrical troubleshooting assistance before you proceed. Call 1-888-935-3877.

TEST DESCRIPTION

This procedure will aid the technician in the removal and replacement of the Case Sheet Metal Cover.

MATERIALS NEEDED

3/8" Wrench or socket wrench

This procedure should take approximately 5 minutes to perform.

CASE COVER ASSEMBLY REMOVAL AND REPLACEMENT PROCEDURE (CONTINUED)

FIGURE F.1 – COVER REMOVAL DETAILS

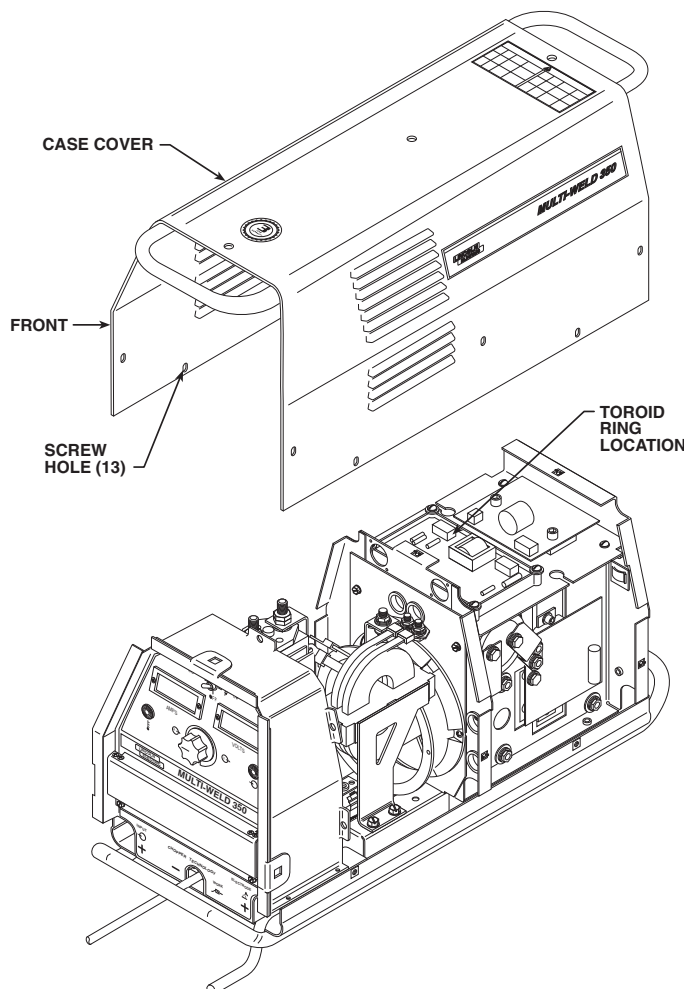

REMOVAL PROCEDURE

1. Set the CC/CV power switch to OFF.
2. Remove input power to the machine.



WARNING

ELECTRIC SHOCK can kill.

Disconnect input power before removing the case cover and performing tests or making repairs to the machine.

3. Using the 3/8" nut driver, remove the 13 sheet metal screws holding the case cover assembly in place.
4. Carefully lift the cover off the machine.

REPLACEMENT PROCEDURE

1. Be sure that the toroid rings on the top of the tunnel assembly are lying flat and will not restrict placement of the machine cover. See Figure F.1.
2. The cover fits on in one direction only. Verify front/back orientation, then carefully lower the cover into place.
3. Install the 13 sheet metal screws that hold the case cover in place.

MULTI-WELD® 350

LINCOLN
ELECTRIC

POWER MODULE CAPACITOR DISCHARGE PROCEDURE



WARNING

Service and repair should be performed by only Lincoln Electric factory trained personnel. Unauthorized repairs performed on this equipment may result in danger to the technician or machine operator and will invalidate your factory warranty. For your safety and to avoid electrical shock, please observe all safety notes and precautions detailed throughout this manual.

If for any reason you do not understand the test procedures or are unable to perform the test/repairs safely, contact the Lincoln Electric Service Department for electrical troubleshooting assistance before you proceed. Call 1-888-935-3877.

TEST DESCRIPTION

This procedure will insure that the large capacitor in each Chopper Power Module has been discharged. This procedure should be performed whenever work is to be attempted on or near the Power Modules.

MATERIALS NEEDED

- 3/8" Wrench or socket wrench
- Volt/Ohmmeter
- Resistor (25-1000 ohms and 25 watts minimum)
- Jumper leads

This procedure should take approximately 15 minutes to perform.

POWER MODULE CAPACITOR DISCHARGE PROCEDURE (CONTINUED)

FIGURE F.2 – POWER MODULE CAPACITOR TERMINAL DISCHARGE

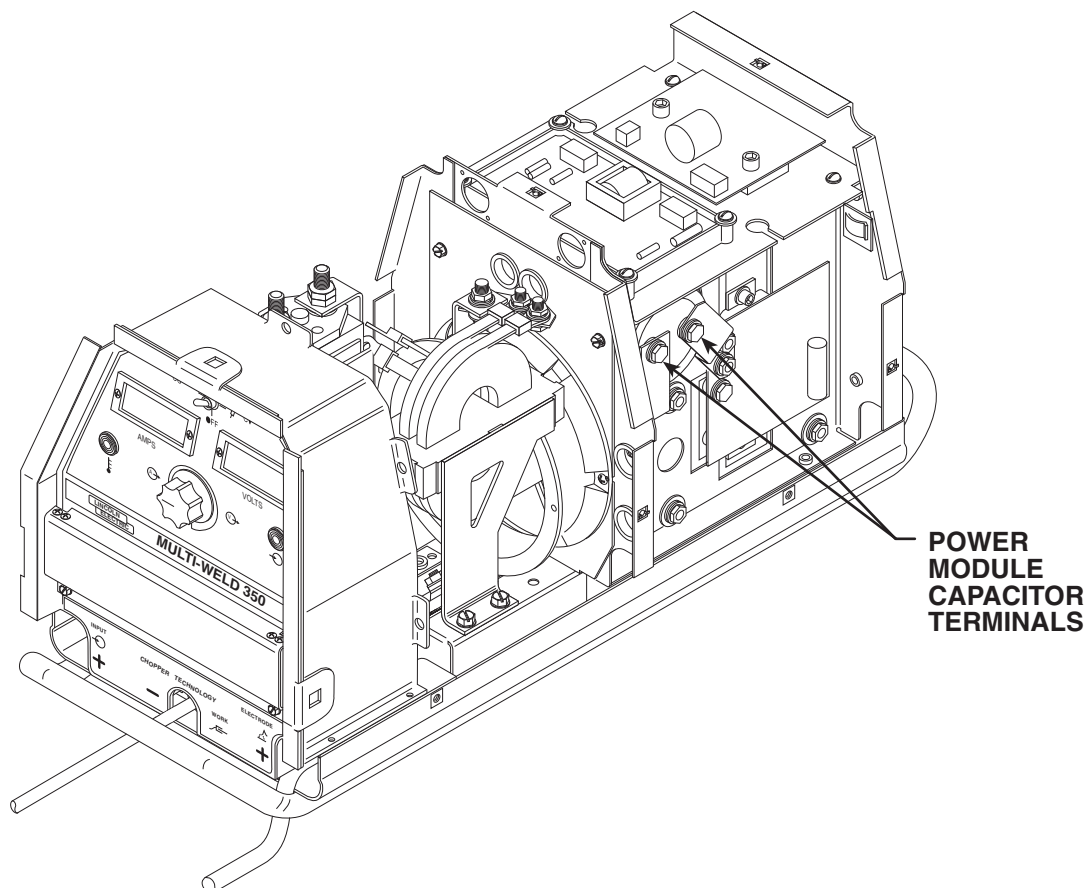

PROCEDURE

1. Set the CC/CV power switch to OFF.
2. Remove input power to the machine.

WARNING

ELECTRIC SHOCK can kill.

Disconnect input power before removing the case cover and performing tests or making repairs to the machine.

3. Perform the **Case Cover Assembly Removal Procedure**.

4. Locate the power module capacitors on the right and left sides of the tunnel assembly. See Figure F.2.
5. Using the resistor and jumper leads, CAREFULLY discharge the capacitor terminals. **NEVER USE A SHORTING STRAP FOR THIS PURPOSE.** DO NOT TOUCH THE TERMINALS WITH YOUR BARE HANDS. Repeat the procedure for the second capacitor.
6. Using the volt/ohmmeter, check the voltage across the capacitor terminals. It should be zero volts.

MULTI-WELD® 350

LINCOLN
ELECTRIC

POWER MODULE CAPACITOR DISCHARGE PROCEDURE (CONTINUED)

SYSTEMS CHECK AND REPAIR PROCEDURE

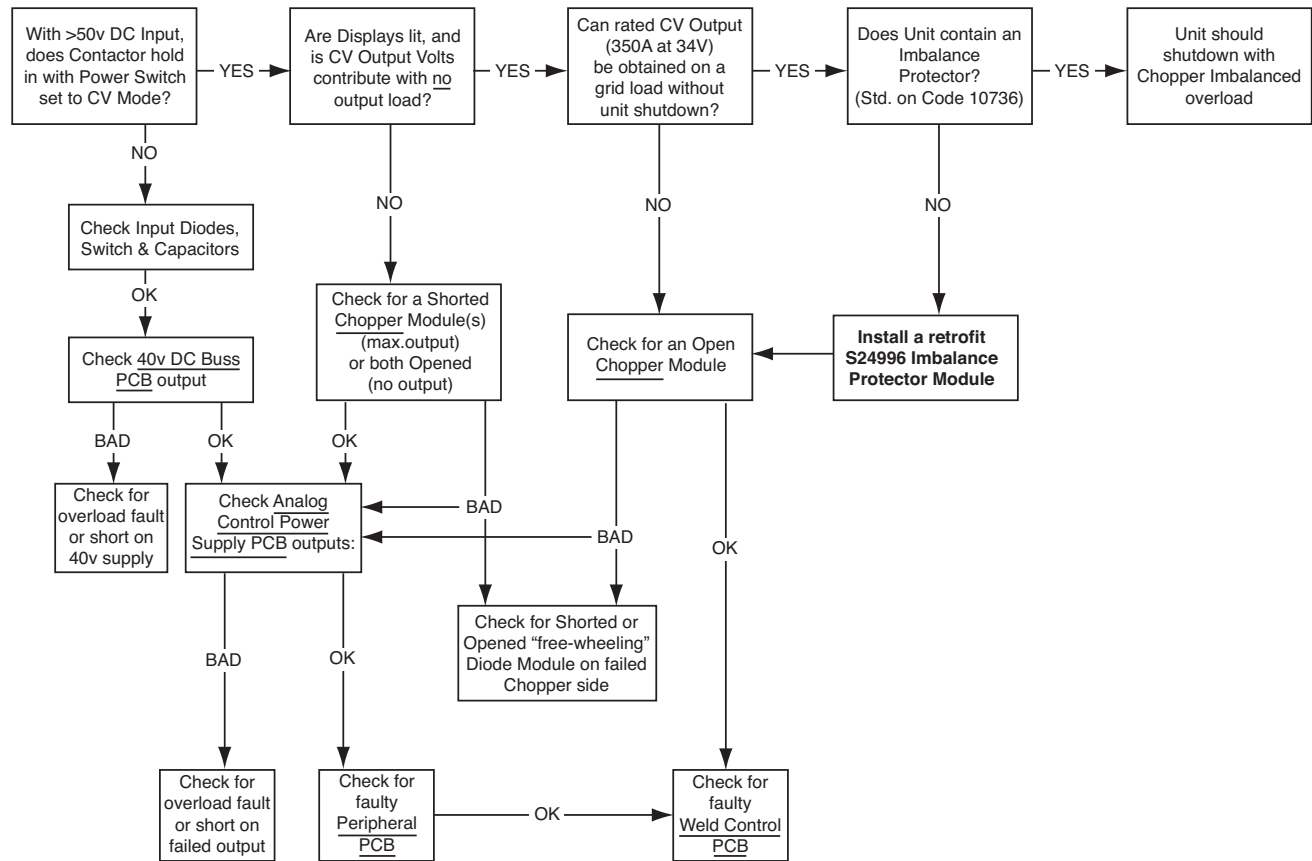

Return to Section TOC
Return to Master TOC

INPUT CONTACTOR COIL RESISTANCE AND SUPPLY VOLTAGE TEST



WARNING

Service and repair should be performed by only Lincoln Electric factory trained personnel. Unauthorized repairs performed on this equipment may result in danger to the technician or machine operator and will invalidate your factory warranty. For your safety and to avoid electrical shock, please observe all safety notes and precautions detailed throughout this manual.

If for any reason you do not understand the test procedures or are unable to perform the test/repairs safely, contact the Lincoln Electric Service Department for electrical troubleshooting assistance before you proceed. Call 1-888-935-3877.

TEST DESCRIPTION

This test will determine if the Input Contactor is functioning properly.

MATERIALS NEEDED

- Volt/Ohmmeter
- 3/8" Nut driver
- Needle nose pliers
- Wiring Diagram
- External, isolated 40 VDC power supply

This procedure should take approximately 40 minutes to perform.

MULTI-WELD® 350



INPUT CONTACTOR COIL RESISTANCE AND SUPPLY VOLTAGE TEST (CONTINUED)

FIGURE F.3 – INPUT CONTACTOR DETAILS

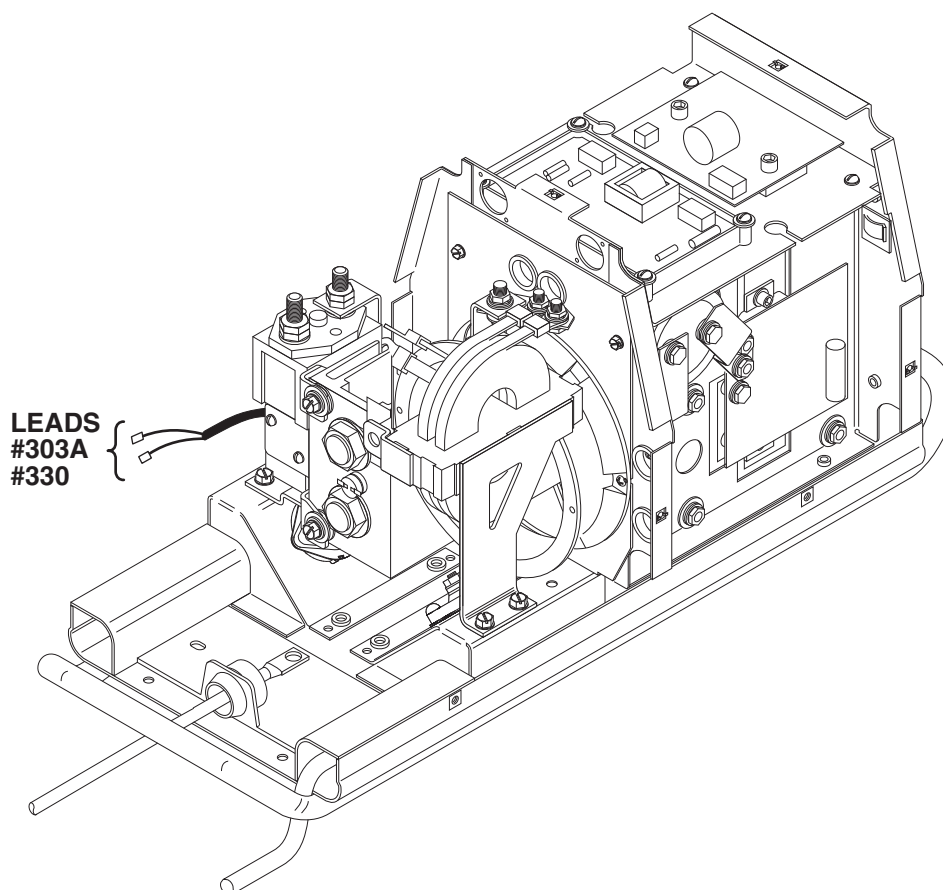

COIL TEST PROCEDURE

1. Set the CC/CV power switch to OFF.
2. Remove input power to the machine.
3. Perform the **Case Cover Removal Procedure**.
4. Perform the **Power Module Capacitor Discharge Procedure**.
5. Locate the input contactor and coil leads #303A and #330. See Figure F.3.
6. Label and disconnect leads #303A and #330 at their in-line connectors.
7. Check the coil resistance. Normal coil resistance is approximately 100 ohms. If the coil resistance is abnormally high or low, the contactor may be faulty. Replace the contactor.
8. Reconnect leads #303A and #330 to the coil leads.



WARNING

ELECTRIC SHOCK can kill.

Disconnect input power before removing the case cover and performing tests or making repairs to the machine.

INPUT CONTACTOR COIL RESISTANCE AND SUPPLY VOLTAGE TEST (*CONTINUED*)



WARNING

ELECTRIC SHOCK can kill.

With the input power ON, there are high voltages inside the machine. Do not reach into the machine or touch any internal part of the machine while power is on.

9. Carefully apply the correct input power to the MULTI-WELD® 350 (50 – 113 VDC).
 10. Set the MULTI-WELD® 350 to either CC or CV mode. The contactor should activate. If it does not, increase the input voltage but do not exceed 113 VDC.
 11. Carefully check for approximately 40 VDC at leads #303A to #330. If the 40 VDC is applied to the coil leads, the contactor should activate.
 12. If the reading is less than 40 VDC or not present, perform the **DC Buss Power Supply PC Board Test**.
 13. Also check leads #303A, #330, #303, #403, #230 and their associated plugs for loose or faulty connections. See the Wiring Diagram.
4. Label and disconnect leads #303A and #330 at their in-line connectors.
 5. Using the external, isolated 40 VDC power supply, carefully apply 40 VDC to the coil leads. The contactor should activate.
 6. With the contactor activated, check the continuity across the large contacts. (Zero ohms or very low resistance is normal.) See **Figure F.3**. If the resistance is high, the input contactor is faulty. Replace the input contactor.
 7. When the contactor is not activated, the resistance should be infinite or very high across the contacts. If the resistance is low, the input contactor is faulty. Replace the input contactor.
 8. Remove the 40 VDC external supply and reconnect the coil leads previously removed.
 9. If finished testing, perform the **Case Cover Replacement Procedure**.

TEST FOR CONTACT CONTINUITY

1. Disconnect input power to the MULTI-WELD® 350.



WARNING

ELECTRIC SHOCK can kill.

Disconnect input power before removing the case cover and performing tests or making repairs to the machine.

2. Perform the **Power Module Capacitor Discharge Procedure**.
3. Locate the input contactor and coil leads #303A and #330. See **Figure F.3**.

MULTI-WELD® 350



ANALOG CONTROL POWER SUPPLY PC BOARD TEST



WARNING

Service and repair should be performed by only Lincoln Electric factory trained personnel. Unauthorized repairs performed on this equipment may result in danger to the technician or machine operator and will invalidate your factory warranty. For your safety and to avoid electrical shock, please observe all safety notes and precautions detailed throughout this manual.

If for any reason you do not understand the test procedures or are unable to perform the test/repairs safely, contact the Lincoln Electric Service Department for electrical troubleshooting assistance before you proceed. Call 1-888-935-3877.

TEST DESCRIPTION

This test will determine if the Analog Control Power Supply PC Board is receiving and passing the proper signal voltages.

MATERIALS NEEDED

3/8" Nut driver
Analog Volt/Ohmmeter
Wiring Diagram

This procedure should take approximately 30 minutes to perform.

ANALOG CONTROL POWER SUPPLY PC BOARD TEST (CONTINUED)

FIGURE F.4 – ANALOG CONTROL POWER SUPPLY PC BOARD

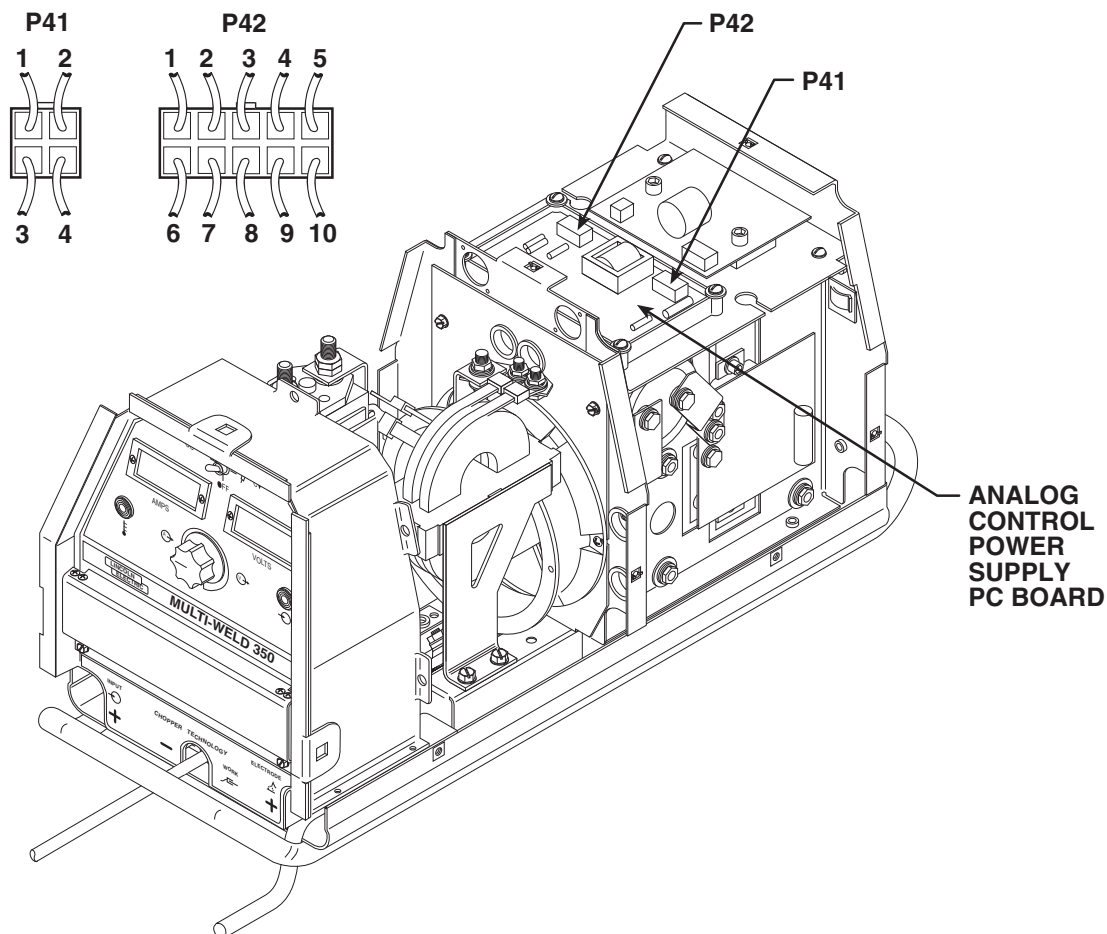

TEST PROCEDURE

1. Set the CC/CV power switch to OFF.
2. Remove input power to the machine.
3. Perform the **Case Cover Removal Procedure**.
4. Perform the **Power Module Capacitor Discharge Procedure**.
5. Locate the Analog Control Power Supply PC Board and plugs P41 and P42. See Figure F.4.
6. Carefully apply the correct input power to the MULTI-WELD® 350 (50 – 113 VDC).
7. Set the MULTI-WELD® 350 to either CC or CV mode. Make sure the input contactor activates. If it does not, increase the input voltage but do not exceed 113 VDC. The LED on the DC Buss Power Supply PC Board should light.
8. Check the Analog Control Power Supply PC Board input and output voltages according to **Table F.1**. See Figure F.4 and the Wiring Diagram.

**WARNING****ELECTRIC SHOCK can kill.**

Disconnect input power before removing the case cover and performing tests or making repairs to the machine.

MULTI-WELD® 350

ANALOG CONTROL POWER SUPPLY PC BOARD TEST (CONTINUED)

9. If all the voltages are correct, the Analog Control Power Supply PC Board is operating properly.
10. If any of the output voltages are not correct and the input voltage is correct, the Analog Control Power Supply PC Board may be faulty.
11. If the input voltage is not correct, check leads #436, #437 and their associated plugs for loose or faulty connections. See the Wiring Diagram. Perform the **DC Buss Power Supply PC Board Test**.

TABLE F.1
ANALOG CONTROL POWER SUPPLY PC BOARD VOLTAGE TABLE

Positive Meter Probe Test Point	Negative Meter Probe Test Point	Acceptable Voltage Reading	Conditions/Comments
Plug P41 – Pin 1	Plug P41 – Pin 2	38.0 – 42.0 VDC	Supply from DC Buss Power Supply Board
Plug P42 – Pin 1	Plug P42 – Pin 6	18.0 – 21.0 VDC	Supply for right side Chopper PC Board
Plug P42 – Pin 3	Plug P42 – Pin 8	18.0 – 21.0 VDC	Supply for left side Chopper PC Board
Plug P42 – Pin 10	Plug P42 – Pin 4	14.0 – 16.0 VDC	+15 VDC Supply to Peripheral Board
Plug P42 – Pin 5	Plug P42 – Pin 7	14.0 – 16.0 VDC	+15 VDC Supply to Weld Control Board
Plug P42 – Pin 2	Plug P42 – Pin 7	4.5 – 5.5 VDC	+5 VDC Supply to Weld Control Board
Plug P42 – Pin 9	Plug P42 – Pin 7	-14.0 – 16.0 VDC	-15 VDC Supply to Weld Control Board

12. If finished testing, perform the **Case Cover Replacement Procedure**.

DC BUSS POWER SUPPLY PC BOARD TEST



WARNING

Service and repair should be performed by only Lincoln Electric factory trained personnel. Unauthorized repairs performed on this equipment may result in danger to the technician or machine operator and will invalidate your factory warranty. For your safety and to avoid electrical shock, please observe all safety notes and precautions detailed throughout this manual.

If for any reason you do not understand the test procedures or are unable to perform the test/repairs safely, contact the Lincoln Electric Service Department for electrical troubleshooting assistance before you proceed. Call 1-888-935-3877.

TEST DESCRIPTION

This test will determine if the DC Buss Power Supply PC Board is receiving and processing the proper signal voltages.

MATERIALS NEEDED

- 3/8" Nut driver
- Analog Volt/Ohmmeter
- Wiring Diagram

This procedure should take approximately 30 minutes to perform.

DC BUSS POWER SUPPLY PC BOARD TEST (CONTINUED)

FIGURE F.5 – DC BUSS POWER SUPPLY PC BOARD

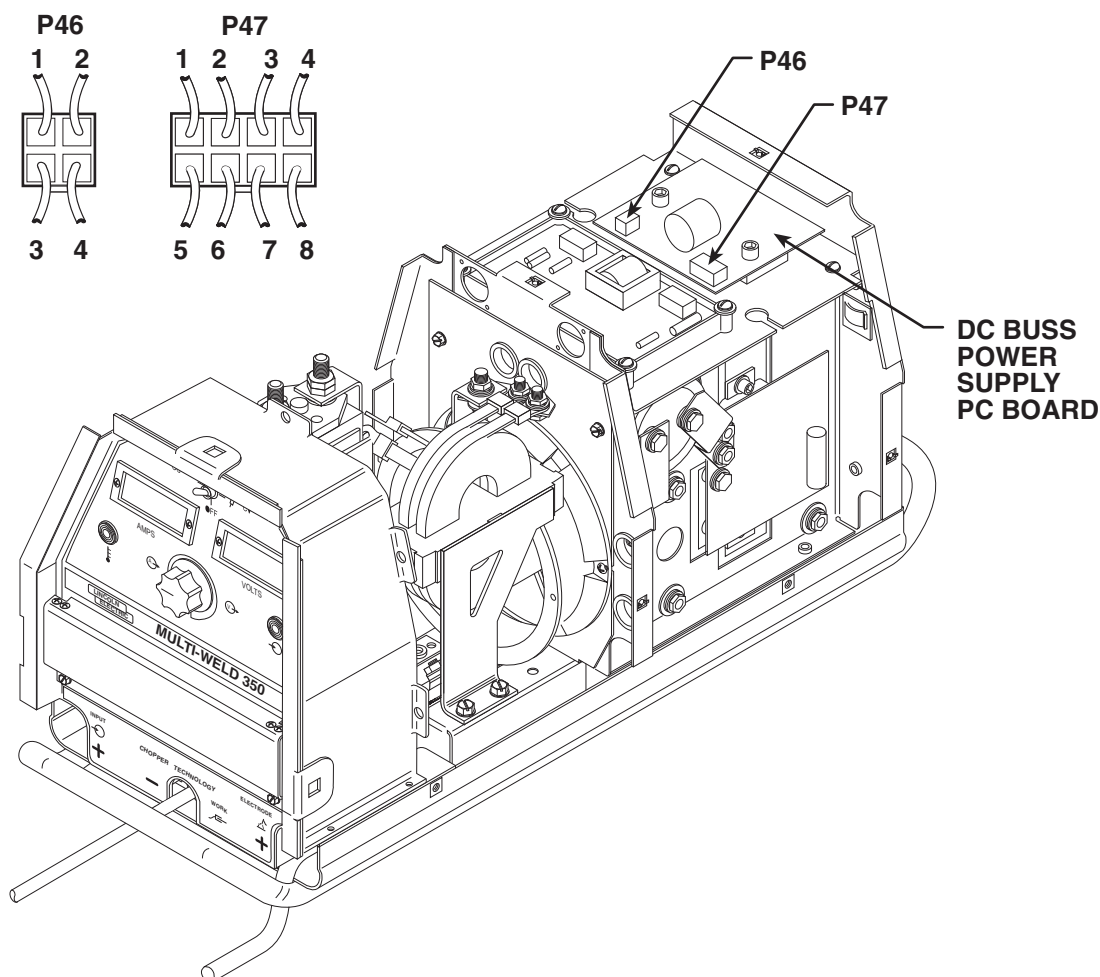

TEST PROCEDURE

1. Set the CC/CV power switch to OFF.
2. Remove input power to the machine.

**WARNING****ELECTRIC SHOCK can kill.**

Disconnect input power before removing the case cover and performing tests or making repairs to the machine.

3. Perform the **Case Cover Removal Procedure**.

4. Perform the **Power Module Capacitor Discharge Procedure**.
5. Locate the DC Buss Power Supply PC Board and plugs P46 and P47. See Figure F.5.
6. Carefully apply the correct input power to the MULTI-WELD® 350 (50 – 113 VDC).
7. Set the MULTI-WELD® 350 to either CC or CV mode. Make sure the input contactor activates. If it does not, increase the input voltage but do not exceed 113 VDC. The LED on the DC Buss Power Supply PC Board should light.

MULTI-WELD® 350



DC BUSS POWER SUPPLY PC BOARD TEST (CONTINUED)

8. Check the DC Buss Power Supply PC Board input and output voltages according to Table F.2. See **Figure F.5** and the Wiring Diagram.
9. If all the voltages are correct, the DC Buss Power Supply PC Board is operating properly.
10. If any of the output voltages are not correct and the input voltage is correct, the DC Buss Supply Board may be faulty.
11. If the input voltage is not correct, check leads #401A, #402, #302, #202, #231 and the On/Off mode switch (SW1). See the Wiring Diagram.

NOTE: The input voltage to the DC Buss Power Supply PC Board should be the same as the input voltage applied to the MULTI-WELD® 350.

TABLE F.2
DC BUSS POWER SUPPLY PC BOARD VOLTAGE TABLE

Positive Meter Probe Test Point	Negative Meter Probe Test Point	Acceptable Voltage Reading	Conditions/Comments
Plug P46 – Pin 1	Plug P46 – Pin 3	50 – 113 VDC	Should be same as input voltage supplied to MULTI-WELD® 350
Plug P47 – Pin 7	Plug P47 – Pin 1	38.0 – 42.0 VDC	Supply to Analog Control Power Supply PC Board
Plug P47 – Pin 8	Plug P47 – Pin 6	38.0 – 42.0 VDC	Supply for Fan and Input Contactor
Plug P47 – Pin 4	Plug P47 – Pin 6	38.0 – 42.0 VDC	Output to Peripheral Board

12. If finished testing, perform the **Case Cover Replacement Procedure**.

CHOPPER PC BOARD INPUT VOLTAGES AND RESISTANCE TEST



WARNING

Service and repair should be performed by only Lincoln Electric factory trained personnel. Unauthorized repairs performed on this equipment may result in danger to the technician or machine operator and will invalidate your factory warranty. For your safety and to avoid electrical shock, please observe all safety notes and precautions detailed throughout this manual.

If for any reason you do not understand the test procedures or are unable to perform the test/repairs safely, contact the Lincoln Electric Service Department for electrical troubleshooting assistance before you proceed. Call 1-888-935-3877.

TEST DESCRIPTION

This test will determine if there are shorted IGBTs or Chopper PC Boards. This test will also verify that the Chopper PC Boards are receiving the correct operating voltages.

MATERIALS NEEDED

- Volt/Ohmmeter
- 3/8"Nut driver
- 7/16" Wrench
- Wiring Diagram

This procedure should take approximately 50 minutes to perform.

CHOPPER PC BOARD INPUT VOLTAGES AND RESISTANCE TEST (CONTINUED)

PROCEDURE

1. With all input power and the wrap-around cover removed from the unit, make sure the input capacitors (C1&C2) are discharged by touching a 250hm/25W resistor across the terminal screws.
2. On each side (left or right) to be checked; open the following connections:
 - a. Remove the (+) capacitor terminal screw and isolate both the copper (+) strap and the X1 lead from the connection.
 - b. Remove the (-) capacitor terminal screw and isolate both the copper (-) strap and X4 lead from the connection. (Include #401 leads on the left side).
 - c. Remove the Reverse Diode (D5 or D6) lead from under the nut on the Chopper PCB strap.
3. Using an ohm-meter set for about 100K-ohm range, continuity check the following:

Power Component:	Meter (+) Probe to:	Meter (-) Probe to:	Proper Reading:	Problem If Reading Not Proper:
Input Diodes (D1 and D2)	(+) Input stud	Diode leads	Conducts	Opened Diodes
	Diode leads	(+) Input stud	Blocks	Shorted Diodes(s)
Capacitor (C1 or C2)	(+) Terminal	(-) Terminal	Increases with Time	0 ohm = Shorted Cap. High ohms = Open Cap.
Chopper IGBT (Chopper PCB's)	Heat Sink*	(+) Strap	Conducts	Opened IGBT
	(+) Strap	Heat Sink*	Blocks	Shorted IGBT
Reverse Diode (D5 or D6)	Heat Sink*	Diode Lead	Conducts	Opened Diode
	Diode lead	Heat Sink*	Blocks	Shorted Diode
Free-Wheeling Diode (D3 or D4)	Heat Sink*	(-) Strap	Blocks	Shorted Diode
	(-) Strap	Heat Sink*	Conducts	Opened Diode

4. Replace any failed component(s), then reconnect removed leads (per above).

CHOPPER PC BOARD INPUT VOLTAGES AND RESISTANCE TEST (CONTINUED)

FIGURE F.6 – POWER MODULE ASSEMBLY DETAILS

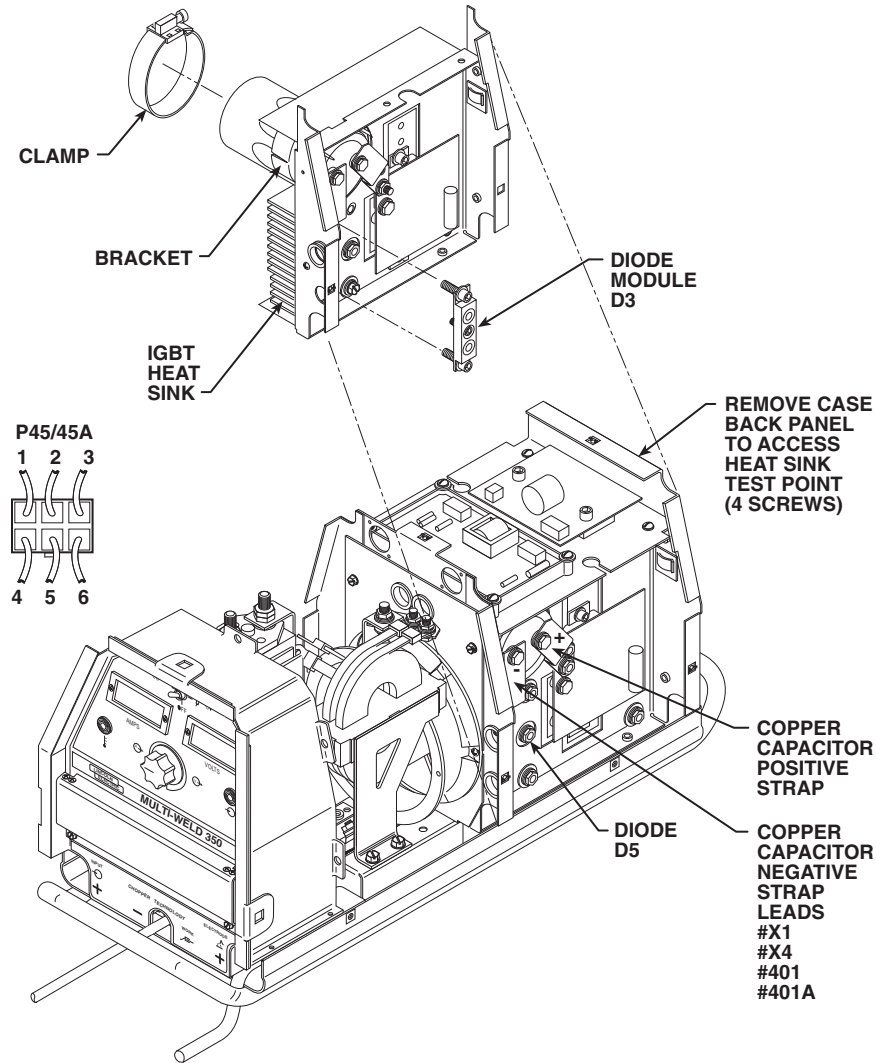

TEST PROCEDURE

1. Set the CC/CV power switch to OFF.
2. Remove input power to the machine.
3. Perform the *Case Cover Removal Procedure*.
4. Perform the *Power Module Capacitor Discharge Procedure*.

⚠ WARNING

ELECTRIC SHOCK can kill.

Disconnect input power before removing the case cover and performing tests or making repairs to the machine.

MULTI-WELD® 350



Return to Section TOC
 Return to Section TOC
 Return to Section TOC
 Return to Section TOC
 Return to Master TOC
 Return to Master TOC
 Return to Section TOC
 Return to Section TOC
 Return to Master TOC
 Return to Master TOC

CHOPPER PC BOARD INPUT VOLTAGES AND RESISTANCE TEST (CONTINUED)

Test Procedure for the Left Side Power Module

1. Locate the Power Module Capacitor terminals. Using the 7/16" wrench, disconnect leads #X1, #X4, #401, #401A and the copper straps. Carefully electrically isolate these leads and straps from the capacitor terminals and heat sink assembly. See **Figure F.6**.
2. Using the 3/8" nut driver, remove the four screws holding the case back to the tunnel assembly. This will provide access to the IGBT heat sinks.
3. Using the analog ohmmeter, connect the positive meter probe to the positive copper strap and the negative meter probe to the IGBT heat sink. (This is the inner heat sink.) See **Figure F.6** for test point locations. The resistance should be very high (over 20,000 ohms). If the resistance is low, then either the IGBT is shorted or the diode D5 is shorted. Disconnect the small D5 cathode lead to isolate the problem. It is possible that both devices may be faulty.
4. Reverse the meter leads. The resistance should be low (approximately 100 ohms). If the resistance is high, the diode D5 may be open.
5. Using the analog ohmmeter, check diode module D3. Connect the negative meter probe to the negative copper strap connected to the diode module and the positive probe to the heat sink. See **Figure F.6** for the test point locations. The resistance should be very high (over 20,000 ohms). If the resistance is low, the diode module D3 may be shorted.
6. Reverse the meter leads. The resistance should be low (approximately 100 ohms). If the resistance is high, the diode module D3 may be open.
7. Repeat Steps 1 through 5 for the **Right Side Power Module**. See the Wiring Diagram.
8. Replace all leads previously removed. See **Figure F.6** and the Wiring Diagram. Torque the capacitor bolts to 50 to 60 inch pounds.

CHOPPER PC BOARD VOLTAGE TESTS FOR BOTH LEFT AND RIGHT SIDES

1. Locate Plug P45(A) and disconnect it from J45(A). See **Figure F.6**.



WARNING

ELECTRIC SHOCK can kill.

With the input power ON, there are high voltages inside the machine. Do not reach into the machine or touch any internal part of the machine while power is on.

2. Carefully apply the correct input voltage to the MULTI-WELD® 350 (50 – 113 VDC). The machine should be in the CC mode and the CC Slope switch should be in the Stick/Gouge position.
3. Turn the machine on and carefully check for 18.0 – 21.0 VDC at P45(A) pin 1 (+) to P45(A) pin 3 (-). This is the 20 VDC supply from the Analog Control Power Supply PC Board to the Chopper PC Board.

NOTE: Be careful not to touch the capacitor terminals.

4. Also carefully check for 11.0 – 14.0 VDC at P45(A) pin 7 (+) to P45(A) pin 9 (-). This is the Pulse Width Modulation Signal from the Weld Control Board to the Chopper PC board.
5. If any of the voltages are not present, check associated leads and plugs for loose or faulty connections. See the Wiring Diagram.
6. Remove the input power and perform the **Power Module Capacitor Discharge Procedure**.
7. Reconnect the plugs previously disconnected.
8. If finished testing, perform the **Case Cover Replacement Procedure**.

TROUBLESHOOTING & REPAIR

NORMAL OPEN CIRCUIT VOLTAGE WAVEFORM

CC MODE – INPUT VOLTAGE APPLIED 75 VDC

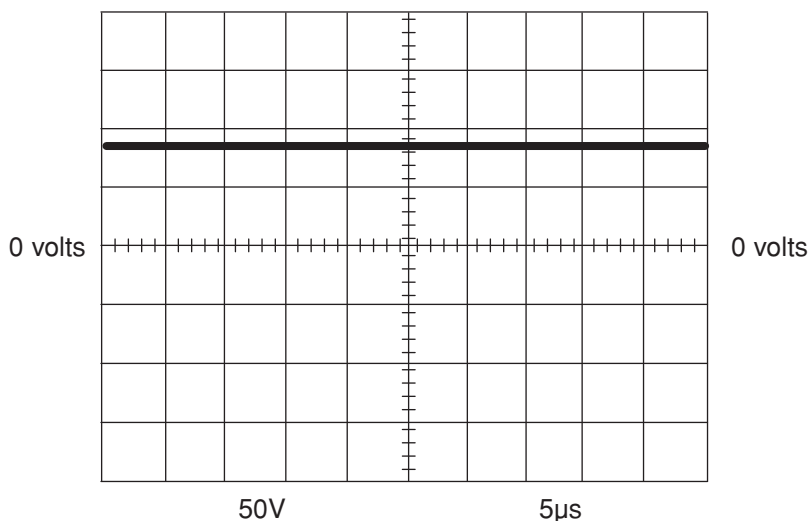

This is the typical CC open circuit output voltage generated from a properly operating machine. Note that each vertical division represents 50 volts and that each horizontal division represents 5 µs in time.

SCOPE SETTINGS

Volts/Div	50V/Div.
Horizontal Sweep	5 µs/Div.
Coupling	DC
Trigger	Internal

MULTI-WELD® 350



Return to Section TOC

Return to Section TOC

Return to Section TOC

Return to Section TOC

Return to Master TOC

Return to Master TOC

Return to Master TOC

Return to Master TOC

TROUBLESHOOTING & REPAIR

NORMAL OPEN CIRCUIT VOLTAGE WAVEFORM CV MODE – OUTPUT CONTROL AT MAXIMUM

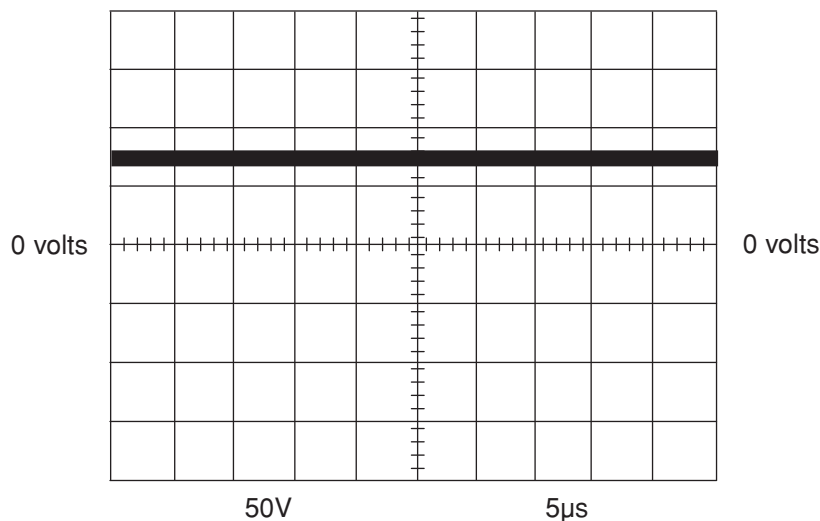

This is the typical CV output voltage generated from a properly operating machine. Note that each vertical division represents 50 volts and that each horizontal division represents 5 µs in time.

SCOPE SETTINGS

Volts/Div	50V/Div.
Horizontal Sweep	5 µs/Div.
Coupling	DC
Trigger	Internal

Return to Section TOC
Return to Master TOC

TROUBLESHOOTING & REPAIR

NORMAL WELD VOLTAGE WAVEFORM

MACHINE LOADED TO 350 AMPS AT 34 VOLTS – CC-STICK MODE

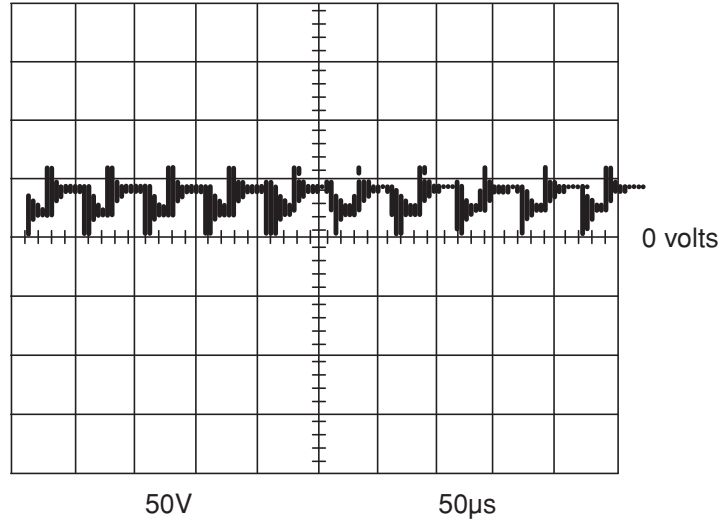

This is the typical CC output voltage generated from a properly operating machine. Note that each vertical division represents 50 volts and that each horizontal division represents 50µs in time.

The machine was loaded with a resistance grid bank to 350 amps at 34 volts.

SCOPE SETTINGS

Volts/Div	50V/Div.
Horizontal Sweep	50µs/Div.
Coupling	DC
Trigger	Internal

MULTI-WELD® 350



Return to Section TOC

Return to Section TOC

Return to Section TOC

Return to Section TOC

Return to Master TOC

Return to Master TOC

Return to Master TOC

Return to Master TOC

TROUBLESHOOTING & REPAIR

NORMAL WELD VOLTAGE WAVEFORM MACHINE LOADED TO 350 AMPS AT 34 VOLTS – CV MODE

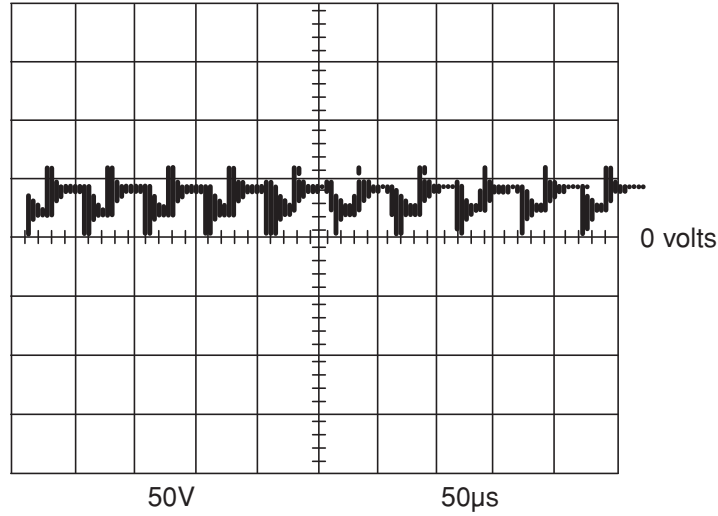

This is the typical CV output voltage generated from a properly operating machine. Note that each vertical division represents 50 volts and that each horizontal division represents 50µs in time.

The machine was loaded with a resistance grid bank to 350 amps at 34 volts.

SCOPE SETTINGS

Volts/Div	50V/Div.
Horizontal Sweep	50µs/Div.
Coupling	DC
Trigger	Internal

TROUBLESHOOTING & REPAIR

NORMAL OPEN CIRCUIT VOLTAGE WAVEFORM CV MODE – OUTPUT CONTROL AT MINIMUM

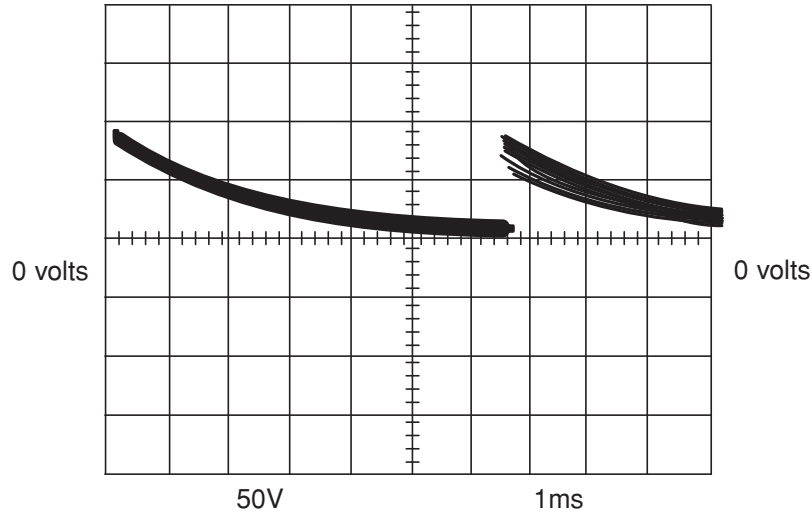

This is the typical CV open circuit output voltage generated from a properly operating machine. Note that each vertical division represents 50 volts and that each horizontal division represents 1 millisecond in time.

SCOPE SETTINGS

Volts/Div	50V/Div.
Horizontal Sweep	1 ms/Div.
Coupling	DC
Trigger	Internal

MULTI-WELD® 350



Return to Section TOC
Return to Section TOC
Return to Section TOC
Return to Section TOC
Return to Section TOC
Return to Section TOC

Return to Master TOC
Return to Master TOC
Return to Master TOC
Return to Master TOC
Return to Master TOC
Return to Master TOC

CASE FRONT ASSEMBLY REMOVAL AND REPLACEMENT



WARNING

Service and repair should be performed by only Lincoln Electric factory trained personnel. Unauthorized repairs performed on this equipment may result in danger to the technician or machine operator and will invalidate your factory warranty. For your safety and to avoid electrical shock, please observe all safety notes and precautions detailed throughout this manual.

If for any reason you do not understand the test procedures or are unable to perform the test/repairs safely, contact the Lincoln Electric Service Department for electrical troubleshooting assistance before you proceed. Call 1-888-935-3877.

DESCRIPTION

The following procedure will aid the technician in removing and replacing the Case Front Assembly on the MULTI-WELD® 350.

MATERIALS NEEDED

3/8" Nut driver, wrench or socket wrench
Wiring Diagram

This procedure should take approximately 15 minutes to perform.

MULTI-WELD® 350



CASE FRONT ASSEMBLY REMOVAL AND REPLACEMENT (CONTINUED)

FIGURE F.7 – CASE FRONT ASSEMBLY REMOVAL

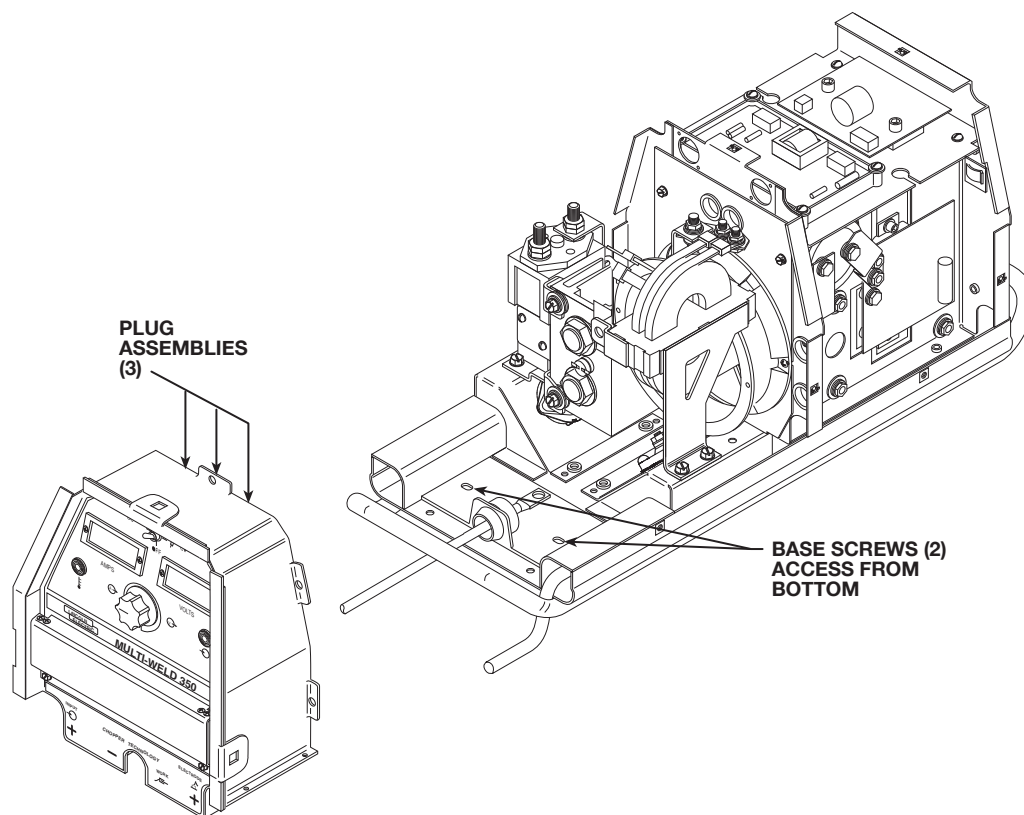

REMOVAL PROCEDURE

1. Set the CC/CV power switch to OFF.
2. Remove input power to the machine.



WARNING

ELECTRIC SHOCK can kill.

Disconnect input power before removing the case cover and performing tests or making repairs to the machine.

3. Perform the **Case Cover Assembly Removal Procedure**.
4. Perform the **Power Module Capacitor Discharge Procedure**.
5. Label and disconnect the three wiring harness plug assemblies that connect to the case front assembly. See Figure F.7 and the Wiring Diagram.

6. Carefully turn the machine onto its side. See Figure F.7 for location.
7. Using the 3/8" nut driver, remove the two screws holding the case front assembly to the machine base. Support the case front assembly as you remove the second screw.
8. Carefully remove the case front assembly and set the machine back upright.

REPLACEMENT PROCEDURE

1. Carefully turn the machine onto its side.
2. Position the case front assembly on the base and attach it with two screws previously removed.
3. Set the machine back upright. Connect the three wiring harness plug assemblies.
4. Replace the case cover.

MULTI-WELD® 350



WELD CONTROL OR PERIPHERAL PC BOARD REMOVAL AND REPLACEMENT



WARNING

Service and repair should be performed by only Lincoln Electric factory trained personnel. Unauthorized repairs performed on this equipment may result in danger to the technician or machine operator and will invalidate your factory warranty. For your safety and to avoid electrical shock, please observe all safety notes and precautions detailed throughout this manual.

If for any reason you do not understand the test procedures or are unable to perform the test/repairs safely, contact the Lincoln Electric Service Department for electrical troubleshooting assistance before you proceed. Call 1-888-935-3877.

DESCRIPTION

The following procedure will aid the technician in removing and replacing the Weld Control or Peripheral PC Board on the MULTI-WELD® 350.

MATERIALS NEEDED

3/8" Nut driver, wrench or socket wrench
5/16" Nut driver
Wiring Diagram

This procedure should take approximately 30 minutes to perform.

MULTI-WELD® 350



WELD CONTROL OR PERIPHERAL PC BOARD REMOVAL AND REPLACEMENT (CONTINUED)

FIGURE F.8 – CASE FRONT ASSEMBLY DETAILS

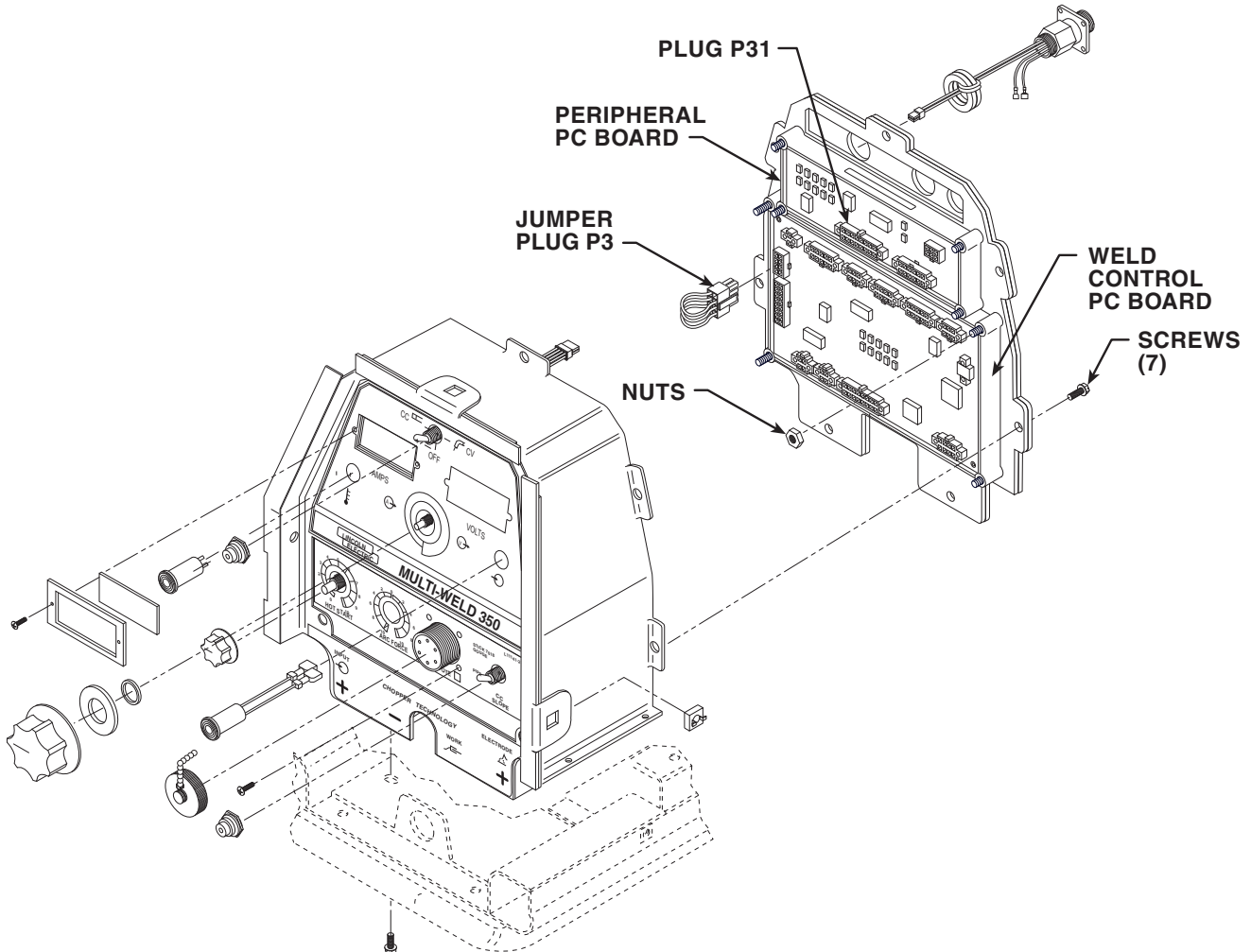

REMOVAL PROCEDURE

Refer to Figure F.8.

1. Set the CC/CV power switch to OFF.
2. Remove input power to the machine.



WARNING

ELECTRIC SHOCK can kill.

Disconnect input power before removing the case cover and performing tests or making repairs to the machine.

3. Perform the **Case Cover Assembly Removal Procedure**.
4. Perform the **Power Module Capacitor Discharge Procedure**.
5. Perform the **Case Front Assembly Removal Procedure**.
6. Using the 5/16" nut driver, remove the seven screws from the control box rear panel.

MULTI-WELD® 350



WELD CONTROL OR PERIPHERAL PC BOARD REMOVAL AND REPLACEMENT (CONTINUED)

7. Carefully label and remove the 12 molex plugs from the Weld Control PC board. Press and hold the keeper on each plug as you remove it. Also remove plug P31 from the Peripheral PC Board as shown in **Figure F.8**. This will allow the assembly to lie flat.
8. Using the 3/8" nut driver, remove the four nuts holding the Weld Control PC Board in place.

NOTE: Verify the orientation of the Weld Control PC Board for replacement. You may need to remove a nut on the Peripheral PC Board in order to free the Weld Control PC Board.

9. Carefully remove the Weld Control PC Board.

NOTE: It may be necessary to pry gently on the PC Board to remove it.

REPLACEMENT PROCEDURE

1. Set the Weld Control PC Board squarely onto the studs and press it in place. Verify proper orientation. Replace any nuts removed from the Peripheral PC Board at disassembly.
2. Tighten the four 3/8" nuts holding the board in place.
3. Attach the molex plugs, including the plug removed from the Peripheral PC Board at disassembly. See the Wiring Diagram.

NOTE: Make sure jumper plug P3 is in place.

4. Attach the rear panel with seven 5/16" screws.
5. Perform the **Case Front Assembly Replacement Procedure**.
6. Perform the **Case Cover Assembly Replacement Procedure**.

AMPS/VOLTS DIGITAL METER AND POTENTIOMETER REMOVAL AND REPLACEMENT



WARNING

Service and repair should be performed by only Lincoln Electric factory trained personnel. Unauthorized repairs performed on this equipment may result in danger to the technician or machine operator and will invalidate your factory warranty. For your safety and to avoid electrical shock, please observe all safety notes and precautions detailed throughout this manual.

If for any reason you do not understand the test procedures or are unable to perform the test/repairs safely, contact the Lincoln Electric Service Department for electrical troubleshooting assistance before you proceed. Call 1-888-935-3877.

DESCRIPTION

The following procedure will aid the technician in removing and replacing the Amps or Volts Digital Meter or the Output Control Potentiometer on the MULTI-WELD® 350.

MATERIALS NEEDED

- 3/8" Nut driver, wrench or socket wrench
- 5/16" Nut driver
- Phillips screw driver
- Allen head wrench
- Diagonal cutters
- Wiring Diagram

This procedure should take approximately 30 minutes to perform.

MULTI-WELD® 350



AMPS/VOLTS DIGITAL METER AND POTENTIOMETER REMOVAL AND REPLACEMENT (CONTINUED)

FIGURE F.9 – DIGITAL METER AND POTENTIOMETER DETAILS

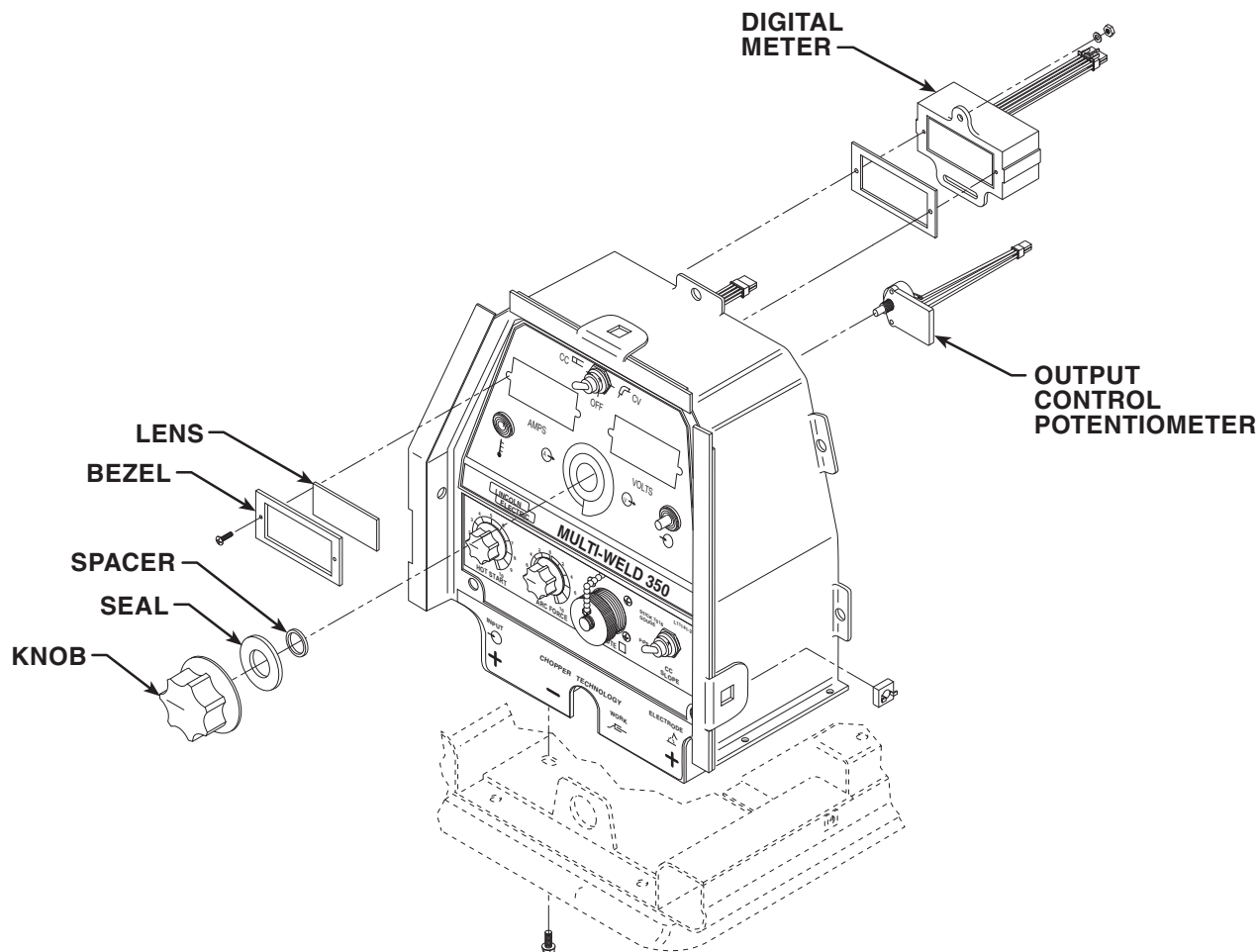

DIGITAL METER REMOVAL PROCEDURE

Refer to Figure F.9.

1. Set the CC/CV power switch to OFF.
2. Remove input power to the machine.



WARNING

ELECTRIC SHOCK can kill.

Disconnect input power before removing the case cover and performing tests or making repairs to the machine.

3. Perform the *Case Cover Assembly Removal Procedure*.
4. Perform the *Power Module Capacitor Discharge Procedure*.
5. Perform the *Case Front Assembly Removal Procedure*.
6. Using the 5/16" nut driver, remove the seven screws from the control box rear panel.

MULTI-WELD® 350

LINCOLN
ELECTRIC

AMPS/VOLTS DIGITAL METER AND POTENTIOMETER REMOVAL AND REPLACEMENT (CONTINUED)

7. Carefully remove the Amps or Volts Digital Meter molex plug from the Weld Control PC Board. Press and hold the keeper on the plug as you remove it.
8. Using the 5/16" nut driver, remove the two nuts and flat washers holding the Amps or Volts Digital Meter in place.
9. Using the phillips screw driver, remove the two screws holding the bezel and lens (and the meter) to the front panel.
10. Carefully remove the Amps or Volts Digital Meter. Do not damage the gasket.

REPLACEMENT PROCEDURE

1. Fit the meter into position, adjustable slot side down. Verify that the gasket is in place.
2. Insert the two phillips screws through the bezel, and with the lens in place, tighten the screws into the meter.
3. Install the flat washers and 5/16" nuts onto the screws and tighten them.
4. Attach the molex plug to the Weld Control PC Board. See the Wiring Diagram.
5. Attach the rear panel with seven 5/16" screws.
6. Perform the **Case Front Assembly Replacement Procedure**.
7. Perform the **Case Cover Assembly Replacement Procedure**.

OUTPUT CONTROL POTENTIOMETER REMOVAL PROCEDURE

Refer to **Figure F.9**.

1. Set the CC/CV power switch to OFF.
2. Remove input power to the machine.



WARNING

ELECTRIC SHOCK can kill.

Disconnect input power before removing the case cover and performing tests or making repairs to the machine.

3. Perform the **Case Cover Assembly Removal Procedure**.
4. Perform the **Power Module Capacitor Discharge Procedure**.
5. Perform the **Case Front Assembly Removal Procedure**.
6. Using the 5/16" nut driver, remove the seven screws from the control box rear panel.
7. Carefully remove the potentiometer molex plug from the Weld Control PC Board. Press and hold the keeper on the plug as you remove it.
8. Using the diagonal cutters, cut the cable tie holding the potentiometer to the back panel.
9. Using the allen wrench, remove the set screw holding the potentiometer knob to the shaft.
10. Remove the knob, shaft seal, and spacer. Pull the potentiometer out from the panel.

REPLACEMENT PROCEDURE

1. Fit the potentiometer into position, verifying proper orientation. Install a new cable tie.
2. Install the spacer, shaft seal, and knob.
3. Tighten the knob onto the shaft with the set screw.
4. Attach the molex plug to the Weld Control PC Board. See the Wiring Diagram.
5. Attach the rear panel with seven 5/16" screws.
6. Perform the **Case Front Assembly Replacement Procedure**.
7. Perform the **Case Cover Assembly Replacement Procedure**.

INPUT CONTACTOR REMOVAL AND REPLACEMENT



WARNING

Service and repair should be performed by only Lincoln Electric factory trained personnel. Unauthorized repairs performed on this equipment may result in danger to the technician or machine operator and will invalidate your factory warranty. For your safety and to avoid electrical shock, please observe all safety notes and precautions detailed throughout this manual.

If for any reason you do not understand the test procedures or are unable to perform the test/repairs safely, contact the Lincoln Electric Service Department for electrical troubleshooting assistance before you proceed. Call 1-888-935-3877.

DESCRIPTION

The following procedure will aid the technician in removing and replacing the Input Contactor on the MULTI-WELD® 350.

MATERIALS NEEDED

- 3/8" Nut driver, wrench or socket wrench
- 17 mm Wrench or socket wrench
- Diagonal cutters
- Wiring Diagram

This procedure should take approximately 30 minutes to perform.

MULTI-WELD® 350



INPUT CONTACTOR REMOVAL AND REPLACEMENT (*CONTINUED*)

FIGURE F.10 – INPUT CONTACTOR ASSEMBLY DETAILS

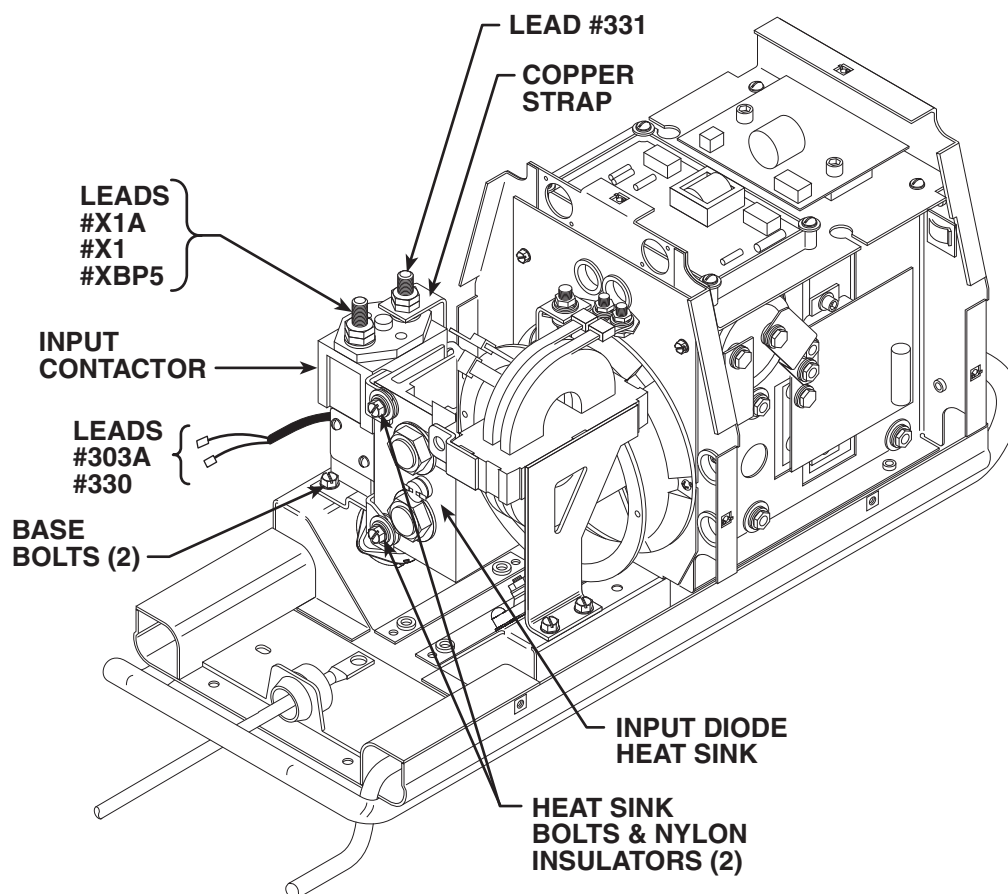
**REMOVAL PROCEDURE**

Refer to Figure F.10.

1. Set the CC/CV power switch to OFF.
2. Remove input power to the machine.

**WARNING**

ELECTRIC SHOCK can kill.

Disconnect input power before removing the case cover and performing tests or making repairs to the machine.

3. Perform the *Case Cover Assembly Removal Procedure*.
4. Perform the *Power Capacitor Discharge Procedure*.
5. Perform the *Case Front Assembly Removal Procedure*.
6. Label and disconnect leads #330 and #303A at their in-line connectors. Cut any necessary cable ties.

MULTI-WELD® 350



INPUT CONTACTOR REMOVAL AND REPLACEMENT (*CONTINUED*)

- Using the 17 mm wrench, remove the nuts from the input contactor terminal closest to the machine front. Label the leads and note their placement: bottom nut (not removed), lead #X1A, Lead #X1, lead #BP5.

NOTE: The top nut has grooves on the side that faces up.

- Using the 17 mm wrench, remove the nuts from the other input contactor terminal. Bottom nut (not removed), copper contactor strap, center nut, lead #331, top nut.

NOTE: The top nut has grooves on the side that faces up.

- With the 3/8" socket wrench, remove the two bolts and nylon insulators holding the input contactor to the input diode heat sink.

NOTE: The mylar insulation sheet fits between the nylon insulators at replacement.

- Using the 3/8" socket wrench, remove the two screws holding the input contactor to the machine base.
- Carefully remove the input contactor.

REPLACEMENT PROCEDURE

- Set the input contactor onto the machine base and install two 3/8" screws in the base mounting holes.
- Install the two sets of 3/8" bolts and nylon insulators, along with the mylar insulation sheet, to the input diode heat sink. The mylar sheet fits between the nylon insulators under the mounting bracket.
- Install the copper contactor strap and lead #331 to the input contactor rear terminal. See **Figure F.10**.
- Install leads #X1A, X1, and #BP5 to the input contactor front terminal. See **Figure F.10**. Be sure the top nut on each terminal is the grooved nut, with the grooves facing up.
- Connect leads #330 and #303A at their in-line connectors.
- Replace any cable ties cut at disassembly.
- Perform the **Case Front Assembly Replacement Procedure**.
- Perform the **Case Cover Assembly Replacement Procedure**.

INPUT DIODE REMOVAL AND REPLACEMENT



WARNING

Service and repair should be performed by only Lincoln Electric factory trained personnel. Unauthorized repairs performed on this equipment may result in danger to the technician or machine operator and will invalidate your factory warranty. For your safety and to avoid electrical shock, please observe all safety notes and precautions detailed throughout this manual.

If for any reason you do not understand the test procedures or are unable to perform the test/repairs safely, contact the Lincoln Electric Service Department for electrical troubleshooting assistance before you proceed. Call 1-888-935-3877.

DESCRIPTION

The following procedure will aid the technician in removing and replacing stud type Diodes on the aluminum heat sinks of the MULTI-WELD® 350.

MATERIALS NEEDED

- 3/8" Nut driver, wrench or socket wrench
- 1/2" socket wrench and extension
- 17 mm Wrench or socket wrench
- 1¼ " Open end wrench
- Penetrox A13 joint compound
- Loctite 271
- "Slip" type torque wrench
- No. 000 fine steel wool
- Diagonal cutters
- Wiring Diagram

This procedure should take approximately 45 minutes to perform.

MULTI-WELD® 350



INPUT DIODE REMOVAL AND REPLACEMENT (CONTINUED)

FIGURE F.11 – INPUT DIODE ASSEMBLY DETAILS

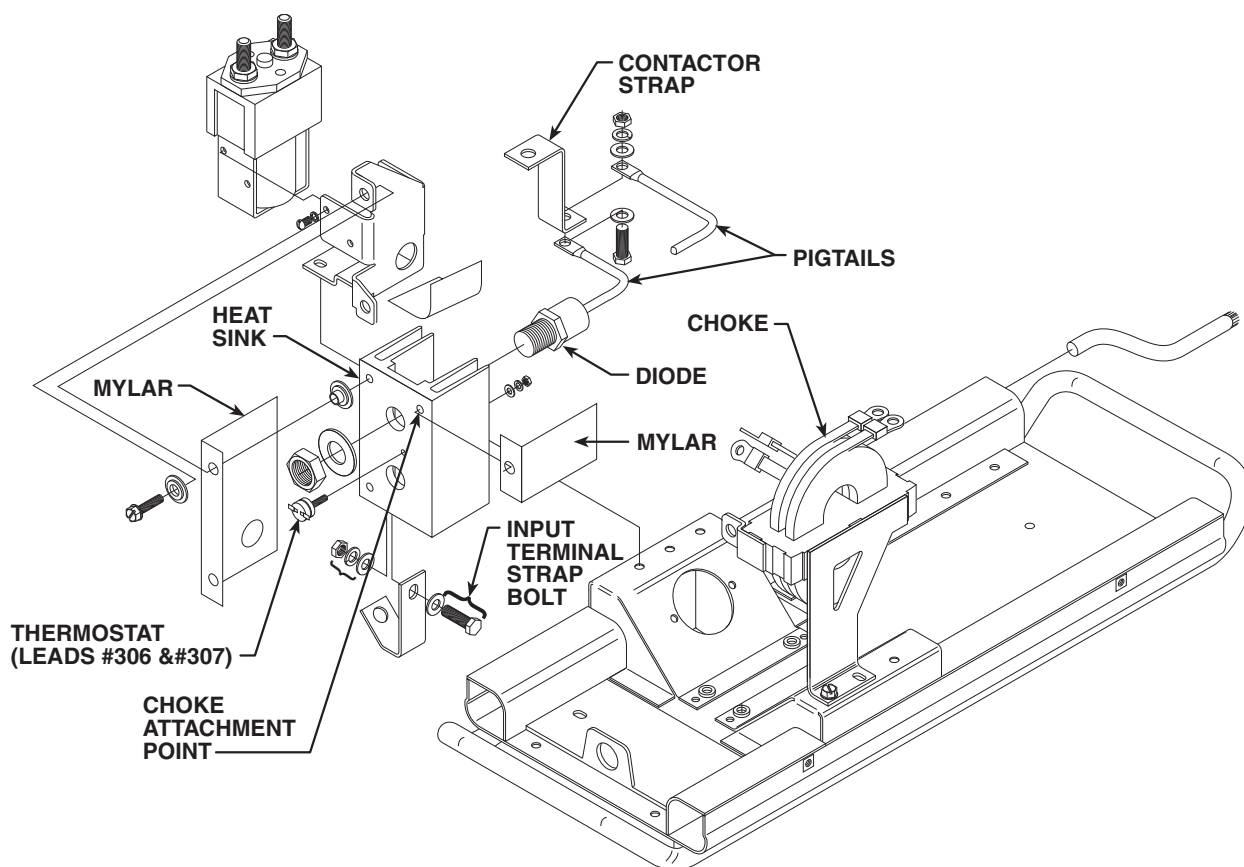

REMOVAL PROCEDURE

Refer to Figure F.11.

1. Set the CC/CV power switch to OFF.
2. Remove input power to the machine.



WARNING

ELECTRIC SHOCK can kill.

Disconnect input power before removing the case cover and performing tests or making repairs to the machine.

3. Perform the **Case Cover Assembly Removal Procedure**.
4. Perform the **Power Module Capacitor Discharge Procedure**.

5. Perform the **Case Front Assembly Removal Procedure**.
6. Perform the **Input Contactor Removal Procedure**.
7. Using the 3/8" socket wrench, remove the bolt, nylon insulators and mylar insulation sheet where the diode heat sink attaches to the choke. Note order for replacement.
8. Using the 1/2" socket wrench and extension, remove the nut, lock washer, flat washer, and bolt holding the heat sink to the input terminal strap. Note the flat washer under the bolt head.
9. Using the 1/2" wrench, remove the bolt and washers connecting the diode pig-tails to the contactor strap if this was not done during input contactor removal.

MULTI-WELD® 350

LINCOLN
ELECTRIC

INPUT DIODE REMOVAL AND REPLACEMENT (CONTINUED)

10. Disconnect thermostat leads #306 and #307.
11. Carefully remove the input diode assembly.
12. Using the 1/4" wrench, loosen the appropriate diode and remove the diode that is to be replaced.
13. Clean the area on the heat sink around the diode mounting surface using a putty knife or similar tool. **DO NOT SCRATCH THE DIODE MOUNTING SURFACE.**
14. Polish the heat sink's mounting surface to provide a bright, clean surface where the diode seats on the heat sink. Wipe the surface clean with a lint-free cloth or paper towel.
15. Inspect the mounting surfaces of each new diode. Remove all burrs and wipe clean. Do not use steel wool or any abrasive cleanser on the diode mounting surface.
16. Apply a thin (0.003" to 0.007") uniform layer of Penetrox A13 joint compound to the heat sink mounting surface.
17. Do not apply compound to the diode stud or mounting threads.
18. Apply two drops of Loctite 271 to the diode stud threads before tightening.

NOTE: The diode threads must be clean and free of defects so that it can be finger tightened before applying torque. A "slip" type torque wrench must be used to tighten the diode.

19. Tighten the diode to the specifications in the following table.

DIODE STUD SIZE	FOOT-POUNDS	INCH-POUNDS
3/4 - 16	25-27	300-324

REPLACEMENT PROCEDURE

Refer to *Figure F.11*.

1. Set the input diode assembly into the machine base. Connect the heat sink to the input terminal strap with the 1/2" bolt, washers, and nut. Note order – see removal procedures.
2. Install the heat sink to the choke, using the 3/8" bolt and nylon insulators, along with the mylar insulation sheet. The mylar sheet fits between the nylon insulators.
3. Connect thermostat leads #306 and #307. See the Wiring Diagram.
4. Perform the **Input Contactor Replacement Procedure**. Be sure to connect the input diode pig-tails to the contactor strap at the contactor rear terminal.
5. Replace any cable ties cut at disassembly.
6. Perform the **Case Front Assembly Replacement Procedure**.
7. Perform the **Case Cover Assembly Replacement Procedure**.

FAN MOTOR ASSEMBLY REMOVAL AND REPLACEMENT



WARNING

Service and repair should be performed by only Lincoln Electric factory trained personnel. Unauthorized repairs performed on this equipment may result in danger to the technician or machine operator and will invalidate your factory warranty. For your safety and to avoid electrical shock, please observe all safety notes and precautions detailed throughout this manual.

If for any reason you do not understand the test procedures or are unable to perform the test/repairs safely, contact the Lincoln Electric Service Department for electrical troubleshooting assistance before you proceed. Call 1-888-935-3877.

DESCRIPTION

The following procedure will aid the technician in removing and replacing the Cooling Fan and Motor of the MULTI-WELD® 350.

MATERIALS NEEDED

- 3/8" Nut driver, wrench or socket wrench
- 17 mm socket wrench and extension
- Phillips head screw driver
- Diagonal cutters

This procedure should take approximately 45 minutes to perform.

MULTI-WELD® 350



FAN MOTOR ASSEMBLY REMOVAL AND REPLACEMENT (CONTINUED)

FIGURE F.12 – FAN MOTOR ASSEMBLY DETAILS

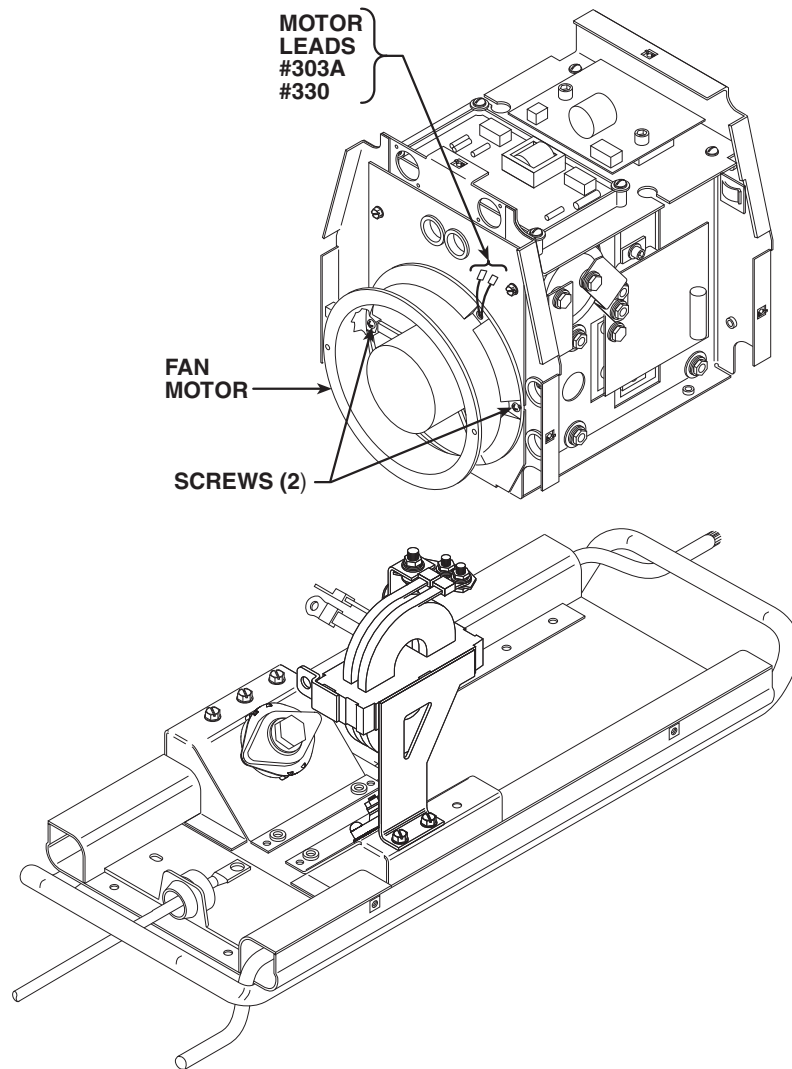

REMOVAL PROCEDURE

Refer to Figure F.12.

1. Set the CC/CV power switch to OFF.
2. Remove input power to the machine.



WARNING

ELECTRIC SHOCK can kill.

Disconnect input power before removing the case cover and performing tests or making repairs to the machine.

MULTI-WELD® 350

LINCOLN
ELECTRIC

FAN MOTOR ASSEMBLY REMOVAL AND REPLACEMENT (*CONTINUED*)

3. Perform the ***Input Diode Removal and Replacement Procedure***.
4. Disconnect the red motor lead from leads #303 and #303A and the blue motor lead from lead #300 at their in-line connectors. Cut any necessary cable ties.
5. Disconnect the two plug harness connections at the top of the tunnel assembly.
6. Using the phillips head screw driver, remove the two screws holding the fan motor housing to the tunnel assembly.
7. Carefully remove the fan motor assembly.

REPLACEMENT PROCEDURE

1. Set the fan motor assembly into the machine, against the tunnel assembly, with the motor nameplate label facing into the tunnel assembly.
2. Connect the red motor lead to leads #303 and #303A and the blue motor lead to lead #300 at their in-line connectors.
3. Mount the fan motor housing to the tunnel assembly with two phillips screws.
4. Connect the two plug harness connections at the top of the tunnel assembly.
5. Replace any cable ties previously removed.
6. Perform the ***Input Diode Removal and Replacement Procedure***.

POWER CAPACITOR REMOVAL AND REPLACEMENT



WARNING

Service and repair should be performed by only Lincoln Electric factory trained personnel. Unauthorized repairs performed on this equipment may result in danger to the technician or machine operator and will invalidate your factory warranty. For your safety and to avoid electrical shock, please observe all safety notes and precautions detailed throughout this manual.

If for any reason you do not understand the test procedures or are unable to perform the test/repairs safely, contact the Lincoln Electric Service Department for electrical troubleshooting assistance before you proceed. Call 1-888-935-3877.

DESCRIPTION

This procedure will aid the technician in the removal and replacement of the Power Capacitors on the MULTI-WELD® 350.

MATERIALS NEEDED

- 3/8" Wrench or socket wrench
- Slot head screw driver
- 7/16" Wrench
- Resistor (25 – 1000 ohms, 25 watts minimum)
- Wiring Diagram

This procedure should take approximately 30 minutes to perform.

MULTI-WELD® 350



POWER CAPACITOR REMOVAL AND REPLACEMENT (*CONTINUED*)

FIGURE F.13 – POWER CAPACITOR MOUNTING DETAILS

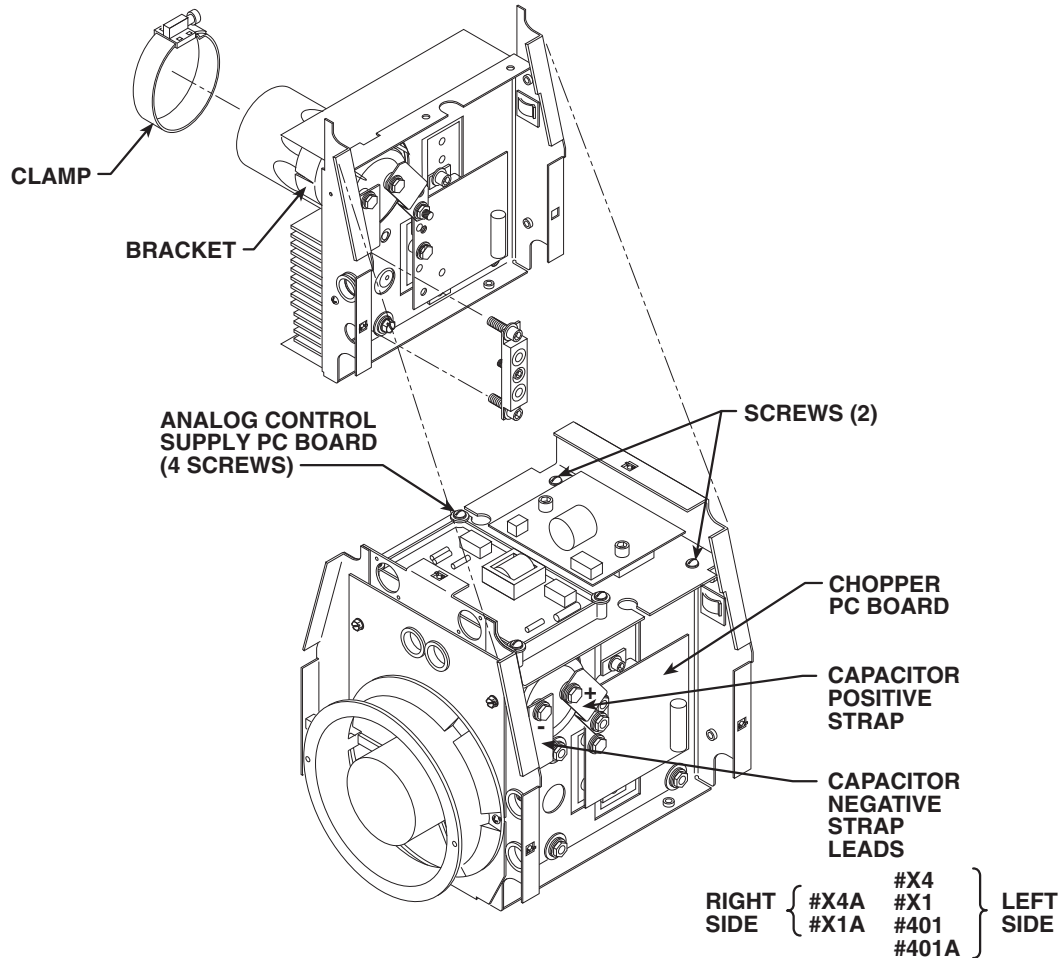
**PROCEDURE**

Refer to Figure F.13.

1. Set the CC/CV power switch to OFF.
2. Remove input power to the machine.

**WARNING**

ELECTRIC SHOCK can kill.

Disconnect input power before removing the case cover and performing tests or making repairs to the machine.

3. Perform the *Case Cover Assembly Removal Procedure*.
4. Perform the *Power Module Capacitor Discharge Procedure*.
5. Disconnect the two plug harness connections at the top of the tunnel assembly.
6. Disconnect the plug harness connection above each Chopper PC board.

POWER CAPACITOR REMOVAL AND REPLACEMENT (CONTINUED)

7. Using the slot head screw driver, remove the two screws and lock washers from the tunnel assembly top cover. Then remove the four screws, lock washers, and flat washers that mount the Analog Control Power Supply PC Board. This will allow you to access the clamps that hold the capacitors to their brackets in the heat sinks.
8. Lift off the top cover of the tunnel assembly. Peel away the adhesive-backed rubber stripping (if present) as necessary. Use care – the stripping may tear.
9. Using the slot head screw driver, loosen the clamp from around the bracket of the capacitor you want to remove.
10. Using the 7/16" wrench, remove heavy leads #X1, #X4 and small leads #401 and 401A (left side) or #X1A and #X4A (right side) of the capacitor terminals. Note the fasteners for reassembly: bolt, lock washer, and flat washer. See the Wiring Diagram.
11. Using the 7/16" wrench, remove the two bolts holding the negative strap to the diode module. Note the fasteners for reassembly: bolt, lock washer, two flat washers.
12. Using the 7/16" wrench, remove the two nuts holding the positive strap to the Chopper PC board. Hold the bolt head behind the board to remove each nut. Note the fasteners for reassembly: flat washer, lock washer, nut. Note the placement of the reverse diode lead on the bottom bolt.
13. Push the capacitor from the inside, out of the heat sink. Note that the bracket stays in the heat sink.

REASSEMBLY

1. Slide the capacitor into the heat sink. **Position the positive (+) terminal next to the Chopper PC board.**
2. Tighten the bracket clamp.
3. Replace the leads and straps as labeled (**Figure F.13**) and tighten the fasteners. Use the 7/16" socket and torque wrench to tighten the capacitor terminal bolt to 50-60 in-lbs. Tighten the nuts holding the positive strap to the Chopper PC board to 50-60 in-lbs.
4. Tighten the two 7/16" screws that hold the negative strap to the diode module to 30-40 in-lbs.
5. Replace any adhesive-backed rubber stripping, if present, that was damaged during disassembly.
6. Replace the Analog Control Power Supply PC Board.
7. Replace the tunnel assembly top cover.
8. Connect the wire harness plug assemblies above each Chopper PC Board and above the tunnel assembly (four plugs total).
9. Perform the **Case Cover Assembly Replacement Procedure**.

CHOPPER PC BOARD AND DIODE MODULE REMOVAL AND REPLACEMENT



WARNING

Service and repair should be performed by only Lincoln Electric factory trained personnel. Unauthorized repairs performed on this equipment may result in danger to the technician or machine operator and will invalidate your factory warranty. For your safety and to avoid electrical shock, please observe all safety notes and precautions detailed throughout this manual.

If for any reason you do not understand the test procedures or are unable to perform the test/repairs safely, contact the Lincoln Electric Service Department for electrical troubleshooting assistance before you proceed. Call 1-888-935-3877.

DESCRIPTION

This procedure will aid the technician in the removal and replacement of the Chopper PC Board and the Diode Module Assembly.

MATERIALS NEEDED

- 3/8" Wrench or socket wrench
- 7/16" Wrench or socket wrench
- 1/2" Wrench
- 3/16" Allen head wrench
- 9/64" Allen head wrench
- Torque wrench with 7/16" hex and 1/4" and 9/64" allen head sockets
- Phillips head screw driver
- Diagonal cutters
- Electrical thermal joint compound – Penetrox A-13
- Resistor (25 – 1000 ohms, 25 watts minimum)
- Small block of wood (approximately 1" x 3")

This procedure should take approximately 1 hour to perform.

CHOPPER PC BOARD REMOVAL AND REPLACEMENT (CONTINUED)

FIGURE F. 14 – CHOPPER PC BOARD AND DIODE MODULE CONNECTIONS

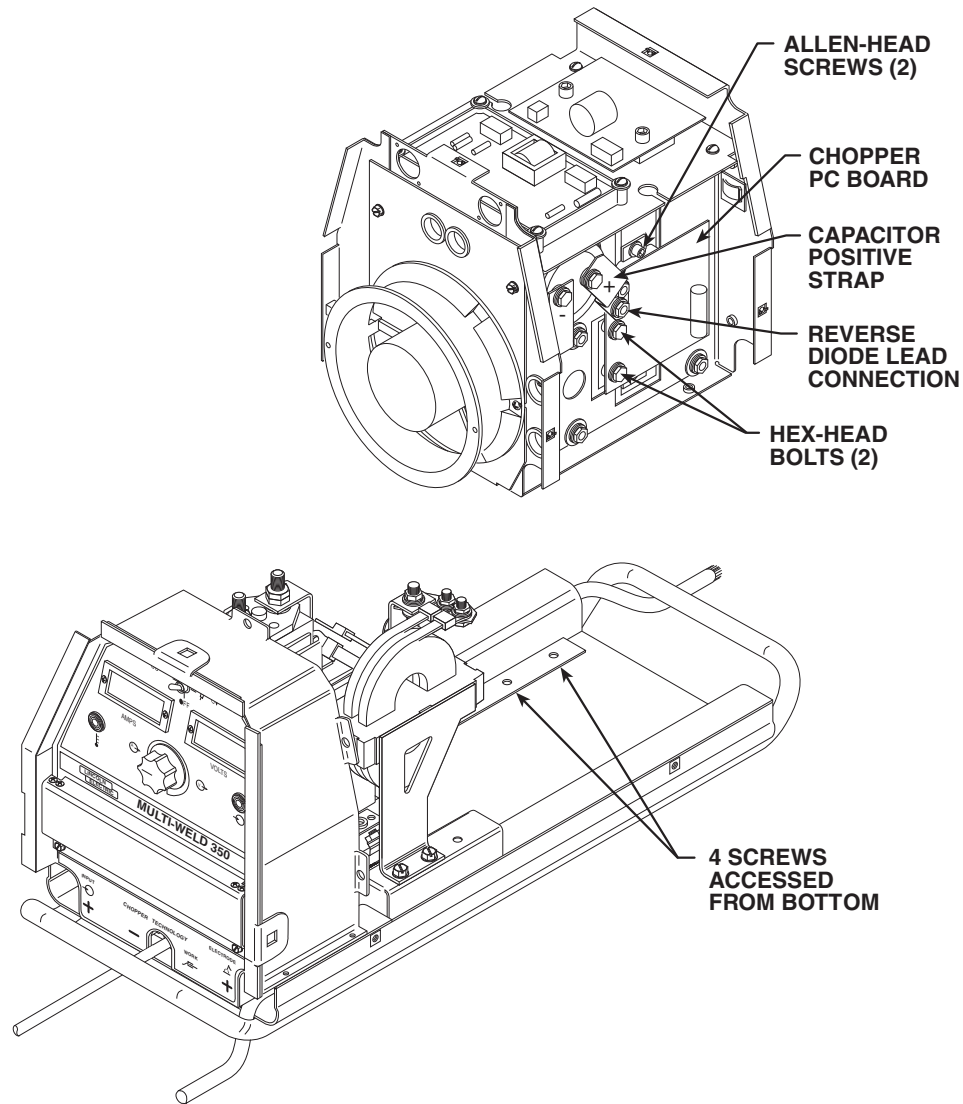

REMOVAL

Refer to Figure F.14.

1. Set the CC/CV power switch to OFF.
2. Remove input power to the machine.



WARNING

ELECTRIC SHOCK can kill.

Disconnect input power before removing the case cover and performing tests or making repairs to the machine.

MULTI-WELD® 350

LINCOLN
ELECTRIC

CHOPPER PC BOARD REMOVAL AND REPLACEMENT (CONTINUED)

3. Perform the **Case Cover Removal Procedure**.
4. Perform the **Power Module Capacitor Discharge Procedure**.
5. Carefully turn the machine onto its side.
6. Using the 3/8" wrench, remove the four screws holding the tunnel assembly to the machine base. Support the tunnel assembly, then carefully turn the machine back upright.
7. With the slot head screw driver, carefully raise the tunnel assembly unit about one inch and block it with the piece of wood. This will allow access to the bottom allen head screws on the Chopper PC Board. Peel away the adhesive-backed rubber stripping if present. Use care – the stripping may tear.
8. Disconnect the plug harness connection above the Chopper PC Board. Slip the wires out of the cord clip.
9. Using the 7/16" wrench, loosen the bolt at the positive capacitor terminal. Then remove the two nuts, lock washers and flat washers holding the positive strap to the Chopper PC Board. Hold the screw heads behind the board with your finger to remove the nuts. Note the placement of the reverse diode lead on the bottom bolt. Note the fastener order for reassembly: flat washer, lock washer, nut.
10. With the 7/16" wrench, remove the two hex-head bolts, lock washers, and flat washers holding the Chopper PC Board to the heat sink. Catch the copper stand-offs behind the board.
11. Using the 3/16" allen head wrench, remove the two allen-head screws and lock washers holding the Chopper PC Board to the heat sink.
12. Swing the positive capacitor strap out of the way and remove the Chopper PC Board.

REPLACEMENT

Refer to **Figure F.14**.

1. Make sure the mating surfaces between the copper and the heat sink are clean, dry, and free of grease.
2. Apply a thin coating of electrical thermal joint compound (Penetrox A-13) to the mating surfaces between the copper and the aluminum heat sink.
3. Using the torque wrench and 3/16" allen head socket, install the two allen-head screws and lock washers that hold the Chopper PC Board to the heat sink. Tighten the screws finger tight, then to between 24 and 28 in-lbs., then again to between 40 and 48 in-lbs.
4. Using the 7/16" socket and torque wrench, install the two bolts, lock washers, and flat washers that hold the Chopper PC Board to the heat sink. Note the two spacers required. Tighten the bolts finger tight, then to between 50 and 60 in-lbs.
5. Put the positive strap (+) in position and the proper heavy lead. Using the 7/16" wrench, tighten the bolt at the positive capacitor terminal to between 50 and 60 in-lbs. Then put the flat washers, lock washers and nuts on the board side of the strap with the reverse diode lead on the bottom connection. Tighten to between 50 and 60 in-lbs.
6. Remove the wooden blocking and carefully lower the tunnel assembly onto the machine base. Support the tunnel assembly and turn the machine onto its side.
7. With the 3/8" wrench, install the four screws that hold the tunnel assembly to the machine base. Turn the machine back upright.
8. Connect the harness plug above the Chopper PC board. Slip the wires into the cord clip.

See the procedures following for removal and replacement of the diode module. When procedures are complete, perform the **Case Cover Assembly Replacement Procedure**.

DIODE MODULE REMOVAL AND REPLACEMENT

FIGURE F.15 – DIODE MODULE MOUNTING DETAILS

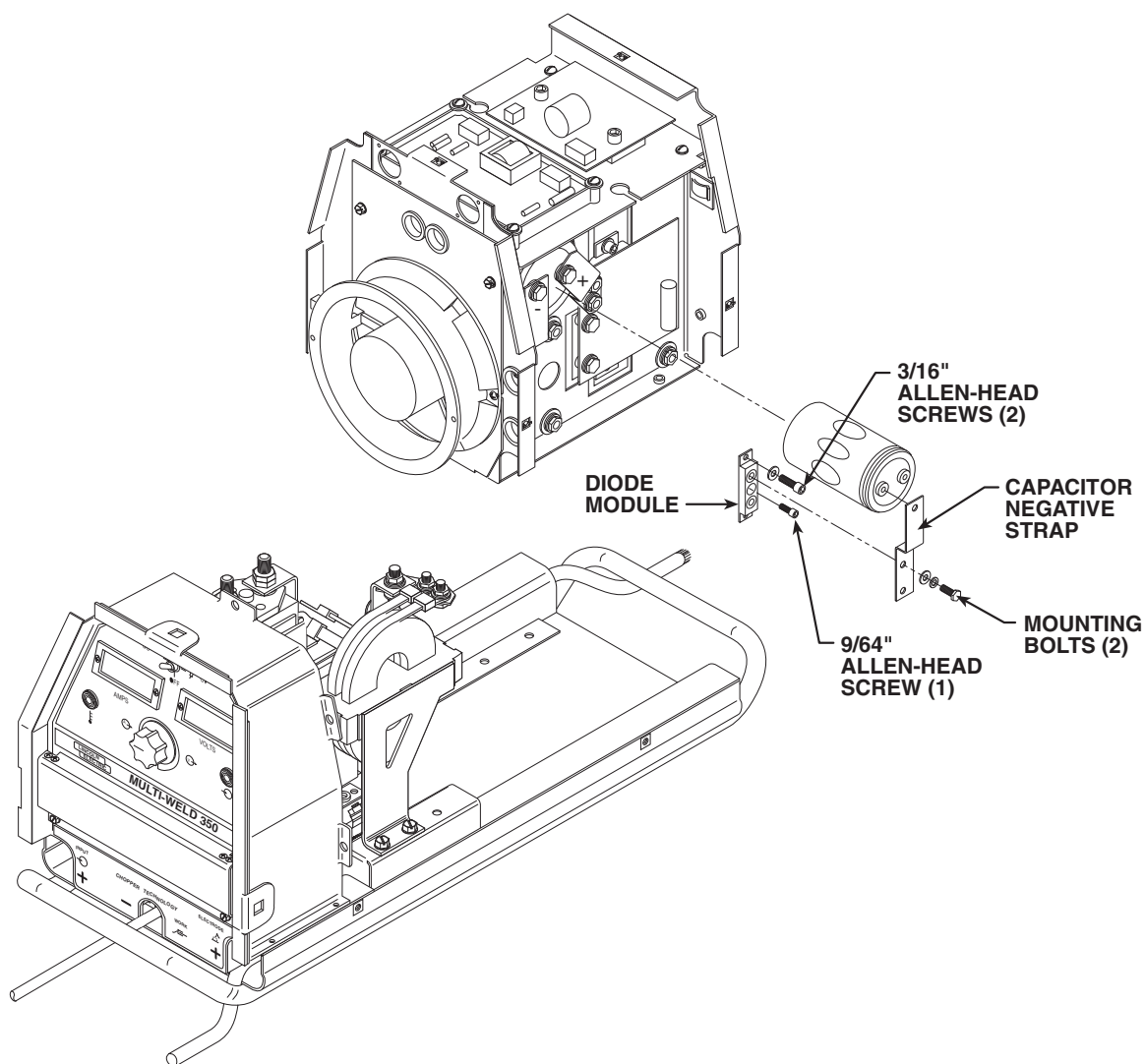
**REMOVAL**

Refer to Figure F.15.

1. Set the CC/CV power switch to OFF.
2. Remove input power to the machine.

**WARNING****ELECTRIC SHOCK can kill.**

Disconnect input power before removing the case cover and performing tests or making repairs to the machine.

MULTI-WELD® 350

LINCOLN
ELECTRIC

DIODE MODULE REMOVAL AND REPLACEMENT (CONTINUED)

3. Perform the **Case Cover Removal Procedure**.
4. Perform the **Power Capacitor Discharge Procedure**.
5. Carefully turn the machine onto its side.
6. Using the 3/8" wrench, remove the four screws holding the tunnel assembly to the machine base. Then carefully turn the machine back upright.
7. With the slot head screw driver, carefully raise the tunnel assembly unit about one inch and block it with the piece of wood. This will allow access to the bottom allen head screw on the diode module. Peel away the adhesive-backed rubber stripping as necessary. Use care – the stripping may tear.
8. Using the 7/16" wrench, remove the two outer screws, lock washers, and flat washers holding the negative capacitor strap to the diode module. Note fastener order for reassembly.
9. Using the 3/16" allen head wrench, remove the two screws, flat washers, and spring washers holding the diode module to the heat sink.
10. Using the 9/64" allen wrench, remove the set screw from the center of the diode module.
11. Remove the diode module from the heat sink.

REPLACEMENT

Refer to **Figure F.15**.



CAUTION

The proper tightening sequence is required to mount the diode module to the heat sink in order to avoid warping the base plate. Apply the proper torque to all fasteners.

1. Be sure the heat sink mounting surface is clean, dry, and free of grease.
2. Apply a thin, even coat (.1 to .25mm or .004 to .010 in) of Penetrox A13 thermal joint compound to the diode module base plate only, under the plastic body of the module. Do not apply compound to the area under the mounting holes.
3. Press the module firmly against the heat sink, aligning the mounting holes.

DIODE MODULE REMOVAL AND REPLACEMENT (CONTINUED)

FIGURE F.16 – DIODE MODULE TIGHTENING SEQUENCE

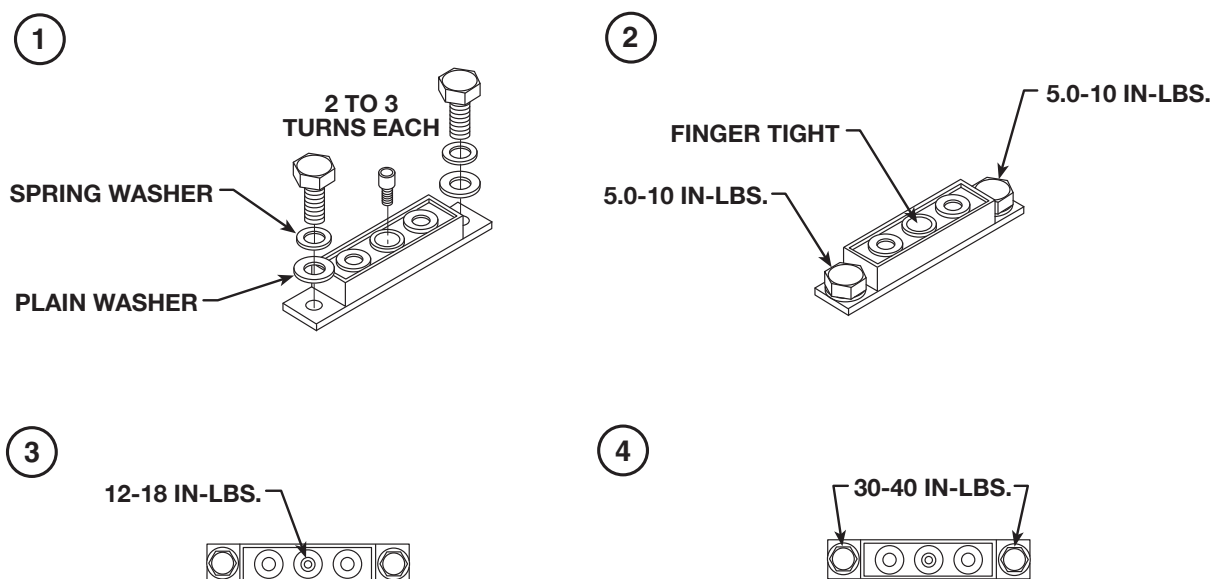

Refer to Figure F.16.

4. Place a spring washer then a flat washer over each outer mounting screw and insert them into the holes. Insert the allen head screw into the center hole. Tighten all three screws 2 – 3 turns each, finger-tight only. (1)
5. Using the torque wrench and 7/16" socket, tighten the outer screws to between 5.0 and 10 in-lbs. (2)
6. Using the torque wrench and 9/64" allen head socket, tighten the center screw between 12 and 18 in-lbs. (3)
7. Now tighten the two outer screws between 30 and 40 in-lbs. (4)
8. Place the negative capacitor strap over the diode module and align the mounting holes. Place a lock washer and two flat washers over each 7/16" screw and insert them into the holes. Using the torque wrench and 7/16" socket, tighten each screw between 30 and 40 in-lbs.
9. Install the 7/16" bolt, lock washer, flat washer, heavy lead and negative strap to the negative terminal on the capacitor. Tighten the bolt to 50-60 in-lbs.
10. Remove the wooden blocking and carefully lower the tunnel assembly onto the machine base. Support the tunnel assembly and turn the machine onto its side.
11. With the 3/8" wrench, install the four screws that hold the tunnel assembly to the machine base. Turn the machine back upright.
12. Perform the **Case Cover Assembly Replacement Procedure**.

MULTI-WELD® 350

LINCOLN
ELECTRIC

RETEST AFTER REPAIR

Retest a machine:

- If it is rejected under test for any reason that requires you to remove any mechanical part which could affect the machine's electrical characteristics. OR
- If you repair or replace any electrical components.

IDLE AMPS

Input Volts	Maximum Idle Amps
50 – 113 VDC	1 Amp

OPEN CIRCUIT VOLTAGES

Mode	Input Voltage	Open Circuit Voltage
CC Stick	72 – 113 VDC	74 – 78 VDC
CC Stick	60 – 72 VDC	Volts In + 4 VDC
CC Pipe (200 A preset)	72 – 113 VDC	73 – 78 VDC
CV Min. Preset	60 – 113 VDC	17 – 20 VDC
CV Max. Preset	60 – 113 VDC	50 – 54 VDC

LOAD TEST

Mode	Input Voltage	Output Amps and Volts
CC Stick/Gouge	60 – 113 VDC	100 Amps @ 24 VDC
CC Stick/Gouge	60 – 113 VDC	200 Amps @ 28 VDC
CC Stick/Gouge	60 – 113 VDC	350 Amps @ 34 VDC

FAN AS NEEDED (F.A.N.)

The fan should turn on when the machine is loaded and stay on for 50–70 seconds after the output load is removed.

TABLE OF CONTENTS -ELECTRICAL DIAGRAMS SECTION-

Electrical Diagrams	G-1
Wiring Diagram -Code 10645 (G3676)	G-2
Wiring Diagram -Code 10736 (G3676-1)	G-3
Wiring Diagram -Code 11148 (G4673)	G-4
Machine Schematic - Code 10736 (G3773)	G-5
Machine Schematic - Code 11148 (G3773-1)	G-6
Schematic – Control PC Board (G3661-2 Pg 1)	G-7
Schematic – Control PC Board (G3661-2 Pg 2)	G-8
Schematic – Control PC Board (G3661-2 Pg 3)	G-9
Schematic – Control PC Board (G3661-2 Pg 4)	G-10
Schematic – Control PC Board (G3661-2 Pg 5)	G-11
Schematic – Peripheral PC Board (G3663-1)	G-12
Schematic – Peripheral PC Board (G4661-2)	G-13
Schematic – DC Buss PC Board – All Codes (M19330-2)	G-14
PC Board Assembly – DC Buss PC Board - All Codes (L11078-2)	G-15
Schematic – Analog Power PC Board – All Codes (M19422-1)	G-16
Schematic – By-Pass PC Board – All Codes (S24726)	G-17
PC Board Assembly – By-Pass PC Board - All Codes (M19510-1)	G-18
Schematic – Chopper PC Board – All Codes (M19303)	G-19
PC Board Assembly – Chopper PC Board - All Codes (L11038-1)	G-20

*** NOTE:** Many PC Board Assemblies are now totally encapsulated, surface mounted and or multi-layered and are therefore considered to be unserviceable. Assembly drawings of these boards are no longer provided.

MULTI-WELD 350 WIRING DIAGRAM

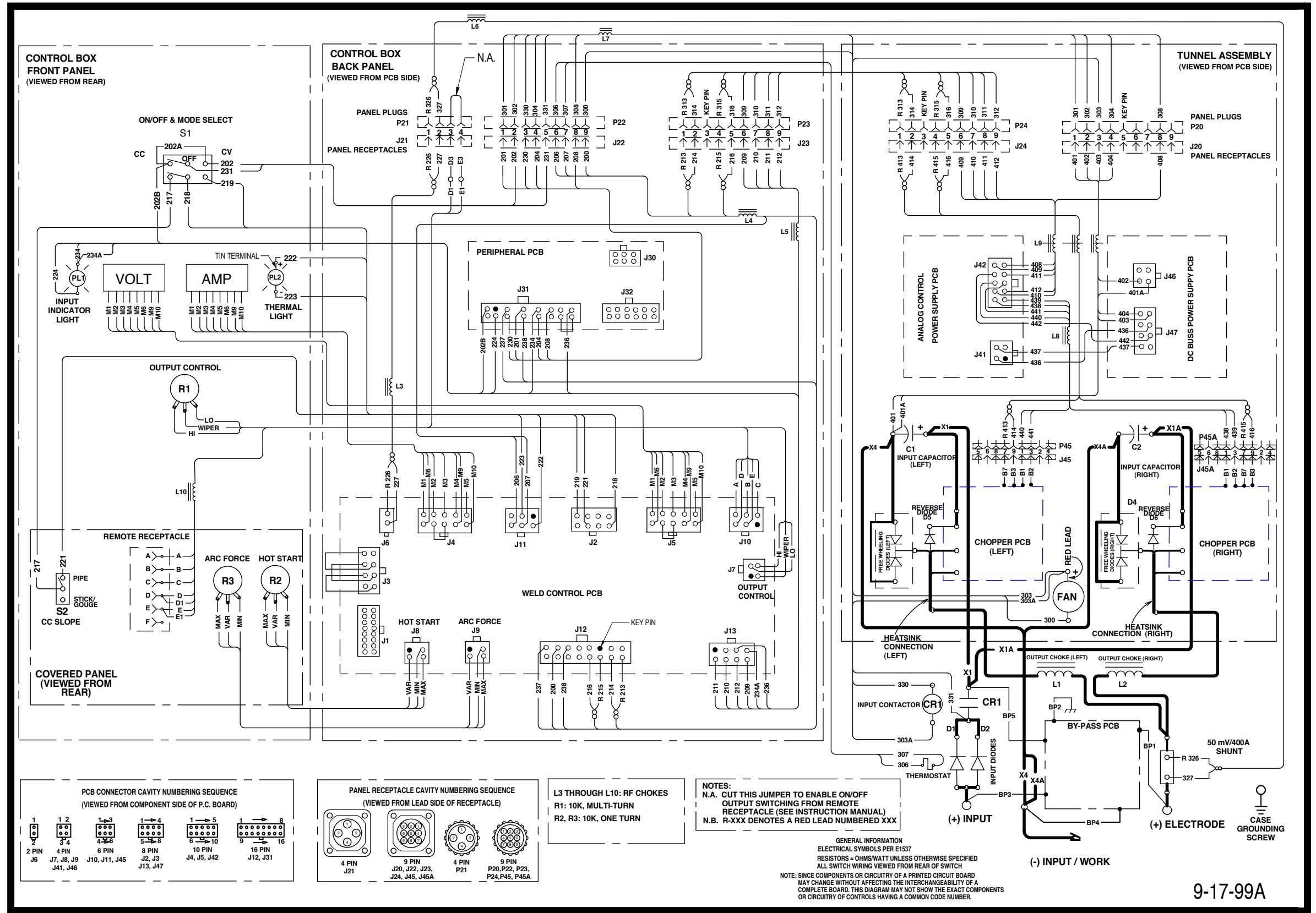

NOTE: This diagram is for reference only. It may not be accurate for all machines covered by this manual. The wiring diagram specific to your code is pasted inside one of the enclosure panels of your machine.

WIRING DIAGRAM - CODE 10736 (G3676-1)

MULTI-WELD 350 WIRING DIAGRAM

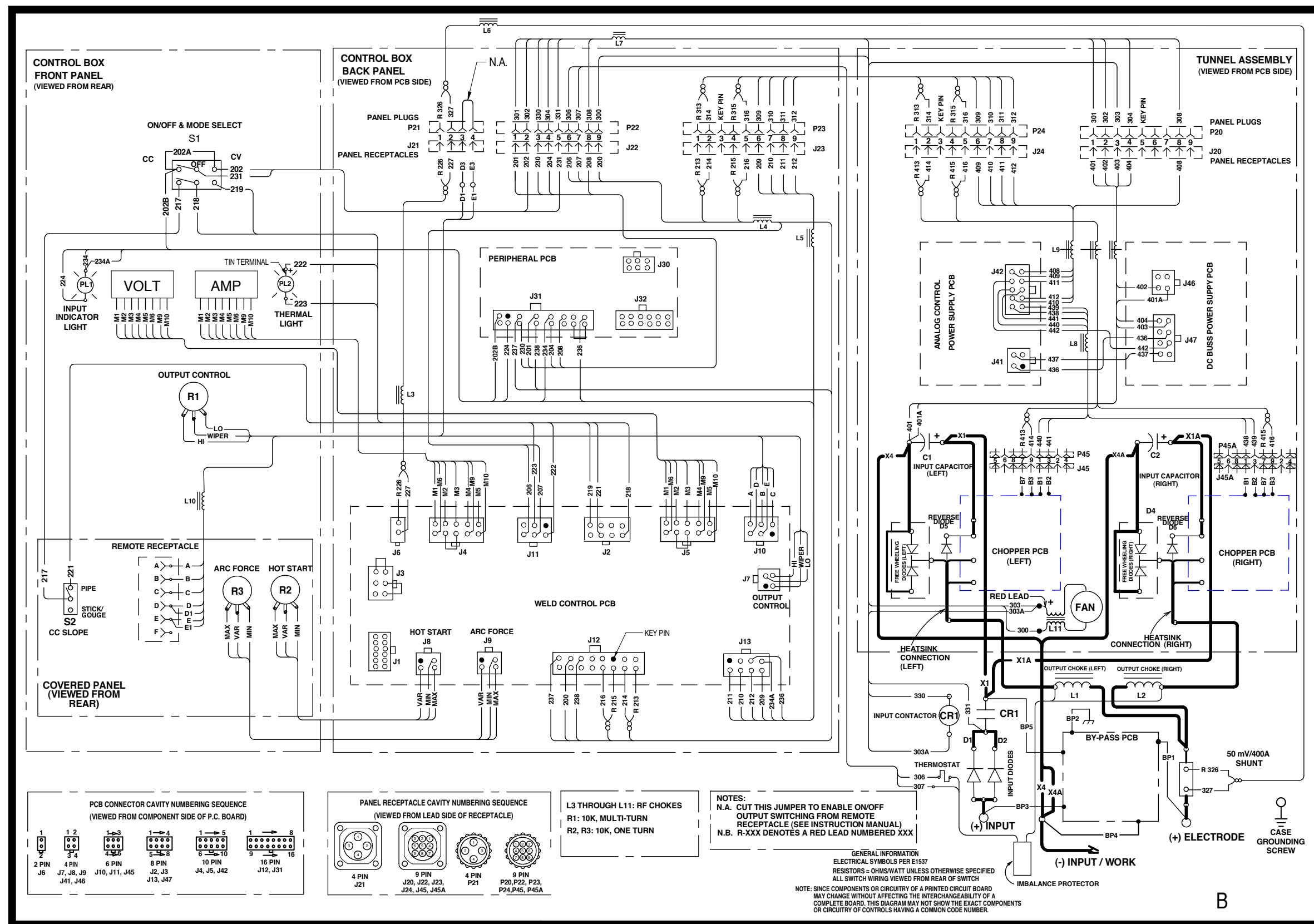

G3676-1

NOTE: This diagram is for reference only. It may not be accurate for all machines covered by this manual. The wiring diagram specific to your code is pasted inside one of the enclosure panels of your machine.



MULTI-WELD 350 WIRING DIAGRAM

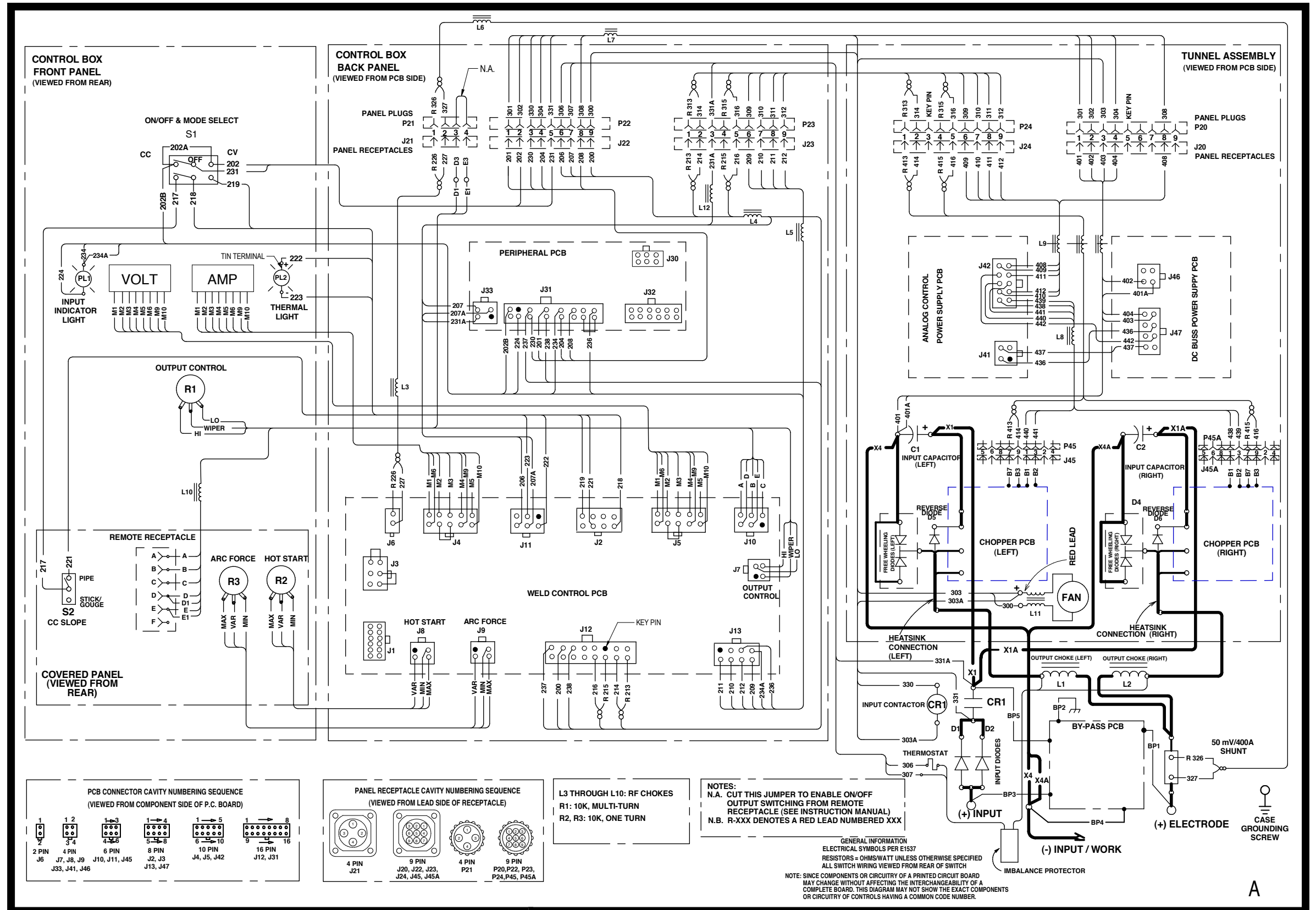

G4673

NOTE: This diagram is for reference only. It may not be accurate for all machines covered by this manual. The wiring diagram specific to your code is pasted inside one of the enclosure panels of your machine.



MULTI-WELD® 350

MACHINE SCHEMATIC - CODE 10736 (G3773)

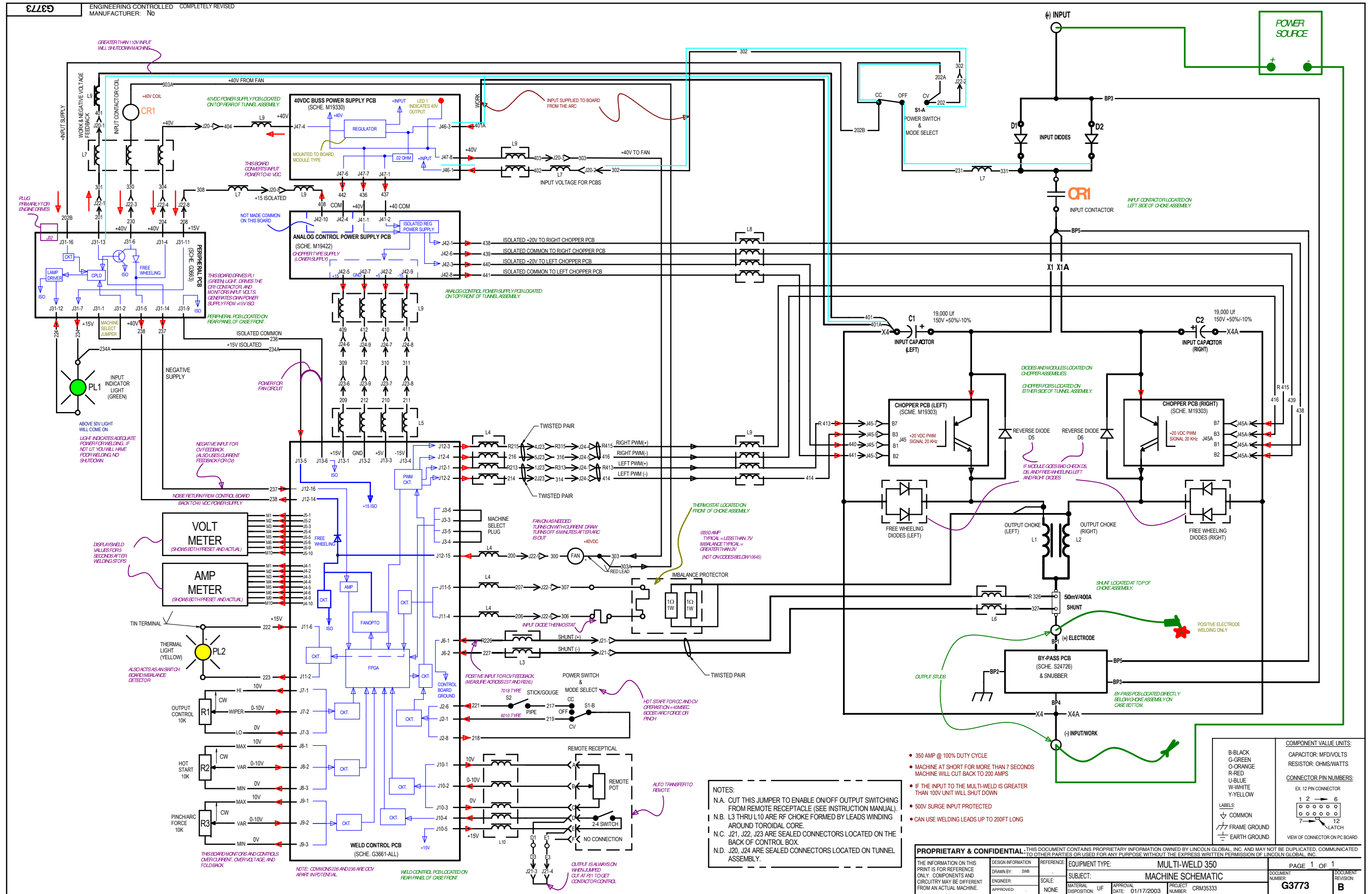

NOTE: This diagram is for reference only. It may not be accurate for all machines covered by this manual.

Return to Section TOC
Return to Master TOC

Return to Section TOC
Return to Master TOC

Return to Section TOC
Return to Master TOC

Return to Section TOC
Return to Master TOC

MACHINE SCHEMATIC - CODE 11148 (G3773-1)

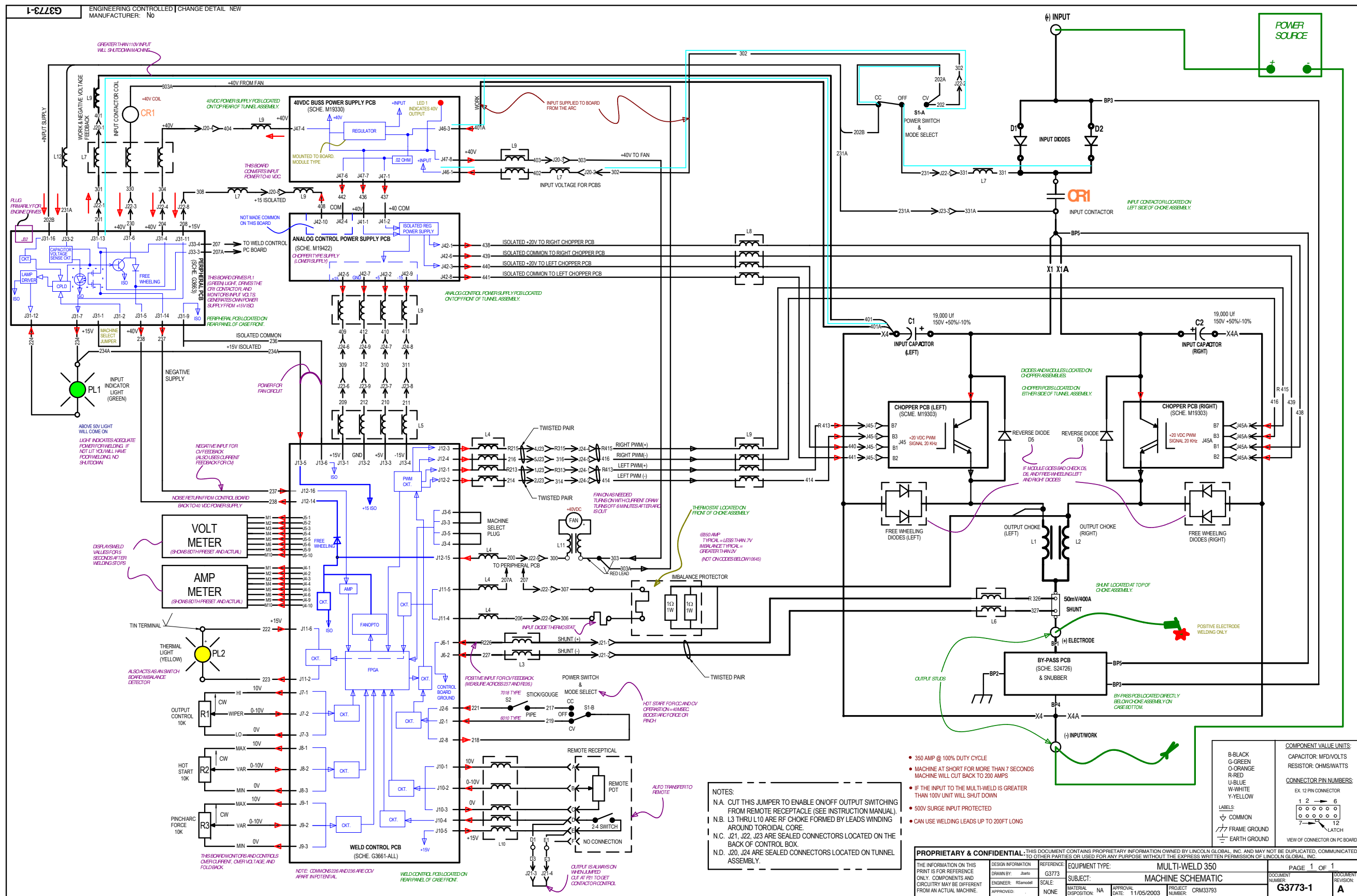

NOTE: This diagram is for reference only. It may not be accurate for all machines covered by this manual.

Return to Section TOC | Return to Master TOC

SCHEMATIC - CONTROL PC BOARD (G3661-2) PG 1

Return to Section TOC

Return to Section TOC

Return to Section TOC

Return to Section TOC

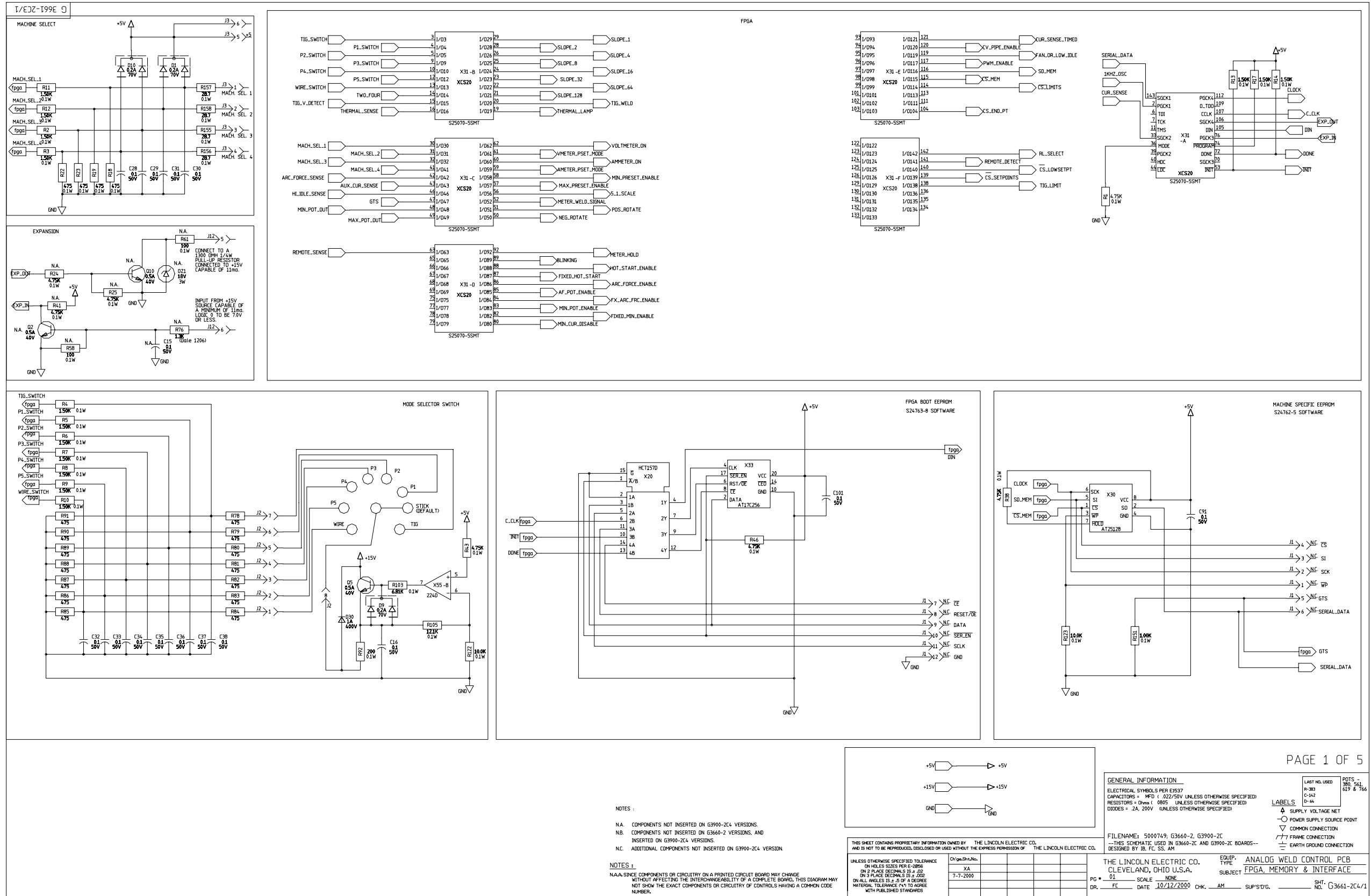

NOTE: This diagram is for reference only. It may not be accurate for all machines covered by this manual.



SCHEMATIC - CONTROL PC BOARD (G3661-2) PG 2

Return to Section TOC

Return to Section TOC

Return to Section TOC

Return to Section TOC

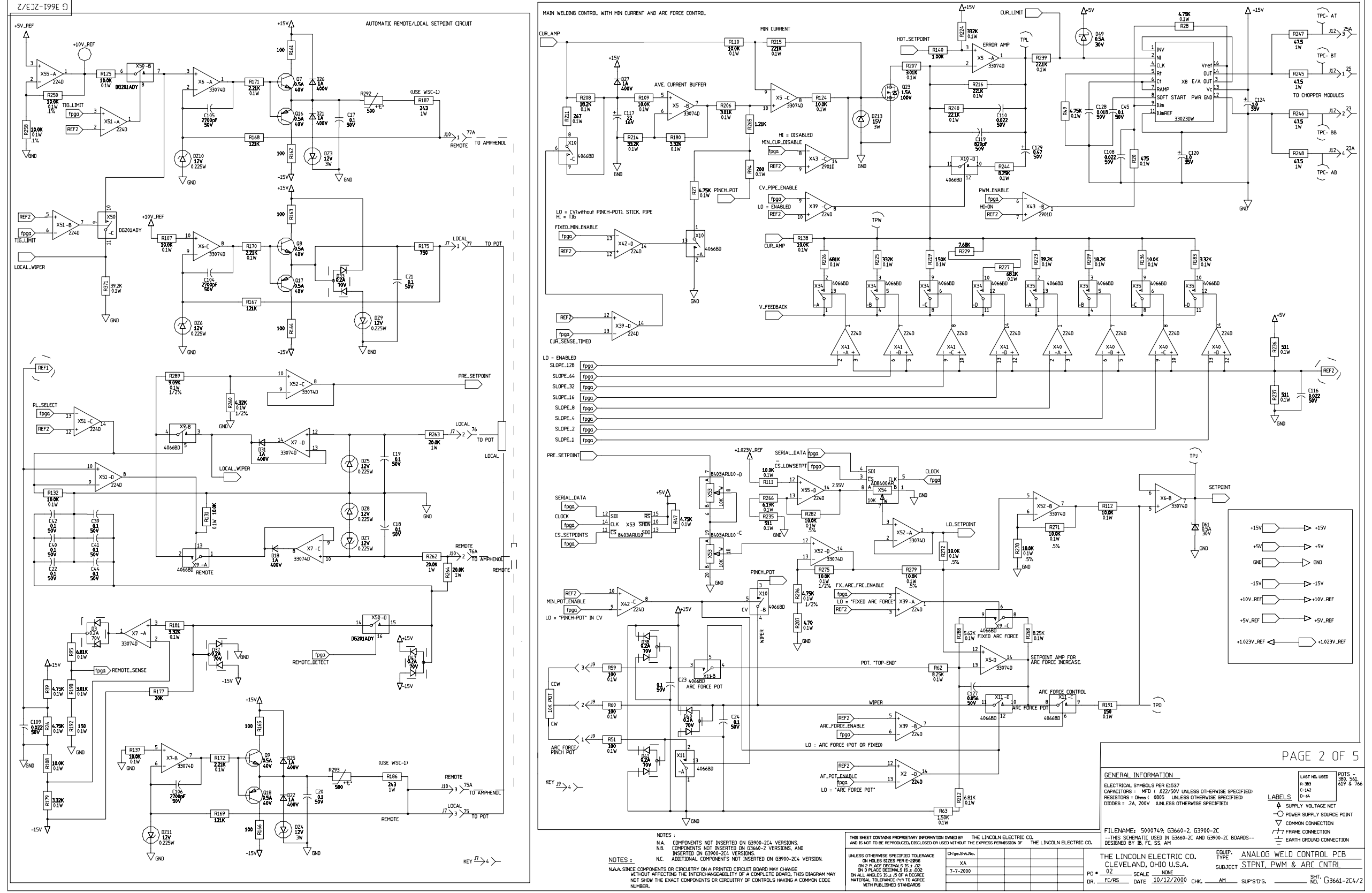

NOTE: This diagram is for reference only. It may not be accurate for all machines covered by this manual.



SCHEMATIC - CONTROL PC BOARD (G3661-2) PG 3

Return to Section TOC

Return to Section TOC

Return to Section TOC

Return to Section TOC

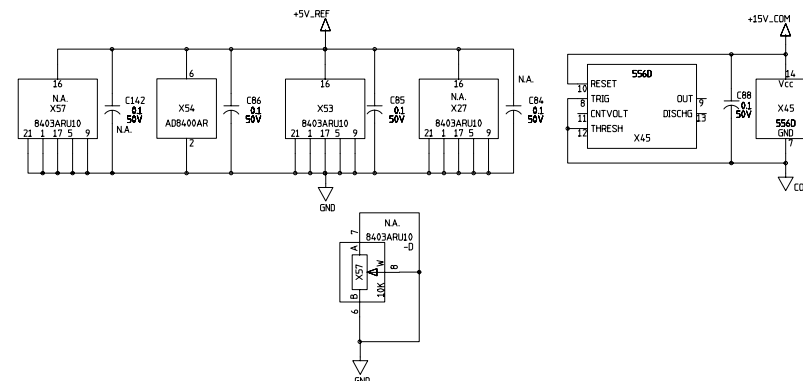
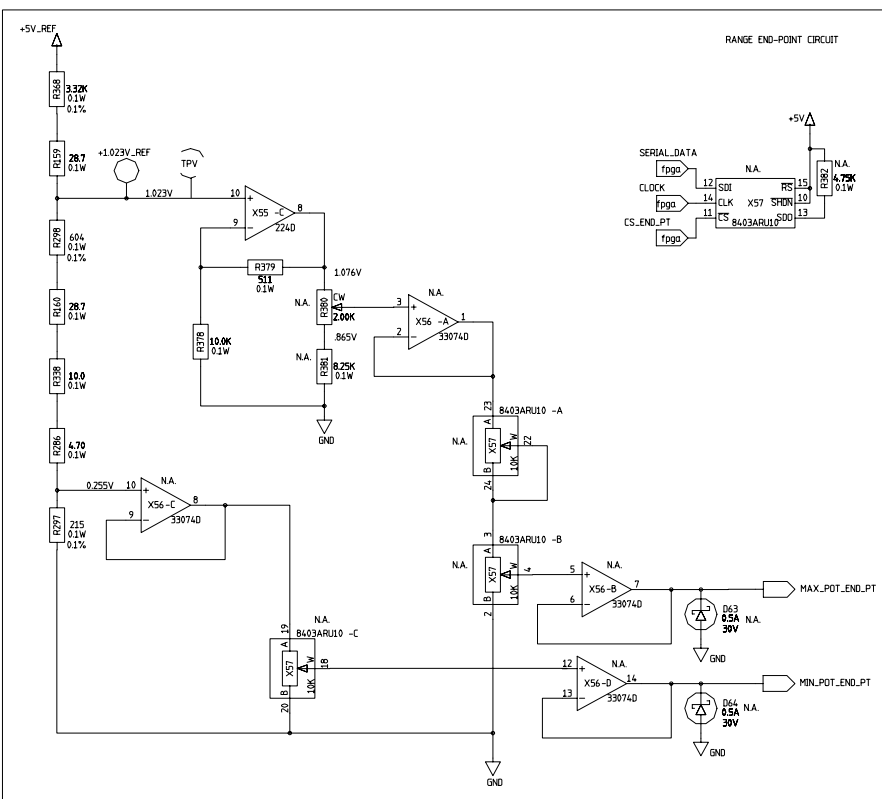
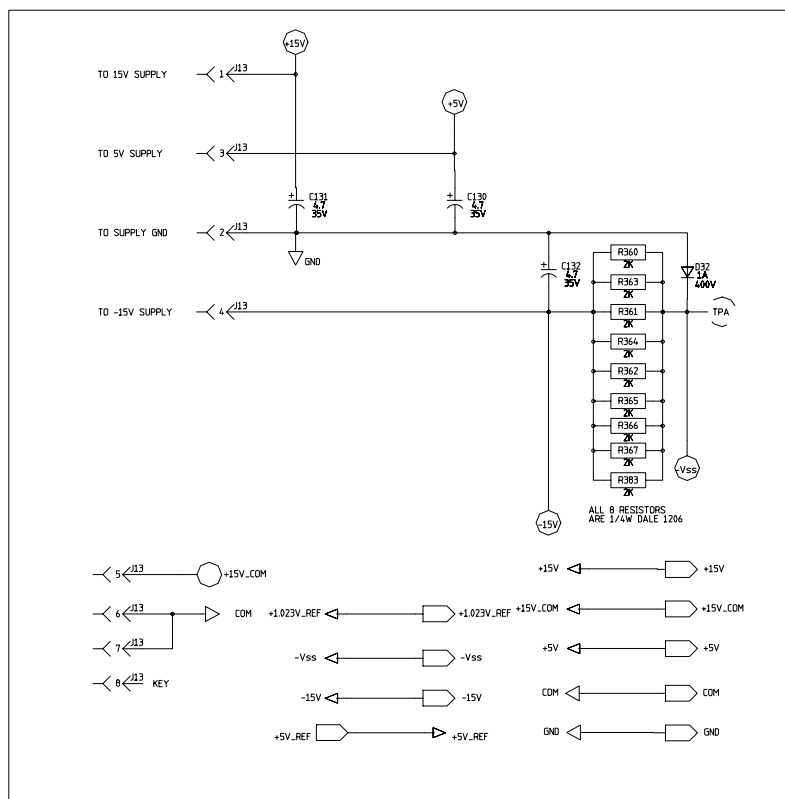
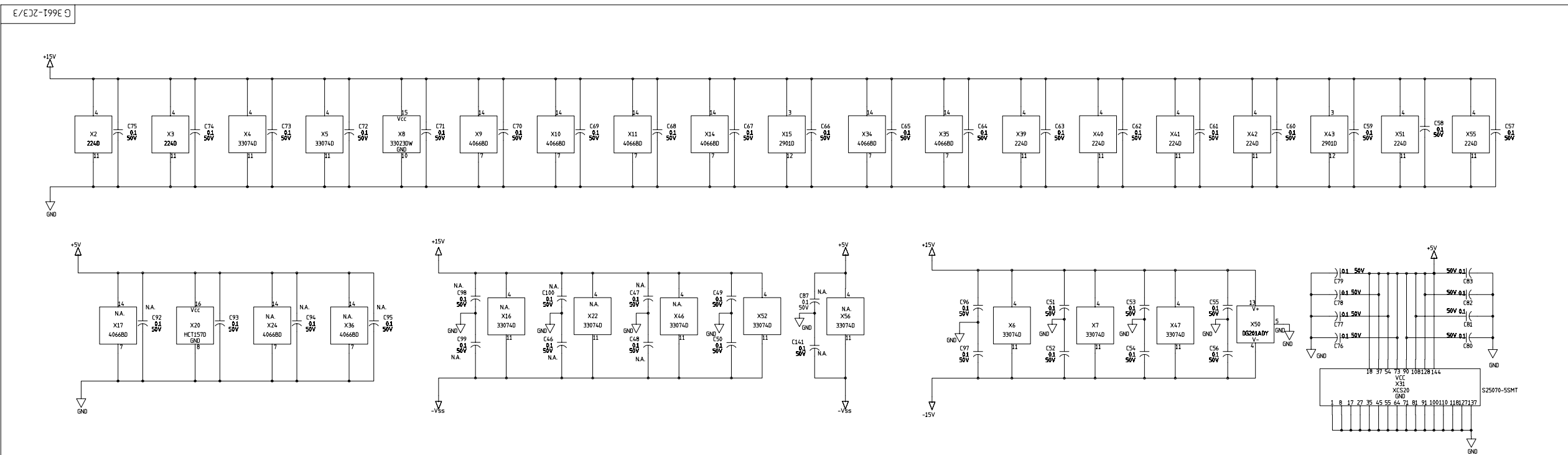

NOTES:
 N.A. COMPONENTS NOT INSERTED ON G3900-2C4 VERSIONS.
 NB COMPONENTS NOT INSERTED ON G3660-2 VERSIONS, AND INSERTED ON G3660-2C4 VERSIONS.
 NC ADDITIONAL COMPONENTS NOT INSERTED ON G3660-2C4 VERSION.
 N.A.A. SINCE COMPONENTS OR CIRCUITRY ON A PRINTED CIRCUIT BOARD MAY CHANGE WITHOUT AFFECTING THE INTERCHANGEABILITY OF A COMPLETE BOARD, THIS DIAGRAM MAY NOT SHOW THE EXACT COMPONENTS OR CIRCUITRY OF CONTROLS HAVING A COMMON CODE NUMBER.

THIS SHEET CONTAINS PROPRIETARY INFORMATION OWNED BY THE LINCOLN ELECTRIC CO. AND IS NOT TO BE REPRODUCED, DISCLOSED OR USED WITHOUT THE EXPRESS PERMISSION OF THE LINCOLN ELECTRIC CO.

UNLESS OTHERWISE SPECIFIED TOLERANCE ON HOLES SIZES PER E-2898 ON 3 PLACE DECIMALS IS ±.002 ON 4 PLACE DECIMALS IS ±.0005 MATERIAL TOLERANCE: ±.1 TO AGREE WITH PUBLISHED STANDARDS

Chg. No. | Date | Description | Rev. |
 7-7-2000 | | | |

THE LINCOLN ELECTRIC CO. CLEVELAND, OHIO U.S.A. EQUIP. TYPE ANALOG WELD CONTROL PCB
 PG. 03 SCALE NONE SUBJECT POWER CONNECTIONS, ECT.
 DR. FC DATE 10/12/2000 CHK. AM SUP'D/G. SHT. NO. G3661-2C4/3

GENERAL INFORMATION
 ELECTRICAL SYMBOLS PER E1537
 CAPACITORS = MFD (.022/50V UNLESS OTHERWISE SPECIFIED)
 RESISTORS = Ohms (9805 UNLESS OTHERWISE SPECIFIED)
 DIODES = .2A, 200V UNLESS OTHERWISE SPECIFIED

PAGE 3 OF 5
 LAST NO. USED 395, 541, 619 & 766
 LABELS R-383, C-142, D-44
 SUPPLY VOLTAGE NET
 POWER SUPPLY SOURCE POINT
 COMMON CONNECTION
 FRAME CONNECTION
 EARTH GROUND CONNECTION

NOTE: This diagram is for reference only. It may not be accurate for all machines covered by this manual.



SCHEMATIC - CONTROL PC BOARD (G3661-2) PG 4

Return to Section TOC

Return to Section TOC

Return to Section TOC

Return to Section TOC

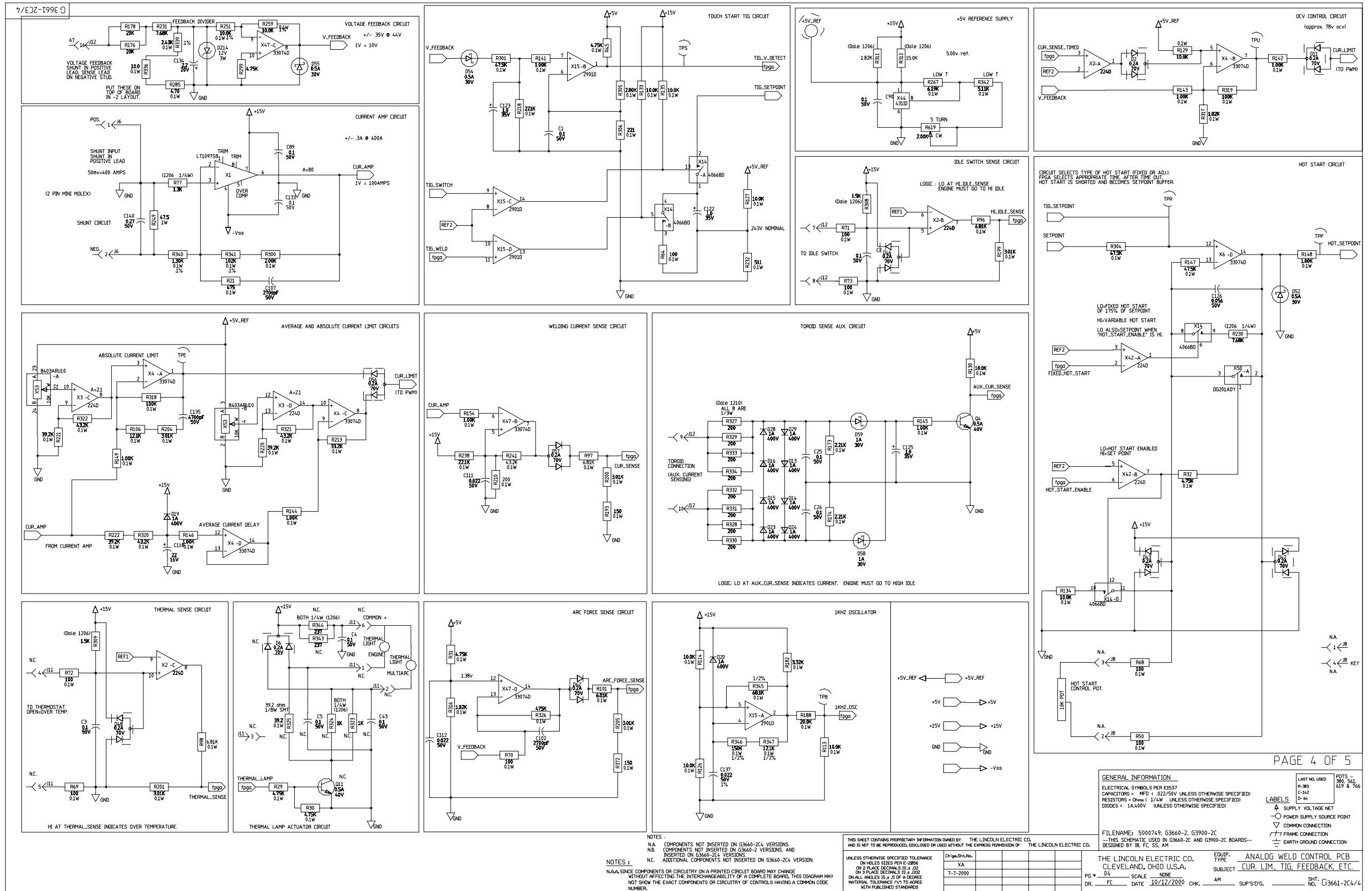

NOTE: This diagram is for reference only. It may not be accurate for all machines covered by this manual.



SCHEMATIC - CONTROL PC BOARD (G3661-2) PG 5

Return to Section TOC

Return to Section TOC

Return to Section TOC

Return to Section TOC

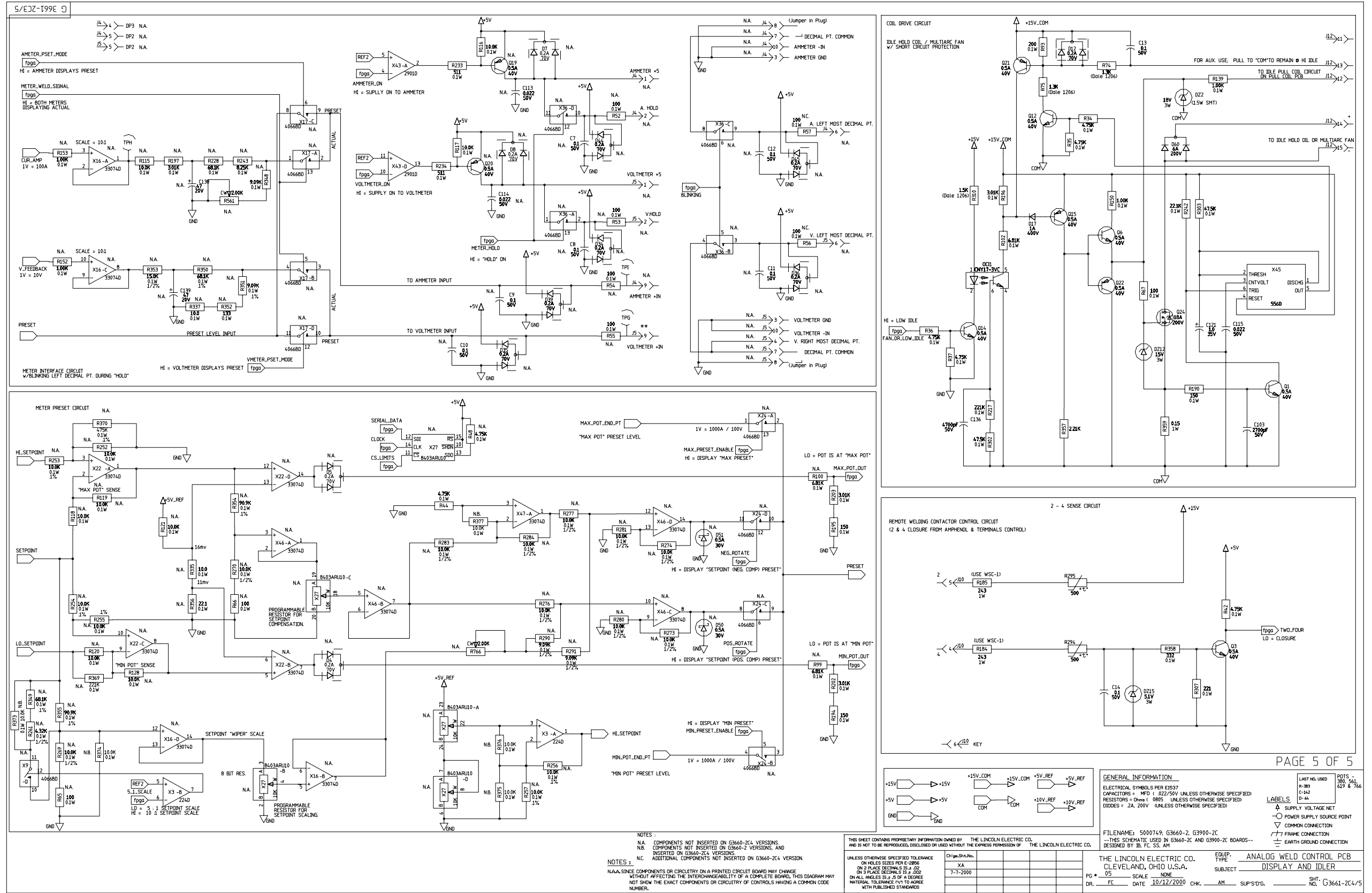

NOTE: This diagram is for reference only. It may not be accurate for all machines covered by this manual.

SCHEMATIC - PERIPHERAL PRINTED CIRCUIT BOARD (G3663-1)

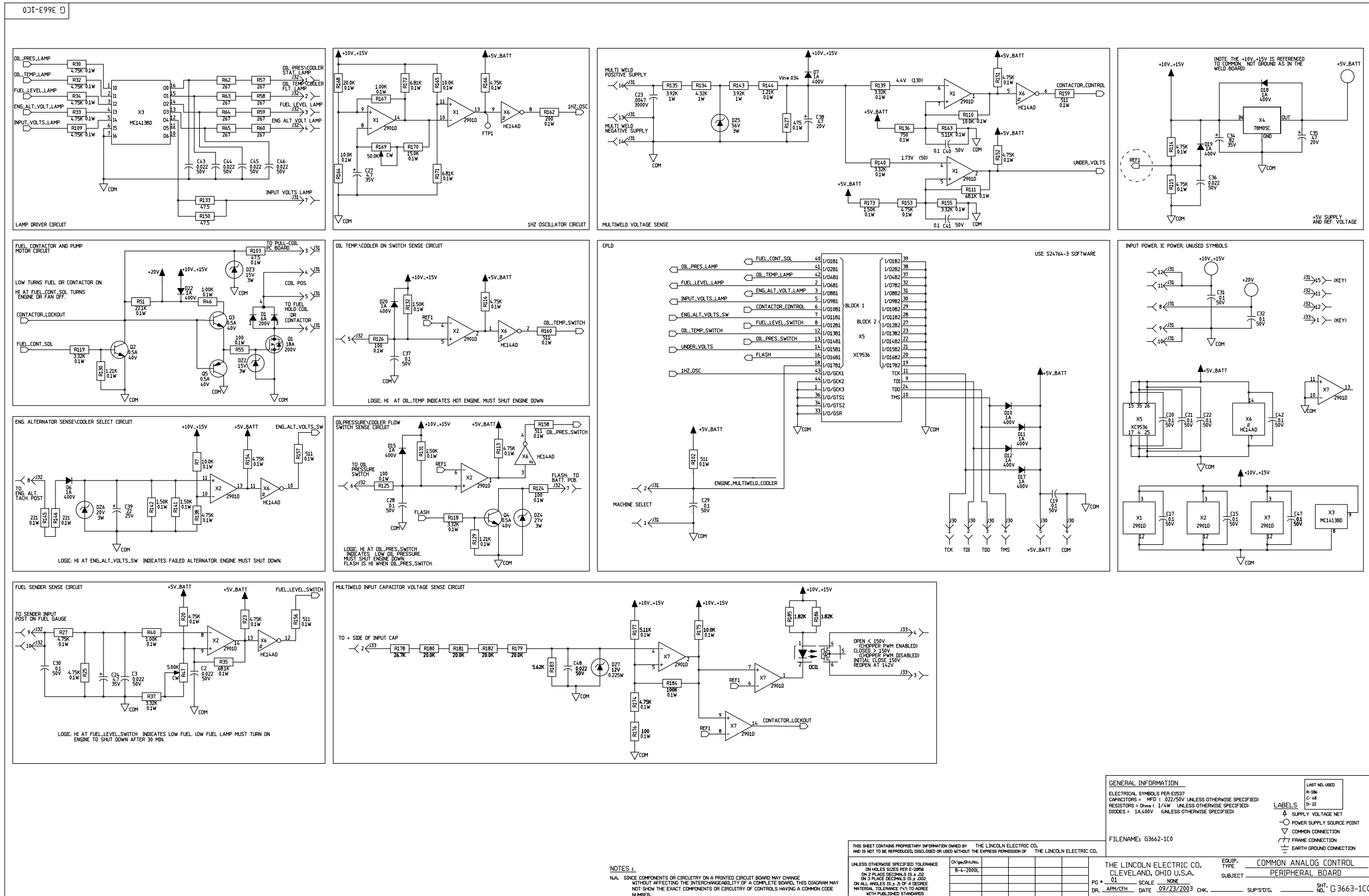

NOTE: This diagram is for reference only. It may not be accurate for all machines covered by this manual.

Return to Section TOC

Return to Section TOC

Return to Section TOC

Return to Section TOC

Return to Master TOC

Return to Master TOC

Return to Master TOC

Return to Master TOC

SCHEMATIC - PERIPHERAL PRINTED CIRCUIT BOARD (G4661-2)

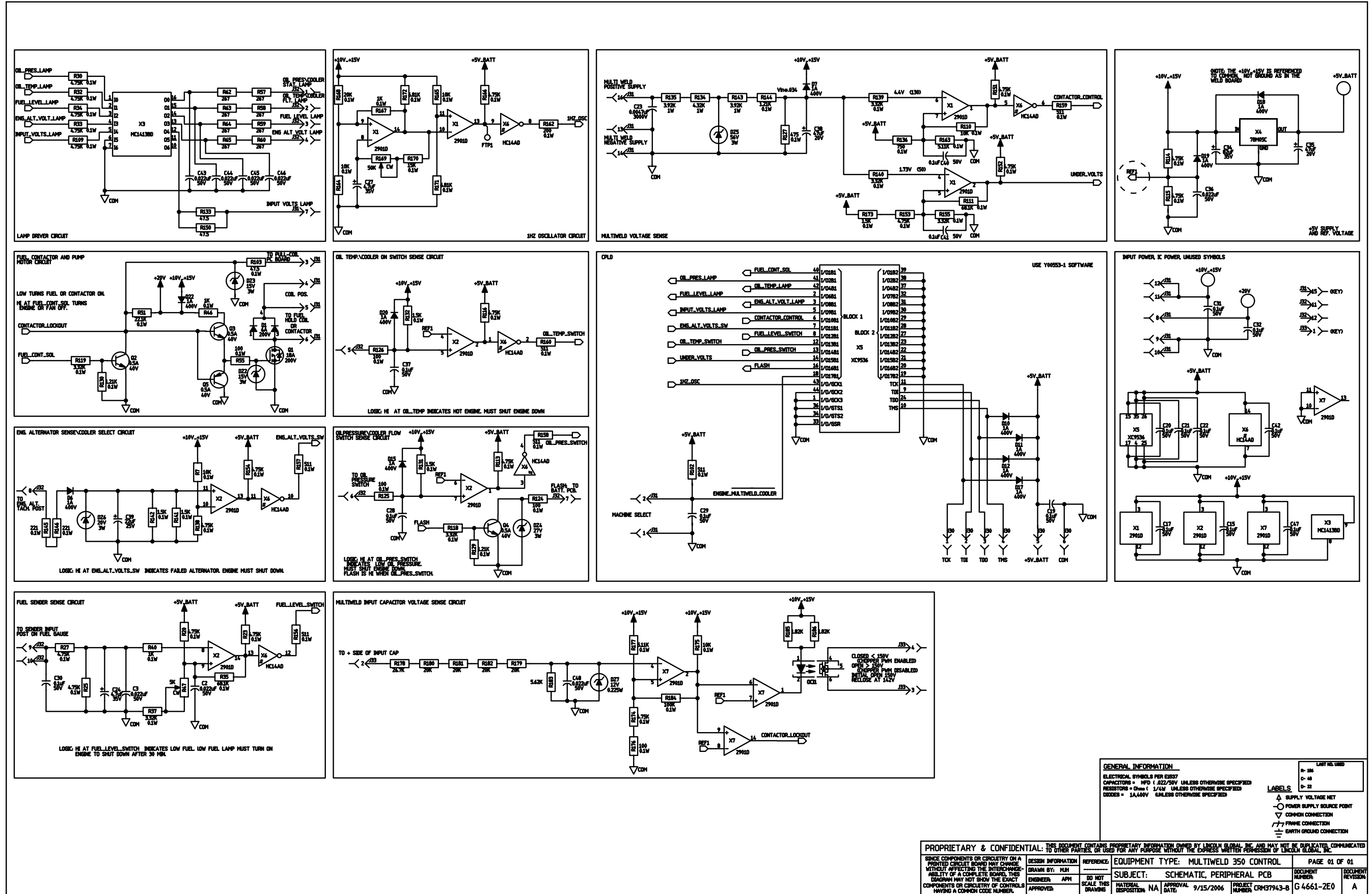

GENERAL INFORMATION

ELECTRICAL SYMBOLS PER ESD77
CAPACITORS = 10% 1/22/50V UNLESS OTHERWISE SPECIFIED
RESISTORS = 0.5% 1/4W UNLESS OTHERWISE SPECIFIED
DIMENSIONS = 1A/4MM UNLESS OTHERWISE SPECIFIED

LEGEND

○ SUPPLY VOLTAGE NET
○ POWER SUPPLY SOURCE POINT
▽ COMMON CONNECTION
// FRAME CONNECTION
≡ EARTH GROUND CONNECTION

PROPRIETARY & CONFIDENTIAL: THIS DOCUMENT CONTAINS PROPRIETARY INFORMATION OWNED BY LINCOLN GLOBAL, INC. AND MAY NOT BE REPLICATED, COMMUNICATED OR USED FOR ANY PURPOSE WITHOUT THE EXPRESS WRITTEN PERMISSION OF LINCOLN GLOBAL, INC.

DESIGN INFORMATION	REVISION	EQUIPMENT TYPE: MULTIWELD 350 CONTROL	PAGE 01 OF 01
DRAWN BY: MJM	NO. 01	SUBJECT: SCHEMATIC, PERIPHERAL PCB	DOCUMENT NUMBER: G4661-2E0
ENGINEER: APH	SCALE: THIS DRAWING	MATERIAL DISPOSITION: NA	APPROVAL DATE: 9/15/2006
APPROVED:		PROJECT NUMBER: CRM37943-8	REVISION: A

NOTE: This diagram is for reference only. It may not be accurate for all machines covered by this manual.



SCHEMATIC - DC BUSS BOARD - ALL CODES (M19330-2)

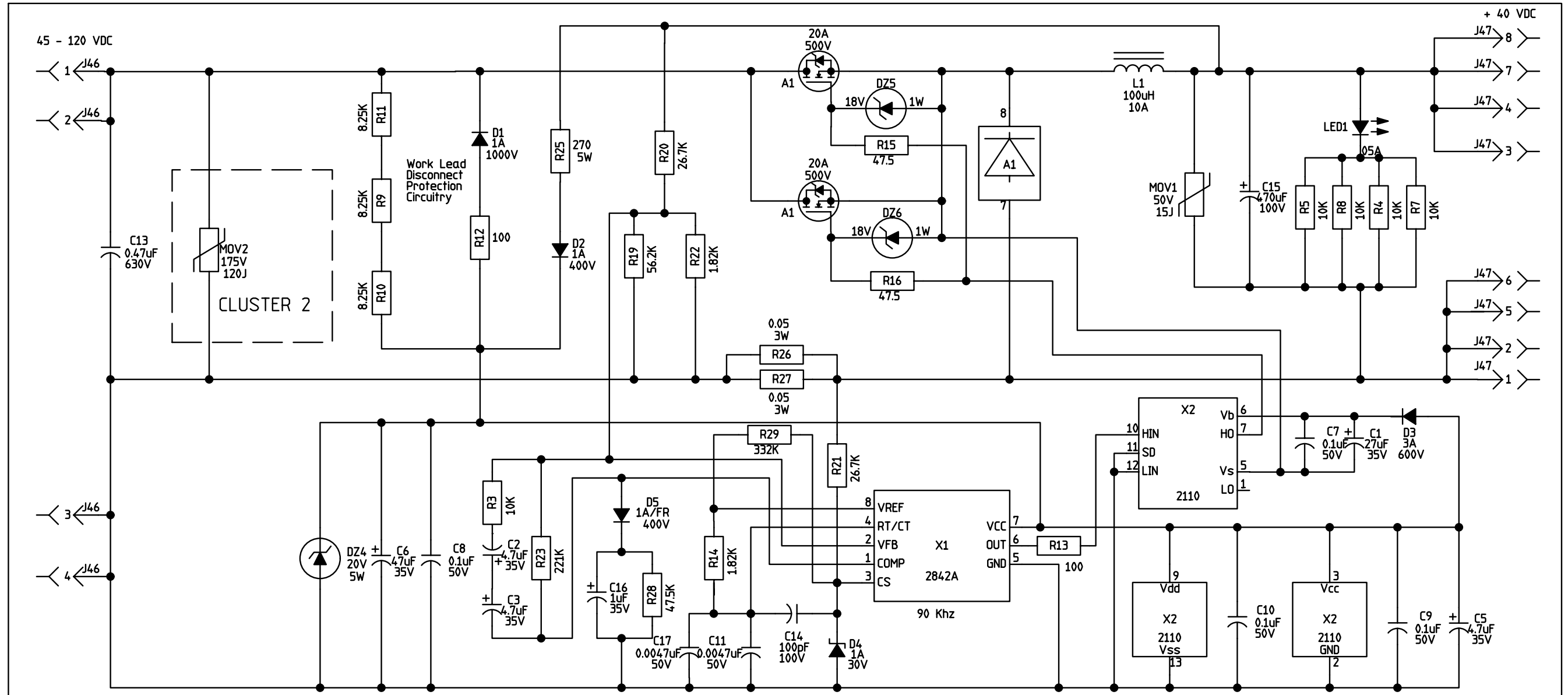

CLUSTER 1

GENERAL INFORMATION

ELECTRICAL SYMBOLS PER E1537
 CAPACITORS = MFD (.022/50V UNLESS OTHERWISE SPECIFIED)
 RESISTORS = Ohms (1/4W UNLESS OTHERWISE SPECIFIED)
 DIODES = 1A,400V (UNLESS OTHERWISE SPECIFIED)

LABELS

- ▲ SUPPLY VOLTAGE NET
- POWER SUPPLY SOURCE POINT
- ▽ COMMON CONNECTION
- ⎓ FRAME CONNECTION
- ⊥ EARTH GROUND CONNECTION

LAST NO. USED		
R- 29	MOV- 2	X- 2
C- 17	LED- 1	L- 1
D- 5	DZ- 6	A- 1

L11078-2	1
L11832-2	1 & 2
ASSEMBLY NO.	CLUSTER NO.

PROPRIETARY & CONFIDENTIAL: THIS DOCUMENT CONTAINS PROPRIETARY INFORMATION OWNED BY LINCOLN GLOBAL, INC. AND MAY NOT BE DUPLICATED, COMMUNICATED TO OTHER PARTIES, OR USED FOR ANY PURPOSE WITHOUT THE EXPRESS WRITTEN PERMISSION OF LINCOLN GLOBAL, INC.

SINCE COMPONENTS OR CIRCUITRY ON A PRINTED CIRCUIT BOARD MAY CHANGE WITHOUT AFFECTING THE INTERCHANGEABILITY OF A COMPLETE BOARD, THIS DIAGRAM MAY NOT SHOW THE EXACT COMPONENTS OR CIRCUITRY OF CONTROLS HAVING A COMMON CODE NUMBER.	DESIGN INFORMATION	REFERENCE:	EQUIPMENT TYPE: MULTI-SYSTEMS 40 VDC BUSS	PAGE 01 OF 01	
	DRAWN BY: TEK	-----	SUBJECT: SCHEMATIC, POWER SUPPLY PCB	DOCUMENT NUMBER:	DOCUMENT REVISION:
ENGINEER: TN	DO NOT SCALE THIS DRAWING	MATERIAL DISPOSITION: NA	APPROVAL DATE: 9/8/2006	PROJECT NUMBER: CRM38151-A	M19330-2C0
APPROVED:					A

NOTE: This diagram is for reference only. It may not be accurate for all machines covered by this manual.

PC BOARD ASSEMBLY - DC BUSS BOARD - ALL CODES (L11078-2)

Return to Section TOC
Return to Master TOC

Return to Section TOC
Return to Master TOC

Return to Section TOC
Return to Master TOC

Return to Section TOC
Return to Master TOC

2-820117	ENGINEERING CONTROLLED MANUFACTURER: No	CHANGE DETAIL: UPDATED GRAPHICS	
-----------------	--	---------------------------------	--

P.C. BOARD BLANK INFORMATION

BUY COMPLETE AS L11078-C (4 LAYER BOARD PER E3281)
MAKES 12 BOARDS PER PANEL. PANEL SIZE PER E1911.
(SEE ELECTRONIC FILE FOR ADDITIONAL INFORMATION)

POTTING DIMENSIONS

MAKE PER E1911-ROHS
POT PER E1911-E-ROHS
TEST PER E3862
SCHEMATIC REFERENCE - M19330-2C0

MANUFACTURED AS:
L11078-2C0
IDENTIFICATION CODE

REFERENCE	QTY	PART NO.	DESCRIPTION
A1	1	M21214-6	ELECTRONIC MODULE, 2 MOSFETS(T12704-71)WITH 1DIO
C1	1	S13490-93	CAPACITOR, TAEI, 27, 35V, 10%
C2, C3, C5	3	S13490-25	CAPACITOR, TAEI, 4.7, 35V, 10%
C6	1	S13490-66	CAPACITOR, TAEI, 47, 35V, 10%
C7, C8, C9, C10	4	S16668-11	CAPACITOR, CEMO, 0.1, 50V, 10%
C11, C17	2	S16668-10	CAPACITOR, CEMO, 4700P, 50V, 2%
C13	1	S20500-2	CAPACITOR, PPMF, 0.47, 630V, 10%, BOX
C14	1	S16668-3	CAPACITOR, CEMO, 100P, 100V, 5%
C15	1	S13490-174	CAPACITOR, ALEI, 470, 100V, +50/-10%, LOW PROFILE
C16	1	S13490-42	CAPACITOR, TAEI, 1.0, 35V, 10%
D1	1	T12199-2	DIODE, AXLDS, 1A, 1000V
D2	1	T12199-1	DIODE, AXLDS, 1A, 400V
D3	1	T12705-59	DIODE, AXLDS, 3A, 600V, UFR
D4	1	T12705-23	DIODE, SCHOTTKY, AXLDS, 1A, 30V, 1N5818
D5	1	T12705-34	DIODE, AXLDS, 1A, 400V, FR, 1N4936
DZ4	1	T12702-25	ZENER DIODE, 5W, 20V, 5% 1N5357B
DZ5, DZ6	2	T12702-45	ZENER DIODE, 1W, 18V, 5% 1N4746A
J46	1	S24020-4	CONNECTOR, MOLEX, MINI, PCB, 4-PIN, TIN
J47	1	S24020-8	CONNECTOR, MOLEX, MINI, PCB, 8-PIN, TIN
L1	1	T12218-16	CHOKE, HIGH-CURRENT, 100UH, 10A, 10%, LOW PROFILE
LED1	1	T13657-2	LED, T-1, 3/4, RED, HLMP-3003
MOV1	1	T13640-15K	MOV, 50V RMS, 15J, 14MM
R3, R4, R5, R7, R8	5	S19400-1002	RESISTOR, MF, 1/4W, 10.0K, 1%
R9, R10, R11	3	S19400-8251	RESISTOR, MF, 1/4W, 8.25K, 1%
R12, R13	2	S19400-1000	RESISTOR, MF, 1/4W, 100, 1%
R14, R22	2	S19400-1821	RESISTOR, MF, 1/4W, 1.82K, 1%
R15, R16	2	S19400-47R5	RESISTOR, MF, 1/4W, 47.5, 1%
R19	1	S19400-5622	RESISTOR, MF, 1/4W, 56.2K, 1%
R20, R21	2	S19400-2672	RESISTOR, MF, 1/4W, 26.7K, 1%
R23	1	S19400-2213	RESISTOR, MF, 1/4W, 221K, 1%
R25	1	T14648-17	RESISTOR, WW, 5W, 270, 5%, SQ
R26, R27	2	T12300-86	RESISTOR, WW, 3W, 0.05, 1%
R28	1	S19400-4752	RESISTOR, MF, 1/4W, 47.5K, 1%
R29	1	S19400-3323	RESISTOR, MF, 1/4W, 332K, 1%
N.A. X1	1	M15458-4	IC, PWM-CONTROLLER, I, MODE, 2842A
N.A. X2	1	S15018-16	IC, CMOS, DRIVER, MOSFET, 2110(SS)

CAPACITOR = MFD/VOLTS
RESISTORS = OHMS, 1/4 WATT (UNLESS OTHERSIDE SPECIFIED)

ITEM	REQ'D	PART NO.	DESCRIPTION
1	1	SEE BLANK INFO.	P.C. BOARD BLANK
3	100 g.	E2527	EPOXY ENCAPSULATION RESIN
4	.75 oz.	E2861	SEALANT

N.A. CAUTION: THIS DEVICE IS SUBJECT TO DAMAGE BY STATIC ELECTRICITY. SEE E2454 BEFORE HANDLING.

N.B. COVER EXPOSED BOTTOM SURFACE OF ELECTRONIC MODULE TO AVOID POTTING MATERIAL BUILD UP.

N.C. MOLEX CAVITIES AND AREA AROUND TAB TO BE FREE OF POTTING MATERIAL. MASK PER APPROPRIATE MANUFACTURING WORK INSTRUCTIONS.

N.D. ELECTRONIC MODULES TO BE ASSEMBLED AND ENCAPSULATED PER E3875.

N.E. COMPLETELY COVER EXPOSED LEADS AND BODY OF R25 RESISTOR WITH **ITEM 4** SEALANT.

N.F. COVER EXPOSED LEADS OF C15 CAPACITOR WITH **ITEM 4** SEALANT.

ALL COMPONENTS AND MATERIALS USED IN THIS ASSEMBLY ARE TO BE RoHS COMPLIANT PER E4253.

FOR PARTS ORDERS ONLY:
INCLUDE (1) S25191PRINT AND (1) T12837-1

PROPRIETARY & CONFIDENTIAL: THIS DOCUMENT CONTAINS PROPRIETARY INFORMATION OWNED BY LINCOLN GLOBAL, INC. AND MAY NOT BE DUPLICATED, COMMUNICATED TO OTHER PARTIES OR USED FOR ANY PURPOSE WITHOUT THE EXPRESS WRITTEN PERMISSION OF LINCOLN GLOBAL, INC.			
<small>UNLESS OTHERWISE SPECIFIED TOLERANCE MANUFACTURING TOLERANCE PER E2056 ON 2 PLACE DECIMALS IS ± .02 ON 3 PLACE DECIMALS IS ± .002 ON ALL ANGLES IS ± 5 OF A DEGREE MATERIAL TOLERANCE ("1") TO AGREE WITH PUBLISHED STANDARDS DO NOT SCALE THIS DRAWING</small>	DESIGN INFORMATION DRAWN BY: FEI ENGINEER: APPROVED:	REFERENCE L11078-1 SCALE: NONE	EQUIPMENT TYPE: MULTI-WELD 350 SUBJECT: 40V DC BUS P.C. BOARD ASSEMBLY MATERIAL DISPOSITION: UF APPROVAL DATE: 4/5/2007 PROJECT NUMBER: CRM38610
			PAGE 1 OF 1 DOCUMENT NUMBER: L11078-2 DOCUMENT REVISION: C

NOTE: Lincoln Electric assumes no responsibility for liabilities resulting from board level troubleshooting. PC Board repairs will invalidate your factory warranty. **Individual Printed Circuit Board Components are not available from Lincoln Electric.** This information is provided for reference only. Lincoln Electric discourages board level troubleshooting and repair since it may compromise the quality of the design and may result in danger to the Machine Operator or Technician. Improper PC board repairs could result in damage to the machine.

SCHEMATIC - ANALOG POWER PRINTED CIRCUIT BOARD - ALL CODES (M19422-1)

Return to Section TOC
Return to Master TOC

Return to Section TOC
Return to Master TOC

Return to Section TOC
Return to Master TOC

Return to Section TOC
Return to Master TOC

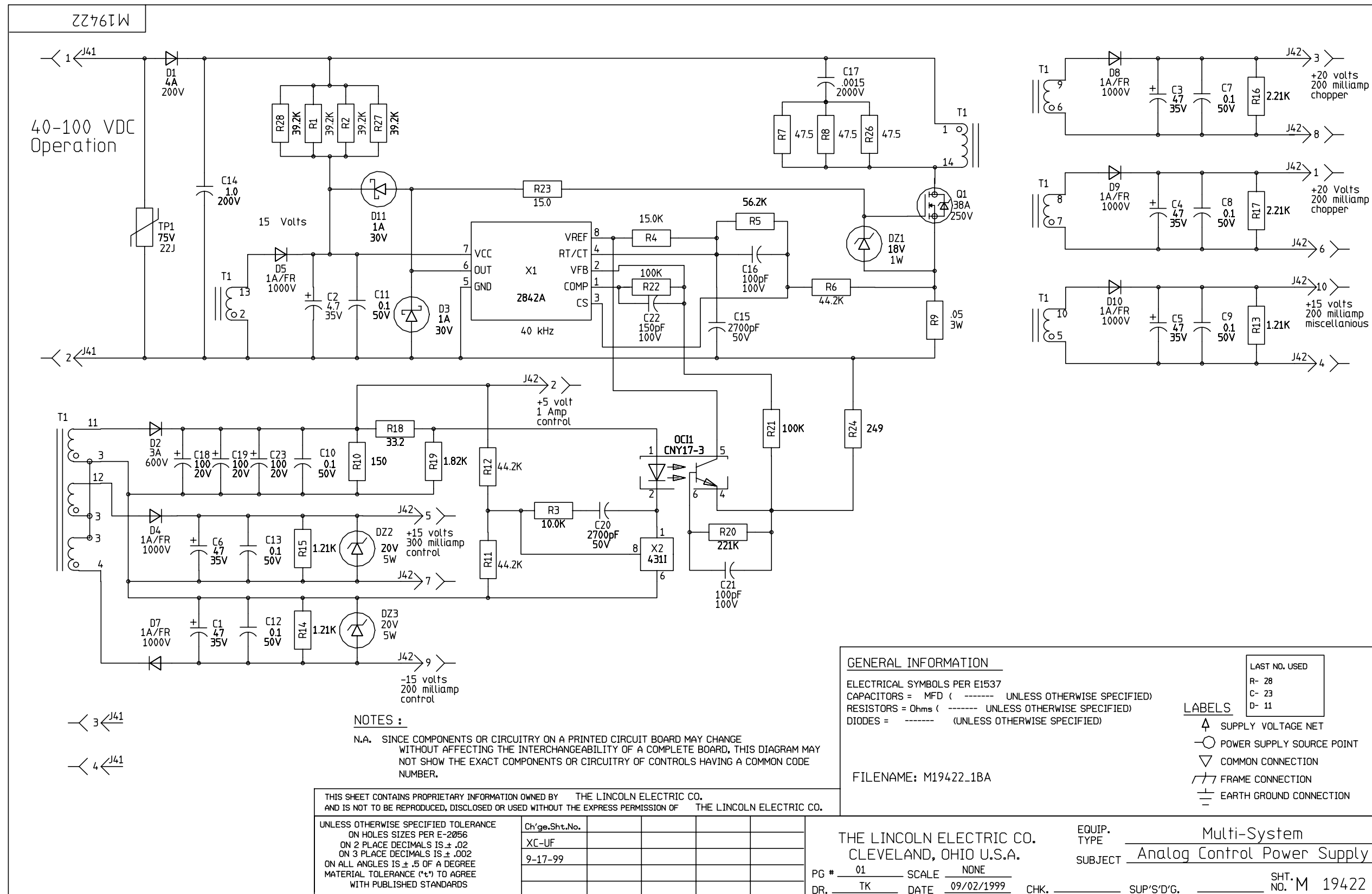

NOTE: This diagram is for reference only. It may not be accurate for all machines covered by this manual.

SCHEMATIC - BY-PASS PRINTED CIRCUIT BOARD - ALL CODES (S24726)

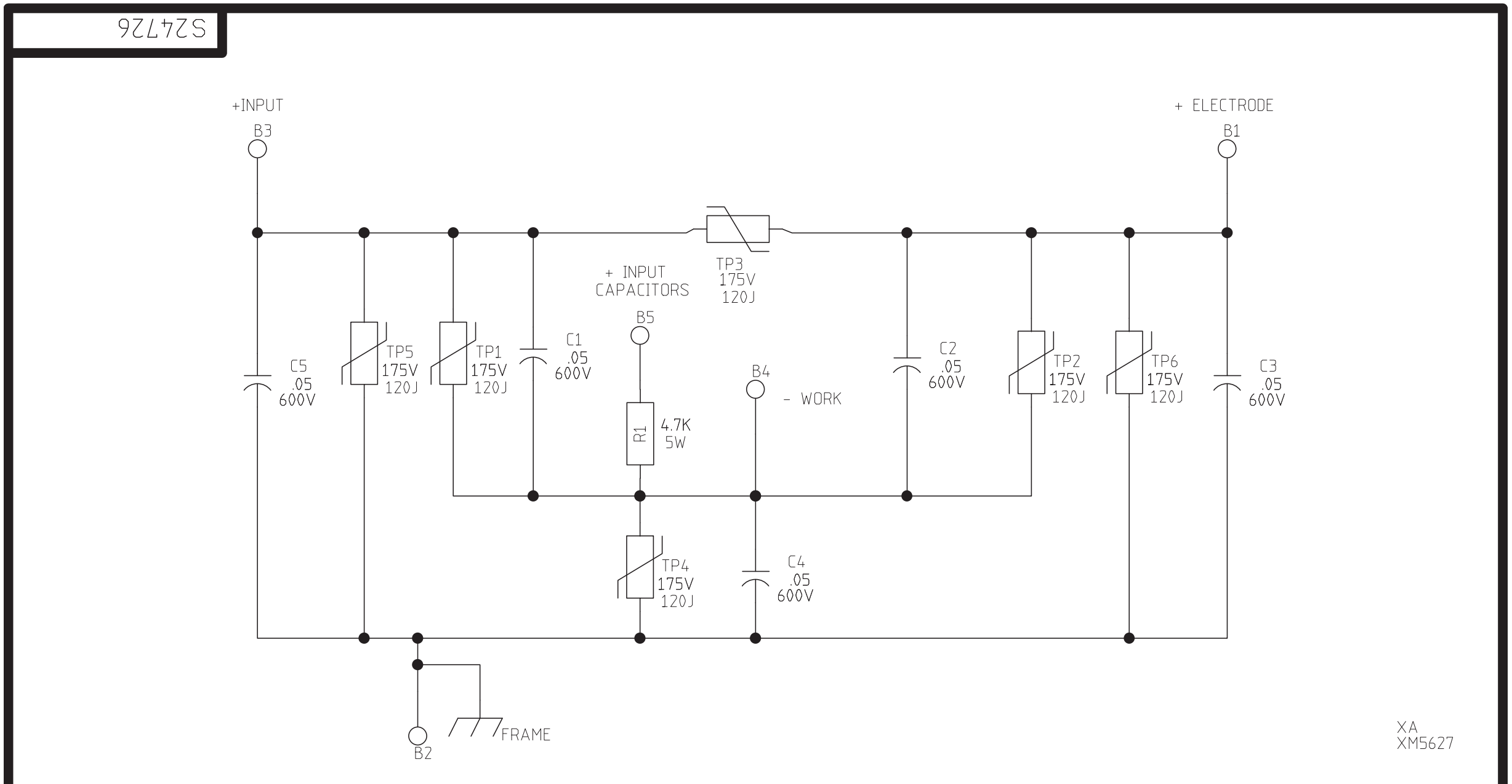

XA XM5627

THIS SHEET CONTAINS PROPRIETARY INFORMATION OWNED BY THE LINCOLN ELECTRIC CO. AND IS NOT TO BE REPRODUCED, DISCLOSED OR USED WITHOUT THE EXPRESS PERMISSION OF THE LINCOLN ELECTRIC CO. CLEVELAND, OHIO U.S.A.

NOTES :

N.A. SINCE COMPONENTS OR CIRCUITRY ON A PRINTED CIRCUIT BOARD MAY CHANGE WITHOUT AFFECTING THE INTERCHANGEABILITY OF A COMPLETE BOARD. THIS DIAGRAM MAY NOT SHOW THE EXACT COMPONENTS OR CIRCUITRY OF CONTROLS HAVING A COMMON CODE NUMBER.

GENERAL INFORMATION

ELECTRICAL SYMBOLS PER E1537
CAPACITORS = MFD (----- UNLESS OTHERWISE SPECIFIED)
RESISTORS = Ohms (----- UNLESS OTHERWISE SPECIFIED)
DIODES = ----- (UNLESS OTHERWISE SPECIFIED)

LABELS

▲ SUPPLY VOLTAGE NET
○ POWER SUPPLY SOURCE POINT
▽ COMMON CONNECTION
▭ FRAME CONNECTION
≡ EARTH GROUND CONNECTION

LAST NO. USED

R- 1
C- 5
D- -

FILENAME: S24726_1AA

UNLESS OTHERWISE SPECIFIED TOLERANCE
ON HOLES SIZES PER E2056
ON 2 PLACE DECIMALS IS ± .02
ON 3 PLACE DECIMALS IS ± .002
ON ALL ANGLES IS ± .5 OF A DEGREE
MATERIAL TOLERANCE ("t") TO AGREE
WITH PUBLISHED STANDARDS

DO NOT SCALE THIS DRAWING

Chg. Sheet No.	*X* INFO	DESIGN INFORMATION
	XM5627	DRAWN BY: RLS
	XA	ENGINEER: APM
		REVISED BY: ---

EQUIPMENT TYPE:	Multi Weld 350
SUBJECT:	By-Pass PC Board Assembly
DATE: 05/06/99	SCALE: NONE REF.: -----
DRWG. NO. S24726X	

NOTE: This diagram is for reference only. It may not be accurate for all machines covered by this manual.

Return to Section TOC
Return to Section TOC
Return to Section TOC
Return to Section TOC
Return to Section TOC
Return to Section TOC

PC BOARD ASSEMBLY - BY-PASS - ALL CODES (M19510-1)

Return to Section TOC
Return to Section TOC
Return to Section TOC
Return to Section TOC
Return to Section TOC
Return to Section TOC
Return to Section TOC
Return to Section TOC

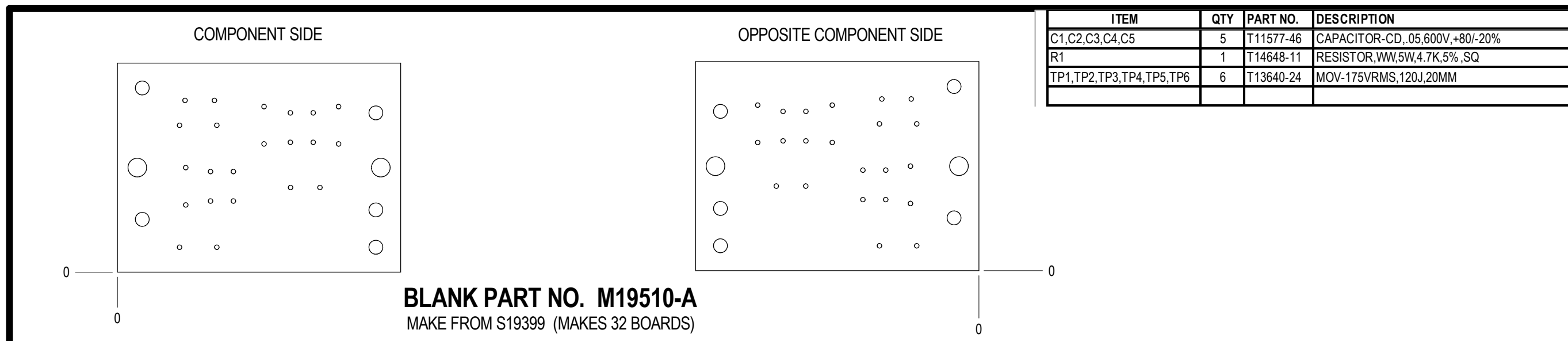

ITEM	QTY	PART NO.	DESCRIPTION
C1,C2,C3,C4,C5	5	T11577-46	CAPACITOR-CD..05,600V,+80/-20%
R1	1	T14648-11	RESISTOR,VW,5W,4.7K,5%,SQ
TP1,TP2,TP3,TP4,TP5,TP6	6	T13640-24	MOV-175VRMS,120J,20MM

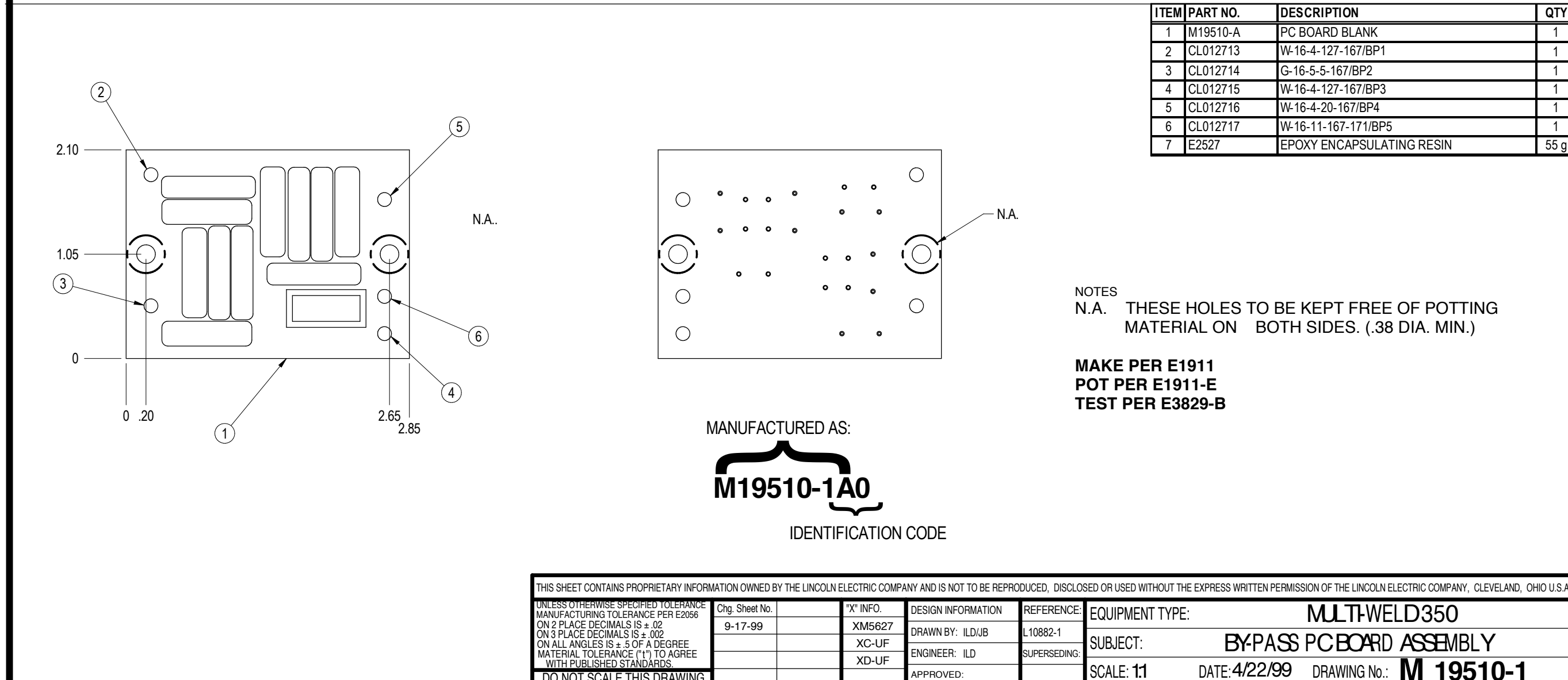

ITEM	PART NO.	DESCRIPTION	QTY
1	M19510-A	PC BOARD BLANK	1
2	CL012713	W-16-4-127-167/BP1	1
3	CL012714	G-16-5-5-167/BP2	1
4	CL012715	W-16-4-127-167/BP3	1
5	CL012716	W-16-4-20-167/BP4	1
6	CL012717	W-16-11-167-171/BP5	1
7	E2527	EPOXY ENCAPSULATING RESIN	55 g

NOTES
N.A. THESE HOLES TO BE KEPT FREE OF POTTING MATERIAL ON BOTH SIDES. (.38 DIA. MIN.)

MAKE PER E1911
POT PER E1911-E
TEST PER E3829-B

THIS SHEET CONTAINS PROPRIETARY INFORMATION OWNED BY THE LINCOLN ELECTRIC COMPANY AND IS NOT TO BE REPRODUCED, DISCLOSED OR USED WITHOUT THE EXPRESS WRITTEN PERMISSION OF THE LINCOLN ELECTRIC COMPANY, CLEVELAND, OHIO U.S.A.						
UNLESS OTHERWISE SPECIFIED TOLERANCE MANUFACTURING TOLERANCE PER E2056 ON 2 PLACE DECIMALS IS ± .02 ON 3 PLACE DECIMALS IS ± .002 ON ALL ANGLES IS ± .5 OF A DEGREE MATERIAL TOLERANCE ("I") TO AGREE WITH PUBLISHED STANDARDS. DO NOT SCALE THIS DRAWING	Chg. Sheet No.	"X" INFO.	DESIGN INFORMATION	REFERENCE:	EQUIPMENT TYPE: MULTI-WELD350	
	9-17-99	XM5627	DRAWN BY: ILD/JB	L10882-1	SUBJECT: BY-PASS PC BOARD ASSEMBLY	
		XC-UF	ENGINEER: ILD	SUPERSEDING:	SCALE: 1:1 DATE: 4/22/99 DRAWING No.: M 19510-1	
		XD-UF	APPROVED:			

NOTE: Lincoln Electric assumes no responsibility for liabilities resulting from board level troubleshooting. PC Board repairs will invalidate your factory warranty. **Individual Printed Circuit Board Components are not available from Lincoln Electric.** This information is provided for reference only. Lincoln Electric discourages board level troubleshooting and repair since it may compromise the quality of the design and may result in danger to the Machine Operator or Technician. Improper PC board repairs could result in damage to the machine.



SCHEMATIC - CHOPPER PRINTED CIRCUIT BOARD - ALL CODES (M19303)

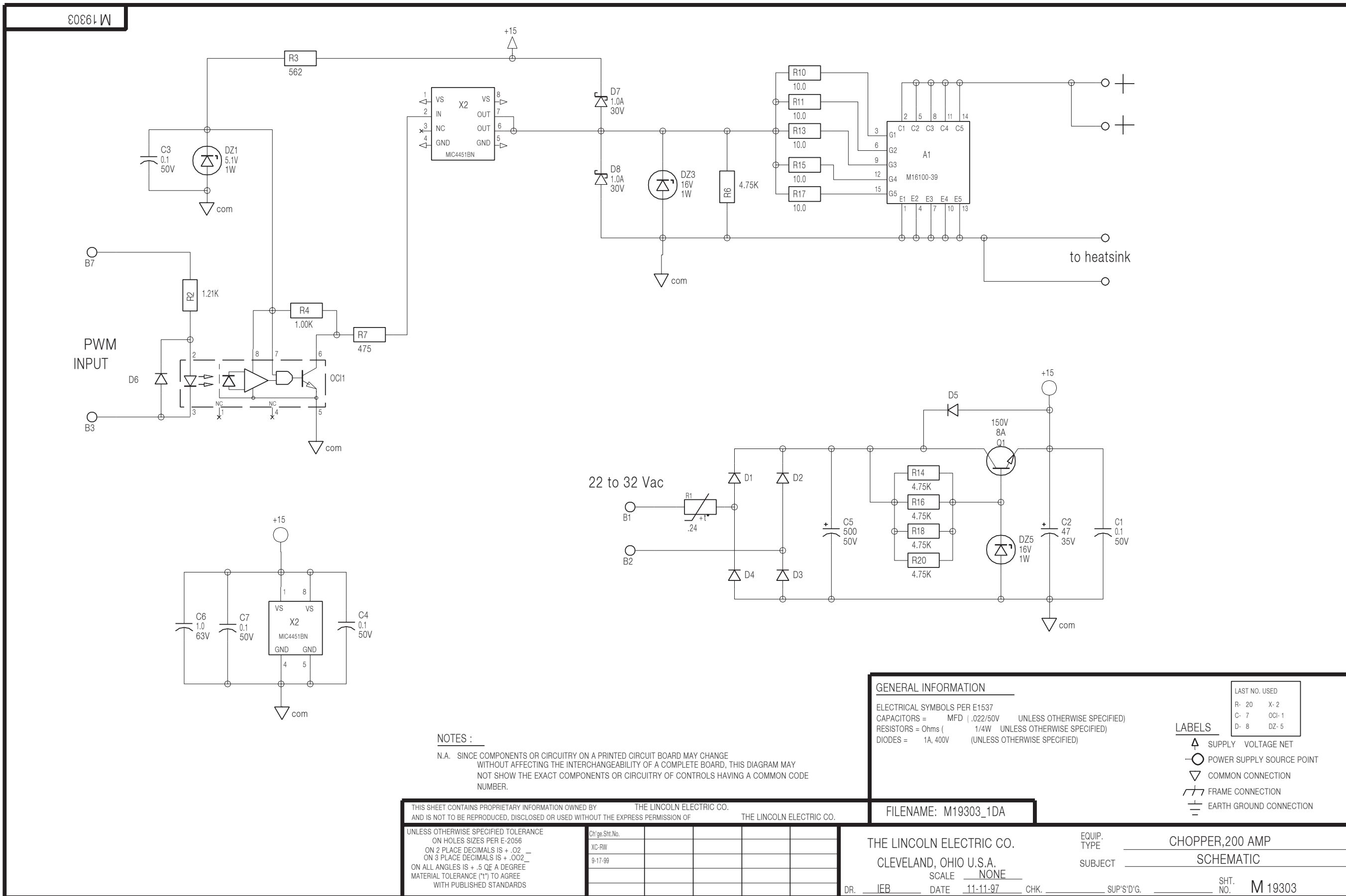

NOTES :
 N.A. SINCE COMPONENTS OR CIRCUITRY ON A PRINTED CIRCUIT BOARD MAY CHANGE WITHOUT AFFECTING THE INTERCHANGEABILITY OF A COMPLETE BOARD, THIS DIAGRAM MAY NOT SHOW THE EXACT COMPONENTS OR CIRCUITRY OF CONTROLS HAVING A COMMON CODE NUMBER.

GENERAL INFORMATION
 ELECTRICAL SYMBOLS PER E1537
 CAPACITORS = MFD (.022/50V UNLESS OTHERWISE SPECIFIED)
 RESISTORS = Ohms (1/4W UNLESS OTHERWISE SPECIFIED)
 DIODES = 1A, 400V (UNLESS OTHERWISE SPECIFIED)

LABELS

▲	SUPPLY VOLTAGE NET
○	POWER SUPPLY SOURCE POINT
▽	COMMON CONNECTION
⎓	FRAME CONNECTION
⊥	EARTH GROUND CONNECTION

LAST NO. USED

R- 20	X- 2
C- 7	OCI- 1
D- 8	DZ- 5

THIS SHEET CONTAINS PROPRIETARY INFORMATION OWNED BY THE LINCOLN ELECTRIC CO. AND IS NOT TO BE REPRODUCED, DISCLOSED OR USED WITHOUT THE EXPRESS PERMISSION OF THE LINCOLN ELECTRIC CO.

UNLESS OTHERWISE SPECIFIED TOLERANCE
 ON HOLES SIZES PER E-2056
 ON 2 PLACE DECIMALS IS + .02
 ON 3 PLACE DECIMALS IS + .002
 ON ALL ANGLES IS + .5 OF A DEGREE
 MATERIAL TOLERANCE (*) TO AGREE WITH PUBLISHED STANDARDS

Ch'ge Sht. No.	
XC-RW	
9-17-99	

FILENAME: M19303_1DA

THE LINCOLN ELECTRIC CO.
 CLEVELAND, OHIO U.S.A.
 SCALE NONE

EQUIP. TYPE CHOPPER, 200 AMP
 SUBJECT SCHEMATIC

DR. JEB DATE 11-11-97 CHK. SUP'S'D'G. SHT. NO. M 19303

NOTE: This diagram is for reference only. It may not be accurate for all machines covered by this manual.

PC BOARD ASSEMBLY - CHOPPER - ALL CODES (L11038-1)

Return to Section TOC
Return to Master TOC

Return to Section TOC
Return to Master TOC

Return to Section TOC
Return to Master TOC

Return to Section TOC
Return to Master TOC

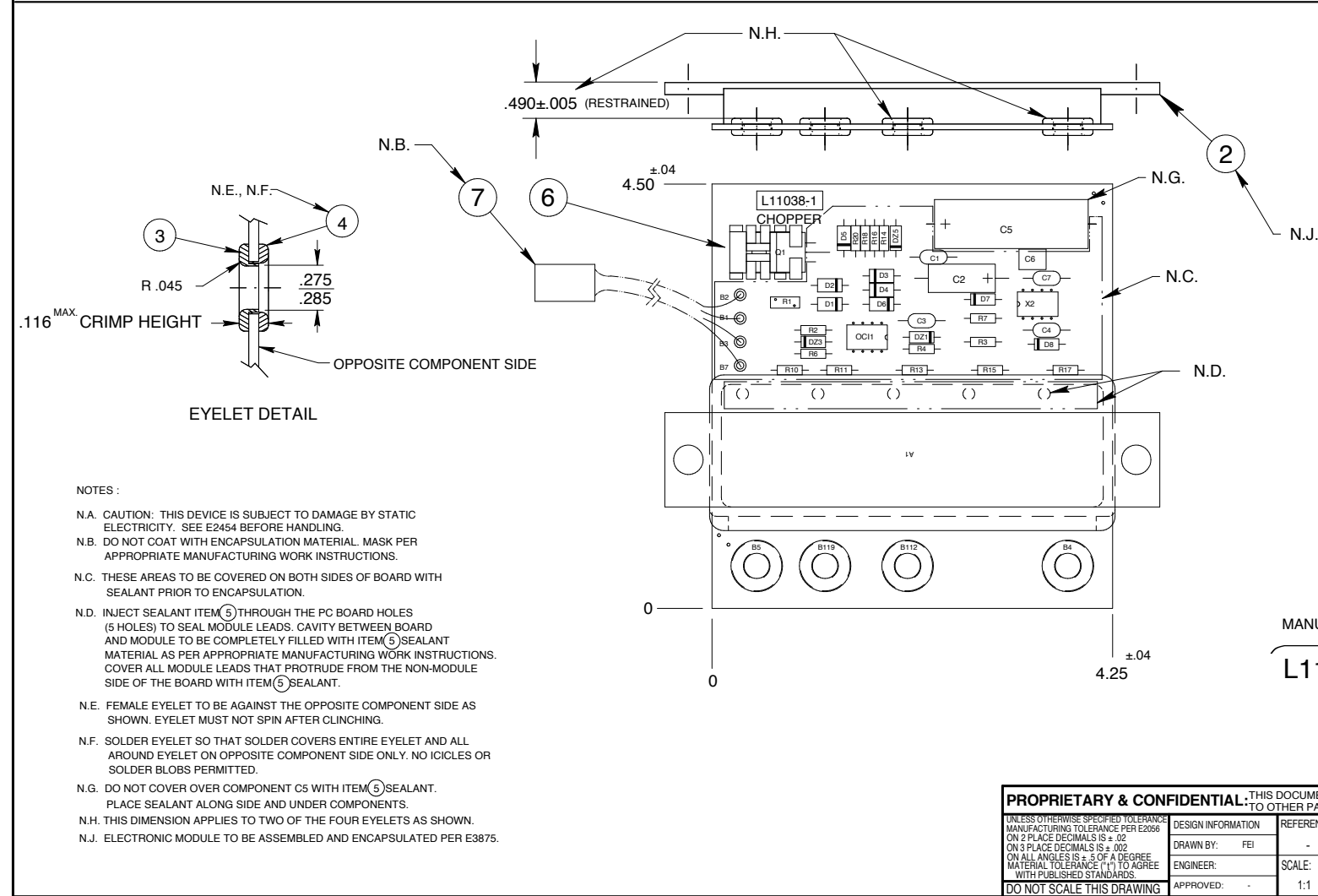
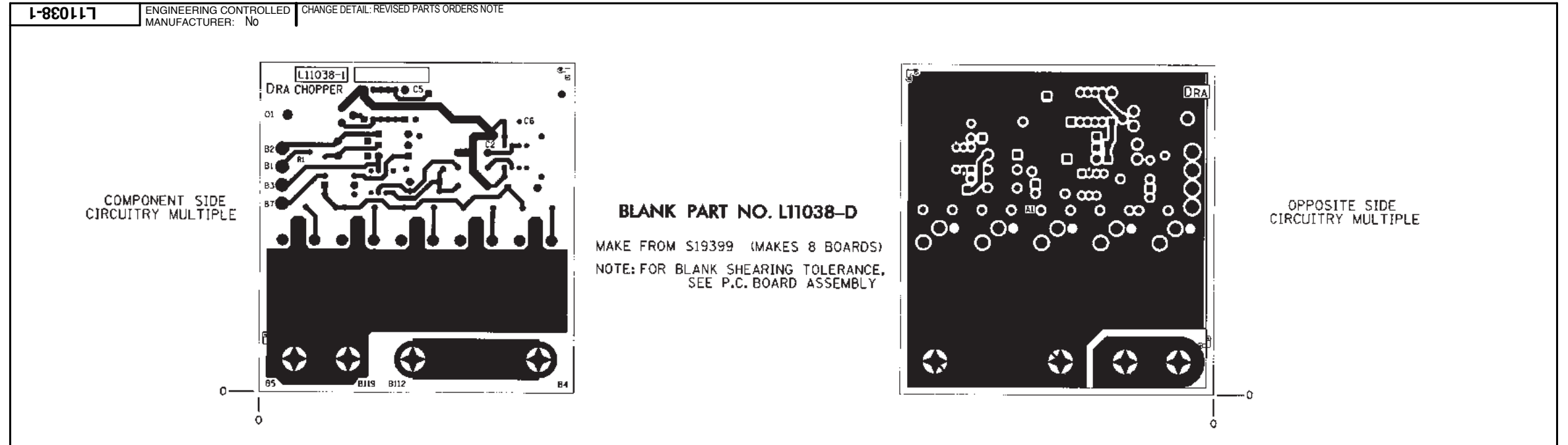

ITEM	REQ'D	PART NO	IDENTIFICATION
C1,C3,C4,C7	4	S16668-11	.1/50
C2	1	S13490-66	47/35
C5	1	T11577-49	500/50
C6	1	S13490-173	CAPACITOR,MPF,1.0 uF,63VDC
D1,D2,D3,D4,D5,D6	6	T12199-1	1N4004
D7,D8	2	T12705-23	1N5818
DZ1	1	T12702-52	1N4733A
DZ3,DZ5	2	T12702-11	1N4745A
OC11	1	S15000-28	OPTOCOUPLER,TTL-OUT
Q1	1	T12704-41	??USE H.S. S20590-1??
R1	1	S18380-5	THERMISTOR,PTC,0.5-1.17 OHMS,0.5A
R2	1	S19400-1211	1.21K 1/4W
R3	1	S19400-5620	562 1/4W
R4	1	S19400-1001	1K 1/4W
R6,R14,R16,R18,R20	5	S19400-4751	4.75K
R7	1	S19400-4750	475 1/4W
R10,R11,R13,R15,R17	5	S19400-10R0	10 1/4W
X2	1	S15018-21	IC,DRIVER,9A,LOW-SIDE MOSFET (SS)

ITEM	REQ'D	PART NO.	IDENTIFICATION
1	1	L11038-D	P.C. BOARD BLANK
2	1	M16100-39	ELECTRONIC MODULE (A1)
3	4	T9147-15	EYELETS (MALE) (B4,B5,B112,B119)
4	4	T9147-11	EYELETS (FEMALE)
5	2.0 OZ.	E2861	SEALANT
6	1	S20590-1	HEAT SINK
7	1	S18250-542	PLUG & LEAD ASSEMBLY

MAKE PER E1911
 ENCAPSULATE WITH E1844
 TEST PER E3827-CH
 SCHEMATIC REFERENCE: M19303

MANUFACTURED AS:
L11038-1D0

IDENTIFICATION CODE

FOR PARTS ORDERS: INCLUDE
 (1) S25191-1PRINT
 (1) S25347-2 INTERFACE PAD
 (1) T12837-1 JOINT COMPOUND

PROPRIETARY & CONFIDENTIAL - THIS DOCUMENT CONTAINS PROPRIETARY INFORMATION OWNED BY LINCOLN GLOBAL, INC. AND MAY NOT BE DUPLICATED, COMMUNICATED TO OTHER PARTIES OR USED FOR ANY PURPOSE WITHOUT THE EXPRESS WRITTEN PERMISSION OF LINCOLN GLOBAL, INC.		DESIGN INFORMATION	REFERENCE:	EQUIPMENT TYPE:	ENGINE WELDERS	PAGE 1 OF 1
UNLESS OTHERWISE SPECIFIED TOLERANCE MANUFACTURING TOLERANCE PER E2056 ON 2 PLACE DECIMALS IS ± .02 ON 3 PLACE DECIMALS IS ± .002 ON ALL ANGLES IS ± 5 OF A DEGREE MATERIAL TOLERANCE (1) TO AGREE WITH PUBLISHED STANDARDS DO NOT SCALE THIS DRAWING	DRAWN BY: FEI	SCALE:	1:1	SUBJECT:	CHOPPER P.C. BOARD ASSEMBLY	DOCUMENT NUMBER: L11038-1
	ENGINEER:	APPROVAL DATE:	12/05/2002	MATERIAL DISPOSITION:	UJ	PROJECT NUMBER: CM35325
	APPROVED:					DOCUMENT REVISION: B

NOTE: Lincoln Electric assumes no responsibility for liabilities resulting from board level troubleshooting. PC Board repairs will invalidate your factory warranty. **Individual Printed Circuit Board Components are not available from Lincoln Electric.** This information is provided for reference only. Lincoln Electric discourages board level troubleshooting and repair since it may compromise the quality of the design and may result in danger to the Machine Operator or Technician. Improper PC board repairs could result in damage to the machine.