



NOTE: This manual will cover most of the troubleshooting and repair procedures for the code numbers listed. Some variances may exist when troubleshooting/repairing later code numbers.

CLASSIC III/IIID GASOLINE & DIESEL ENGINE DRIVEN DC ARC WELDING POWER SOURCE

For use with machines having Code Numbers:

10033, 10061, 10072 or 10156.

SERVICE MANUAL



⚠ WARNING

⚠ CALIFORNIA PROPOSITION 65 WARNINGS ⚠

Diesel engine exhaust and some of its constituents are known to the State of California to cause cancer, birth defects, and other reproductive harm.

The Above For Diesel Engines

The engine exhaust from this product contains chemicals known to the State of California to cause cancer, birth defects, or other reproductive harm.

The Above For Gasoline Engines

ARC WELDING CAN BE HAZARDOUS. PROTECT YOURSELF AND OTHERS FROM POSSIBLE SERIOUS INJURY OR DEATH. KEEP CHILDREN AWAY. PACEMAKER WEARERS SHOULD CONSULT WITH THEIR DOCTOR BEFORE OPERATING.

Read and understand the following safety highlights. For additional safety information, it is strongly recommended that you purchase a copy of "Safety in Welding & Cutting - ANSI Standard Z49.1" from the American Welding Society, P.O. Box 351040, Miami, Florida 33135 or CSA Standard W117.2-1974. A Free copy of "Arc Welding Safety" booklet E205 is available from the Lincoln Electric Company, 22801 St. Clair Avenue, Cleveland, Ohio 44117-1199.

BE SURE THAT ALL INSTALLATION, OPERATION, MAINTENANCE AND REPAIR PROCEDURES ARE PERFORMED ONLY BY QUALIFIED INDIVIDUALS.



FOR ENGINE powered equipment.

1.a. Turn the engine off before troubleshooting and maintenance work unless the maintenance work requires it to be running.



1.b. Operate engines in open, well-ventilated areas or vent the engine exhaust fumes outdoors.



1.c. Do not add the fuel near an open flame welding arc or when the engine is running. Stop the engine and allow it to cool before refueling to prevent spilled fuel from vaporizing on contact with hot engine parts and igniting. Do not spill fuel when filling tank. If fuel is spilled, wipe it up and do not start engine until fumes have been eliminated.



1.d. Keep all equipment safety guards, covers and devices in position and in good repair. Keep hands, hair, clothing and tools away from V-belts, gears, fans and all other moving parts when starting, operating or repairing equipment.

1.e. In some cases it may be necessary to remove safety guards to perform required maintenance. Remove guards only when necessary and replace them when the maintenance requiring their removal is complete. Always use the greatest care when working near moving parts.

1.f. Do not put your hands near the engine fan. Do not attempt to override the governor or idler by pushing on the throttle control rods while the engine is running.

1.g. To prevent accidentally starting gasoline engines while turning the engine or welding generator during maintenance work, disconnect the spark plug wires, distributor cap or magneto wire as appropriate.



1.h. To avoid scalding, do not remove the radiator pressure cap when the engine is hot.



ELECTRIC AND MAGNETIC FIELDS may be dangerous

2.a. Electric current flowing through any conductor causes localized Electric and Magnetic Fields (EMF). Welding current creates EMF fields around welding cables and welding machines

2.b. EMF fields may interfere with some pacemakers, and welders having a pacemaker should consult their physician before welding.

2.c. Exposure to EMF fields in welding may have other health effects which are now not known.

2.d. All welders should use the following procedures in order to minimize exposure to EMF fields from the welding circuit:

2.d.1. Route the electrode and work cables together - Secure them with tape when possible.

2.d.2. Never coil the electrode lead around your body.

2.d.3. Do not place your body between the electrode and work cables. If the electrode cable is on your right side, the work cable should also be on your right side.

2.d.4. Connect the work cable to the workpiece as close as possible to the area being welded.

2.d.5. Do not work next to welding power source.

Mar '95

Classic III and IIID





ELECTRIC SHOCK can kill.

3.a. The electrode and work (or ground) circuits are electrically “hot” when the welder is on. Do not touch these “hot” parts with your bare skin or wet clothing. Wear dry, hole-free gloves to insulate hands.

3.b. Insulate yourself from work and ground using dry insulation. Make certain the insulation is large enough to cover your full area of physical contact with work and ground.

In addition to the normal safety precautions, if welding must be performed under electrically hazardous conditions (in damp locations or while wearing wet clothing; on metal structures such as floors, gratings or scaffolds; when in cramped positions such as sitting, kneeling or lying, if there is a high risk of unavoidable or accidental contact with the workpiece or ground) use the following equipment:

- Semiautomatic DC Constant Voltage (Wire) Welder.
- DC Manual (Stick) Welder.
- AC Welder with Reduced Voltage Control.

3.c. In semiautomatic or automatic wire welding, the electrode, electrode reel, welding head, nozzle or semiautomatic welding gun are also electrically “hot”.

3.d. Always be sure the work cable makes a good electrical connection with the metal being welded. The connection should be as close as possible to the area being welded.

3.e. Ground the work or metal to be welded to a good electrical (earth) ground.

3.f. Maintain the electrode holder, work clamp, welding cable and welding machine in good, safe operating condition. Replace damaged insulation.

3.g. Never dip the electrode in water for cooling.

3.h. Never simultaneously touch electrically “hot” parts of electrode holders connected to two welders because voltage between the two can be the total of the open circuit voltage of both welders.

3.i. When working above floor level, use a safety belt to protect yourself from a fall should you get a shock.

3.j. Also see Items 6.c. and 8.



ARC RAYS can burn.

4.a. Use a shield with the proper filter and cover plates to protect your eyes from sparks and the rays of the arc when welding or observing open arc welding. Headshield and filter lens should conform to ANSI Z87.1 standards.

4.b. Use suitable clothing made from durable flame-resistant material to protect your skin and that of your helpers from the arc rays.

4.c. Protect other nearby personnel with suitable, non-flammable screening and/or warn them not to watch the arc nor expose themselves to the arc rays or to hot spatter or metal.



FUMES AND GASES can be dangerous.

5.a. Welding may produce fumes and gases hazardous to health. Avoid breathing these fumes and gases. When welding, keep your head out of the fume. Use enough ventilation and/or exhaust at the arc to keep fumes and gases away from the breathing zone. **When welding with electrodes which require special ventilation such as stainless or hard facing (see instructions on container or MSDS) or on lead or cadmium plated steel and other metals or coatings which produce highly toxic fumes, keep exposure as low as possible and below Threshold Limit Values (TLV) using local exhaust or mechanical ventilation. In confined spaces or in some circumstances, outdoors, a respirator may be required. Additional precautions are also required when welding on galvanized steel.**

5.b. Do not weld in locations near chlorinated hydrocarbon vapors coming from degreasing, cleaning or spraying operations. The heat and rays of the arc can react with solvent vapors to form phosgene, a highly toxic gas, and other irritating products.

5.c. Shielding gases used for arc welding can displace air and cause injury or death. Always use enough ventilation, especially in confined areas, to insure breathing air is safe.

5.d. Read and understand the manufacturer's instructions for this equipment and the consumables to be used, including the material safety data sheet (MSDS) and follow your employer's safety practices. MSDS forms are available from your welding distributor or from the manufacturer.

5.e. Also see item 1.b.

Mar '95

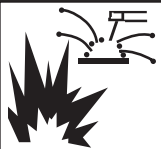

WELDING SPARKS can cause fire or explosion.

6.a. Remove fire hazards from the welding area.

If this is not possible, cover them to prevent the welding sparks from starting a fire.

Remember that welding sparks and hot materials from welding can easily go through small cracks and openings to adjacent areas. Avoid welding near hydraulic lines. Have a fire extinguisher readily available.

6.b. Where compressed gases are to be used at the job site, special precautions should be used to prevent hazardous situations. Refer to "Safety in Welding and Cutting" (ANSI Standard Z49.1) and the operating information for the equipment being used.

6.c. When not welding, make certain no part of the electrode circuit is touching the work or ground. Accidental contact can cause overheating and create a fire hazard.

6.d. Do not heat, cut or weld tanks, drums or containers until the proper steps have been taken to insure that such procedures will not cause flammable or toxic vapors from substances inside. They can cause an explosion even though they have been "cleaned". For information, purchase "Recommended Safe Practices for the Preparation for Welding and Cutting of Containers and Piping That Have Held Hazardous Substances", AWS F4.1 from the American Welding Society (see address above).

6.e. Vent hollow castings or containers before heating, cutting or welding. They may explode.

6.f. Sparks and spatter are thrown from the welding arc. Wear oil free protective garments such as leather gloves, heavy shirt, cuffless trousers, high shoes and a cap over your hair. Wear ear plugs when welding out of position or in confined places. Always wear safety glasses with side shields when in a welding area.

6.g. Connect the work cable to the work as close to the welding area as practical. Work cables connected to the building framework or other locations away from the welding area increase the possibility of the welding current passing through lifting chains, crane cables or other alternate circuits. This can create fire hazards or overheat lifting chains or cables until they fail.

6.h. Also see item 1.c.



CYLINDER may explode if damaged.

7.a. Use only compressed gas cylinders containing the correct shielding gas for the process used and properly operating regulators designed for the gas and pressure used. All hoses, fittings, etc. should be suitable for the application and maintained in good condition.

7.b. Always keep cylinders in an upright position securely chained to an undercarriage or fixed support.

7.c. Cylinders should be located:

- Away from areas where they may be struck or subjected to physical damage.
- A safe distance from arc welding or cutting operations and any other source of heat, sparks, or flame.

7.d. Never allow the electrode, electrode holder or any other electrically "hot" parts to touch a cylinder.

7.e. Keep your head and face away from the cylinder valve outlet when opening the cylinder valve.

7.f. Valve protection caps should always be in place and hand tight except when the cylinder is in use or connected for use.

7.g. Read and follow the instructions on compressed gas cylinders, associated equipment, and CGA publication P-1, "Precautions for Safe Handling of Compressed Gases in Cylinders," available from the Compressed Gas Association 1235 Jefferson Davis Highway, Arlington, VA 22202.



FOR ELECTRICALLY powered equipment.

8.a. Turn off input power using the disconnect switch at the fuse box before working on the equipment.

8.b. Install equipment in accordance with the U.S. National Electrical Code, all local codes and the manufacturer's recommendations.

8.c. Ground the equipment in accordance with the U.S. National Electrical Code and the manufacturer's recommendations.

Mar '95

PRÉCAUTIONS DE SÛRETÉ

Pour votre propre protection lire et observer toutes les instructions et les précautions de sûreté spécifiques qui paraissent dans ce manuel aussi bien que les précautions de sûreté générales suivantes:

Sûreté Pour Soudage A L'Arc

1. Protégez-vous contre la secousse électrique:
 - a. Les circuits à l'électrode et à la pièce sont sous tension quand la machine à souder est en marche. Eviter toujours tout contact entre les parties sous tension et la peau nue ou les vêtements mouillés. Porter des gants secs et sans trous pour isoler les mains.
 - b. Faire très attention de bien s'isoler de la masse quand on soude dans des endroits humides, ou sur un plancher métallique ou des grilles métalliques, principalement dans les positions assis ou couché pour lesquelles une grande partie du corps peut être en contact avec la masse.
 - c. Maintenir le porte-électrode, la pince de masse, le câble de soudage et la machine à souder en bon et sûr état de fonctionnement.
 - d. Ne jamais plonger le porte-électrode dans l'eau pour le refroidir.
 - e. Ne jamais toucher simultanément les parties sous tension des porte-électrodes connectés à deux machines à souder parce que la tension entre les deux pinces peut être le total de la tension à vide des deux machines.
 - f. Si on utilise la machine à souder comme une source de courant pour soudage semi-automatique, ces précautions pour le porte-électrode s'appliquent aussi au pistolet de soudage.
2. Dans le cas de travail au dessus du niveau du sol, se protéger contre les chutes dans le cas où on recoit un choc. Ne jamais enrouler le câble-électrode autour de n'importe quelle partie du corps.
3. Un coup d'arc peut être plus sévère qu'un coup de soleil, donc:
 - a. Utiliser un bon masque avec un verre filtrant approprié ainsi qu'un verre blanc afin de se protéger les yeux du rayonnement de l'arc et des projections quand on soude ou quand on regarde l'arc.
 - b. Porter des vêtements convenables afin de protéger la peau de soudeur et des aides contre le rayonnement de l'arc.
 - c. Protéger l'autre personnel travaillant à proximité au soudage à l'aide d'écrans appropriés et non-inflammables.
4. Des gouttes de laitier en fusion sont émises de l'arc de soudage. Se protéger avec des vêtements de protection libres de l'huile, tels que les gants en cuir, chemise épaisse, pantalons sans revers, et chaussures montantes.

5. Toujours porter des lunettes de sécurité dans la zone de soudage. Utiliser des lunettes avec écrans latéraux dans les zones où l'on pique le laitier.
6. Eloigner les matériaux inflammables ou les recouvrir afin de prévenir tout risque d'incendie dû aux étincelles.
7. Quand on ne soude pas, poser la pince à un endroit isolé de la masse. Un court-circuit accidentel peut provoquer un échauffement et un risque d'incendie.
8. S'assurer que la masse est connectée le plus près possible de la zone de travail qu'il est pratique de le faire. Si on place la masse sur la charpente de la construction ou d'autres endroits éloignés de la zone de travail, on augmente le risque de voir passer le courant de soudage par les chaînes de levage, câbles de grue, ou autres circuits. Cela peut provoquer des risques d'incendie ou d'échauffement des chaînes et des câbles jusqu'à ce qu'ils se rompent.
9. Assurer une ventilation suffisante dans la zone de soudage. Ceci est particulièrement important pour le soudage de tôles galvanisées plombées, ou cadmiées ou tout autre métal qui produit des fumées toxiques.
10. Ne pas souder en présence de vapeurs de chlore provenant d'opérations de dégraissage, nettoyage ou pistologie. La chaleur ou les rayons de l'arc peuvent réagir avec les vapeurs du solvant pour produire du phosgène (gas fortement toxique) ou autres produits irritants.
11. Pour obtenir de plus amples renseignements sur la sûreté, voir le code "Code for safety in welding and cutting" CSA Standard W 117.2-1974.

PRÉCAUTIONS DE SÛRETÉ POUR LES MACHINES À SOUDER À TRANSFORMATEUR ET À REDRESSEUR

1. Relier à la terre le chassis du poste conformément au code de l'électricité et aux recommandations du fabricant. Le dispositif de montage ou la pièce à souder doit être branché à une bonne mise à la terre.
2. Autant que possible, l'installation et l'entretien du poste seront effectués par un électricien qualifié.
3. Avant de faire des travaux à l'intérieur de poste, la débrancher à l'interrupteur à la boîte de fusibles.
4. Garder tous les couvercles et dispositifs de sûreté à leur place.

Mar. '93

Classic III and IIID



	Page
Safety	i-iv
<hr/>	
Installation	Section A
Technical Specifications	A-2
Safety Precautions	A-3
Location and Ventilation	A-3
Pre-operation Engine Service	A-4
Electrical Output Connections	A-6
<hr/>	
Operation	Section B
Safety Instructions	B-2
General Description	B-2
Recommended Applications	B-3
Operational Features and Controls	B-3
Design Features	B-3
Welding Capability	B-4
Limitations	B-4
Controls and Settings	B-5
Engine Operation	B-9
Welding Operation	B-11
Auxiliary Power	B-13
<hr/>	
Accessories	Section C
<hr/>	
Maintenance	Section D
Safety Precautions	D-2
Routine and Periodic Maintenance	D-2
Major Component Locations	D-12
<hr/>	
Theory of Operation	Section E
<hr/>	
Troubleshooting and Repair	Section F
<hr/>	
Electrical Diagrams	Section G
<hr/>	
Parts	
Parts List Classic III Diesel	P-232
Parts List Classic III Gas	P-302

TABLE OF CONTENTS - INSTALLATION SECTION -

Installation

Technical Specifications	A-2
Safety Precautions.....	A-3
Location and Ventilation	A-3
Storing	A-3
Stacking.....	A-4
Tilting	A-4
Lifting	A-4
High Altitude Operation.....	A-4
Pre-operation Engine Service.....	A-4
Oil	A-4
Fuel.....	A-4
Battery Connections.....	A-4
Cooling System	A-5
Muffler	A-5
Exhaust Spark Arrester	A-5
Trailer	A-5
Electrical Output Connections.....	A-6
Welding Cable Connections.....	A-6
Cable Installation and Cable Sizes.....	A-6
Machine Grounding.....	A-7
Auxiliary Power Receptacles, Plugs, and Hand-held Equipment.....	A-7
Circuit Breakers	A-7

Return to Master TOC

Return to Master TOC

Return to Master TOC

Return to Master TOC



INSTALLATION

TECHNICAL SPECIFICATIONS - CLASSIC III AND IIID

INPUT - ENGINE					
<u>Manufacturer</u>	<u>Description</u>	<u>Speed</u>	<u>Displacement</u>	<u>Ignition</u>	<u>Capacities</u>
Classic III: Continental TM27	4 cyl., 4 cycle Water-cooled Gasoline 38.9 HP @ 1700 RPM	1725 RPM Full load 1800 RPM High idle	164.7 cu. in. (2700 cc)	Electric	Fuel: 15 gal. (57 liters) Oil: 7 qt. (6.7 liters) Water/coolant: 9.3 qt. (8.8 liters)
Classic IIID: Continental TMD27	4 cyl., 4 cycle Water-cooled Diesel 45 HP @ 1700 RPM	1350 RPM Low idle			
RATED OUTPUT - WELDER					
<u>Duty Cycle</u>	<u>Amps</u>		<u>Volts at Rated Amperes</u>		
100% Duty Cycle 50% Duty Cycle 30% Duty Cycle	225 DC Constant Current 300 DC Constant Current 350 DC Constant Current		29V 32V 34V		
OUTPUT - WELDER AND GENERATOR					
<u>Welding Ranges</u>	<u>Max. Open Circuit Voltage</u>	<u>Auxiliary Power</u>			
40-350 Amps DC	98.5	3.0 kVA of 115/230 V, 60Hz Power 26 Amps @ 115 V ⁽¹⁾ 13 Amps @ 230 V			
PHYSICAL DIMENSIONS					
<u>Height</u>	<u>Width</u>	<u>Depth</u>	<u>Weight</u>		
40.94 in. 1040 mm	24 in. 610 mm	66.25 in. 1683 mm	<u>Classic III</u> 1406 lb. 638 kg	<u>Classic IIID</u> 1445 lb. 657 kg	

¹ 15 amps can be drawn from either half of the receptacle. Total combined load of all receptacles cannot exceed 3.0 kVA.

Classic III and IIID



Return to Section TOC
Return to Master TOC

Return to Section TOC
Return to Master TOC

Return to Section TOC
Return to Master TOC

Return to Section TOC
Return to Master TOC

INSTALLATION

Read this entire installation section before you start installation.

SAFETY PRECAUTIONS

WARNING

Do not attempt to use this equipment until you have thoroughly read all the operation and maintenance manuals supplied with your machine. They include important safety precautions; detailed engine starting, operating, and maintenance instructions; and parts lists.

ELECTRIC SHOCK can kill.



- Do not touch electrically live parts or electrodes with your skin or wet clothing.
- Insulate yourself from the work and ground.
- Always wear dry insulating gloves.



ENGINE EXHAUST can kill.

- Use in open, well ventilated areas or vent exhaust to the outside.
- Do not stack anything on or near the engine.



MOVING PARTS can injure.

- Do not operate this equipment with any of its doors open or guards off.
- Stop the engine before servicing it.
- Keep away from moving parts.

See additional safety information at the front of this manual.

Only qualified personnel should install, use, or service this equipment.

LOCATION AND VENTILATION

Always operate the Classic III and Classic IIID with the doors closed. Leaving the doors open changes the designed air flow and may cause overheating. Always operate the welder with the case roof on and all machine components completely assembled.

Whenever you use the welder, be sure that clean cooling air can flow through the machine's engine and the generator. Avoid dusty, dirty areas. Also, keep the machine away from heat sources. Do not place the back end of the generator anywhere near hot engine exhaust from another machine. And of course, make sure that engine exhaust is ventilated to an open, outside area.

The Classic III and Classic IIID may be used outdoors. Do not set the machine in water. Such practices pose safety hazards and cause improper operation and corrosion of parts.

STORING

1. Store the machine in a cool, dry place when it is not in use. Protect it from dust and dirt. Keep it where it can't be accidentally damaged from construction activities, moving vehicles, and other hazards.
2. Drain the engine oil and refill with fresh 10W30 oil. Run the engine for about five minutes to circulate oil to all the parts. See the **Maintenance** section of this manual for details on changing oil.
3. Remove the battery, recharge it, and adjust the electrolyte level. Store the battery in a dry, dark place. See the **Maintenance** section for information about charging the battery.
4. See your engine operation manual for further information on fuel and engine preservation.

Classic III and IIID



INSTALLATION

STACKING

Classic III and Classic IIID machines CANNOT be stacked.

TILTING

Place the machine on a secure, level surface whenever you use it or store it. Any surfaces you place it on other than the ground must be firm, non-skid, and structurally sound.

The engine is designed to run in a level position for best performance. If you do operate it at a slight angle, be sure to check the oil regularly and keep the oil level at the FULL mark as it would be in its normal level condition. Also, fuel capacity will be a little less at an angle.

LIFTING

The Classic III weighs 1406 lb./638 kg. The Classic IIID weighs 1445 lb./657 kg. A lift bail is provided for lifting with a hoist.

WARNING



FALLING EQUIPMENT can cause injury.

Do not lift this machine using the lift bail if it is equipped with a heavy accessory such as a trailer.

Lift only with equipment of adequate lifting capacity. Be sure the machine is stable when lifting.

HIGH ALTITUDE OPERATION

It may be necessary to derate welder output at higher altitudes. Some engine adjustment may be required. Contact a Continental Service Representative.

PRE-OPERATION ENGINE SERVICE

Read and understand the information about the engine in the **Operation** and **Maintenance** sections of this manual before you operate the Classic III or Classic IIID.

WARNING

Keep hands away from the engine muffler or HOT engine parts.

- Stop the engine when fueling.
- Do not smoke when fueling.
- Remove the fuel cap slowly to release pressure.
- Do not overfill the fuel tank.
- Wipe up spilled fuel and allow the fumes to clear before starting the engine.
- Keep sparks and flame away from the fuel tank.

OIL



The Classic III and Classic IIID are shipped with the engine filled with SAE 10W-30 oil. This should be fine for most ambient operating temperature conditions. See the engine operation manual for specific recommendations. **CHECK THE OIL LEVEL BEFORE YOU START THE ENGINE.** This is an added precaution. When full, the oil level should be up to but not over the FULL mark on the dipstick. If it is not full, add enough oil to fill it to the full mark. DO NOT overfill.

For more oil fill and service information, see the *Maintenance* section of this manual.



FUEL

Fill the fuel tank with the grade of fuel recommended in the engine operation manual. The Classic III and Classic IIID have a 15 gallon (57 liter) fuel tank with a top fill and fuel gauge mounted on the control panel. See the **Operation** and **Maintenance** sections of this manual for more details about fuel.



BATTERY CONNECTIONS

The Classic III and Classic IIID are shipped with the negative battery cable disconnected. Before you operate the machine, make sure the IGNITION switch is in the OFF position and attach the disconnected cable securely to the battery terminal. If the battery is discharged and won't start the engine, see the battery charging instructions in the **Maintenance** section.

Classic III and IIID



INSTALLATION

COOLING SYSTEM

The cooling system has been filled at the factory with a 50-50 mixture of ethylene glycol antifreeze and water. Check the radiator level and add a 50-50 solution as needed. (See your engine manual or antifreeze container for alternate antifreeze recommendations.)

MUFFLER

This welder is supplied with an adjustable rain cap for the muffler. Install the rain cap using the clamp provided with the outlet facing away from the direction in which this unit will be transported. This will minimize the amount of water and debris that could enter the muffler during transportation.

EXHAUST SPARK ARRESTER

Some federal, state or local laws may require that gasoline or diesel engines be equipped with exhaust spark arresters when they are operated in certain locations where unarrested sparks may present a fire hazard. The standard mufflers included with these welders do not qualify as a spark arrester. When required by local regulations, suitable spark arresters must be installed and properly maintained.

CAUTION

Use of an incorrect arrester may lead to engine damage or performance loss. Contact the engine manufacturer for specific recommendations.

TRAILER

If you use a non-Lincoln trailer, you must assume responsibility that the method of attachment and usage does not result in a safety hazard nor damage the welding equipment. Some of the factors to be considered are as follows:

1. Design capacity of the trailer vs. the weight of the Lincoln equipment and likely additional attachments.
2. Proper support of, and attachment to, the base of the welding equipment so there will be no undue stress to the framework.
3. Proper placement of the equipment on the trailer to ensure stability side to side and front to back. This includes when being moved and when standing by itself for operation or service.
4. Typical conditions of use, such as travel speed, roughness of the surfaces where the trailer will be used, environmental conditions, likely maintenance.
5. Conformance with federal, state, and local laws. Consult applicable federal, state, and local laws about specific requirements for use on public highways.

INSTALLATION

ELECTRICAL OUTPUT CONNECTIONS

See Figure A.1 for the location of the 115 and 230 volt receptacles, weld output terminals, and ground stud.

WELDING CABLE CONNECTIONS

CABLE INSTALLATION AND CABLE SIZES

With the engine off, connect the electrode and work cables to the terminals located on the fuel tank mounting rail. (See size recommendations below.) For positive polarity, connect the electrode cable to the terminal marked Positive (+). For Negative polarity, connect the electrode cable to the Negative (-) terminal. These connections should be checked periodically and tightened if necessary.

⚠ CAUTION

- Loose connections will cause the output terminals to overheat. The terminals may eventually melt.
- Do not cross the welding cables at the output terminal connection. Keep the cables isolated and separate from one another.

When welding at a considerable distance from the welder, be sure you use ample size welding cables. Table A.1 lists recommended cable sizes and lengths for rated current and duty cycle. Length refers to the distance from the welder to the work and back to the welder. Cable diameters are increased for long cable lengths to reduce voltage drops.

Lincoln Electric offers a welding accessory kit with the properly specified welding cables. See the **Accessories** section of this manual for more information.

FIGURE A.1 - CLASSIC III & CLASSIC IIID OUTPUT CONNECTIONS

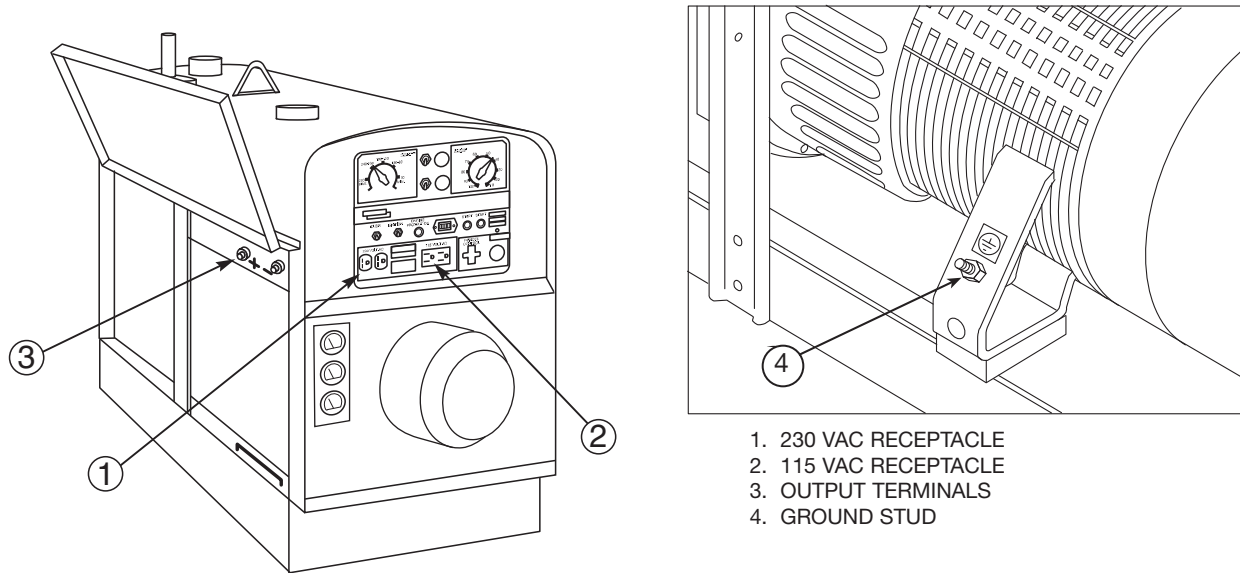

1. 230 VAC RECEPTACLE
2. 115 VAC RECEPTACLE
3. OUTPUT TERMINALS
4. GROUND STUD

**TABLE A.1 - RECOMMENDED COPPER WELDING CABLE SIZE AND LENGTH
TOTAL COMBINED LENGTH OF ELECTRODE AND WORK CABLES**

Amps	Duty Cycle	Cable sizes for combined length of electrode plus work cable	
		Up to 200 ft.	200 to 250 ft.
225	100%	1	1/0
300	50%	1/0	2/0
350	30%	2/0	3/0

Classic III and IIID



Return to Section TOC
Return to Master TOC

INSTALLATION

MACHINE GROUNDING

According to the United States National Electrical Code, the frame of this portable generator is not required to be grounded and is permitted to serve as the grounding means for cord connected equipment plugged into its receptacles.

Some state, local or other codes or unusual operating circumstances may require the machine frame to be grounded. It is recommended that you determine the extent to which such requirements may apply to your particular situation and follow them explicitly. A

 machine grounding stud marked with the symbol is provided on the welding generator frame foot. (If an older portable welder does not have a grounding stud, connect the ground wire to an unpainted frame screw. See Figure A.2.

In general, if the machine is to be grounded, it should be connected with a #8 or larger copper wire to a solid earth ground such as a metal water pipe going into the ground for at least ten feet and having no insulated joints, or to the metal framework of a building which has been effectively grounded. The U.S. National Electrical Code lists a number of alternate means of grounding electrical equipment.

WARNING

Do not ground the machine to a pipe that carries explosive or combustible material.

When the Classic III and Classic IIID are mounted on a truck or a trailer, the machine generator ground stud **MUST** be securely connected to the metal frame of the vehicle. See Figure A.2. The ground stud is marked with the ground symbol.

AUXILIARY POWER RECEPTACLES, PLUGS, AND HAND-HELD EQUIPMENT

The AC auxiliary power, supplied as a standard, has a rating of 3.0 kVA of 115/230V AC (60 hertz).

With the 3.0 kVA, 115/230V AC auxiliary power, one 115V duplex and one 230V duplex grounding type receptacle are provided. The circuit is protected with circuit breakers.

The rating of 3.0 kVA permits a maximum continuous current of 13 amps to be drawn from the 230 volt duplex receptacle. Or a total of 26 amps can be drawn from the 115 volt duplex receptacle. The 115 volt duplex receptacle has a configuration which permits 15 amps to be drawn from either half of the receptacle. **The total combined load of all receptacles is not to exceed 3.0 kVA.**

For further protection against electric shock, any electrical equipment connected to the generator receptacles must use a three-blade, grounded type plug or an Underwriter's Laboratories (UL) approved double insulation system with a two-blade plug. Lincoln offers an accessory plug kit that has the right type of plugs. See the **Accessories** section of this manual for details.

If you need ground fault protection for hand-held equipment, refer to the **Accessories** section of this manual for the GFCI Receptacle kit.

CIRCUIT BREAKERS



Classic III and Classic IIID welders are equipped with circuit breakers on the 115 and the 230 volt receptacles for overload protection. Under high heat a breaker may tend to trip at lower loads than it would normally.

Operation with high ambient temperatures may cause the breakers to trip at lower than normal loads.

CAUTION

Never bypass the circuit breakers. Without overload protection, the Classic III and Classic IIID could overheat and/or cause damage to the equipment being used.

FIGURE A.2 - GROUND STUD LOCATION

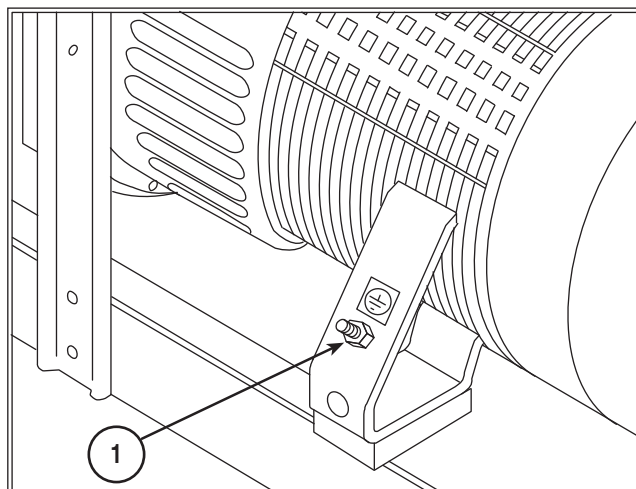

1. GROUND STUD

Classic III and IIID



Return to Section TOC
Return to Master TOC

Return to Section TOC
Return to Master TOC

Return to Section TOC
Return to Master TOC

Return to Section TOC
Return to Master TOC

Classic III and IIID



TABLE OF CONTENTS - OPERATION SECTION -

Operation	Section B
Safety Instructions	B-2
General Description	B-2
Recommended Applications	B-3
Welder	B-3
Generator	B-3
Operational Features and Controls	B-3
Design Features	B-3
Welding Capability	B-4
Limitations	B-4
Controls and Settings	B-5
Welder/Generator Controls	B-5
Control of Welding Current	B-6
Gasoline Engine Controls.....	B-7
Diesel Engine Controls	B-8
Engine Operation	B-9
Before Starting the Engine	B-9
Starting the Gasoline Engine.....	B-9
Starting the Diesel Engine.....	B-9
Stopping the Engine.....	B-10
Break-in Period	B-10
Welding Operation	B-11
DC Constant Current Stick or TIG Welding	B-11
DC Wire Feed Welding (Constant Voltage)	B-12
Auxiliary Power	B-13

Return to Master TOC

Return to Master TOC

Return to Master TOC

Return to Master TOC



OPERATION

OPERATING INSTRUCTIONS

Read and understand this entire section before operating your Classic III or Classic IIID.

SAFETY INSTRUCTIONS

WARNING

Do not attempt to use this equipment until you have thoroughly read all the operation and maintenance manuals supplied with your machine. They include important safety precautions; detailed engine starting, operating, and maintenance instructions; and parts lists.

ELECTRIC SHOCK can kill.



- Do not touch electrically live parts or electrodes with your skin or wet clothing.
- Insulate yourself from the work and ground.
- Always wear dry insulating gloves.

FUMES AND GASES can be dangerous.



- Keep your head out of fumes.
- Use ventilation or exhaust to remove fumes from breathing zone.

WELDING SPARKS can cause fire or explosion.



- Keep flammable material away.
- Do not weld on containers that have held combustibles.

ARC RAYS can burn.



- Wear eye, ear, and body protection.

WARNING



ENGINE EXHAUST can kill.

- Use in open, well ventilated areas or vent exhaust to the outside.
- Do not stack anything on or near the engine.



MOVING PARTS can injure.

- Do not operate this equipment with any of its doors open or guards off.
- Stop the engine before servicing it.
- Keep away from moving parts.

Only qualified personnel should install, use, or service this equipment.

GENERAL DESCRIPTION

The Classic III and Classic IIID are heavy duty engine driven DC arc welding power sources capable of providing constant current output for stick welding or DC TIG welding. These welders are wound with all copper coils and feature improved door latches and stainless steel hinges. With the addition of the optional K623-1 Wire Feed Module, the welders will provide constant voltage output for running the LN-7, LN-23P, or LN-25 wire feeders.

The Classic III and Classic IIID have a current range of 40-350 DC amps with a 50% duty cycle at 300 amps/32 volts. The units are also capable of providing 3.0 kVA of 115/230 volt, 60 Hertz AC auxiliary power.

The Classic III uses the Continental TM27 four-cylinder, industrial water-cooled gasoline engine, and the Classic IIID uses the Continental TMD27 industrial water cooled diesel engine.

Classic III and IIID



OPERATION

RECOMMENDED APPLICATIONS

WELDER

The Classic III and Classic IIID provide excellent constant current DC welding output for stick (SMAW) welding and for DC TIG welding. When equipped with the wire feed module, they also offer constant voltage output for DC semiautomatic wire feed welding. For more details on using the machine as a welder, see **Welding Operation** in the **Operation** section of this manual.

GENERATOR

The Classic III and Classic IIID are also capable of providing 3.0 kVA of 115/230 volts of 60 Hertz AC auxiliary power.

OPERATIONAL FEATURES AND CONTROLS

The Classic III and Classic IIID are designed for simplicity. Therefore, it has very few operating controls. Two controls are used for welding operations:

- A five-position CURRENT RANGE SELECTOR switch selects current output ranges for constant current stick or TIG applications and constant voltage wire feed applications (with optional Wire Feed Module - see the **Accessories** section)
- A FINE CURRENT ADJUSTMENT control for fine adjustment of current from minimum to maximum within each range

Controls for the engine include a two-position IGNITION ON/OFF toggle switch, a START push-button, and a two-position IDLER switch that selects engine speed for welding or auxiliary power applications. See **Engine Operation** in the **Operation** section of this manual for details about starting, running, stopping, and breaking in the engine.

DESIGN FEATURES

- All copper windings for long life and dependable operation.
- Constant current DC Stick welding (SMAW) process capability with output range from 40 - 350 DC amps.
- Constant current DC TIG Welding with output across the entire range of settings.
- Work and Electrode welding cable mounting terminals.
- Separate ground stud for safe connection of case to earth ground.
- Duplex, 230 volt auxiliary power receptacle.
- Duplex, 115 volt auxiliary power receptacle.
- Integrated generator output overload protection through four 15 amp circuit breakers.
- Electric starting.
- Battery Charging Ammeter.
- Engine Oil Pressure Gauge. (Classic III D only)
- Engine Hour Meter for determining periodic maintenance.
- Top-of-the-line 38.9 HP Continental gasoline (Classic III) or 45 HP Continental diesel engine (Classic IIID).
- Top-mounted 15 gallon (57.0 liter) fuel tank with convenient top fill.
- Automatic engine shutdown protection for low oil pressure or high engine coolant temperature (Classic IIID).
- Automatic engine idler goes to low idle approximately 15 seconds after welding for greater fuel economy; includes high idle switch.

OPERATION

WELDING CAPABILITY

The Classic III and Classic IIID are rated 300 amps, 32 volts constant current DC at 50% duty cycle based on a ten minute time period. Longer duty cycles at lower output currents are possible.

The current is continuously variable from 40 to 350 amps DC.

LIMITATIONS

The Classic III and Classic IIID are not recommended for any processes besides those that are normally performed using DC stick welding (SMAW) and DC TIG welding. Specific limitations on using the Classic III and Classic IIID for these processes are described in the **Welding Operation** section of this manual. Constant voltage welding is available with the optional Wire Feed Module.

Return to Section TOC

Return to Section TOC

Return to Section TOC

Return to Section TOC

Return to Master TOC

Return to Master TOC

Return to Master TOC

Return to Master TOC

Classic III and IIID



OPERATION

CONTROLS AND SETTINGS

The welder/generator controls are located on the Output Control Panel of the machine case front. Engine idler control and start/stop controls are also on

the case front. Welding output terminals and ground stud are located on the machine left side, under the door. See Figures B.1, B.2 and B.3 and the explanations that follow.

FIGURE B.1 – OUTPUT CONTROLS

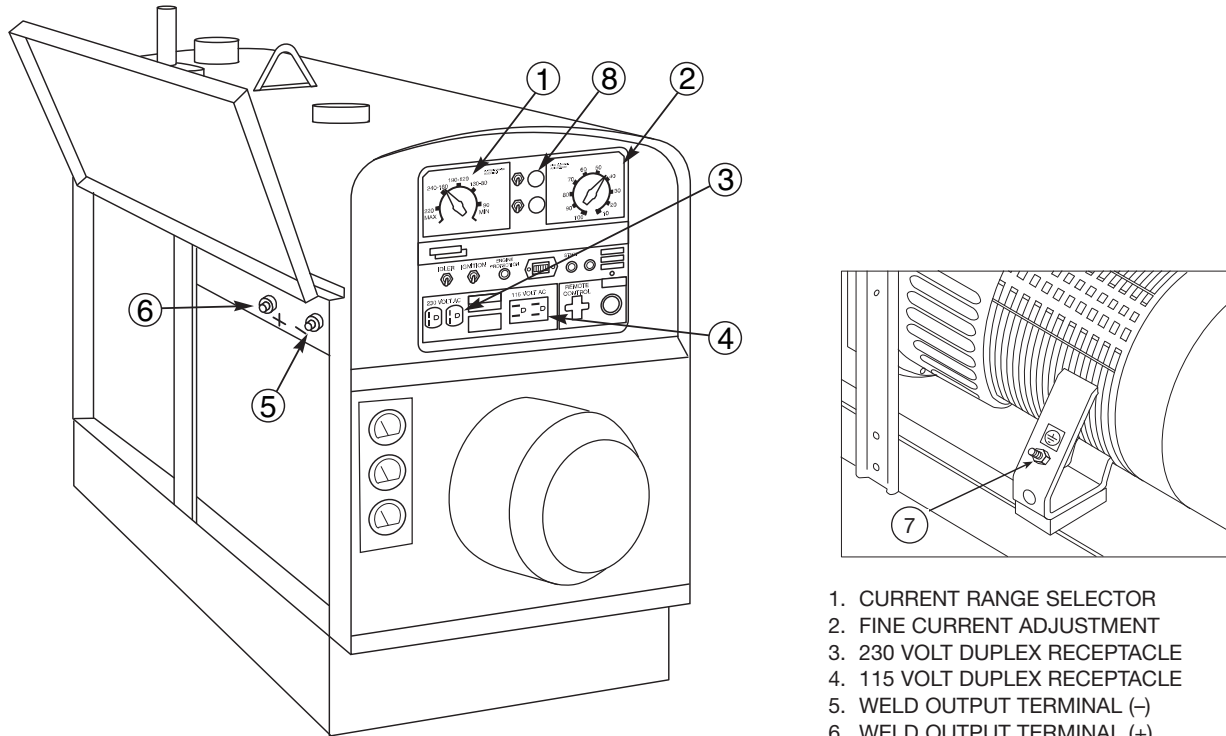

1. CURRENT RANGE SELECTOR
2. FINE CURRENT ADJUSTMENT
3. 230 VOLT DUPLEX RECEPTACLE
4. 115 VOLT DUPLEX RECEPTACLE
5. WELD OUTPUT TERMINAL (-)
6. WELD OUTPUT TERMINAL (+)
7. GROUND STUD
8. OPTIONAL WIRE FEED MODULE CONTROLS

WELDER/GENERATOR CONTROLS

See Figure B.1 for the location of the following features:

1. **CURRENT RANGE SELECTOR:** Selects ranges of continuous current output for constant current stick or TIG applications and constant voltage wire feed applications (with optional Wire Feed Module). See *Control of Welding Current* for more information.
2. **FINE CURRENT ADJUSTMENT:** Allows fine adjustment of current within the selected output range. See *Control of Welding Current* for more information.
3. **230 VOLT DUPLEX RECEPTACLE:** Connection point for supplying 230 volt power to operate one or two electrical devices.
4. **115 VOLT DUPLEX RECEPTACLE:** Connection point for supplying 115 volt power to operate one or two electrical devices.
5. **WELD OUTPUT TERMINAL (-) WITH FLANGE NUT:** Provides the connection point for either the electrode holder or the work cable.
6. **WELD OUTPUT TERMINAL (+) WITH FLANGE NUT:** Provides the connection point for either the electrode holder or the work cable.
7. **GROUND STUD:** Provides a connection point for connecting the machine case to earth ground for the safest grounding procedure.

Classic III and IIID



OPERATION

CONTROL OF WELDING CURRENT

CAUTION

- DO NOT turn the CURRENT RANGE SELECTOR while welding because the current may arc between the contacts and damage the switch.
- DO NOT attempt to set the CURRENT RANGE SELECTOR between the five points designated on the nameplate.

See Figure B.2. The CURRENT RANGE SELECTOR provides five overlapping current ranges. The FINE CURRENT ADJUSTMENT adjusts the current from minimum to maximum within each range. Open circuit voltage is also controlled by the FINE CURRENT ADJUSTMENT, permitting control of the arc characteristics.

A high open circuit voltage setting provides the soft "buttering" arc with best resistance to pop-outs preferred for most welding. To get this characteristic, set the CURRENT RANGE SELECTOR to the lowest setting that still provides the current you need and set the FINE CURRENT ADJUSTMENT near maximum. For example: to obtain 175 amps and a soft arc, set the CURRENT RANGE SELECTOR to the 190 -120 position and then adjust the FINE CURRENT ADJUSTMENT for 175 amps.

When a forceful "digging" arc is required, usually for vertical and overhead welding, use a higher CURRENT RANGE SELECTOR setting and lower open circuit voltage. For example: to obtain 175 amps and a forceful arc, set the CURRENT RANGE SELECTOR to 240-160 position and the FINE CURRENT ADJUSTMENT setting to get 175 amps.

Some arc instability may be experienced with EXX10 electrodes when trying to operate with long arc techniques at settings at the lower end of the open circuit voltage range.

FIGURE B.2 – CURRENT CONTROLS

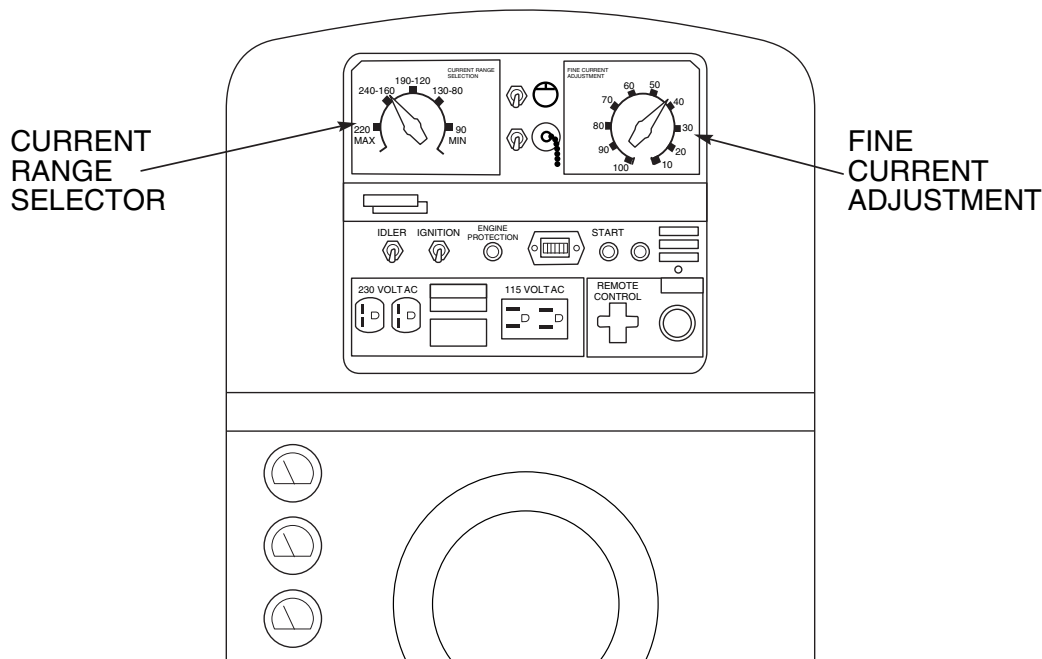

Classic III and IIID

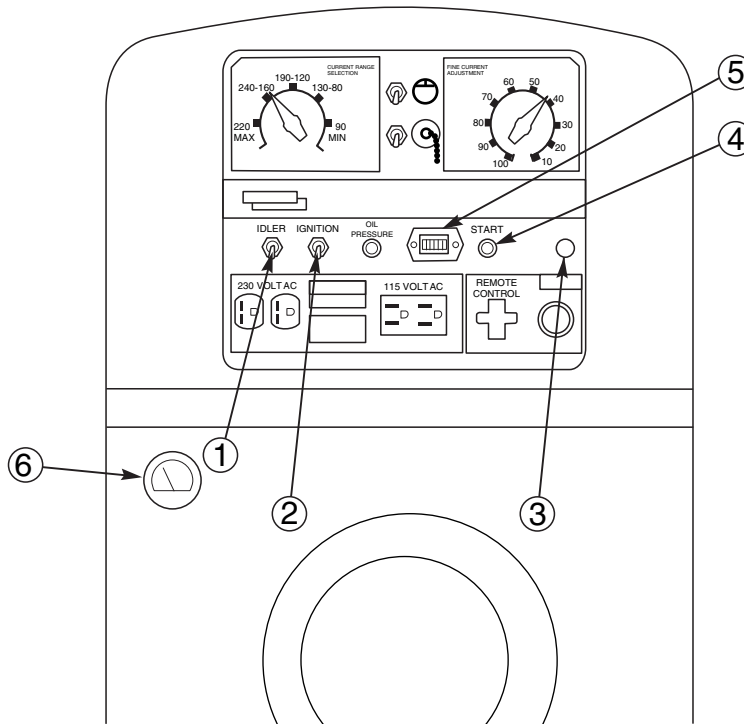

OPERATION

FIGURE B.3 – GASOLINE ENGINE CONTROLS

1. IDLER CONTROL TOGGLE SWITCH
2. IGNITION TOGGLE SWITCH
3. CHOKE
4. START PUSHBUTTON
5. ENGINE HOUR METER
6. AMMETER

GASOLINE ENGINE CONTROLS (CLASSIC III)

See Figure B.3 for the location of the following features:

1. **IDLER CONTROL TOGGLE SWITCH:** Adjusts the running speed of the engine. The switch has two positions, "HIGH" and "AUTO." In "HIGH," the engine runs continuously at high idle. In "AUTO," the idler control works as follows:

Welding: The engine accelerates to high speed when the electrode touches the work and strikes a welding arc. The engine returns to low idle approximately 15 seconds after welding stops, as long as no auxiliary power is being drawn.

Auxiliary Power: The engine accelerates to high speed when power is drawn at the receptacles for lights or tools. The engine returns to low idle approximately 15 seconds after demand for auxiliary power stops.

2. **IGNITION CONTROL TOGGLE SWITCH:** Has two positions, ON and OFF. When the switch is in the ON position, the engine can be started by pressing the START pushbutton. When the switch is placed in the OFF position, the engine stops.
3. **CHOKE:** Provides a richer air/fuel mixture for cold engine starting conditions. See the topic *Engine Operation* for details on setting the choke.

4. **START PUSHBUTTON:** Press the START button to start the engine. The IGNITION switch must be in the ON position.

NOTE: If you press the START pushbutton when the engine is running, you may damage the engine flywheel gear or starter motor.

5. **ENGINE HOUR METER:** Records engine running time. Use the meter to determine when to perform required maintenance.
6. **AMMETER:** Shows whether the charging circuit is performing its job of charging the battery when the engine is running. The meter will register discharge during starting, but then the needle should return to a position slightly toward positive during running. The needle will hold position in the center when the engine stops.

Classic III and IIID



OPERATION

FIGURE B.4 – DIESEL ENGINE CONTROLS

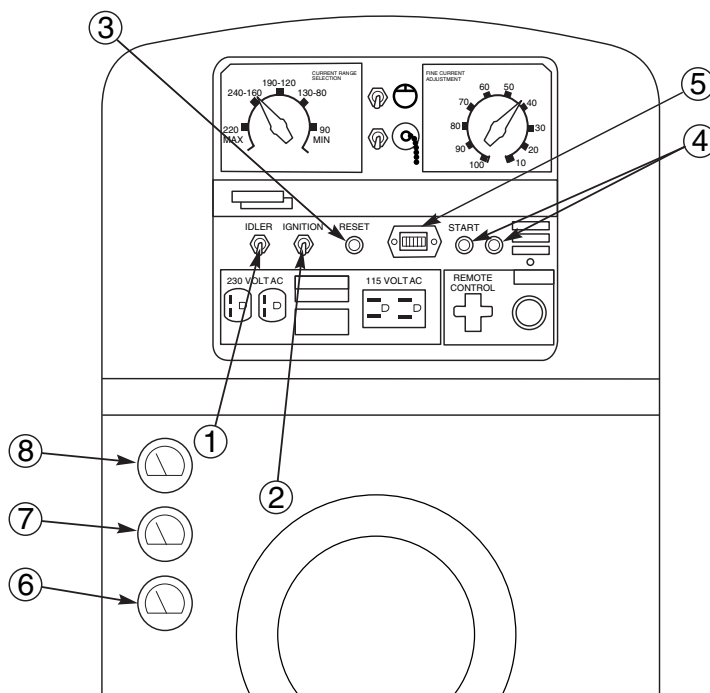

1. IDLER CONTROL TOGGLE SWITCH
2. IGNITION TOGGLE SWITCH
3. RESET BUTTON
4. START PUSHBUTTONS
5. ENGINE HOUR METER
6. OIL PRESSURE GAUGE
7. AMMETER
8. TEMPERATURE GAUGE

DIESEL ENGINE CONTROLS (CLASSIC IIID)

See Figure B.4 for the location of the following features:

1. **IDLER CONTROL TOGGLE SWITCH:** Adjusts the running speed of the engine. The switch has two positions, "HIGH" and "AUTO." In "HIGH," the engine runs continuously at high idle. In "AUTO," the idler control works as follows:

Welding: The engine accelerates to high speed when the electrode touches the work and strikes a welding arc. The engine returns to low idle approximately 15 seconds after welding stops, as long as no auxiliary power is being drawn.

Auxiliary Power: The engine accelerates to high speed when power is drawn at the receptacles for lights or tools. The engine returns to low idle approximately 15 seconds after demand for auxiliary power stops.

2. **IGNITION CONTROL TOGGLE SWITCH:** Has two positions, ON and OFF. When the switch is in the ON position, the diesel engine can be started by pressing the START pushbutton. When the switch is placed in the OFF position, the engine stops.
3. **RESET BUTTON:** Resets engine protection circuit. Press this button before starting the diesel engine.

4. **START AND GLOW PLUG PUSHBUTTONS:** Press the START button to start the diesel engine. The IGNITION switch must be in the ON position.

NOTE: If you press the START pushbutton when the engine is running, you may damage the engine flywheel gear or starter motor.

5. **ENGINE HOUR METER:** Records engine running time. Use the meter to determine when to perform required maintenance.
6. **OIL PRESSURE GAUGE:** Indicates engine oil pressure. If no oil pressure shows on the gauge within 30 seconds after startup, the engine should be stopped by placing the IGNITION switch in the OFF position.
7. **AMMETER:** Shows whether the charging circuit is performing its job of charging the battery when the engine is running. The meter will register discharge during starting, but then the needle should return to a position slightly toward positive during running. The needle will hold position in the center when the engine stops.
8. **TEMPERATURE GAUGE:** Indicates temperature of engine coolant.

Classic III and IIID



OPERATION

ENGINE OPERATION

WARNING

DO NOT RUN THE ENGINE AT EXCESSIVE SPEEDS. The maximum allowable high idle speed for the Classic III and Classic IIID is 1800 RPM, no load. Do NOT increase the idle speed on the engine. Severe personal injury and damage to the machine can result if it is operated at speeds above the maximum rated speed.

Read and understand all safety instructions included in the Continental engine instruction manual that is shipped with your welder.

BEFORE STARTING THE ENGINE

Check and fill the engine oil level:

1. Be sure the machine is on a level surface. 
2. Remove the engine oil dipstick and wipe it with a clean cloth. Reinsert the dipstick and check the level on the dipstick. See **Figure D.1** in the Maintenance section of this manual.
3. Add oil (if necessary) to bring the level up to the full mark. Do not overfill.
4. Replace the dipstick.

Check and fill the engine fuel tank:

WARNING

Do not add fuel near an open flame, welding arc or when the engine is running. Stop the engine and allow it to cool before refueling to prevent spilled fuel from vaporizing on contact with hot engine parts and igniting. Do not spill fuel when filling tank. If fuel is spilled, wipe it up and do not start engine until fumes have been eliminated. 

1. Remove the fuel tank cap.
2. Fill the tank to allow approximately 1/4 inch (5 mm) of tank space for fuel expansion. **DO NOT FILL THE TANK TO THE POINT OF OVERFLOW.**
3. Replace the fuel tank cap and tighten securely.

NOTE: Purchase fuel in quantities that will be used within 30 days, to assure freshness.

STARTING THE CLASSIC III CONTINENTAL TM27 GASOLINE ENGINE

NOTE: Remove all loads connected to the AC power receptacles before starting the engine.

1. Turn the IDLER switch to "HIGH".
2. Turn the IGNITION switch to ON.
3. Pull out the CHOKE control.
4. Press the START button.
5. If the engine fails to start in 60 seconds, wait 30 seconds before repeating the above procedure.
6. Allow engine to run at high idle speed for several minutes to warm the engine. Cold engines tend to run at a speed too slow to supply the voltage required for proper automatic idler operation.
7. As engine warms, slowly return the CHOKE control to the OFF position.

STARTING THE CLASSIC IIID CONTINENTAL TMD27 ENGINE

NOTE: Remove all loads connected to the AC power receptacles before starting the engine.

1. Place the IDLER switch in the "HIGH" position and the IGNITION switch in the ON position. Press the RESET button.
2. Press the GLOW PLUG button for 10 to 20 seconds.
3. While holding down the GLOW PLUG button, press the START button. Release both buttons when the engine starts.

NOTE: If the engine fails to start in 60 seconds, the RESET button will pop out. Wait 30 seconds then repeat step 1, 2, and 3.

4. When the engine starts running, observe the oil pressure. If no pressure shows within 30 seconds, stop the engine and consult the engine operating manual.
5. Allow the engine to run at high idle for several minutes to warm the engine prior to welding. Extreme cold weather may require longer glow plug operation.

WARNING

Under NO conditions should ether or other starting fluids be used in conjunction with the glow plugs. This may cause an explosion or fire!

Classic III and IIID



OPERATION

STOPPING THE ENGINE (GASOLINE OR DIESEL)

1. Place the IGNITION switch in the OFF position.

At the end of each day's welding, drain accumulated dirt and water from the sediment bowl under the fuel tank and from the fuel filter (diesel engine, Classic IIID) per instructions in the engine manufacturer's operating manual. Refill the fuel tank to minimize moisture condensation in the tank. Also, running out of fuel tends to draw dirt into the fuel system. Check the crankcase oil level.

When hauling the welder between job sites, close the fuel feed valve beneath the tank. In gasoline engines, failing to turn off the fuel when traveling can cause carburetor flooding and difficult starting at the new job site.

In diesel engines, if the fuel supply is cut off or runs out while the fuel pump is operating, air may be entrapped in the fuel distribution system. See "How to Eliminate Air From the Fuel System" in the **Maintenance** section.

BREAK-IN PERIOD

When an engine is started for the first time, some of the oil will be needed to fill the passages of the lubricating system. Therefore, on initial starting, run the engine for about five minutes and then stop the engine and recheck the oil. If the level is down, fill to the full mark again.

The engine controls were properly set at the factory and should require no adjusting when received.

Any engine will use a small amount of oil during its break-in period. For the gasoline or diesel engine on the Classic III or Classic IIID, break-in is about 200 running hours.

Check the oil twice a day during break-in. Change the oil and oil filter cartridge after the first 25 hours of operation. Also change the fuel filter cartridge on the diesel engine. For more details, see the **Maintenance** section of this manual.

CAUTION

During break-in, subject the Classic III or Classic IIID to only moderate loads. Avoid long periods running at idle. Before stopping the engine, remove all loads and allow the engine to cool several minutes.

Classic III and IIID



Return to Section TOC

Return to Section TOC

Return to Section TOC

Return to Section TOC

Return to Master TOC

Return to Master TOC

Return to Master TOC

Return to Master TOC

OPERATION

WELDING OPERATION

TO USE THE CLASSIC III OR CLASSIC IIID FOR DC CONSTANT CURRENT STICK OR TIG WELDING:

1. Remove the flange nuts from the weld output terminals and place the work and electrode welding cables over the terminals. See Figure B.5. Replace and tighten the flange nuts securely. Be sure the connections are tight.
2. Select the appropriate electrode.
3. Attach the work clamp securely to the work you are welding.
4. Insert the electrode into the electrode holder.
5. Start the engine. See **Engine Operation** in this section of the manual.
6. Set the Idler Switch to "AUTO."
7. Set the CURRENT RANGE SELECTOR to a setting equal to or slightly higher than the desired welding current.
8. Set the FINE CURRENT ADJUSTMENT to the setting that gives the best arc characteristics for the range selected. See **Control of Welding Current** in this section of the manual.
9. Strike an arc and begin welding.

After you finish welding:

1. Stop the engine. See **Engine Operation** in this section of the manual.
2. Allow the electrode and work to cool completely.
3. Remove the work clamp from the work.
4. Remove any remaining piece of electrode from the electrode holder.

FIGURE B.5 – WELDING CIRCUIT CONNECTIONS FOR STICK WELDING

1. FLANGE NUT
2. ELECTRODE CABLE
3. ELECTRODE HOLDER
4. ELECTRODE
5. WORK
6. WORK CLAMP
7. WORK CABLE

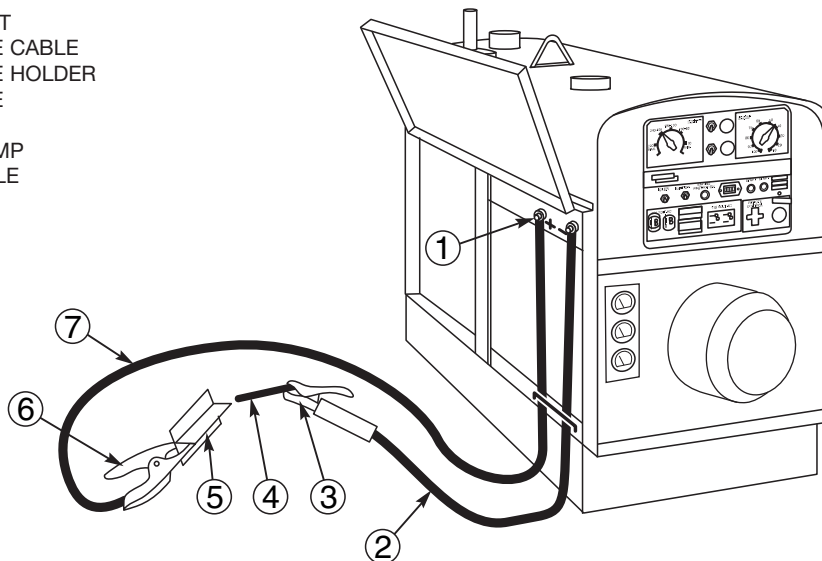

Classic III and IIID



OPERATION

TO USE THE CLASSIC III OR CLASSIC IIID FOR DC WIRE FEED WELDING (CONSTANT VOLTAGE WITH WIRE FEED MODULE):

1. Connect the LN-25, LN-23P, or LN-7 Wire Feeder. Follow the installation instructions provided with the wire feeder.
2. Set the machine for CV operation.
3. Start the engine. See **Engine Operation** in this section of the manual.
4. Set the Idler Switch to "AUTO."
5. Set the CURRENT RANGE SELECTOR to a setting appropriate for your wire size and wire feed speed. See Table B.1 for recommended settings.
6. Set the VOLTAGE ADJUSTMENT to the setting that gives the best arc characteristics for the range selected.
7. Pull the gun trigger and begin welding.

TABLE B.1
RANGE SETTINGS FOR WIRE SIZE/SPEED

Diameter (inches)	Wire Speed Range (inches/minute)	Appropriate Current Range
.035	80-110	80 to 130 Amps
.045	70-130	120 to 190 Amps
.068	40-90	150 to 240 Amps

Classic III and IIID



Return to Section TOC
Return to Master TOC

Return to Section TOC
Return to Master TOC

Return to Section TOC
Return to Master TOC

Return to Section TOC
Return to Master TOC

AUXILIARY POWER

WARNING

Be sure that any electrical equipment plugged into the generator AC power receptacles can withstand a $\pm 10\%$ voltage and a $\pm 3\%$ frequency variation.

The AC auxiliary power, supplied as a standard, has a rating of 3.0 kVA of 115/230V AC power (60 hertz).

One 115V duplex and one 230V duplex grounding type receptacle are provided. The circuit is protected with circuit breakers.

The rating of 3.0 kVA permits a maximum continuous current of 13 amps to be drawn from the 230 volt duplex receptacle. Or a total of 26 amps can be drawn from the 115 volt duplex receptacle. The 115 volt duplex receptacle permits 15 amps to be drawn from either half. The total combined load of all receptacles must not exceed 3.0 kVA.

An optional power plug kit is available. When this kit is specified, the customer is supplied with a plug for each receptacle. See the **Accessories** section of this manual.

An optional GFCI 115 volt receptacle kit is also available. Note that the use of this GFCI kit reduces available current to a total of 20 Amps of available 115 volt power. See the **Accessories** section of this manual.

To use the generator as an auxiliary power supply:

1. Start the diesel engine. See **Engine Operation** in this section of the manual.
2. Set the IDLER switch to AUTO. Set the CURRENT RANGE SELECTOR to "MAX." See **Figure B.1**.
3. Plug the load(s) into the appropriate 115 volt or 230 volt power receptacle.

Return to Section TOC
Return to Master TOC
Return to Section TOC
Return to Master TOC
Return to Section TOC
Return to Master TOC
Return to Section TOC
Return to Master TOC

Classic III and IIID



TABLE OF CONTENTS - ACCESSORIES -

Accessories.....	Section C
Options/Accessories.....	C-2
TIG Welding Accessories.....	C-3
Semiautomatic FCAW and MIG Welding Accessories.....	C-3
Connection of Lincoln Electric Wire Feeders	C-4
Connection of the LN-7 using K867 Universal Adapter	C-4
Connection of the LN-7 using K584 Input Cable Assembly.....	C-5
Connection of the LN-25 using K867 Universal Adapter	C-6
Connection of the LN-25 "Across the Arc".....	C-7
Connection of the LN-23P using the K1350-1 Adapter Kit	C-8
Connection of the K488 SG Control Module and K487 Magnum Spool Gun	C-9

Return to Master TOC

Return to Master TOC

Return to Master TOC

Return to Master TOC

Classic III and IIID



ACCESSORIES

OPTIONS/ACCESSORIES

The following options/accessories are available for your Classic III or Classic IIID from your local Lincoln Distributor.

Trailer (K913) - Two-wheeled trailer for in-plant and yard towing. Various hitches and accessories are available. For highway use, consult applicable federal, state, and local laws.

Trailer (K780) - Two-wheeled trailer with brakes, lights, and fenders. (For highway use, consult applicable state and local laws.)

Power Plug Kit (K802-C) - Provides a plug for each auxiliary receptacle.

Linc Thaw™ Control Unit (L2964-5) - Includes meter and fuses to protect the welder when thawing frozen water pipes.

WARNING

PIPE THAWING is not a CSA approved procedure. If not done properly, it can result in fire, explosion, damage to pipes, wiring, and the welder as well as other unsafe or hazardous conditions. Do not use a welder to thaw pipes before reviewing Lincoln Bulletin E695.1 (dated October 1987 or later).

Wire Feed Module - (K623-1) - Provides constant voltage output for semiautomatic welding. Includes remote for CV mode and internal "Cold Tip Contactor."

Accessory Kit (K703) - Includes the following:

- Electrode cable
- Work cable
- Headshield
- Work clamp
- Insulated electrode holder

Remote Control - (K924-1) - Includes a receptacle switch and control box with 100 ft. (7.5 meters) of 4-conductor cable. Allows fine current and OCV to be controlled remotely.

GFCI Receptacle Kit (K896-2) - Includes a UL approved 115 volt ground fault circuit interrupter receptacle (duplex type) with covers and installation instructions. Each half of the receptacle is rated 15 amps, but the maximum total current from the GFCI duplex is limited to 20 amps. The GFCI receptacle replaces the factory installed 115 volt duplex receptacle.

Classic III and IIID



ACCESSORIES

TIG WELDING ACCESSORIES

K930-2 TIG Module - The TIG Module is an accessory that provides high frequency & shielding gas control for DC GTAW (TIG) welding applications.

The TIG Module is supplied without accessories. Arc start switches, amptrols, cables, torches and mounting brackets must be purchased separately.

SEMIAUTOMATIC WELDING ACCESSORIES

LN-25 Wire Feeder - This portable wire feeder is capable of CC/CV wire feed welding.

LN-7 Wire Feeder - Semiautomatic, constant speed wire feeder. For CV operation only.

LN-23P Wire Feeder - Portable CV unit for Innershield pipe welding. Control cable operates contactor inside wire feed module for "cold" electrode. Requires K350 and K867 adapter cables.

NOTE: Gas-shielded welding requires a Magnum Gun. Gasless welding requires an Innershield Gun.

Magnum Spool Gun (K487-25) - A lightweight, semi-automatic wire feeder for aluminum welding with argon gas. Has built-in remote wire speed control in the handle. Requires the K488 SG Control Module with appropriate control cable. Includes 25 feet (7.6 meters) of power cable.

Return to Section TOC
Return to Master TOC
Return to Section TOC
Return to Master TOC
Return to Section TOC
Return to Master TOC
Return to Section TOC
Return to Master TOC

Classic III and IIID



ACCESSORIES

CONNECTION OF LINCOLN ELECTRIC WIRE FEEDERS

CONNECTION OF THE LN-7 TO THE CLASSIC III OR CLASSIC IIID (EQUIPPED WITH K623-1 WIRE FEED MODULE) USING K867 UNIVERSAL ADAPTER (SEE FIGURE C.1.)

1. Shut the welder off.
2. Connect the electrode cable from the LN-7 to the “+” terminal of the welder. Connect the work cable to the “CV-” terminal of the welder.

NOTE: Welding cable must be sized for current and duty cycle of application.

NOTE: Figure C.1 shows the electrode connected for positive polarity. To change polarity, shut the welder off and reverse the electrode and work cables at the Classic III or Classic IIID output terminals.

3. Connect the K867 Universal Adapter to the K291 or K404 input cable and the 14 pin amphenol of the Classic III or Classic IIID as indicated in Figure C.1. Make the proper connections for local or remote control according to Figure C.1.

4. Connect the K291 or K404 input cable to the LN-7.
5. Place the IDLER switch in the “HIGH” position.

CAUTION

Any increase of the high idle engine RPM by changing the governor setting or overriding the throttle linkage will cause an increase in the AC auxiliary voltage. If this voltage goes over 140 volts, wire feeder control circuits may be damaged. The engine governor setting is preset at the factory — do not adjust above RPM specifications listed in this manual.

6. Adjust wire feed speed at the LN-7.

NOTE: For remote control, a K775 remote control is required. See Figure C.1.

CAUTION

When the welder is in local control, the electrode is always “HOT.”

FIGURE C.1
CLASSIC III OR CLASSIC IIID/LN-7 WITH K867 ADAPTER CONNECTION DIAGRAM

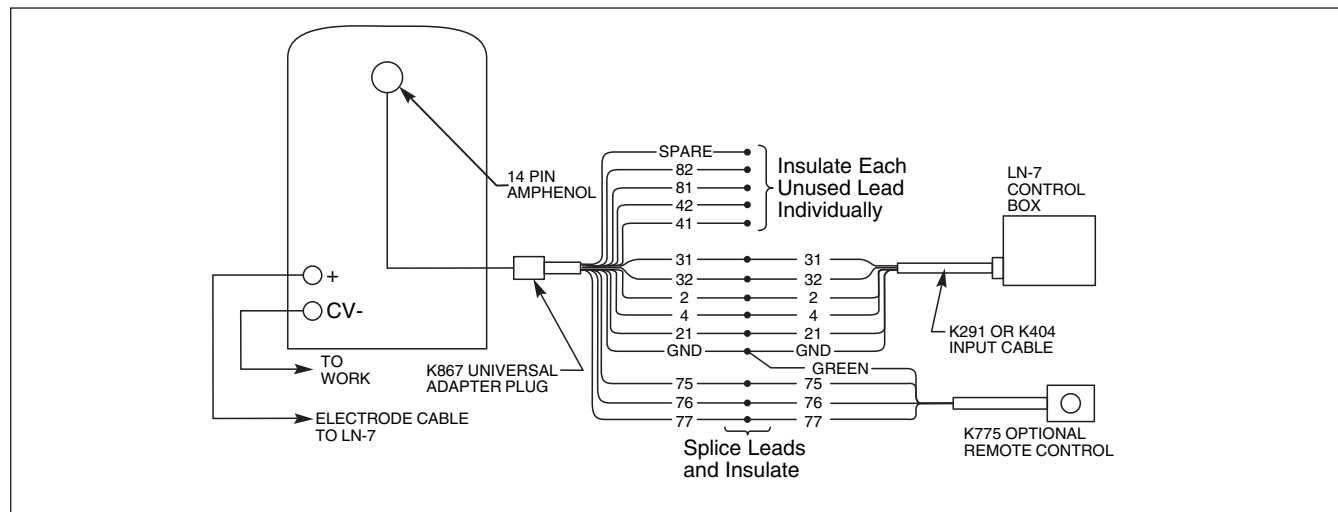

Classic III and IIID



ACCESSORIES

CONNECTION OF THE LN-7 TO THE CLASSIC III OR CLASSIC IIID (EQUIPPED WITH K623-1 WIRE FEED MODULE) USING K584 INPUT CABLE ASSEMBLY (SEE FIGURE C.2.)

1. Shut the welder off.
2. Connect the electrode cable from the LN-7 to the "+" terminal of the welder. Connect the work cable to the "CV-" terminal of the welder.

NOTE: Welding cable must be sized for current and duty cycle of application.

NOTE: Figure C.2 shows the electrode connected for positive polarity. To change polarity, shut the welder off and reverse the electrode and work cables at the Classic III or Classic IIID output terminals.

3. Connect the input cable from the K584-XX Input Cable Assembly to the 14 pin amphenol on the K864 adapter and the input cable plug on the LN-7.
4. Connect the K864 adapter to the 14 pin amphenol on the Classic III or Classic IIID.
5. Place the IDLER switch in the "HIGH" position.

CAUTION

Any increase of the high idle engine RPM by changing the governor setting or overriding the throttle linkage will cause an increase in the AC auxiliary voltage. If this voltage goes over 140 volts, wire feeder control circuits may be damaged. The engine governor setting is preset at the factory — do not adjust above RPM specifications listed in this manual.

6. Adjust wire feed speed at the LN-7.

NOTE: For remote control, a K857 control is required. Connect it to the K864 adapter.

CAUTION

When the welder is in local control, the electrode is always "HOT."

FIGURE C.2
CLASSIC III OR CLASSIC IIID/LN-7 WITH K584 INPUT CABLE ASSEMBLY CONNECTION DIAGRAM

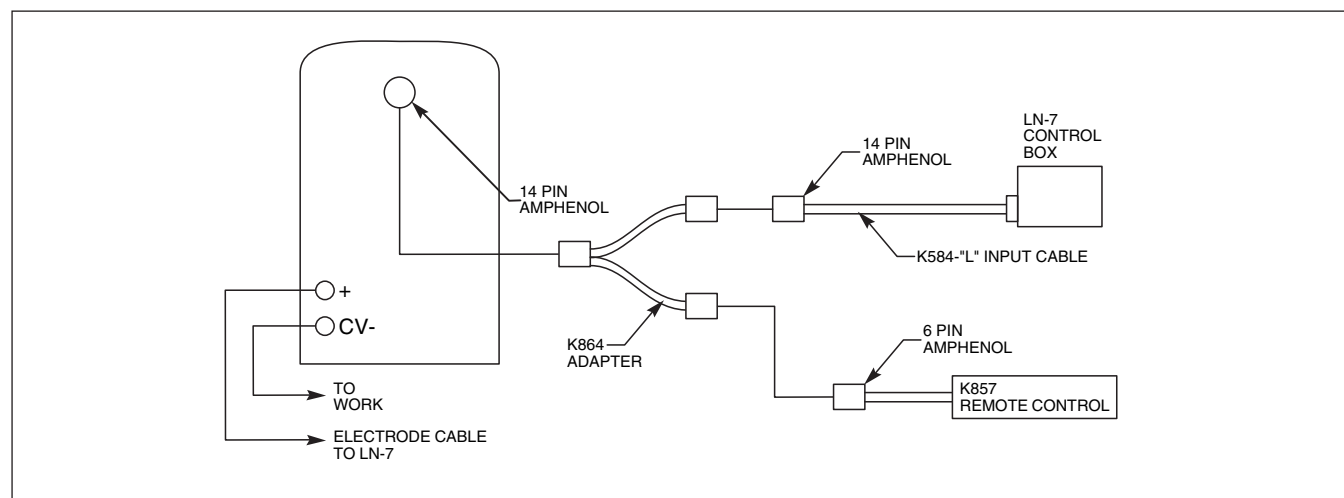

Classic III and IIID



ACCESSORIES

CONNECTION OF THE LN-25 TO THE CLASSIC III OR CLASSIC IIID (EQUIPPED WITH K623-1 WIRE FEED MODULE) USING K867 UNIVERSAL ADAPTER (SEE FIGURE C.3.)

1. Shut the welder off.
2. Connect the electrode cable from the LN-25 to the "+" terminal of the welder. Connect the work cable to the "CV-" terminal of the welder.

NOTE: Welding cable must be sized for current and duty cycle of application.

NOTE: Figure C.3 shows the electrode connected for positive polarity. To change polarity, shut the welder off and reverse the electrode and work cables at the Classic III or Classic IIID output terminals. Reverse the LN-25 polarity switch.

3. Connect the K867 Universal adapter to the K433 cable and the 14 pin amphenol of the Classic III or Classic IIID as indicated in Figure C.3. Mount the K433 to the welder according to instructions included with the K433 kit.

4. Connect the K432-L cable to the LN-25 equipped with the K431-1 remote output control kit.
5. Place the IDLER switch in the "HIGH" position.

CAUTION

Any increase of the high idle engine RPM by changing the governor setting or overriding the throttle linkage will cause an increase in the AC auxiliary voltage. If this voltage goes over 140 volts, wire feeder control circuits may be damaged. The engine governor setting is preset at the factory — do not adjust above RPM specifications listed in this manual.

6. Adjust wire feed speed and voltage at the LN-25.

FIGURE C.3
CLASSIC III OR CLASSIC IIID/LN-25 CONNECTION DIAGRAM

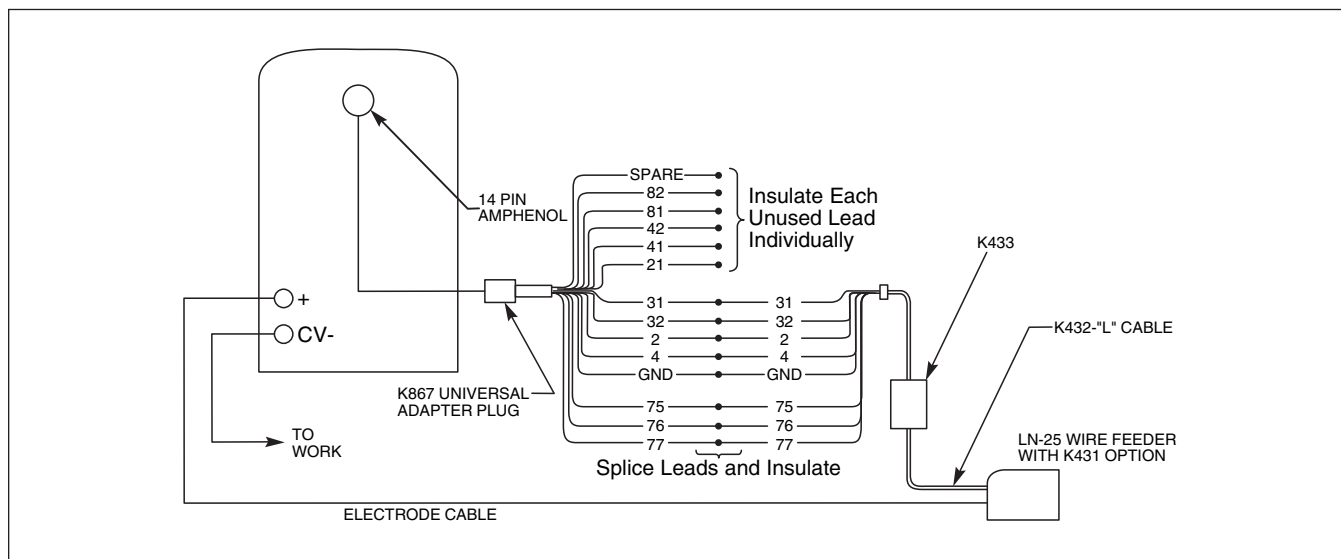

Classic III and IIID



ACCESSORIES

CONNECTION OF THE LN-25 TO THE CLASSIC III OR CLASSIC IIID (EQUIPPED WITH K623-1 WIRE FEED MODULE) "ACROSS THE ARC" (SEE FIGURE C.4.)

1. Shut the welder off.
2. Connect the electrode cable from the LN-25 to the "+" terminal of the welder. Connect the work cable to the "CV-" terminal of the welder.

NOTE: Welding cable must be sized for current and duty cycle of application.

NOTE: Figure C.4 shows the electrode connected for positive polarity. To change polarity, shut the welder off and reverse the electrode and work cables at the Classic III or Classic IIID output terminals. Reverse the

LN-25 polarity switch.

3. Connect the K444-2 remote control cable to the 14 pin amphenol on the wire feed module.
4. Attach the single lead from the LN-25 control box to the work using the spring clip on the end of the lead. This is only a control lead — it carries no welding current.
5. Place the IDLER switch in the "HIGH" position.
6. Adjust wire feed speed and voltage at the LN-25.

FIGURE C.4
CLASSIC III OR CLASSIC IIID/LN-25 ACROSS THE ARC CONNECTION DIAGRAM

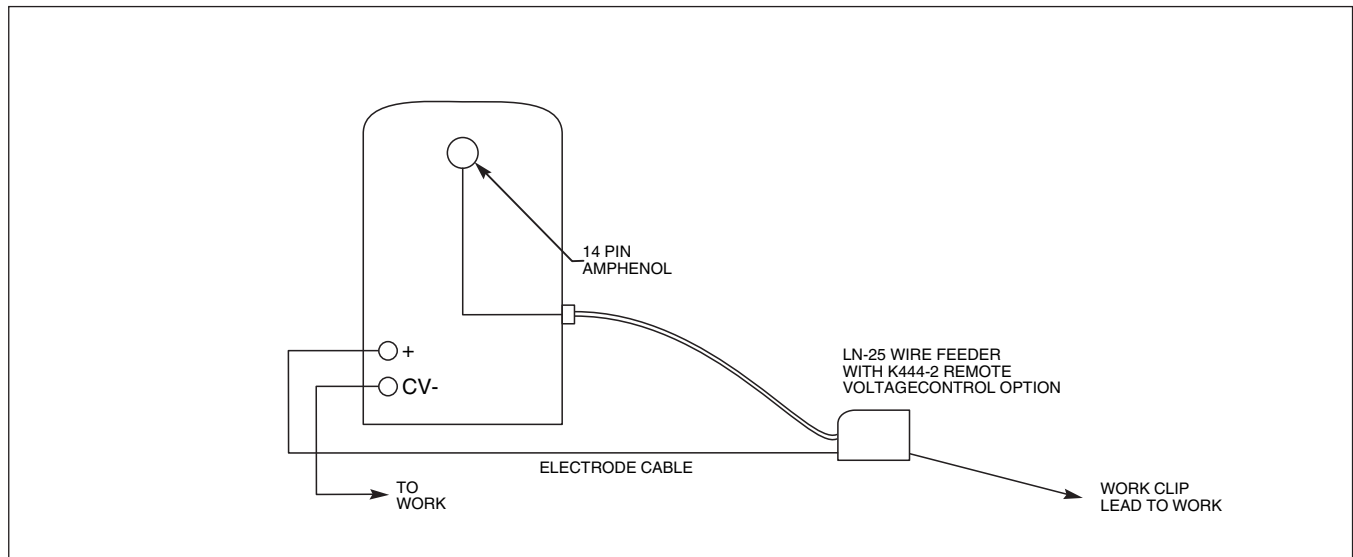

Classic III and IIID



INSTALLATION

CONNECTION OF THE LN-23P TO THE CLASSIC III OR CLASSIC IIID (EQUIPPED WITH K623-1 WIRE FEED MODULE) USING THE K-350-1 ADAPTER KIT (SEE FIGURE C.5)

1. Shut the welder off.
 2. Connect the electrode cable from the LN-23P to the "CV" output terminal of the engine welder. Connect the work cable to the "+" output terminal.
- NOTE:** Welding cable must be sized for current and duty cycle of application.
3. Mount the K350-1 adapter per instructions included with the adapter.
 4. Connect the LN-23P to the K350-1 adapter as indicated in Figure C.5. The adapter allows two wire feeders to be connected. If only one is used, connect it to Feeder "A" terminal strip.
 5. Connect the adapter cable from the K350-1 to the 14-pin amphenol on the Classic III or Classic IIID wire feed module.

WARNING

The output terminals are energized when the engine is running. The CV output will be de-energized only if WFM mode switch is in remote position.

6. Connect control lead marked "21" to the work as indicated in Figure C.5.
7. Set the CURRENT RANGE SELECTOR switch to the 190-120 (middle) position for most common processes. This may be changed if a different arc characteristic is preferred.
8. Set the LOCAL/REMOTE control toggle switch to REMOTE.
9. Set the IDLER switch to the AUTO position. The HIGH position may be required when welding with low current processes.

CAUTION

Any increase of the high idle engine RPM by changing the governor setting or overriding the throttle linkage will cause an increase in the AC auxiliary voltage. If this voltage goes over 140 volts, wire feeder control circuits may be damaged. The engine governor setting is preset at the factory — do not adjust above RPM specification listed in the manual.

FIGURE C.5
CLASSIC III OR CLASSIC IIID/LN-23P CONNECTION DIAGRAM

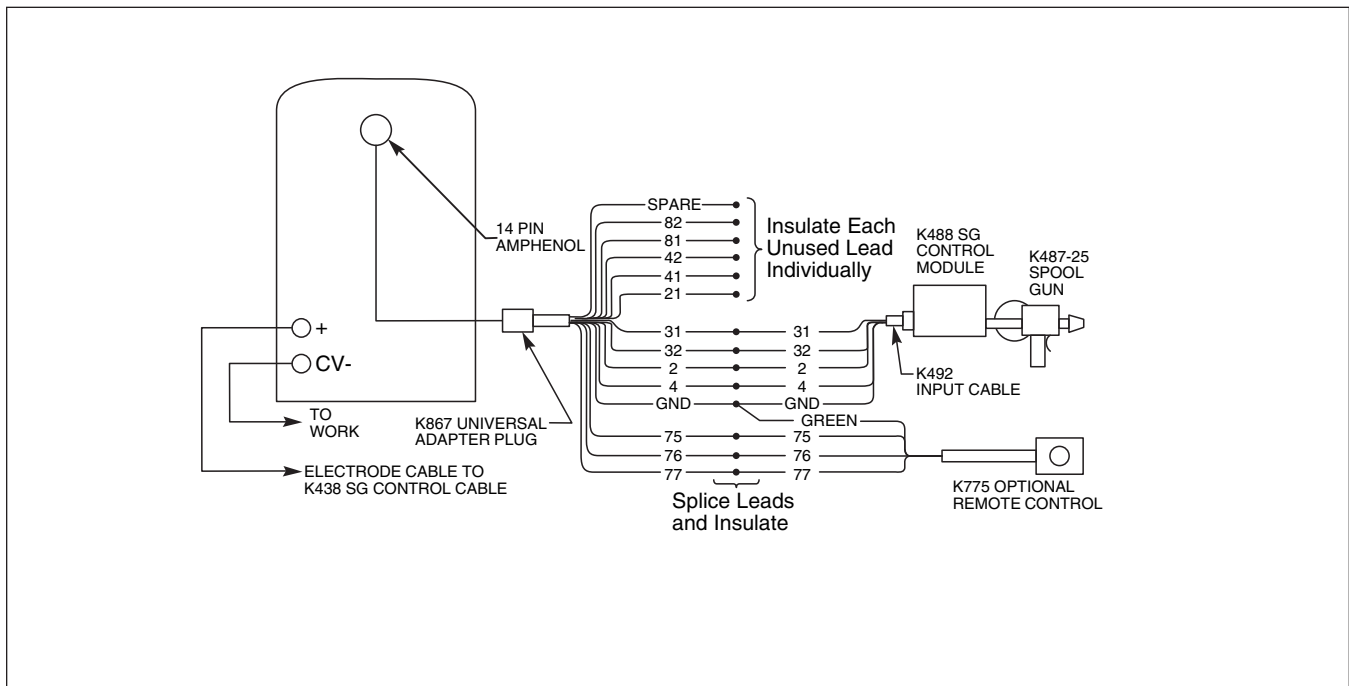

Classic III and IIID

ACCESSORIES

CONNECTION OF THE K488 SG CONTROL MODULE AND K487 MAGNUM SPOOL GUN TO THE CLASSIC III OR CLASSIC IIID (EQUIPPED WITH K623-1 WIRE FEED MODULE) (SEE FIGURE C.6.)

1. Shut the welder off.
2. Connect the electrode cable from the SG Control Module to the “+” terminal of the welder. Connect the work cable to the “CV-” terminal of the welder.

NOTE: Welding cable must be sized for current and duty cycle of application.

NOTE: Figure C.6 shows the electrode connected for positive polarity. To change polarity, shut the welder off and reverse the electrode and work cables at the Classic III or Classic IIID output terminals.

3. Connect the K867 Universal adapter to the K492 input cable as shown in Figure C.6. Connect the other end of the adapter to the 14 pin amphenol on the Classic III or Classic IIID.
4. Connect the K492 Input Cable to the SG Control Module.
5. Set the slide switch on the SG Control Module to the “Lincoln” position.

CAUTION

Be sure this switch is set to the “Lincoln” (contact closure) position before attempting to operate the SG Control Module. Incorrect switch position could result in damage to the SG Control Module and/or the Classic III or Classic IIID.

6. Place the IDLER switch on the Classic III or Classic IIID in the “HIGH” position.

CAUTION

Any increase of the high idle engine RPM by changing the governor setting or overriding the throttle linkage will cause an increase in the AC auxiliary voltage. If this voltage goes over 140 volts, wire feeder control circuits may be damaged. The engine governor setting is preset at the factory — do not adjust above RPM specifications listed in this manual.

7. Adjust wire feed speed at the SG Control Module.

NOTE: For remote control, a K775 remote control is required.

CAUTION

When the welder is in local control, the electrode is always “HOT.”

FIGURE C.6
CLASSIC III OR CLASSIC IIID/K492/K488/K487 SPOOL GUN CONNECTION DIAGRAM

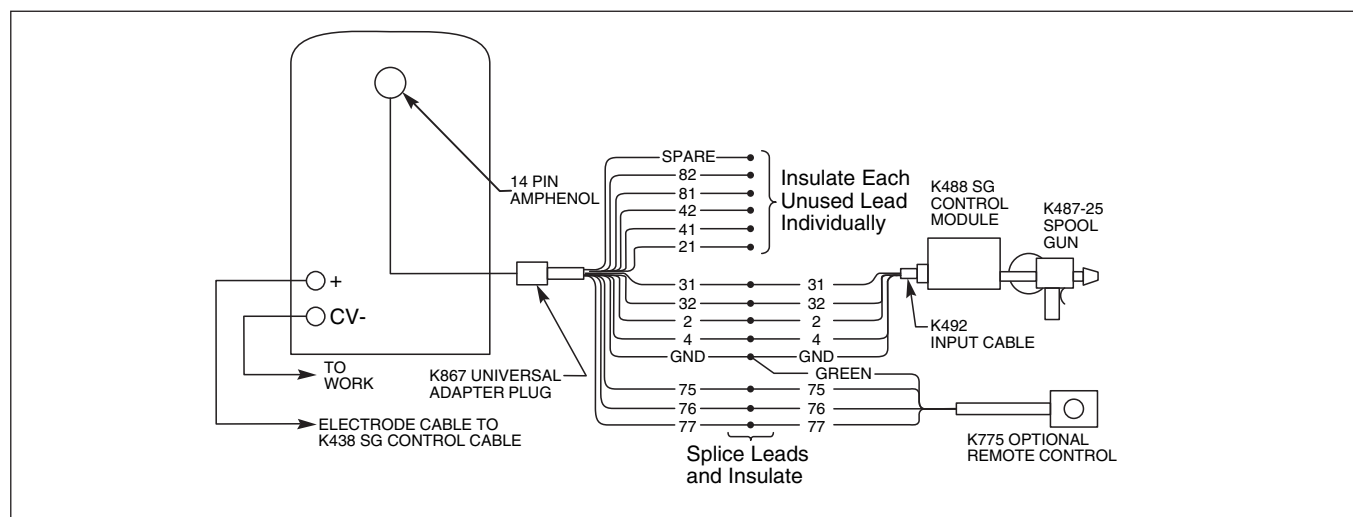

Classic III and IIID



NOTES

Return to Section TOC Return to Section TOC Return to Section TOC
Return to Master TOC Return to Master TOC Return to Master TOC

Classic III and IIID



TABLE OF CONTENTS -MAINTENANCE-

Maintenance	Section D
Safety Precautions.....	D-2
Routine and Periodic Maintenance	D-2
Engine Maintenance.....	D-2
Change the Oil	D-2
Change the Oil Filter	D-3
Fuel.....	D-3
Fuel Filter.....	D-4
Air Cleaner.....	D-4
How to Eliminate Air From the Fuel System	D-5
Cooling System.....	D-6
Spark Plugs.....	D-6
Tightening the Fan Belt.....	D-7
Engine Maintenance Schedule.....	D-8
Battery Maintenance.....	D-9
Cleaning the Battery.....	D-9
Checking Specific Gravity.....	D-9
Checking Electrolyte Level.....	D-9
Charging the Battery	D-9
Welder/Generator Maintenance	D-10
Storage.....	D-10
Cleaning	D-10
Nameplates	D-10
Commutator and Brushes.....	D-10
Bearings	D-10
Current Range Selector Contacts.....	D-10
Receptacles.....	D-10
Cable Connections.....	D-10
Idler Maintenance.....	D-11
Major Component Locations.....	D-12

Return to Master TOC

Return to Master TOC

Return to Master TOC

Return to Master TOC

MAINTENANCE

SAFETY PRECAUTIONS

WARNING

- Have qualified personnel do all maintenance and troubleshooting work.
- Turn the engine off before working inside the machine.
- Remove covers or guards only when necessary to perform maintenance and replace them when the maintenance requiring their removal is complete.
- If covers or guards are missing from the machine, get replacements from a Lincoln Distributor.

Read the Safety Precautions in the front of this manual and in the instruction manual for the engine used with your machine before working on the Classic III or Classic IIID.

Keep all equipment safety guards, covers, and devices in position and in good repair. Keep your hands, hair, clothing, and tools away from the recoil housing, fans, and all other moving parts when starting, operating, or repairing this machine.

ROUTINE AND PERIODIC MAINTENANCE

ENGINE MAINTENANCE

CAUTION

To prevent the engine from accidentally starting, disconnect the negative battery cable before servicing the engine.

See **Table D.1** for a summary of maintenance intervals for the items listed below. Follow either the hourly or the calendar intervals, whichever come first. More frequent service may be required, depending on your specific application and operating conditions.

OIL: Check the oil level after every 8 hours of operation or daily. **BE SURE TO MAINTAIN THE OIL LEVEL.**



Change the oil the first time between 25 and 50 hours of operation. Then, under normal operating conditions, change the oil as specified in **Table D.1**. If the engine is operated under heavy load or in high ambient temperatures, change the oil more frequently.

CHANGE THE OIL: Change the oil, while the engine is still warm, as follows:

1. Drain the oil from the drain plug located on the engine bottom, as shown in **Figure D.1**. If the plug is equipped with a washer, examine and replace it if it appears damaged.
2. Replace the plug and washer and tighten securely.
3. Remove the oil fill cap and add oil until the level reaches the "MAX" mark on the dipstick. See **Figure D.1**. Use high quality oil viscosity grade 10W30. Consult the engine manual for oil specifications. Always check the level with the dipstick before adding more oil.
4. Reinstall the oil fill cap and the dipstick.

Classic III and IIID



MAINTENANCE

FIGURE D.1 – OIL DRAIN AND REFILL

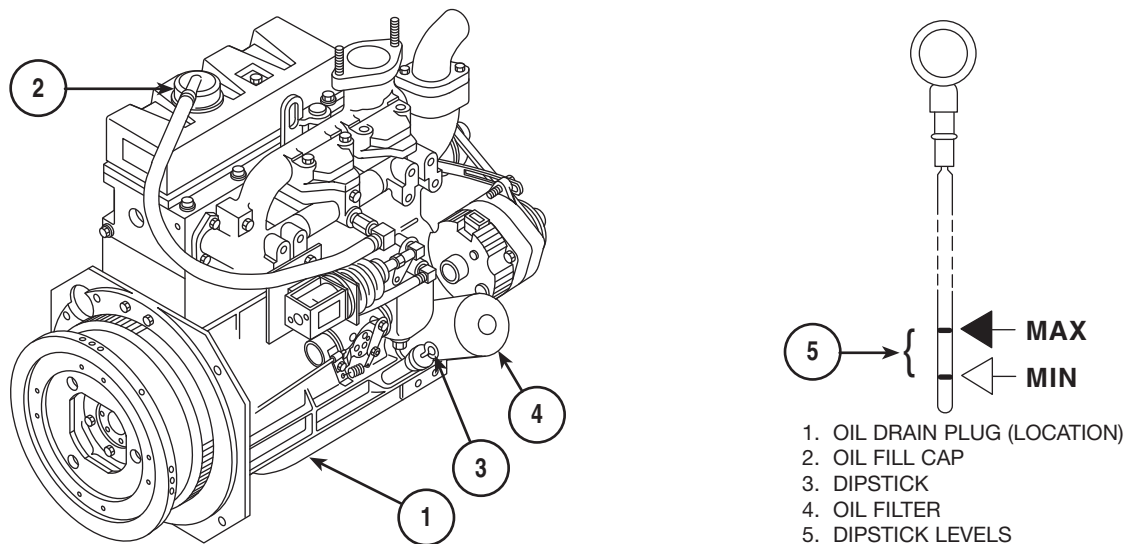

CHANGE THE OIL FILTER: Change the oil filter the first time between 25 and 50 hours of operation. Then, under normal operating conditions, change the oil filter per **Table D.1** or consult your engine Owner's Manual. If the engine is operated under heavy load or in high ambient temperatures, change the oil filter more frequently. See **Table D.1** for recommended maintenance intervals. Order Fram oil filter #PH-8A or Purolator #PER-1A from your local engine service center.

Change the oil filter as follows:

1. See Figure D.1. Remove the oil drain plug (1). Drain the oil from the engine and allow the oil filter to drain.
2. See Figure D.1. Remove the old filter (spin it off) and discard it (2). Wipe off the filter mounting surface and adapter.
3. Fill the new filter with fresh engine oil. Apply a thin coat of new oil to the rubber gasket on the new oil filter.
4. Spin the new filter onto the mounting adapter finger tight until the gasket is evenly seated. Then turn it down another 1/2 turn. Do not overtighten the new filter.

5. Refill the engine with the proper amount and type of oil as described in the **Change the Oil** section, above. Start the engine and check for leaks around the filter element. Correct any leaks (usually by retightening the filter, but only enough to stop leaks) before placing the Classic III or Classic IIID back in service.
6. See Figure D.1. If there are no leaks, stop the engine and recheck the oil level. If necessary, add oil to bring the level up to the "MAX" mark, but do not overfill.

FUEL: At the end of each day's use, refill the fuel tank to minimize moisture condensation and dirt contamination in the fuel line. Do not overfill; leave room for the fuel to expand.



Refer to your engine Owner's Manual for recommended grade of fuel.

Classic III and IIID



MAINTENANCE

FUEL FILTER - DIESEL ENGINE (CLASSIC IIID CODES ABOVE 10061 WITH STANADYNE FUEL FILTER):

The diesel engine fuel filter is a metal canister element type. It cannot be cleaned. Replace the filter per **Table D.1** or if there is reason to believe it is plugged. Change the fuel filter as follows:

1. See Figure D.2. Release the two spring clamps (1).
2. Pull the old element (2) off the filter bracket.
3. Lube the grommets on the new element with clean diesel fuel and push the element into place.
4. Snap the two spring clamps into position.
5. Bleed the air from the fuel system. See **How to Eliminate Air from the Fuel System**.

Order Continental fuel filter from your local Continental Service Center (diesel - Classic IIID). See **Table D.1** notes 5 and 6.

NOTE: If your fuel filter is not a Stanadyne filter, refer to engine Owner's Manual.

AIR CLEANER: The engine is equipped with a dry type air filter. Inspect the air cleaner daily - more often in dusty conditions. Never apply oil to the air cleaner. Service the air cleaner as follows:

1. Remove the dust cup from the bottom of the air cleaner housing. Clean out any accumulated dust.
2. Loosen the wing nut and remove the filter element.
3. If dust is sticking to the dust collector element, blow compressed air through it from the inside out. Turn the element as you apply air. Air pressure should be under 30 psi.
4. Check the element for damage before reassembling the air cleaner. Replace the element if it appears damaged. Order Donaldson element part #P181050 or Nelson #70206N.

FIGURE D.2 – FUEL FILTER REPLACEMENT

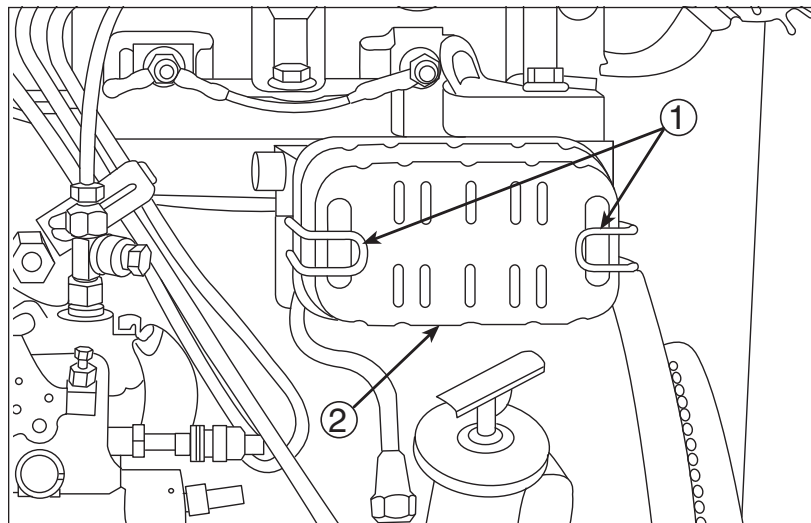

Classic III and IIID



MAINTENANCE

HOW TO ELIMINATE AIR FROM THE FUEL SYSTEM – DIESEL ENGINE (CLASSIC IIID)

The following procedure is for Classic IIID diesel engines with a Stanadyne type fuel filter (**Figure D.2**). If your filter is different, refer to your engine Owner's Manual for the correct procedure for eliminating air from the system.

1. Set the IDLER switch to HIGH and turn the ignition switch ON.
2. See Figure D.3. Loosen the fuel filter outlet connection "A" and allow fuel to flow until it is free of air.

NOTE: For this step, if connection "A" is inaccessible, due to the type of filter used, loosen connection "B" at the fuel injection pump. Also loosen connection "B" instead of "A" if "B" is higher than "A".

3. Loosen any two injector high pressure pipe nuts at the end of the injectors.
4. Press the START pushbutton and crank the engine until fuel free of air flows from the injector pipe nuts. Tighten the nuts.
5. Energize the glow plugs, then start the engine.

FIGURE D.3 – ELIMINATING AIR FROM THE FUEL SYSTEM

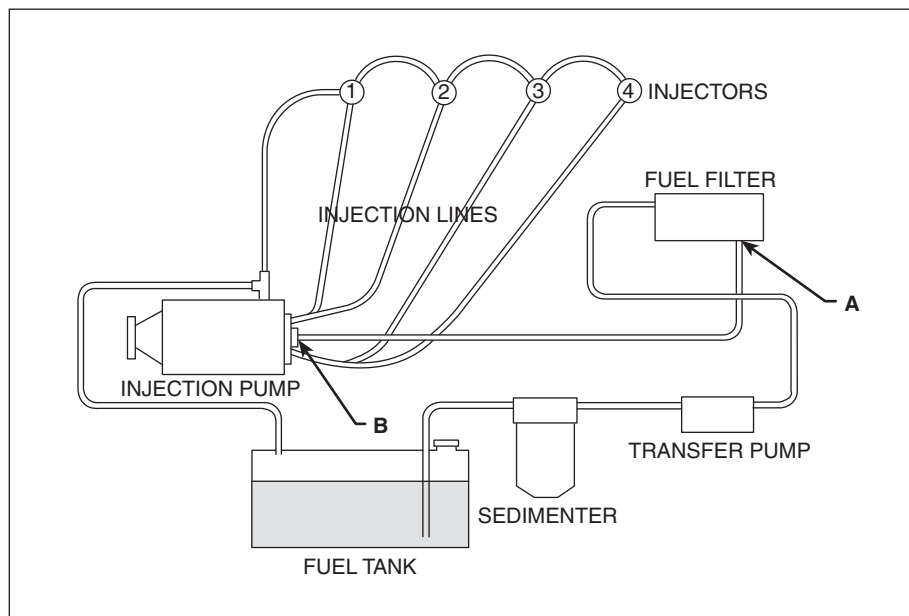

Classic III and IIID



MAINTENANCE

FIGURE D.4 – ENGINE COOLANT DRAIN PLUG AND RADIATOR DRAIN COCK

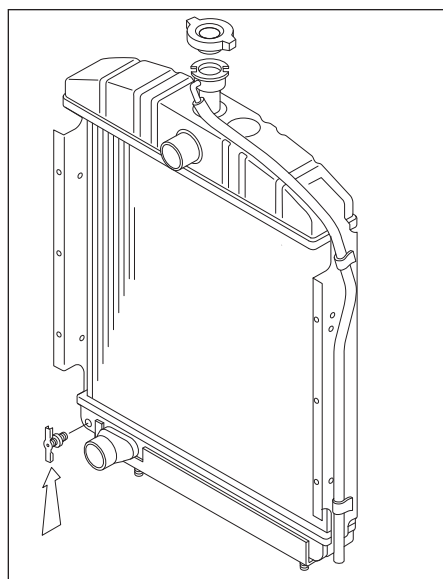
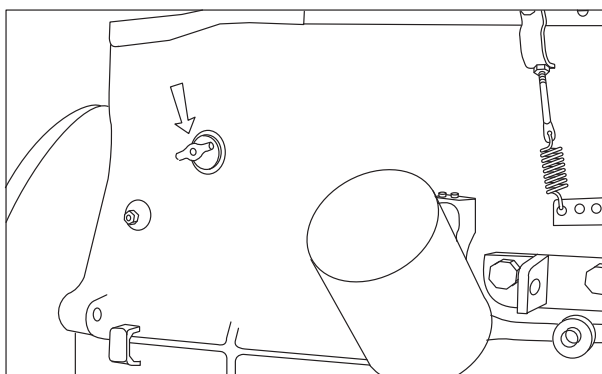

COOLING SYSTEM: The Continental engine, gasoline or diesel, is water cooled. Check the coolant level at the radiator filler daily. Add a 50-50 mixture of water and antifreeze as needed. To drain and refill the system, do the following:

1. Ensure that the machine is on level ground.

WARNING

To avoid personal injury, never remove the radiator pressure cap nor the reserve tank cap while the engine is running or immediately after it has stopped. Hot water may gush out, which can scald people nearby.

2. Remove the radiator filler cap.
3. Remove the drain plug from the side of the cylinder block in order to drain the engine. Ensure that the drain hole is not restricted. See Figure D.4.
4. Open the radiator drain cock at the bottom of the radiator in order to drain the radiator.
5. If necessary, flush the system with clean water.
6. Fit the engine drain plug and the radiator drain cock.
7. Fill the cooling system at the radiator filler with a 50-50 mixture of water and antifreeze.

SPARK PLUGS (Gasoline Engine - Classic III): Clean or replace the spark plugs after every 250 hours of operation as follows.

1. Before removing the plugs, clean the base area to keep dirt from falling into the engine through the plug hole.
2. Remove and inspect the plugs. Plugs showing signs of fouling or electrode wear should be replaced. Do not blast the spark plugs clean with an abrasive cleaning device. Clean the plugs by scraping or by using a wire brush. Wash the plugs with a commercial solvent.
3. After cleaning or when installing a new spark plug, set the terminal gap with a feeler gauge or gapping tool. See Figure D.5.

Gap Specifications: 0.032 inch (.8 mm).

4. Tighten plugs to 30 ft·lbs (40 N·m).

FIGURE D.5 – SET SPARK PLUG GAP

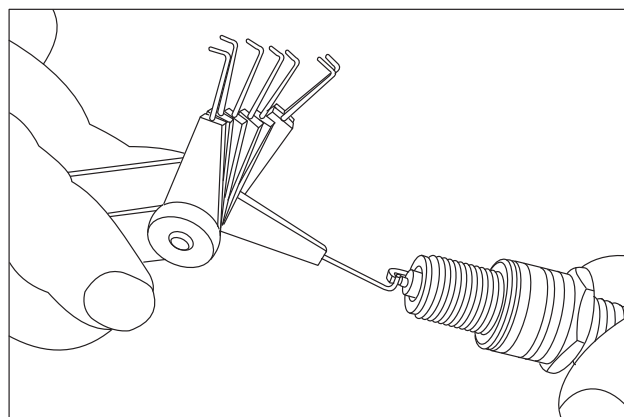

Classic III and IIID



MAINTENANCE

TIGHTENING THE FAN BELT: Fan belts tend to loosen after the first 50 hours of operation. If the fan belts are loose, the engine can overheat and the battery can lose its charge. Check belt tightness by pressing on the belt midway between the pulleys. The belt should deflect no more than 13 mm (0.5 in.). See Figure D.6.

To adjust the fan belt, do the following:

1. See Figure D.6. Loosen the pivot fasteners of the alternator (1) and the adjustment link fasteners (2).

2. Change the position of the alternator to give the correct tension. Tighten the pivot fasteners of the alternator and the adjustment link fasteners.
3. Check the belt tension again to ensure that it is still correct.

If a new belt is fitted, the belt tension must be checked again after the first 25 hours of operation.

FIGURE D.6 – TIGHTENING THE FAN BELT

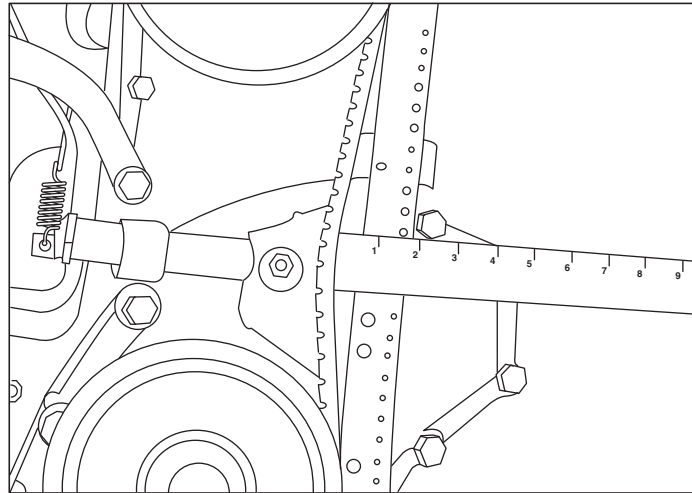

MAINTENANCE

**TABLE D.1
ENGINE MAINTENANCE SCHEDULE**

HOURS BETWEEN SERVICING				MAINTENANCE ITEM	TYPE OR CAPACITY
DAILY	50	250	500		
I				Engine Oil (1)	
	R			Engine Oil (1)	7 Qts. (Including Filter)
	R			Oil Filter	Fram #PH-8A Purolator #PER-1A
I				Air Cleaner	
	C			Air Cleaner	
		R		Air Cleaner Cartridge	Donaldson #P181050 Nelson #70206N
	C			PCV System	
	I			Fan Belt Tension	
		C		Throttle or Governor Linkage	
		C or R		Spark Plugs (Gap = .032") (4)	Champion #RN12YC
I				Cooling System	
			C	Cooling System	9.3 Qts.
			R	Fuel Filter (4)	Lincoln #S17753 (2)
			R	Fuel Filter (5)	Continental #TMD27F00506
			R	Fuel Filter (6)	Continental #TMD20F00400
	(3)		I	Valve Clearance	Intake = .014"; Exhaust = .018"
			I	Battery	BCI Group 24

I = Inspect C = Clean R = Replace

NOTES:

- (1) Consult engine Owner's Manual for all recommendations.
- (2) Or Equivalent.
- (3) First inspection after 50 hours; every 500 thereafter.
- (4) Gasoline engine only.
- (5) Diesel engine only. (Welder Code Numbers 10061 and below)
- (6) Diesel engine only. (Welder Code Numbers above 10061)
- (7) Consult Engine Owner's Manual for additional maintenance schedule information.

Classic III and IIID



MAINTENANCE

BATTERY MAINTENANCE

WARNING



GASES FROM BATTERY can explode.

- Keep sparks, flame, and cigarettes away from battery.

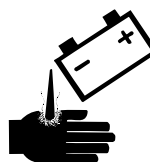

BATTERY ACID can burn eyes and skin.

- Wear gloves and eye protection and be careful when working near a battery. Follow the instructions printed on the battery.

To prevent EXPLOSION when:

- **INSTALLING A NEW BATTERY** - Disconnect the negative cable from the old battery first and connect to the new battery last.
- **THE CORRECT POLARITY IS NEGATIVE GROUND** - Damage to the engine alternator and the printed circuit board can result from incorrect connection.

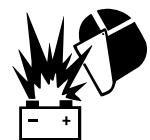

- **CONNECTING A BATTERY CHARGER** - Remove the battery from the welder by disconnecting the negative cable first, then the positive cable and battery clamp. When reinstalling, connect the negative cable last. Keep the area well ventilated.

- **USING A BOOSTER** - Connect the positive lead to the battery first, then connect the negative lead to the engine foot.
- To prevent BATTERY BUCKLING, tighten the nuts on the battery clamp until snug.

CLEANING THE BATTERY

Keep the battery clean by wiping it with a damp cloth when dirty. If the terminals appear corroded, disconnect the battery cables and wash the terminals with an ammonia solution or a solution of 1/4 pound (0.113 kg) of baking soda and 1 quart (0.946 l) of water. Be sure the battery vent plugs (if equipped) are tight so that none of the solution enters the cells.

After cleaning, flush the outside of the battery, the battery compartment, and surrounding areas with clear water. Coat the battery terminals lightly with petroleum jelly or a non-conductive grease to retard corrosion.

Keep the battery clean and dry. Moisture accumulation on the battery can lead to more rapid discharge and early battery failure.

CHECKING SPECIFIC GRAVITY

Check each battery cell with a hydrometer. A fully charged battery will have a specific gravity of 1.260. Charge the battery if the reading is below 1.215.

NOTE: Correct the specific gravity reading by adding four gravity points (0.004) for every five degrees the electrolyte temperature is above 80 degrees F (27 degrees C). Subtract four gravity points (.004) for every five degrees the electrolyte temperature is below 80 degrees F (27 degrees C).

CHECKING ELECTROLYTE LEVEL

If battery cells are low, fill them to the neck of the filler hole with distilled water and recharge. If one cell is low, check for leaks.

CHARGING THE BATTERY

The Classic III and Classic IIID are equipped with a wet charged battery. The charging current is automatically regulated when the battery is low (after starting the engine) to a trickle current when the battery is fully charged.

When you charge, jump, replace, or otherwise connect battery cables to the battery, be sure the polarity is correct. Improper polarity can damage the charging circuit. **The charging system is NEGATIVE GROUND.** The positive (+) battery terminal has a red terminal cover.

If you need to charge the battery with an external charger, disconnect the negative cable first, then the positive cable before you attach the charger leads. After the battery is charged, reconnect the positive battery cable first and the negative cable last. Failure to do so can result in damage to the internal charger components.

Follow the instructions of the battery charger manufacturer for proper charger settings and charging time.

Classic III and IIID



WELDER/GENERATOR MAINTENANCE

STORAGE: Store the Classic III or Classic IIID in clean, dry, protected areas.

CLEANING: Blow out the generator and controls periodically with low pressure air. Do this at least once a week in particularly dirty areas.

NAMEPLATES: Whenever routine maintenance is performed on this machine - or at least yearly - inspect all nameplates and labels for legibility. Replace those which are no longer clear. Refer to the parts list for the replacement item number.

COMMUTATOR AND BRUSHES: The generator brushes are properly adjusted when the welder is shipped. They require no particular attention.



CAUTION

DO NOT SHIFT THE BRUSHES or adjust the rocker setting.

Shifting of the brushes may result in:

- Change in machine output
- Commutator damage
- Excessive brush wear

Periodically inspect the DC generator commutator, AC exciter slip rings, and brushes by removing the covers. DO NOT remove these covers while the machine is running.

Commutators and brushes require little attention. However, if they are black or appear uneven, have them cleaned by experienced maintenance personnel using a commutator stone. Never use emery cloth or paper for this purpose.

Replace brushes when they wear within 1/4" of the pigtail. A complete set of replacement brushes should be kept on hand. Lincoln brushes have a curved face to fit the commutator. Have experienced maintenance personnel seat these brushes by lightly stoning the commutator as the armature rotates at full speed until contact is made across the full face of the brushes. After stoning, blow out the dust with low pressure air.

Seat the brushes on the AC exciter as follows. Position the brushes in place. Then slide one end of a piece of fine sandpaper between slip rings and brushes with the coarse side against the brushes. With slight additional finger pressure on top of the brushes, pull the sandpaper around the circumference of the rings - in direction of rotation only - until brushes seat

properly. In addition, stone slip ring with a fine stone. Brushes must be seated 100%.

Arcing or excessive exciter brush wear indicates a possible misaligned shaft.



WARNING

Uncovered rotating equipment can be dangerous. Use care so your hands, hair, clothing or tools do not catch in the rotating parts. Protect yourself from particles that may be thrown out by the rotating armature when stoning the commutator.

Arcing or excessive exciter brush wear indicates a possible misaligned shaft. Have an authorized Lincoln Electric Field Service facility check and realign the shaft.

BEARINGS: The Classic III and Classic IIID are equipped with double-shielded ball bearings having sufficient grease to last indefinitely under normal service. Where the welder is used constantly or in excessively dirty locations, it may be necessary to add one half ounce of grease per year. A pad of grease one inch wide, one inch long, and one inch high weighs approximately one half ounce. Over-greasing is far worse than insufficient greasing.

When greasing the bearings, keep all dirt out of the area. Wipe the fittings completely clean and use clean equipment. More bearing failures are caused by dirt introduced during greasing than from insufficient grease.

CURRENT RANGE SELECTOR CONTACTS: The contacts should not be greased. To keep the contacts clean, rotate the current control handle through its entire range frequently. Good practice is to turn the handle from maximum to minimum setting twice each morning before starting to weld. Never rotate the handle while the machine is under load.

Put a drop of oil on the CURRENT RANGE SELECTOR shaft at least once every month.

RECEPTACLES: Keep the electrical receptacles in good condition. Remove any dirt, oil, or other debris from their surfaces and holes.

CABLE CONNECTIONS: Check the welding cable connections at the weld output terminals often. Be sure that the connections are always tight.

Classic III and IIID



MAINTENANCE

IDLER MAINTENANCE

1. The solenoid plunger must work freely because binding can cause engine surging. If surging occurs, be sure the plunger is properly lined up with the throttle lever. Dust the plunger about once a year with graphite powder.
2. When any service is done, reassemble the rubber bellows on the solenoid plunger with the vent hole on the lower side.
3. Proper operation of the idler requires good grounding of the printed circuit board (through its mounting), reed switch and battery.
4. If desired, the welder can be used without automatic idling by setting the IDLER switch to the HIGH position.

MAINTENANCE

**FIGURE D.7 - MAJOR COMPONENT LOCATIONS
(CLASSIC IIIID SHOWN)**

1. RIGHT CASE SIDE (DOOR)
2. BASE (WITH BATTERY)
3. ALTERNATOR BRUSHES
4. ALTERNATOR
5. GENERATOR
6. GENERATOR BRUSHES
7. OUTPUT TERMINALS
8. FUEL TANK
9. CASE FRONT WITH CONTROL PANEL
10. LEFT CASE SIDE
11. CASE TOP
12. CASE BACK WITH RADIATOR
13. COOLING FAN
14. AIR CLEANER
15. IDLER CONTROL

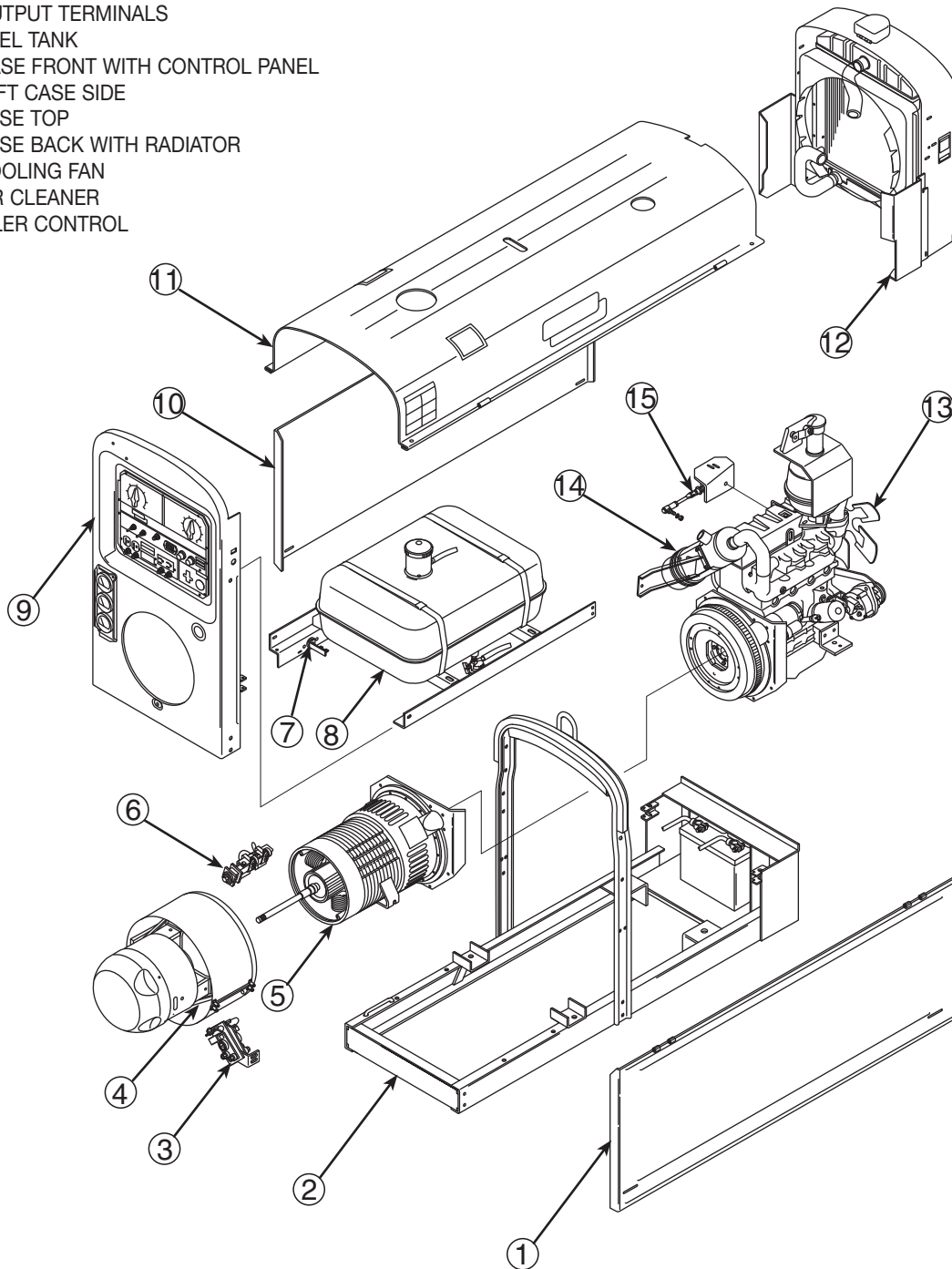

Classic III and IIIID



NOTES

Return to Section TOC Return to Section TOC Return to Section TOC
Return to Master TOC Return to Master TOC Return to Master TOC

Classic III and IIID



NOTES

Return to Section TOC Return to Section TOC Return to Section TOC
Return to Master TOC Return to Master TOC Return to Master TOC

Classic III and IIID



TABLE OF CONTENTS -THEORY OF OPERATION SECTION-

Theory of OperationSection E

- General DescriptionE-2
- Battery, Starter, Engine Alternator and Oil Switch Circuits (Classic III).....E-3
- Battery, Starter, Engine Alternator and Engine Protection Circuitry (Classic IIID).....E-4
- Engine, Generator Armature and Frame, Alternator Stator and RotorE-5
 - Excitation (Flashing)E-5
 - Auxiliary and Field Feedback Coils.....E-5
 - Interpole and Series Coils.....E-5
 - Current Range Selector.....E-6
 - Fine Current AdjustmentE-6
 - Engine Idler Circuit.....E-6
- DC Generator Machines.....E-7

Return to Master TOC

Return to Master TOC

Return to Master TOC

Return to Master TOC



FIGURE E.2a – BATTERY, STARTER, ENGINE ALTERNATOR AND OIL SWITCH CIRCUIT (CLASSIC III)

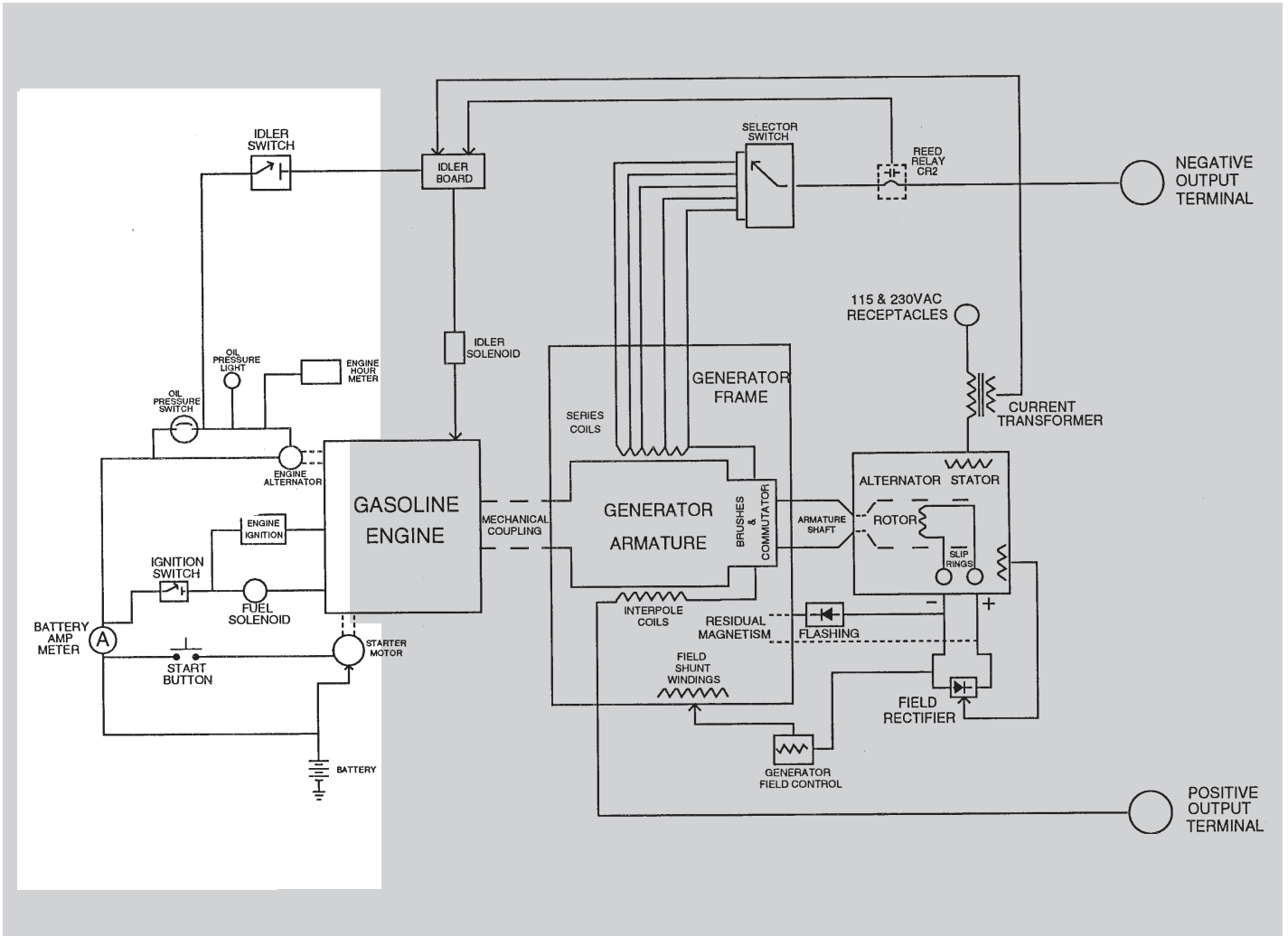

BATTERY, STARTER, ENGINE ALTERNATOR AND OIL SWITCH CIRCUIT (CLASSIC III)

The 12VDC battery powers the starter motor and, through the ignition switch, the engine ignition and fuel shutoff solenoid. The engine alternator supplies “charging” current for the battery circuit. If the oil pressure switch does not close, due to low oil pressure or inadequate oil supply, the oil pressure light will not glow, the hour meter will not operate and the engine alternator and automatic idler will not function

NOTE: Unshaded areas of Block Logic Diagram are the subject of discussion.

Classic III and IIID



Return to Section TOC
Return to Master TOC
Return to Section TOC
Return to Master TOC
Return to Section TOC
Return to Master TOC
Return to Section TOC
Return to Master TOC

THEORY OF OPERATION

FIGURE E.2b – BATTERY, STARTER, ENGINE ALTERNATOR AND ENGINE PROTECTION CIRCUITRY (CLASSIC IIID)

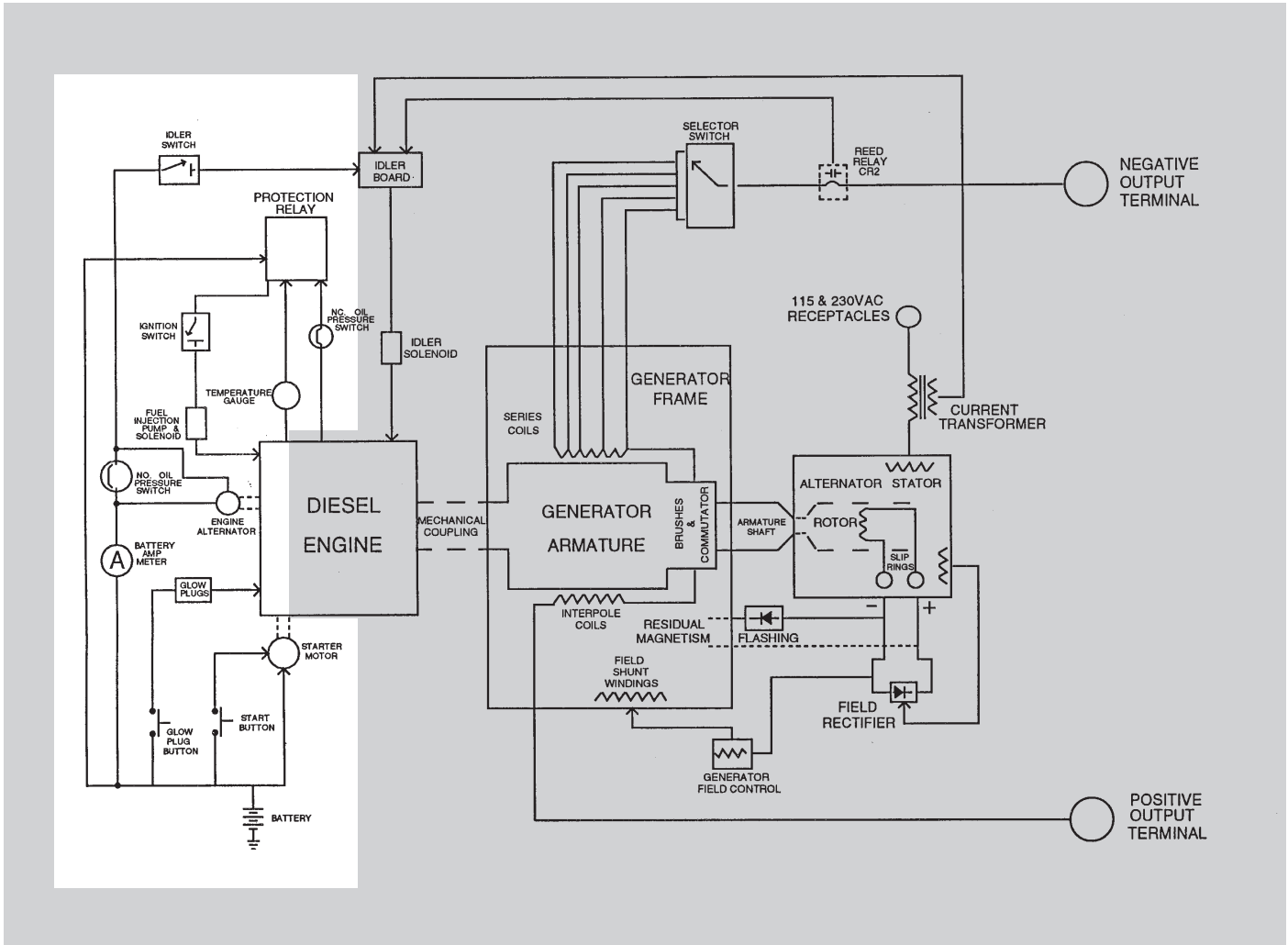

BATTERY, STARTER, ENGINE ALTERNATOR AND PROTECTION CIRCUITRY (CLASSIC IIID)

The 12VDC battery powers the starter motor, glow plugs and the engine protection circuitry. The fuel pump and solenoid are powered from the protection circuit through the ignition switch. In the event of a low oil pressure or high oil temperature condition, the engine protection system will shut down the engine by removing power from the fuel solenoid and lift pump. If the normally open oil pressure switch does not close, due to low pressure or inadequate oil supply, the engine alternator and automatic idler circuit will not function.

NOTE: Unshaded areas of Block Logic Diagram are the subject of discussion.

Classic III and IIID



Return to Section TOC
Return to Master TOC
Return to Section TOC
Return to Master TOC
Return to Section TOC
Return to Master TOC
Return to Section TOC
Return to Master TOC

THEORY OF OPERATION

FIGURE E.3 – ENGINE, GENERATOR ARMATURE AND FRAME, ALTERNATOR STATOR AND ROTOR (CLASSIC III)

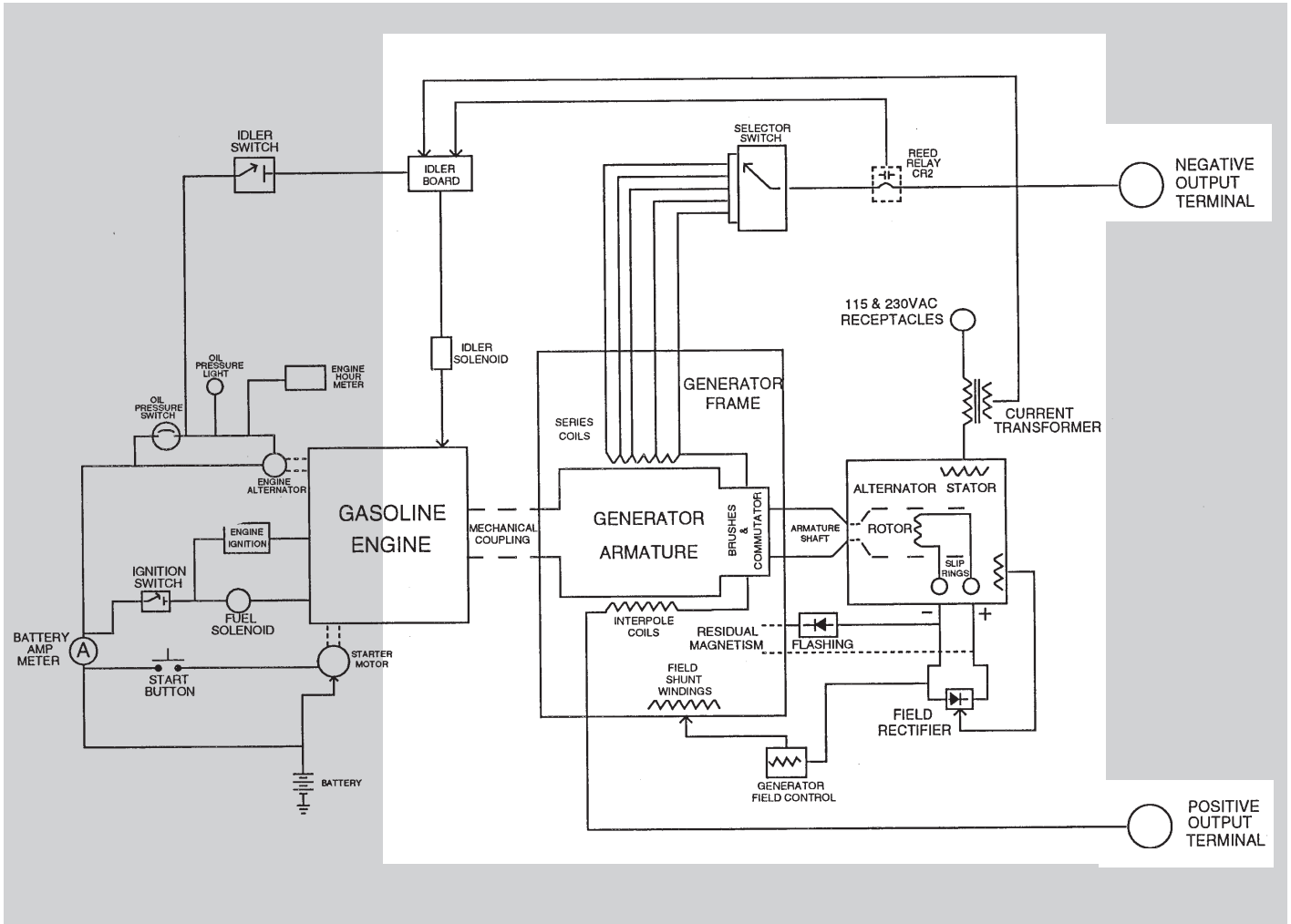

NOTE: Unshaded areas of Block Logic Diagram are the subject of discussion.

ENGINE, GENERATOR ARMATURE AND FRAME, ALTERNATOR STATOR AND ROTOR EXCITATION (FLASHING)

When the engine is started and running, the residual magnetism voltage is applied to the alternator rotor through a brush and slip ring configuration. This excitation (“flashing”) voltage magnetizes the rotor lamination. The alternator rotor is connected to the armature shaft, which is mechanically coupled to the engine. This rotating magnet (rotor) induces a voltage in the stationary windings of the alternator stator.

AUXILIARY AND FIELD FEEDBACK COILS

There are two isolated windings incorporated in the stator lamination assembly. One of these windings is tapped and provides 115VAC and 230VAC of auxiliary power to the appropriate receptacles. The other

115VAC isolated winding is rectified to a DC voltage. It supplies field feedback voltage to the rotor. It also supplies exciter voltage to the field shunt windings in the main generator frame. This voltage is controlled by the generator field control.

INTERPOLE AND SERIES COILS

The generator armature rotates within the magnetic field created by the field shunt windings. A voltage is induced in the armature and transferred, through the armature commutator and brushes, to the series and interpole coils. The interpole coils, which are connected in series with the positive output terminal, are located so as to counteract any magnetic influences that could cause distortion in the rotating field. The series coils are designed to oppose or “buck” the DC voltage generated by the armature.

Classic III and IIID



THEORY OF OPERATION

CURRENT RANGE SELECTOR

The selector switch acts as a coarse current adjustment by allowing varying amounts of series windings to be included in the welding current path. The series coils and selector switch are connected in series with the negative output terminal.

FINE CURRENT ADJUSTMENT

The field rheostat control functions as a fine output current adjustment. By controlling the current through the shunt windings, it controls the amount of magnetism created in the shunt field windings. Open circuit weld voltage is also controlled by the field rheostat control.

ENGINE IDLER CIRCUIT

The idler solenoid is mechanically connected to the engine governor linkage. When welding current is being drawn, the reed switch CR2 is closed. This signals the idler PC board to release (deactivate) the idler solenoid, which then lets the machine go to a high speed condition. Also, when auxiliary power is being used, the current is passed through the current transformer. This signals the idler PC board to release the idler solenoid.

When welding ceases or the auxiliary load is removed, a preset time delay of about 15 seconds starts. After approximately 15 seconds, the idler PC board activates the idler solenoid, and the machine returns to a low speed condition.

Classic III and IIID



Return to Section TOC
Return to Master TOC
Return to Section TOC
Return to Master TOC
Return to Section TOC
Return to Master TOC
Return to Section TOC
Return to Master TOC

THEORY OF OPERATION

FIGURE E.4 – DC GENERATOR MACHINES

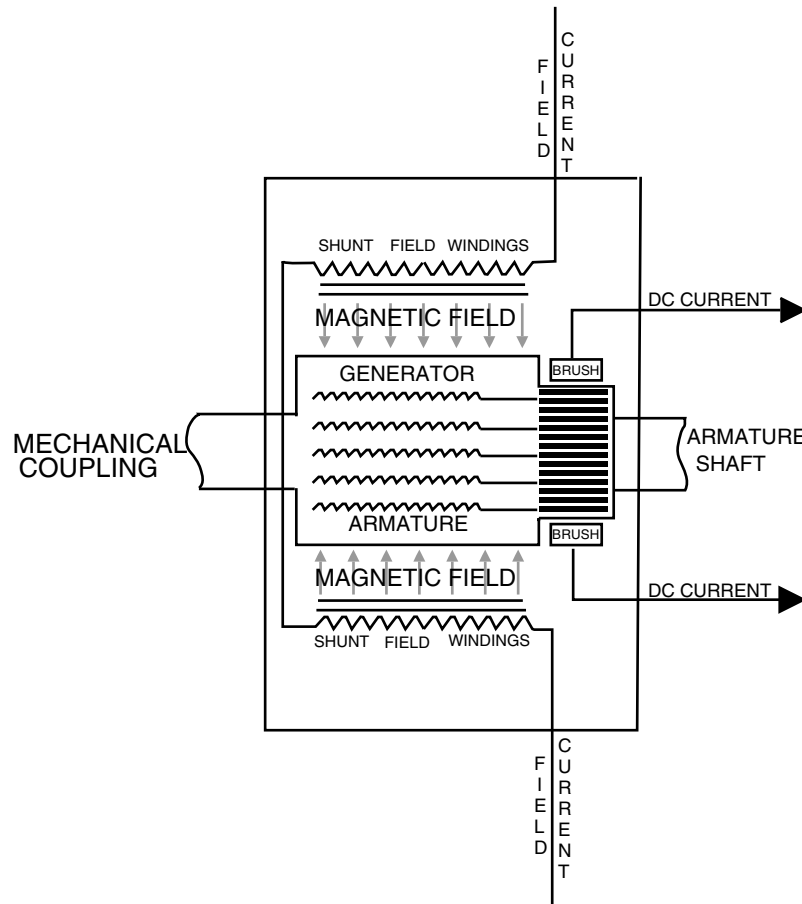

DC GENERATOR MACHINES

The armature winding of a DC generator is located on the rotating member. Current is conducted from it by means of carbon brushes. The field winding is located in the stator, which is stationary, and is excited by direct current.

The armature coil sides are placed at opposite points on the rotating shaft with the conductors parallel to the shaft. The armature assembly is normally turned at a constant speed by a source of mechanical power connected to the shaft. Rotation of the armature through the magnetic field produced by the stationary field

winding induces a coil voltage in the armature winding. The voltage induced in an individual armature coil is an alternating (AC) voltage, which must be rectified. In a conventional DC Generator, rectification is provided mechanically by means of a commutator. A commutator is a cylinder formed of copper segments insulated from each other and mounted on, but insulated from, the rotating shaft. Stationary carbon brushes held against the commutator surface connect the armature windings to external terminals. The commutator provides full-wave rectification, transforming the voltage waveform between brushes and making a DC voltage available to the external circuit.

Classic III and IIID



NOTES

Return to Section TOC
Return to Master TOC
Return to Section TOC
Return to Master TOC
Return to Section TOC
Return to Master TOC
Return to Section TOC
Return to Master TOC
Return to Section TOC
Return to Master TOC

Classic III and IIID



TABLE OF CONTENTS

TROUBLESHOOTING & REPAIR SECTION

Troubleshooting & Repair Section.....	Section F
How to Use Troubleshooting Guide	F-2
PC Board Troubleshooting Procedures	F-3
Troubleshooting Guide.....	F-4 - F-13
Test Procedures	F-14
Alternator Rotor Test	F-14
Field Shunt Winding Test	F-18
Flashing the Fields	F-21
Idle Solenoid Test.....	F-23
Engine Throttle Adjustment Test - Classic IIID (Diesel).....	F-25
Engine Throttle Adjustment Test - Classic III (Gasoline).....	F-29
Oscilloscope Waveforms	F-34
Normal Open Circuit Voltage Waveform (115VAC Supply).....	F-34
Normal Open Circuit DC Weld Voltage Waveform.....	F-35
Typical DC Weld Output Voltage Waveform.....	F-36
Replacement Procedures	F-37
Alternator Rotor Removal and Replacement	F-37
Alternator Stator Removal and Replacement	F-42
Generator Frame Removal and Replacement	F-47
Generator Armature Removal and Replacement.....	F-53
Retest After Repair	F-55

TROUBLESHOOTING & REPAIR

HOW TO USE TROUBLESHOOTING GUIDE

WARNING

Service and repair should be performed by only Lincoln Electric Factory Trained Personnel. Unauthorized repairs performed on this equipment may result in danger to the technician and machine operator and will invalidate your factory warranty. For your safety and to avoid Electrical Shock, please observe all safety notes and precautions detailed throughout this manual.

This Troubleshooting Guide is provided to help you locate and repair possible machine malfunctions. Simply follow the three-step procedure listed below.

Step 1. LOCATE PROBLEM (SYMPTOM). Look under the column labeled “PROBLEM” (SYMPTOMS). This column describes possible symptoms that the machine may exhibit. Find the listing that best describes the symptom that the machine is exhibiting. Symptoms are grouped into four main categories: Output Problems, Function Problems, Engine Problems and Welding Problems.

Step 2. PERFORM EXTERNAL TESTS. The second column, labeled “POSSIBLE AREAS OF MISADJUSTMENT(S)”, lists the obvious external possibilities that may contribute to the machine symptom. Perform these tests/checks in the order listed. In general, these tests can be conducted without removing the case wrap-around cover.

Step 3. PERFORM COMPONENT TESTS. The last column, labeled “Recommended Course of Action” lists the most likely components that may have failed in your machine. It also specifies the appropriate test procedure to verify that the subject component is either good or bad. If there are a number of possible components, check the components in the order listed to eliminate one possibility at a time until you locate the cause of your problem.

All of the referenced test procedures referred to in the Troubleshooting Guide are described in detail at the end of this chapter. Refer to the Troubleshooting and Repair Table of Contents to locate each specific Test Procedure. All of the referred to test points, components, terminal strips, etc., can be found on the referenced electrical wiring diagrams and schematics. Refer to the Electrical Diagrams Section Table of Contents to locate the appropriate diagram.

CAUTION

If for any reason you do not understand the test procedures or are unable to perform the test/repairs safely, contact the Lincoln Electric Service Department for electrical troubleshooting assistance before you proceed. Call 216-383-2531 or 1-888-935-3877.

Classic III and IIID



TROUBLESHOOTING & REPAIR

PC BOARD TROUBLESHOOTING PROCEDURES

WARNING



ELECTRIC SHOCK can kill.

Have an electrician install and service this equipment. Turn the machine OFF before working on equipment. Do not touch electrically hot parts.

Sometimes machine failures appear to be due to PC board failures. These problems can sometimes be traced to poor electrical connections. To avoid problems when troubleshooting and replacing PC boards, please use the following procedure:

1. Determine to the best of your technical ability that the PC board is the most likely component causing the failure symptom.
2. Check for loose connections at the PC board to assure that the PC board is properly connected.
3. If the problem persists, replace the suspect PC board using standard practices to avoid static electrical damage and electrical shock. Read the warning inside the static resistant bag and perform the following procedures:



ATTENTION
Static-Sensitive
Devices
Handle only at
Static-Safe
Workstations

Reusable
Container
Do Not Destroy

PC Board can be damaged by static electricity.

- Remove your body's static charge before opening the static-shielding bag. Wear an anti-static wrist strap. For safety, use a 1 Meg ohm resistive cord connected to a grounded part of the equipment frame.
 - If you don't have a wrist strap, touch an unpainted, grounded, part of the equipment frame. Keep touching the frame to prevent static build-up. Be sure not to touch any electrically live parts at the same time.
- Tools which come in contact with the PC Board must be either conductive, anti-static or static-dissipative.

- Remove the PC Board from the static-shielding bag and place it directly into the equipment. Don't set the PC Board on or near paper, plastic or cloth which could have a static charge. If the PC Board can't be installed immediately, put it back in the static-shielding bag.
- If the PC Board uses protective shorting jumpers, don't remove them until installation is complete.
- If you return a PC Board to The Lincoln Electric Company for credit, it must be in the static-shielding bag. This will prevent further damage and allow proper failure analysis.

4. Test the machine to determine if the failure symptom has been corrected by the replacement PC board.

NOTE: Allow the machine to heat up so that all electrical components can reach their operating temperature.

5. Remove the replacement PC board and substitute it with the original PC board to recreate the original problem.
 - a. If the original problem does not reappear by substituting the original board, then the PC board was not the problem. Continue to look for bad connections in the control wiring harness, junction blocks, and terminal strips.
 - b. If the original problem is recreated by the substitution of the original board, then the PC board was the problem. Reinstall the replacement PC board and test the machine.

6. Always indicate that this procedure was followed when warranty reports are to be submitted.

NOTE: Following this procedure and writing on the warranty report, "INSTALLED AND SWITCHED PC BOARDS TO VERIFY PROBLEM," will help avoid denial of legitimate PC board warranty claims.

Classic III and IIID



TROUBLESHOOTING & REPAIR

Observe Safety Guidelines detailed in the beginning of this manual.

TROUBLESHOOTING GUIDE

PROBLEMS (SYMPTOMS)	POSSIBLE AREAS OF MISADJUSTMENT(S)	RECOMMENDED COURSE OF ACTION
OUTPUT PROBLEMS		
<p>The engine starts and runs at correct speed, but there is no, or very low, welder output voltage. There is no AC auxiliary output voltage.</p>	<ol style="list-style-type: none"> 1. Check the 15 amp fuse located on the inside of the front control panel. 2. If the welder output is zero volts, the fields may need to be flashed. See Flashing the Fields in this section. 3. Check for loose or missing-brushes in the exciter alternator and welding generator. 	<ol style="list-style-type: none"> 1. Check the “flashing” diode and associated leads connected between the generator brushes and the exciter alternator brushes. 2. Check the field diode bridge and associated leads and connections. See the Wiring Diagram. 3. Perform the Alternator Rotor Test. 4. Check for “opens” or shorted turns in the alternator stator windings. The coils must NOT be grounded to the stator lamination.



CAUTION

If for any reason you do not understand the test procedures or are unable to perform the test/repairs safely, contact the Lincoln Electric Service Department for electrical troubleshooting assistance before you proceed. Call 216-383-2531 or 1-888-935-3877.

Classic III and IIID



Return to Section TOC

Return to Master TOC

Return to Section TOC

Return to Master TOC

Return to Section TOC

Return to Master TOC

Return to Section TOC

Return to Master TOC

TROUBLESHOOTING & REPAIR

TROUBLESHOOTING GUIDE

Observe Safety Guidelines detailed in the beginning of this manual.

PROBLEMS (SYMPTOMS)	POSSIBLE AREAS OF MISADJUSTMENT(S)	RECOMMENDED COURSE OF ACTION
OUTPUT PROBLEMS		
<p>The engine starts and runs at correct speed, but there is no, or very low, welder output voltage. The AC auxiliary output voltage is normal.</p>	<ol style="list-style-type: none"> 1. Check for loose or missing brushes in the welding generator. 2. Check the welding cables for loose or faulty connections. 	<ol style="list-style-type: none"> 1. Check the Fine Current Adjustment rheostat for resistance and proper operation. Normal resistance is 64 ohms. Check associated wires for loose or faulty connections. See the Wiring Diagram. 2. Perform the <i>Shunt Field Winding Test</i>. 3. Check the continuity of the interpole coils. They should show continuity from the positive brush holders to the positive output terminal and should NOT be grounded to the generator frame. 4. Check the continuity of the series coils. They should show continuity from the negative brush holders, through the Current Range Selector switch, to the negative output terminal and should NOT be grounded. Also check the Selector switch for proper operation. 5. The main armature may be faulty. Check for grounds and/or shorts.

CAUTION

If for any reason you do not understand the test procedures or are unable to perform the test/repairs safely, contact the Lincoln Electric Service Department for electrical troubleshooting assistance before you proceed. Call 216-383-2531 or 1-888-935-3877.

Classic III and IIID



Return to Section TOC

Return to Master TOC

Return to Section TOC

Return to Master TOC

Return to Section TOC

Return to Master TOC

Return to Section TOC

Return to Master TOC

TROUBLESHOOTING & REPAIR

Observe Safety Guidelines detailed in the beginning of this manual.

TROUBLESHOOTING GUIDE

PROBLEMS (SYMPTOMS)	POSSIBLE AREAS OF MISADJUSTMENT(S)	RECOMMENDED COURSE OF ACTION
OUTPUT PROBLEMS		
<p>The welding output varies abnormally. The auxiliary output remains constant. The engine is operating correctly.</p>	<ol style="list-style-type: none"> 1. May be a normal condition. The machine will normally lose some output as the components get heated. 2. Check for loose, worn, dirty, or poorly seated DC generator brushes. 3. The armature commutator may need cleaning. 4. Check for loose or faulty welding cables. 	<ol style="list-style-type: none"> 1. Check the Fine Current Adjustment rheostat for resistance and proper operation. Normal resistance is 64 ohms. Check associated wires for loose or faulty connections. See the Wiring Diagram. 2. Perform the Field Shunt Winding Test. 3. Check the Current Range Selector switch and contacts for proper operation. 4. While the machine is loaded, check the interpole and series coils for signs of "arcing." This condition would point to shorted turns in the "arcing" coil. 5. The main armature may be faulty. Check for grounds.

 **CAUTION**

If for any reason you do not understand the test procedures or are unable to perform the test/repairs safely, contact the Lincoln Electric Service Department for electrical troubleshooting assistance before you proceed. Call 216-383-2531 or 1-888-935-3877.

Classic III and IIID



Return to Section TOC

Return to Master TOC

Return to Section TOC

Return to Master TOC

Return to Section TOC

Return to Master TOC

Return to Section TOC

Return to Master TOC

TROUBLESHOOTING & REPAIR

TROUBLESHOOTING GUIDE

Observe Safety Guidelines detailed in the beginning of this manual.

PROBLEMS (SYMPTOMS)	POSSIBLE AREAS OF MISADJUSTMENT(S)	RECOMMENDED COURSE OF ACTION
OUTPUT PROBLEMS		
<p>The engine starts and runs at the correct speed, but there is no AC auxiliary output voltage. The DC welding generator is functioning correctly.</p>	<ol style="list-style-type: none"> 1. Check the AC auxiliary output circuit breakers. Reset if tripped. 2. Check the 115VAC and 230VAC receptacles and plugs for loose or faulty connections. 	<ol style="list-style-type: none"> 1. Check for loose or faulty connections between the receptacles, the circuit breakers, the current transformer and the exciter alternator stator. See the Wiring Diagram. 2. Check the 115VAC and 230VAC windings in the alternator stator for shorted turns or grounds. Check the continuity of the windings. See the Wiring Diagram.
<p>The engine starts and runs normally. The machine takes a long time to “build-up” and produce output voltage. The AC auxiliary voltage varies when the Fine Current Control rheostat is adjusted.</p>	<ol style="list-style-type: none"> 1. Contact your local Authorized Field Service Facility. 	<ol style="list-style-type: none"> 1. Check the “flashing” diode located on the DC generator brush holder. The diode may be “shorted” or installed incorrectly.

 **CAUTION**

If for any reason you do not understand the test procedures or are unable to perform the test/repairs safely, contact the Lincoln Electric Service Department for electrical troubleshooting assistance before you proceed. Call 216-383-2531 or 1-888-935-3877.

Classic III and IIID



Return to Section TOC
Return to Master TOC

TROUBLESHOOTING & REPAIR

Observe Safety Guidelines detailed in the beginning of this manual.

TROUBLESHOOTING GUIDE

PROBLEMS (SYMPTOMS)	POSSIBLE AREAS OF MISADJUSTMENT(S)	RECOMMENDED COURSE OF ACTION
FUNCTION PROBLEMS		
<p>The engine will not return to low idle when the welding and auxiliary loads are removed.</p>	<ol style="list-style-type: none"> 1. Make sure the Idler Control switch is set to the "Auto" position. 2. Make sure both welding and auxiliary loads are removed. 3. Check for mechanical restrictions in the idler and throttle linkage. 	<ol style="list-style-type: none"> 1. Check the Idler Control switch and associated leads for loose or faulty connections. See the Wiring Diagram. 2. Check the reed switch CR2. It may be stuck closed. Replace if necessary. 3. Check for loose or faulty connections at the Idler PC board. 4. Make sure lead #60D is grounded correctly. See the Wiring Diagram. 5. Perform the <i>Idler Solenoid Test</i>. 6. The Idler PC board may be faulty. Replace.

 **CAUTION**

If for any reason you do not understand the test procedures or are unable to perform the test/repairs safely, contact the Lincoln Electric Service Department for electrical troubleshooting assistance before you proceed. Call 216-383-2531 or 1-888-935-3877.

 Classic III and IIID



Return to Section TOC
 Return to Section TOC
 Return to Section TOC
 Return to Section TOC
 Return to Section TOC
 Return to Section TOC

Return to Master TOC
 Return to Master TOC
 Return to Master TOC
 Return to Master TOC
 Return to Master TOC
 Return to Master TOC

TROUBLESHOOTING & REPAIR

TROUBLESHOOTING GUIDE

Observe Safety Guidelines detailed in the beginning of this manual.

PROBLEMS (SYMPTOMS)	POSSIBLE AREAS OF MISADJUSTMENT(S)	RECOMMENDED COURSE OF ACTION
FUNCTION PROBLEMS		
<p>The engine will NOT go to high speed when a load is applied to the welding output terminals. The engine does go to high speed when a load is applied to the AC auxiliary power receptacles.</p>	<ol style="list-style-type: none"> 1. Check welding cables for loose or faulty connections. 	<ol style="list-style-type: none"> 1. Check the reed switch (CR2) for proper operation. The reed switch should close when there is current flow in the welding circuit. 2. Locate the red lead connected to the Idler PC board. While leaving the red lead connected, jumper the red lead to frame ground. If the engine goes to high speed, the fault is in the reed switch or associated leads. 3. If the engine does NOT go to high speed (in step 2), the Idler PC board may be faulty.
<p>The engine will NOT go to high speed when a load is applied to the AC auxiliary receptacles. The engine does go to high speed when a load is applied to the welding output terminals.</p>	<ol style="list-style-type: none"> 1. Check the auxiliary power plug and associated leads for loose or faulty connections. 2. The load may be too small. The load must be above 150 watts. 	<ol style="list-style-type: none"> 1. Check the leads associated with the current transformer for loose or faulty connections. See the Wiring Diagram. 2. Check the current transformer for "opens" in the windings. 3. The Idler PC board may be faulty. Replace.

 **CAUTION**

If for any reason you do not understand the test procedures or are unable to perform the test/repairs safely, contact the Lincoln Electric Service Department for electrical troubleshooting assistance before you proceed. Call 216-383-2531 or 1-888-935-3877.

Classic III and IIID



Return to Section TOC

Return to Section TOC

Return to Section TOC

Return to Section TOC

Return to Master TOC

Return to Master TOC

Return to Master TOC

Return to Master TOC

TROUBLESHOOTING & REPAIR

Observe Safety Guidelines detailed in the beginning of this manual.

TROUBLESHOOTING GUIDE

PROBLEMS (SYMPTOMS)	POSSIBLE AREAS OF MISADJUSTMENT(S)	RECOMMENDED COURSE OF ACTION
FUNCTION PROBLEMS		
<p>The engine will NOT go to high speed when either a welding load or an auxiliary load is connected to the Classic III. The machine has normal output and engine speed when the Idler switch is in the "High" position.</p>	<ol style="list-style-type: none"> 1. Check the welding cables and auxiliary load leads for loose or faulty connections. 2. Check for mechanical restrictions or missing parts in the idler and throttle linkage (springs, etc.). 	<ol style="list-style-type: none"> 1. The Idler PC board may be faulty. Replace.
<p>The engine will not shut down.</p>	<ol style="list-style-type: none"> 1. Make sure the ignition switch is turned off and operating correctly. 	<ol style="list-style-type: none"> 1. The Classic III gasoline model ignition switch supplies 12VDC to both the ignition coil and the fuel shut-off solenoid. Check that these circuits are operating correctly. See the Wiring Diagram. When the ignition switch is in the "off" position, there should NOT be 12VDC applied to the ignition coil nor the fuel shut-off solenoid. 2. The Classic IIID diesel model ignition switch supplies 12VDC to the pump solenoid and the fuel lift pump. Check that these circuits are operating correctly. See the Wiring Diagram. When the ignition switch is in the "off" position, there should NOT be 12 VDC applied to the pump solenoid nor the fuel lift pump.

 **CAUTION**

If for any reason you do not understand the test procedures or are unable to perform the test/repairs safely, contact the Lincoln Electric Service Department for electrical troubleshooting assistance before you proceed. Call 216-383-2531 or 1-888-935-3877.

Classic III and IIID



Return to Section TOC
Return to Master TOC

TROUBLESHOOTING & REPAIR

TROUBLESHOOTING GUIDE

Observe Safety Guidelines detailed in the beginning of this manual.

PROBLEMS (SYMPTOMS)	POSSIBLE AREAS OF MISADJUSTMENT(S)	RECOMMENDED COURSE OF ACTION
ENGINE PROBLEMS		
<p>The engine "cranks" but will not start (Classic III gasoline models only).</p>	<ol style="list-style-type: none"> 1. Check for adequate fuel supply. 2. Make sure the ignition switch is in the "ON" position. 	<ol style="list-style-type: none"> 1. Check the ignition switch for proper operation. Check the associated leads for loose or faulty connections. See the Wiring Diagram. 2. Check the fuel shut-off solenoid. Make sure it is opening when 12VDC is applied to it. See the Wiring Diagram. 3. The engine ignition system or engine may be in need of service.
<p>The engine "cranks" but will not start (Classic IIID diesel models only).</p>	<ol style="list-style-type: none"> 1. Check for adequate fuel supply. 2. Make sure the ignition switch is in the "ON" position. 3. Press the glow plug button for 10 to 20 seconds. 4. Make sure the engine protection "Reset" button is pressed. 5. Check the fuse in the engine protection relay. See the Wiring Diagram. 6. If the fuel supply is cut off or runs out while the fuel pump is operating, air may be entrapped in the fuel distribution system. If this happens, bleeding of the fuel system may be necessary. See the Engine Operating Manual. 	<ol style="list-style-type: none"> 1. Check the ignition switch for proper operation. Check the associated leads for loose or faulty connections. See the Wiring Diagram. 2. Check the pump solenoid and fuel lift pump. Make sure they are operating when 12VDC is applied to them. See the Wiring Diagram. 3. The engine protection relay may be faulty. Replace. 4. The engine fuel injectors may need service.

CAUTION

If for any reason you do not understand the test procedures or are unable to perform the test/repairs safely, contact the Lincoln Electric Service Department for electrical troubleshooting assistance before you proceed. Call 216-383-2531 or 1-888-935-3877.

 Classic III and IIID



Return to Section TOC
Return to Master TOC

TROUBLESHOOTING & REPAIR

TROUBLESHOOTING GUIDE

Observe Safety Guidelines detailed in the beginning of this manual.

PROBLEMS (SYMPTOMS)	POSSIBLE AREAS OF MISADJUSTMENT(S)	RECOMMENDED COURSE OF ACTION
ENGINE PROBLEMS		
<p>The engine starts but shuts down after a short period of time.</p>	<ol style="list-style-type: none"> 1. Check for adequate fuel supply. 2. Check the engine oil level. 3. Check the coolant. 	<ol style="list-style-type: none"> 1. The Classic IID diesel only: The oil pressure switch or temperature sensor may be causing the engine protection relay to shut off the fuel supply to the engine. 2. The protection relay may be faulty. 3. The engine fuel injectors may need service.

 **CAUTION**

If for any reason you do not understand the test procedures or are unable to perform the test/repairs safely, contact the Lincoln Electric Service Department for electrical troubleshooting assistance before you proceed. Call 216-383-2531 or 1-888-935-3877.

Classic III and IID



Return to Section TOC

Return to Section TOC

Return to Section TOC

Return to Section TOC

Return to Master TOC

Return to Master TOC

Return to Master TOC

Return to Master TOC

TROUBLESHOOTING & REPAIR

TROUBLESHOOTING GUIDE

Observe Safety Guidelines detailed in the beginning of this manual.

PROBLEMS (SYMPTOMS)	POSSIBLE AREAS OF MISADJUSTMENT(S)	RECOMMENDED COURSE OF ACTION
WELDING PROBLEMS		
The welding arc is loud and spatters excessively.	<ol style="list-style-type: none"> 1. The current setting may be too high for the electrode and process. 2. The polarity may be wrong for the electrode and process. 	<ol style="list-style-type: none"> 1. Check the engine speed. High idle speed should be 1800 RPM. 2. Check the DC generator brushes for good commutation and alignment. Contact the Lincoln Electric Service Dept. 1-216-383-2531 or 1-888-935-3877.
The welding arc frequently "pops out."	<ol style="list-style-type: none"> 1. The Fine Current Control rheostat may be set too low for the electrode and process. 2. Check the welding cables for loose or faulty connections. 	<ol style="list-style-type: none"> 1. Check the engine speed. High idle speed should be 1800 RPM. See Engine Throttle Adjustment. 2. The Current Range Selector switch may be faulty. Check for proper operation. 3. Check the DC generator brushes for good commutation and alignment. Contact the Lincoln Electric Service Dept. 1-216-383-2531 or 1-888-935-3877.

 **CAUTION**

If for any reason you do not understand the test procedures or are unable to perform the test/repairs safely, contact the Lincoln Electric Service Department for electrical troubleshooting assistance before you proceed. Call 216-383-2531 or 1-888-935-3877.

Classic III and IIID



Return to Section TOC
Return to Master TOC

TROUBLESHOOTING & REPAIR

ALTERNATOR ROTOR TEST

WARNING

Service and repair should be performed by only Lincoln Electric factory trained personnel. Unauthorized repairs performed on this equipment may result in danger to the technician or machine operator and will invalidate your factory warranty. For your safety and to avoid electrical shock, please observe all safety notes and precautions detailed throughout this manual.

If for any reason you do not understand the test procedures or are unable to perform the test/repairs safely, contact the Lincoln Electric Service Department for electrical troubleshooting assistance before you proceed. Call 216-383-2531 or 1-888-935-3877.

TEST DESCRIPTION

This test will help determine if there is a shorted, open or grounded winding in the alternator rotor.

MATERIALS NEEDED

- Volt/Ohmmeter
- 3/8" nut driver or socket wrench
- Wiring Diagram
- 5/16" nut driver or socket wrench

Classic III and IIID



ALTERNATOR ROTOR TEST *(continued)*

FIGURE F.1 – ALTERNATOR COVER REMOVAL

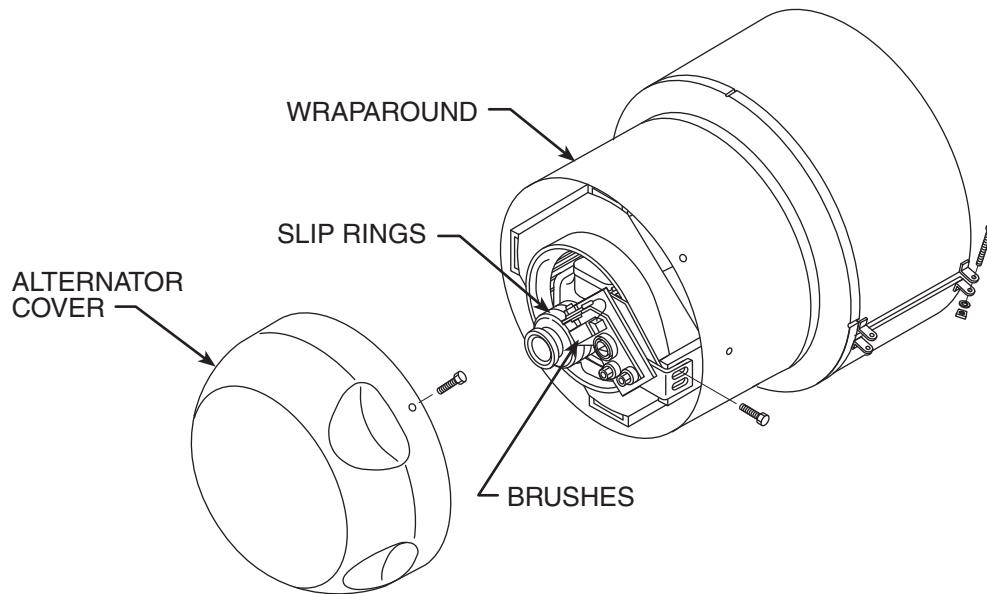

TEST PROCEDURE

1. Turn engine off.
2. With the 3/8" nut driver or socket wrench, loosen the screws on the left and right sides and bottom of the alternator wrap-around. See Figure F.1.
3. With the 5/16" socket wrench, remove the four screws from the alternator cover. See Figure F.1.
4. Remove the alternator cover and wrap-around. Be careful to clear the leads.
5. Locate and lift the brushes off of the rotor slip rings. See Figure F.1.

ALTERNATOR ROTOR TEST *(continued)*

6. Working from the left side of the machine, measure the resistance across the rotor slip rings.
 - a. Set the ohmmeter on the low scale (X1).
 - b. Place one meter probe on one of the rotor slip rings. Place the other probe on the other slip ring. See Figure F.2.
 - c. Check the resistance across the slip rings. It should read approximately 41 ohms.

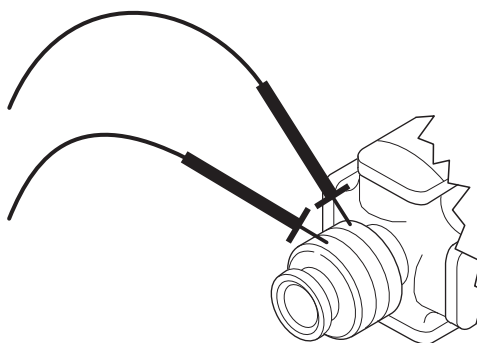
FIGURE F.2 – MEASURING ROTOR RESISTANCE

Classic III and IIID



ALTERNATOR ROTOR TEST (*continued*)

7. Measure the rotor resistance to ground.
 - a. Set the ohmmeter on the high scale (X100,000).
 - b. Place one probe on either of the rotor slip rings. Place the other probe on any good, unpainted ground. See Figure F.3.
 - c. Check the resistance. It should read very high, at least 0.5 megohm (500,000 ohms).
8. Replace the brushes on the slip rings. Make sure they are seated correctly.
9. Reinstall the alternator cover and wrap-around.

If the test does not meet the resistance specifications, then the rotor may be faulty. Replace the rotor.

FIGURE F.3 – MEASURING ROTOR RESISTANCE TO GROUND

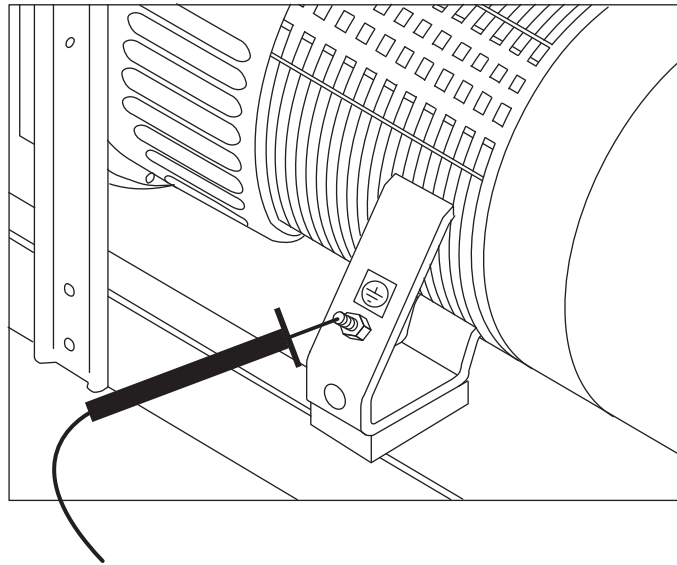

TROUBLESHOOTING & REPAIR

FIELD SHUNT WINDING TEST

WARNING

Service and repair should be performed by only Lincoln Electric factory trained personnel. Unauthorized repairs performed on this equipment may result in danger to the technician or machine operator and will invalidate your factory warranty. For your safety and to avoid electrical shock, please observe all safety notes and precautions detailed throughout this manual.

If for any reason you do not understand the test procedures or are unable to perform the test/repairs safely, contact the Lincoln Electric Service Department for electrical troubleshooting assistance before you proceed. Call 216-383-2531 or 1-888-935-3877.

TEST DESCRIPTION

This test will help determine if the field shunt coils are shorted, open or grounded.

MATERIALS NEEDED

Volt/Ohmmeter
Wiring Diagram

Classic III and IIID



FIELD SHUNT WINDING TEST *(continued)*

FIGURE F.4 – PLUG P10 LOCATIONS

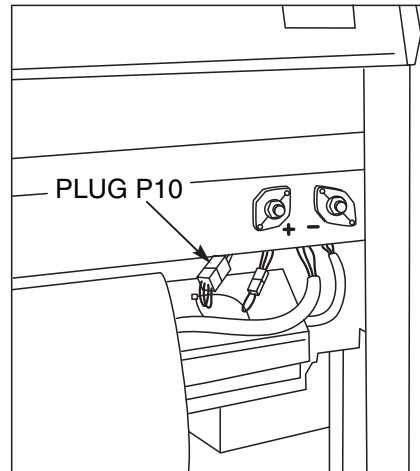
**TEST PROCEDURE**

1. Turn engine off.
2. Unlatch, lift and secure the left side door. Note that there are latches at both ends of the door.
3. Locate and remove plug P10. See Figure F.4.
4. Locate the blue lead (U, pin 3) and the brown lead (N, pin 5) in the harness plug. See **Figure F.5**.

FIELD SHUNT WINDING TEST (*continued*)

FIGURE F.5 – SHUNT LEAD RESISTANCE CHECK

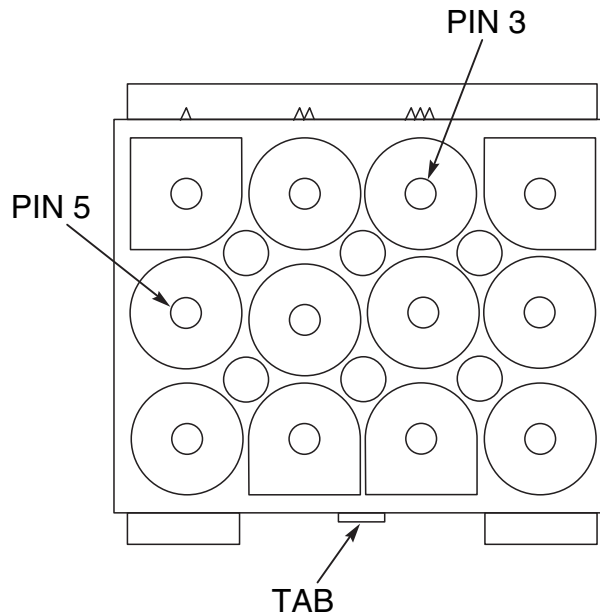

5. Using the volt/ohmmeter set on the low scale (X1), measure the resistance between the blue and the brown leads. See Figure F.5. Normal resistance is approximately 50 ohms.
6. Also measure the resistance from either lead (blue or brown) to ground. Set the volt/ohmmeter on the high scale (X100,000). This resistance should be at least 500,000 ohms.
7. If the test does not meet the resistance specifications, then check the harness plug and inline connectors for loose connections or shorted leads.
8. If the plug and associated leads are okay, then the shunt field coils may be faulty. Replace.
9. If the test does meet the resistance specifications, then the shunt coils are okay.
10. Replace plug P10, making sure the leads and plug are secure.
11. Close and latch the left side door.

FLASHING THE FIELDS



WARNING

Service and repair should be performed by only Lincoln Electric factory trained personnel. Unauthorized repairs performed on this equipment may result in danger to the technician or machine operator and will invalidate your factory warranty. For your safety and to avoid electrical shock, please observe all safety notes and precautions detailed throughout this manual.

If for any reason you do not understand the test procedures or are unable to perform the test/repairs safely, contact the Lincoln Electric Service Department for electrical troubleshooting assistance before you proceed. Call 216-383-2531 or 1-888-935-3877.

DESCRIPTION

This procedure will "flash"
the fields of an exciter that has lost excitation.

MATERIALS NEEDED

- 12-volt automotive battery
- Two jumper wires with alligator clip on each end
- Wiring Diagram

Classic III and IIID



TROUBLESHOOTING & REPAIR

FLASHING THE FIELDS *(continued)*

FIGURE F.6 - FLASHING THE FIELDS

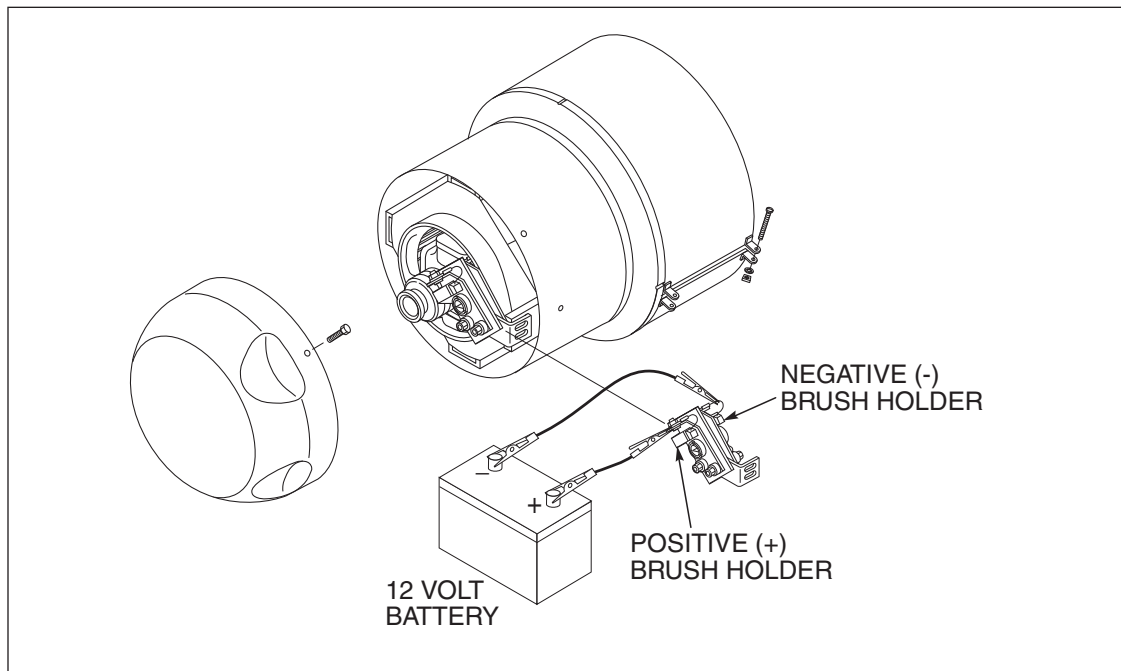

PROCEDURE

1. Turn engine OFF.
2. Remove the cover from the exciter. See Figure F.6.
3. Turn the FINE CURRENT ADJUSTMENT control (rheostat) to "100."
4. Using one of the leads with alligator clips, connect the negative terminal of the 12-volt automotive battery to the negative brushholder. This is the brushholder nearest the rotor lamination. See Figure F.6 and the Wiring Diagram.
5. With the engine OFF, use the other lead with alligator clips and touch the positive battery terminal to the positive brushholder. Then disconnect the leads to remove the battery from the circuit.
6. Replace the exciter cover.
7. Start the welder. The generator voltage should build up.

DO NOT remove brush holder.

If voltage does not build up, there are a number of possible causes, such as loose or missing brushes, open leads or poor connections at the field diode bridge or between the exciter alternator brushes and the generator brushes. See OUTPUT PROBLEMS in the *Troubleshooting Guide* located in this section of the manual for recommended action.

Classic III and IIID



TROUBLESHOOTING & REPAIR

IDLER SOLENOID TEST

WARNING

Service and repair should be performed by only Lincoln Electric factory trained personnel. Unauthorized repairs performed on this equipment may result in danger to the technician or machine operator and will invalidate your factory warranty. For your safety and to avoid electrical shock, please observe all safety notes and precautions detailed throughout this manual.

If for any reason you do not understand the test procedures or are unable to perform the test/repairs safely, contact the Lincoln Electric Service Department for electrical troubleshooting assistance before you proceed. Call 216-383-2531 or 1-888-935-3877.

TEST DESCRIPTION

This test will determine if the idler solenoid is capable of functioning when it is energized with 12VDC.

MATERIALS NEEDED

- External 12VDC supply
- Wiring Diagram
- 5/16" nut driver
- 5/16" wrench

Classic III and IIID



TROUBLESHOOTING & REPAIR

IDLER SOLENOID TEST (*continued*)

FIGURE F.7 - SOLENOID LEAD CONNECTIONS

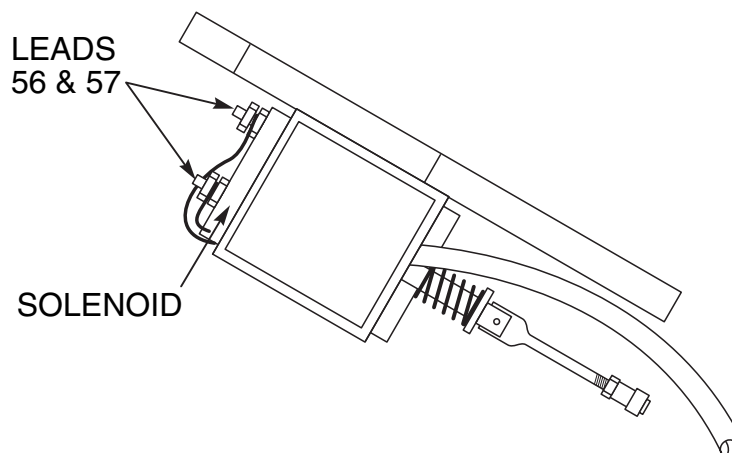

TEST PROCEDURE

1. Turn engine off.
2. Unlatch, lift and secure the left side door. Note that there are latches at both ends of the door.
3. Using the 5/16" nut driver, remove the two washers, nuts, and screws holding the fan guard. If necessary, remove the fan guard (Classic IIID only).
4. Locate leads #56 and #57 on the idler solenoid. See Figure F.7 and the Wiring Diagram. Using the 5/16" wrench, remove the leads from the solenoid.
5. Using the external voltage supply, apply 12VDC to the idler solenoid terminals. Attach positive (+) to the terminal where lead #56 was connected. The solenoid should activate.
6. The solenoid should deactivate when the 12VDC is removed.
7. If the solenoid does not operate properly, check for a mechanical restriction in the linkage or a missing spring.
8. If the linkage is intact and the solenoid does not operate correctly when 12VDC is applied, the solenoid may be faulty. Replace. Normal solenoid coil resistance is approximately 9 ohms.
9. When the test is complete and the problem repaired, be sure to reconnect leads #56 and #57 to the idler solenoid.
10. Replace the fan guard if removed earlier (Classic IIID only).
11. Close and latch the left side door.

Classic III and IIID



TROUBLESHOOTING & REPAIR

ENGINE THROTTLE ADJUSTMENT TEST - CLASSIC IIID (DIESEL)



WARNING

Service and repair should be performed by only Lincoln Electric factory trained personnel. Unauthorized repairs performed on this equipment may result in danger to the technician or machine operator and will invalidate your factory warranty. For your safety and to avoid electrical shock, please observe all safety notes and precautions detailed throughout this manual.

If for any reason you do not understand the test procedures or are unable to perform the test/repairs safely, contact the Lincoln Electric Service Department for electrical troubleshooting assistance before you proceed. Call 216-383-2531 or 1-888-935-3877.

TEST DESCRIPTION

If the machine output is low, or high, this test will determine whether the engine is operating at the correct speed (RPM) during both HIGH and LOW idle conditions. Directions for adjusting the throttle to the correct RPM are given.

MATERIALS NEEDED

Slot head screw driver

7/16" wrench

5/16" wrench

White or red marking pencil, strobe-tach, frequency counter, or oscilloscope

Classic III and IIID



ENGINE THROTTLE ADJUSTMENT TEST *(continued)*

FIGURE F.8 - STROBE MARK LOCATION

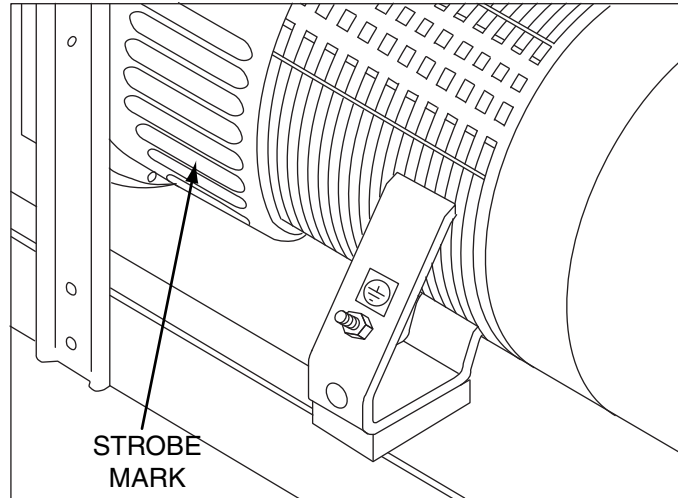

TEST PROCEDURE

Strobe Tach Method

1. Turn the engine welder OFF.
2. Unlatch, lift and secure the left side door. Note that there are latches at both ends of the door.
3. With a white or red marking pencil, place a mark on one of the blower paddles. See Figure F.8 for location.
4. Connect the strobe-tach according to the manufacturer's instructions.
5. Start the engine and direct the strobe-tach light on the blower paddle. Synchronize it to the rotating mark.

With the machine at HIGH IDLE the tach should read between 1780 and 1810 RPM.

With the machine at LOW IDLE the tach should read between 1325 and 1475 RPM.

TROUBLESHOOTING & REPAIR

ENGINE THROTTLE ADJUSTMENT TEST (*continued*)

6. If either of the readings is incorrect, adjust the throttle as follows:

Adjust HIGH IDLE: Use the 5/16" wrench to loosen the locking nut. See **Figure F.9** for location of the adjusting screw and locking nut. Turn the threaded screw counter-clockwise to increase the HIGH IDLE speed. Adjust the speed until the tach reads between 1780 and 1810 RPM. Retighten the locking nut.

Adjust LOW IDLE: First make sure there is no load on the machine. Set the IDLE switch to AUTO and wait for the engine to change to low idle speed.

Use the 7/16" wrench to loosen the solenoid lever arm locking nut. See **Figure F.10**. Adjust the threaded solenoid lever arm shaft, to change the amount of throw in the lever arm, until the tach reads between 1325 and 1475 RPM. Retighten the locking nut.

Frequency Counter Method

1. Plug the frequency counter into one of the 115 VAC auxiliary receptacles.
2. Start the engine and check the frequency counter. At HIGH IDLE (1800 RPM), the counter should read 60 Hz. At LOW IDLE (1400 RPM), the counter should read 47 Hz. Note that these are median measurements; hertz readings may vary slightly above or below.
3. If either of the readings is incorrect, adjust the throttle as follows:

Adjust HIGH IDLE: Use the 5/16" wrench to loosen the locking nut. See **Figure F.9** for location of the adjusting screw and locking nut. Turn the threaded screw counter-clockwise to increase the HIGH IDLE speed. Adjust the speed until the frequency reads 60 Hz. Retighten the locking nut.

Adjust LOW IDLE: First make sure there is no load on the machine. Set the IDLE switch to AUTO and wait for the engine to change to low idle speed. Use the 7/16" wrench to loosen the solenoid lever arm locking nut. See **Figure F.10**. Adjust the threaded solenoid lever arm shaft, to change the amount of throw in the lever arm, until the frequency reads 47 Hz. Retighten the locking nut.

Oscilloscope Method

1. Connect the oscilloscope to the 115 VAC receptacle, according to the manufacturer's instructions. At HIGH IDLE (1800 RPM), the waveform should exhibit a period of 16.6 milliseconds. At LOW IDLE (1400 RPM), the waveform should exhibit a period of 21.4 milliseconds. Refer to the **NORMAL OPEN CIRCUIT VOLTAGE WAVEFORM (115 VAC SUPPLY) HIGH IDLE - NO LOAD** in this section of the manual.
2. If either of these periods is incorrect, adjust the throttle as follows:

Adjust HIGH IDLE: Use the 5/16" wrench to loosen the locking nut. See **Figure F.9** for location of the adjusting screw and locking nut. Turn the threaded screw counter-clockwise to increase the HIGH IDLE speed. Adjust the speed until the period is 16.6 milliseconds. Retighten the locking nut.

Adjust LOW IDLE: First make sure there is no load on the machine. Set the IDLE switch to AUTO and wait for the engine to change to low idle speed. Use the 7/16" wrench to loosen the solenoid lever arm locking nut. See **Figure F.10**. Adjust the threaded solenoid lever arm shaft, to change the amount of throw in the lever arm, until the period is 21.4 milliseconds. Retighten the locking nut.

TROUBLESHOOTING & REPAIR

ENGINE THROTTLE ADJUSTMENT TEST *(continued)*

FIGURE F.9 - HIGH IDLE ADJUSTMENT

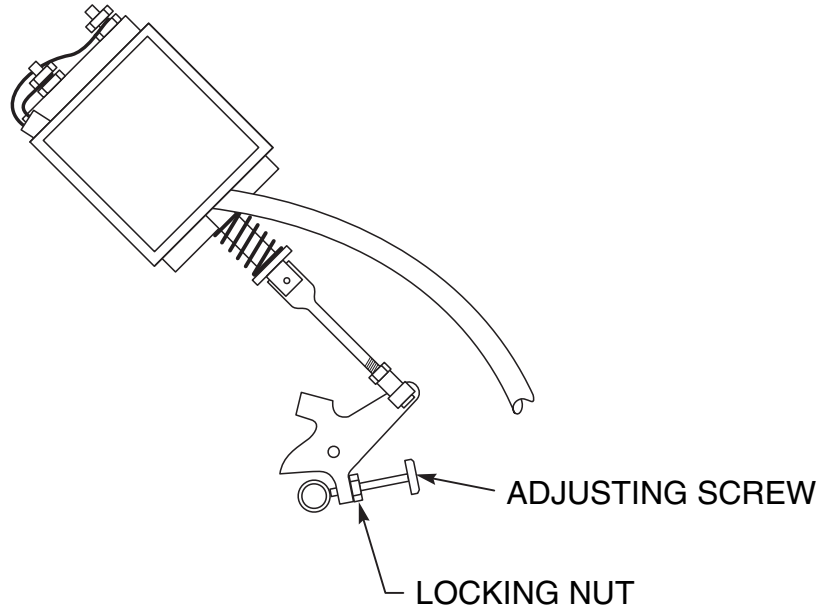
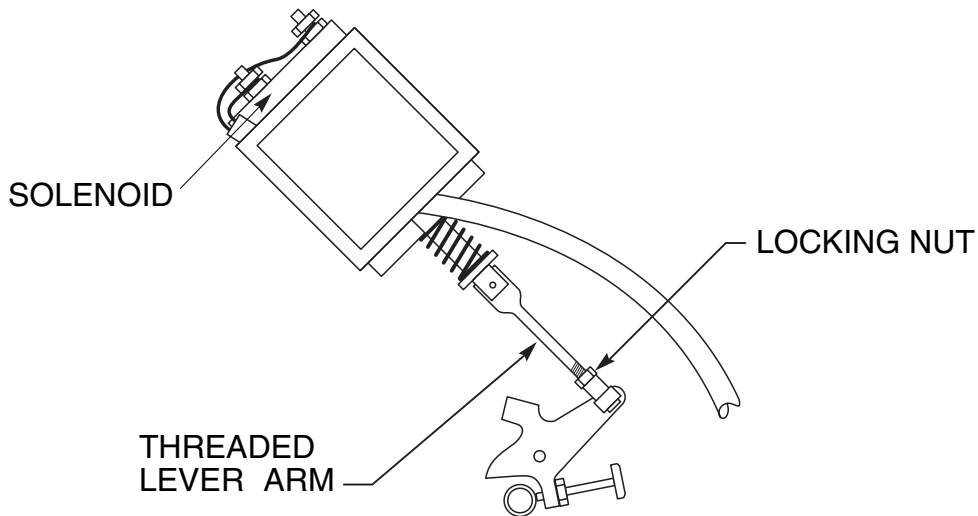

FIGURE F.10 - LOW IDLE ADJUSTMENT



Classic III and IIID



Return to Section TOC

Return to Master TOC

Return to Section TOC

Return to Master TOC

Return to Section TOC

Return to Master TOC

Return to Section TOC

Return to Master TOC

TROUBLESHOOTING & REPAIR

ENGINE THROTTLE ADJUSTMENT TEST - CLASSIC III (GASOLINE)

WARNING

Service and repair should be performed by only Lincoln Electric factory trained personnel. Unauthorized repairs performed on this equipment may result in danger to the technician or machine operator and will invalidate your factory warranty. For your safety and to avoid electrical shock, please observe all safety notes and precautions detailed throughout this manual.

If for any reason you do not understand the test procedures or are unable to perform the test/repairs safely, contact the Lincoln Electric Service Department for electrical troubleshooting assistance before you proceed. Call 216-383-2531 or 1-888-935-3877.

TEST DESCRIPTION

If the machine output is low, or high, this test will determine whether the engine is operating at the correct speed (RPM) during both HIGH and LOW idle conditions. Directions for adjusting the throttle to the correct RPM are given.

MATERIALS NEEDED

White or red marking pencil
7/16" wrench
3/8" wrench

Classic III and IIID



ENGINE THROTTLE ADJUSTMENT TEST *(continued)*

FIGURE F.11 - BLOWER PADDLE MARK LOCATION

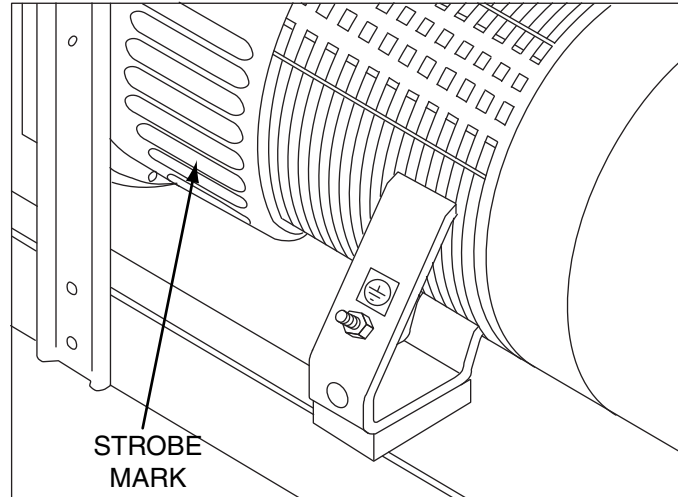

TEST PROCEDURE

STROBE TACH METHOD

1. Conduct this procedure with the engine OFF.
2. Unlatch, lift, and secure the right and left side doors.
3. With the white or red marking pencil, place mark on one of the blower paddles. See Figure F.11.
4. Connect the strobe-tach according to the manufacturer's instructions.
5. Start the engine and direct the strobe-tach light on the blower paddle and synchronize it to the rotating mark.

With the machine at HIGH IDLE, the tach should read between 1780 and 1810 RPM. With the machine at LOW IDLE, the tach should read between 1325 and 1475 RPM.

TROUBLESHOOTING & REPAIR

6. If either of these readings is incorrect, adjust the throttle as follows:

Adjust High Idle

- Make sure there is no load on the machine.
- Set the Idler switch to the HIGH position.
- Locate the governor on the left side of the engine. See **Figure F.12**.
- Using the 3/8" wrench to turn the adjustment screw and locking nut, adjust the high idle speed to between 1780 - 1810 RPM. It may not be necessary to remove the seal. See **Figure F.12**.
- If further adjustments are necessary, consult the Engine Manual.

Adjust Low Idle

- Make sure there is no load on the machine.
- Set the Idler switch to AUTO and wait for the engine to change to low idle speed.
- Check the alignment of the idler rod so that the plunger can move freely.
- Using the 7/16" wrench, loosen the idler rod locking nut. This is located on the idler rod between the carburetor ball joint and the idler solenoid. See **Figure F.13**.
- Rotate the carburetor shaft, and while holding it against the idle stop screw on the carburetor, adjust this screw to obtain low idle RPM (1325 RPM).
- With the idler plunger fully seated, adjust idle speed by rotating the threaded rod in the ball joint. Lock the position by tightening the nut with the ball joint.
- RPM should be 1325-1475 RPM. If necessary, adjust the idle screw to increase the idle speed by a maximum of 50 RPM.

FREQUENCY COUNTER METHOD

- Plug the frequency counter into one of the 115 VAC auxiliary receptacles.
- Start the engine and check the frequency counter. At HIGH IDLE (1800 RPM), the counter should read 60 Hz. At LOW IDLE (1400 RPM), the counter should read 47 Hz. Note that these are median measurements; hertz readings may vary slightly above or below.
- If either of the readings is incorrect, adjust the throttle as follows.

Adjust High Idle

- Make sure there is no load on the machine.
- Set the Idler switch to the HIGH position.
- Locate the governor on the left side of the engine. See **Figure F.12**.
- Using the 3/8" wrench to turn the adjustment screw and locking nut, adjust the high idle speed to between 1780 - 1810 RPM. It may not be necessary to remove the seal. See **Figure F.12**.
- If further adjustments are necessary, consult the Engine Manual.

Adjust Low Idle

- Make sure there is no load on the machine.
- Set the Idler switch to AUTO and wait for the engine to change to low idle speed.
- Check the alignment of the idler rod so that the plunger can move freely.
- Using the 7/16" wrench, loosen the idler rod locking nut. This is located on the idler rod between the carburetor ball joint and the idler solenoid. See **Figure F.13**.
- Rotate the carburetor shaft, and while holding it against the idle stop screw on the carburetor, adjust this screw to obtain low idle RPM (1325 RPM).
- With the idler plunger fully seated, adjust idle speed by rotating the threaded rod in the ball joint. Lock the position by tightening the nut with the ball joint.
- RPM should be 1325-1475 RPM. If necessary, adjust the idle screw to increase the idle speed by a maximum of 50 RPM.

Classic III and IIID



TROUBLESHOOTING & REPAIR

OSCILLOSCOPE METHOD

1. Connect the oscilloscope to the 115 VAC receptacle, according to the manufacturer's instructions. At HIGH IDLE (1800 RPM), the waveform should exhibit a period of 16.6 milliseconds. At LOW IDLE (1400 RPM), the waveform should exhibit a period of 21.4 milliseconds. Refer to the **NORMAL OPEN CIRCUIT VOLTAGE WAVEFORM (115 VAC SUPPLY) HIGH IDLE - NO LOAD** in this section of the manual.
2. If either if the periods is incorrect, adjust the throttle as follows.

Adjust High Idle

- a. Make sure there is no load on the machine.
- b. Set the Idler switch to the HIGH position.
- c. Locate the governor on the left side of the engine. See **Figure F.12**.
- d. Using the 3/8" wrench to turn the adjustment screw and locking nut, adjust the high idle speed to between 1780 - 1810 RPM. It may not be necessary to remove the seal. See **Figure F.12**.
- e. If further adjustments are necessary, consult the Engine Manual.

Adjust Low Idle

- a. Make sure there is no load on the machine.
- b. Set the Idler switch to AUTO and wait for the engine to change to low idle speed.
- c. Check the alignment of the idler rod so that the plunger can move freely.
- d. Using the 7/16" wrench, loosen the idler rod locking nut. This is located on the idler rod between the carburetor ball joint and the idler solenoid. See **Figure F.13**.
- e. Rotate the carburetor shaft, and while holding it against the idle stop screw on the carburetor, adjust this screw to obtain low idle RPM (1325 RPM).
- f. With the idler plunger fully seated, adjust idle speed by rotating the threaded rod in the ball joint. Lock the position by tightening the nut with the ball joint.
- g. RPM should be 1325-1475 RPM. If necessary, adjust the idle screw to increase the idle speed by a maximum of 50 RPM.

FIGURE F.12 - HIGH IDLE ADJUSTMENT

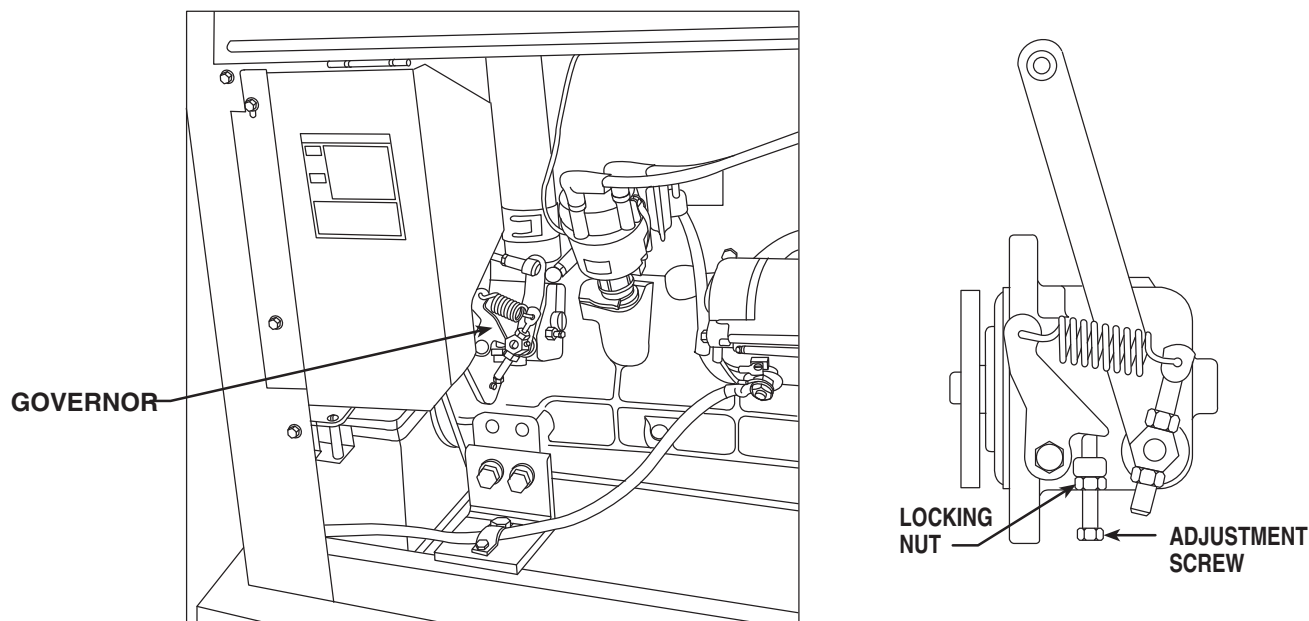

Classic III and IIID



TROUBLESHOOTING & REPAIR

ENGINE THROTTLE ADJUSTMENT TEST (continued)

FIGURE F.13 - LOW IDLE ADJUSTMENT

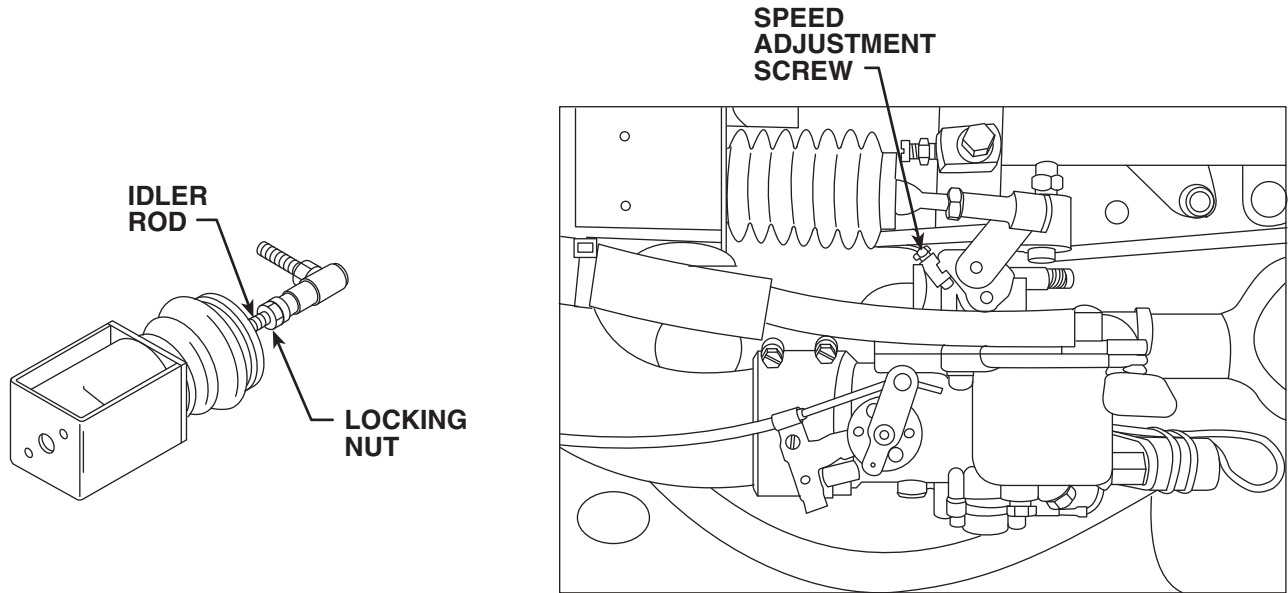

Return to Section TOC

Return to Section TOC

Return to Section TOC

Return to Section TOC

Return to Master TOC

Return to Master TOC

Return to Master TOC

Return to Master TOC

TROUBLESHOOTING & REPAIR

NORMAL OPEN CIRCUIT VOLTAGE WAVEFORM (115VAC SUPPLY) HIGH IDLE – NO LOAD – FINE CURRENT CONTROL RHEOSTAT AT MAXIMUM

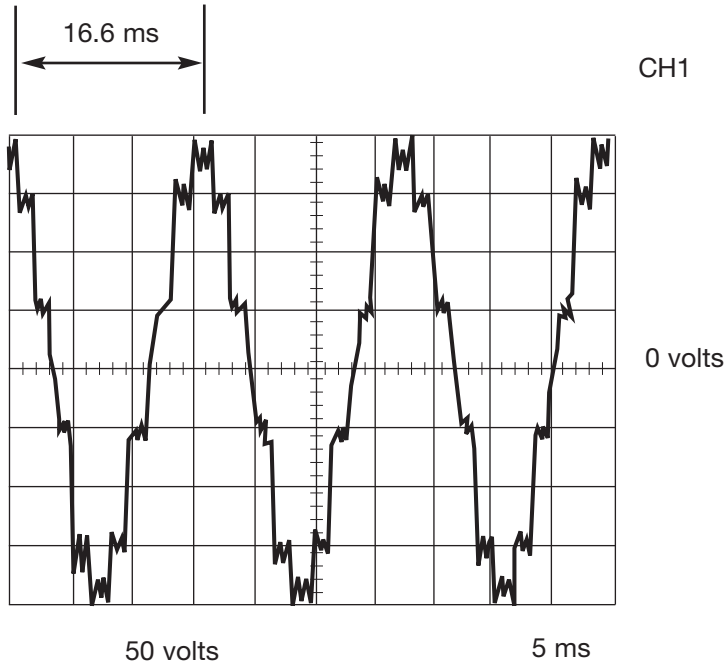

This is the typical auxiliary output voltage generated from a properly operating machine. Note that each vertical division represents 50 volts and that each horizontal division represents 5 milliseconds in time.

Note: Scope probes connected at machine 115VAC receptacle.

SCOPE SETTINGS

Volts/Div.....	50V/Div.
Horizontal Sweep.....	5 ms/Div.
Coupling	DC
Trigger	Internal

Classic III and IIID



Return to Section TOC

Return to Section TOC

Return to Section TOC

Return to Section TOC

Return to Master TOC

Return to Master TOC

Return to Master TOC

Return to Master TOC

TROUBLESHOOTING & REPAIR

NORMAL OPEN CIRCUIT DC WELD VOLTAGE WAVEFORM HIGH IDLE – NO LOAD – FINE CURRENT CONTROL RHEOSTAT AND SELECTOR SWITCH AT MAXIMUM

Return to Section TOC

Return to Section TOC

Return to Section TOC

Return to Section TOC

Return to Master TOC

Return to Master TOC

Return to Master TOC

Return to Master TOC

CH1

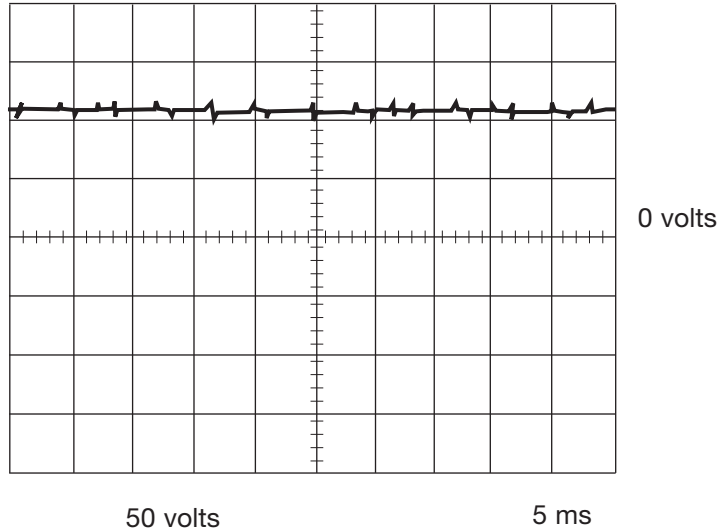

This is the typical DC output voltage generated from a properly operating machine. Note that each vertical division represents 50 volts and that each horizontal division represents 5 milliseconds in time.

Note: Scope probes connected at machine output terminals.

SCOPE SETTINGS

Volts/Div.....	50V/Div.
Horizontal Sweep.....	5 ms/Div.
Coupling	DC
Trigger	Internal

Classic III and IIID



TROUBLESHOOTING & REPAIR

TYPICAL DC WELD OUTPUT VOLTAGE WAVEFORM MACHINE LOADED – SELECTOR SWITCH AT MAXIMUM POSITION

Return to Section TOC

Return to Section TOC

Return to Section TOC

Return to Section TOC

Return to Master TOC

Return to Master TOC

Return to Master TOC

Return to Master TOC

CH1

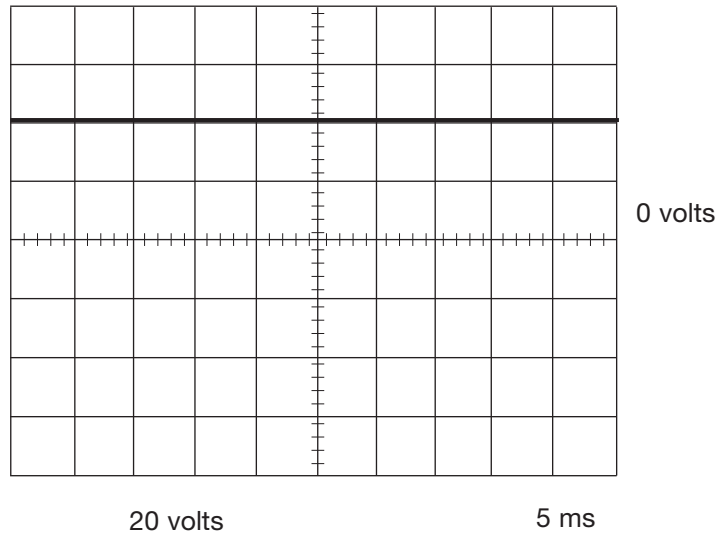

MACHINE LOADED TO 250 AMPS AT 40 VDC

This is the typical DC output voltage generated from a properly operating machine. Note that each vertical division represents 20 volts and that each horizontal division represents 5 milliseconds in time. The machine was loaded with a resistance grid bank.

Note: Scope probes connected at machine output terminals.

SCOPE SETTINGS

Volts/Div	20V/Div.
Horizontal Sweep.....	5 ms/Div.
Coupling	DC
Trigger	Internal

Classic III and IIID



TROUBLESHOOTING & REPAIR

ALTERNATOR ROTOR REMOVAL AND REPLACEMENT



WARNING

Service and repair should be performed by only Lincoln Electric factory trained personnel. Unauthorized repairs performed on this equipment may result in danger to the technician or machine operator and will invalidate your factory warranty. For your safety and to avoid electrical shock, please observe all safety notes and precautions detailed throughout this manual.

If for any reason you do not understand the test procedures or are unable to perform the test/repairs safely, contact the Lincoln Electric Service Department for electrical troubleshooting assistance before you proceed. Call 216-383-2531 or 1-888-935-3877.

DESCRIPTION

This procedure will aid the technician in the removal and replacement of the alternator rotor.

MATERIALS NEEDED

- 3/8" wrench
- 1/2" wrench
- 1-5/8" wrench
- Large slot head screwdriver
- Small gear puller
- 5/16" nut driver

Classic III and IIID



TROUBLESHOOTING & REPAIR

ALTERNATOR ROTOR REMOVAL AND REPLACEMENT *(continued)*

PROCEDURE

1. Turn the engine off.
2. Using the 7/16" wrench, remove the two bolts and washers and partially slide out the battery mounting panel. See Figure F.14
3. With the 1/2" wrench, disconnect the negative battery cable.

FIGURE F.14 – BATTERY PANEL REMOVAL

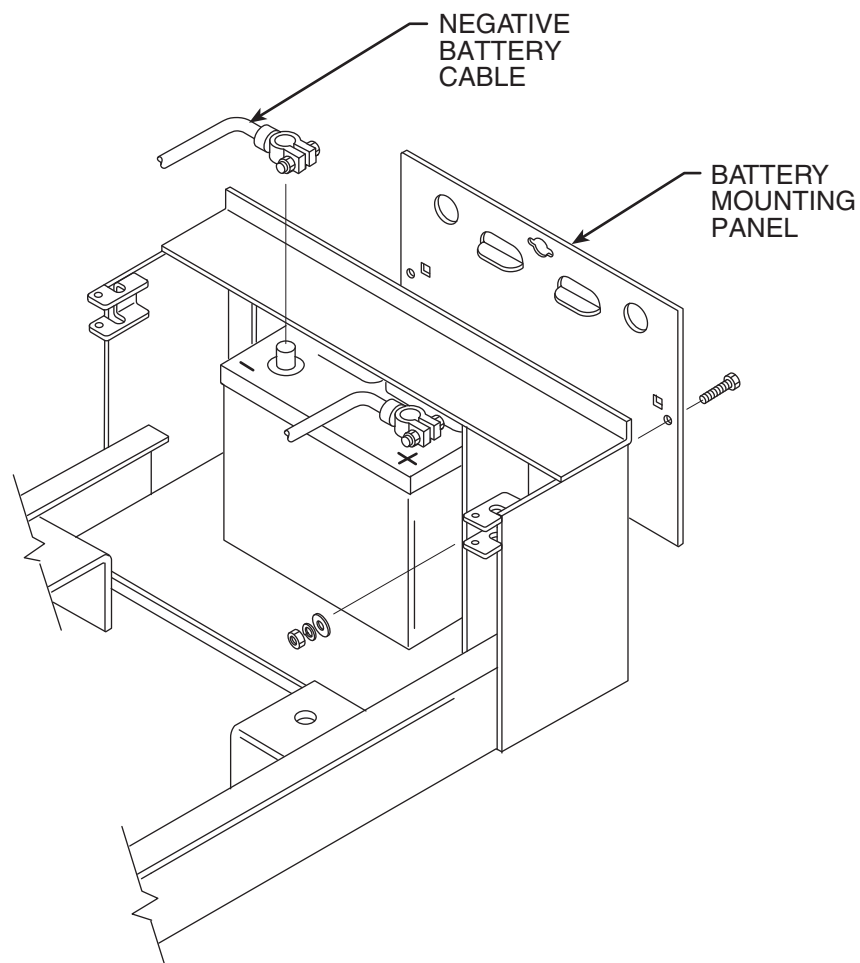

Classic III and IIID



TROUBLESHOOTING & REPAIR

ALTERNATOR ROTOR REMOVAL AND REPLACEMENT (*continued*)

See Figure F.15 for steps 3 - 5.

3. With the 3/8" wrench, loosen the screws on the left and right sides and bottom of the alternator wrap-around.
4. With the 5/16" wrench, remove the 4 screws from the alternator cover.
5. Remove the alternator cover and wrap-around. Be careful to clear the leads.

FIGURE F.15 – ALTERNATOR COVER AND WRAPAROUND REMOVAL

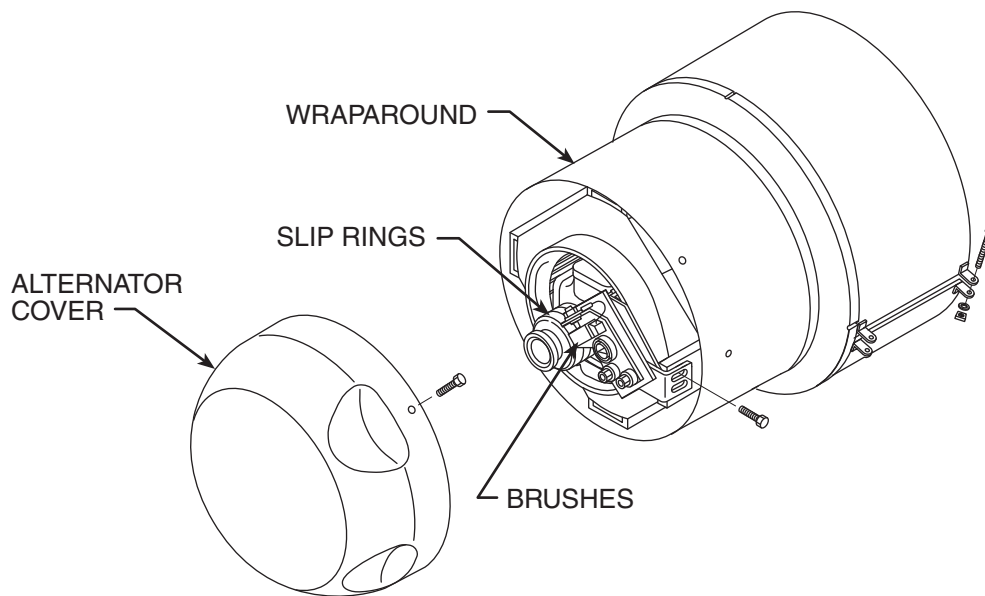

Classic III and IIID



TROUBLESHOOTING & REPAIR

ALTERNATOR ROTOR REMOVAL AND REPLACEMENT (*continued*)

See Figure F.16 for steps 6 - 8.

6. With the 7/16" wrench, remove the two bolts, nuts and washers mounting the brush holder assembly to the stator frame.
7. Bend the flat washer away from the rotor locking nut.

8. With the 1-5/8" socket wrench, remove the rotor locking nut, washer and sleeve collar.

NOTE: The sleeve collar will have to be removed with a gear puller. Be careful not to damage the rotor slip ring assembly. Remove the rotor by pulling it free of the generator shaft.

FIGURE F.16 – ROTOR REMOVAL

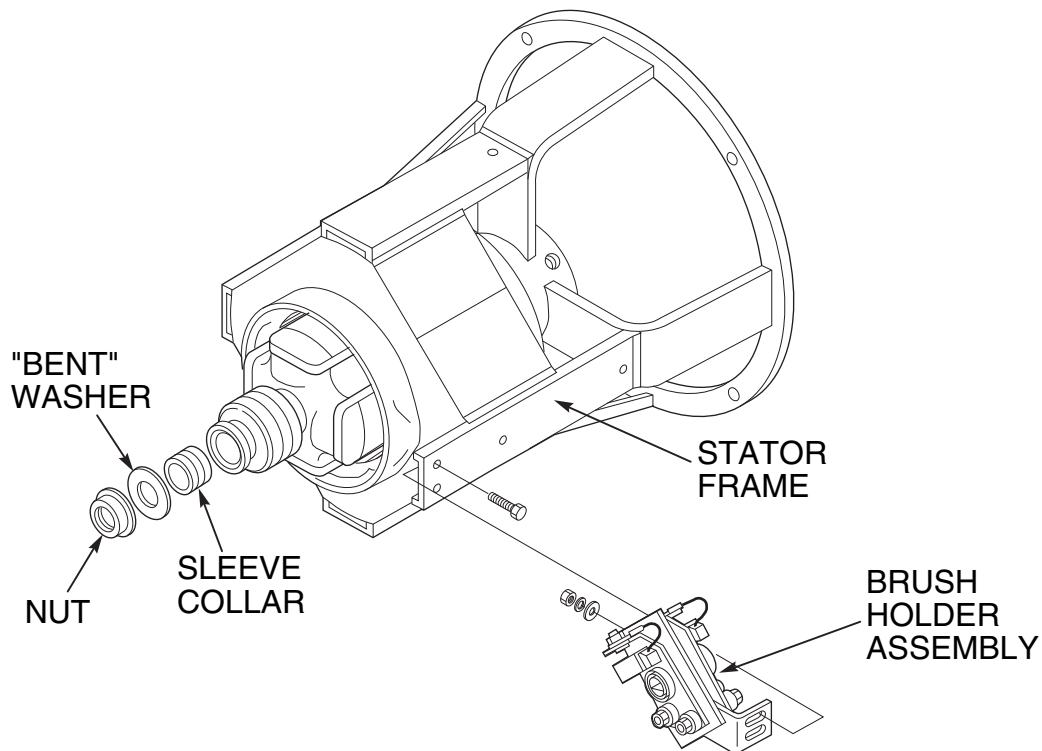

Classic III and IIID



TROUBLESHOOTING & REPAIR

ALTERNATOR ROTOR REMOVAL AND REPLACEMENT (*continued*)

Replacement

9. Carefully mount the rotor onto the generator shaft. Install a new sleeve collar (part number T14337), washer, and rotor locking nut.

NOTE: Be careful not to damage or deform the new sleeve collar. Carefully tap the new sleeve collar into position. The rotor locking nut should be torqued to 175 ft.-lbs.

After the rotor locking nut is properly torqued, bend the washer down over the locking nut.

Check rotor air gap. .017" minimum is allowed.

10. Mount the brush holder assembly to the stator frame using two bolts, washers, and nuts.

Installing and Seating Exciter Slip Ring Brushes

- a. Make sure the slip rings are clean and free from oil and grease.
- b. Spacing between the brush holder and slip rings must be .050" to .090". Adjust as required.
- c. Before placing the exciter brushes in their holders, twist the brush pigtail at its entrance to the brush until the strands are tightly packed and no part of the pigtail protrudes beyond the brush surface in the pigtail slot. When the brush is placed in the holder, clear the pigtail from the side of the holder to allow free radial movement of the brush.

- d. The exciter brush spring must lie flat on the corner of the brush and not touch either side of the retainer.
 - e. With the brushes in place, insert one end of a minimum 24" long piece of 180 grit sandpaper between the slip rings and brushes (abrasive against brushes). With slight additional finger pressure on top of brushes, pull the paper around the circumference of the rings in the direction of rotation only. Repeat this procedure until the entire face of the brush is contoured to the radius of the slip ring.
 - f. Check the brushes to be certain that there is spring tension holding them firmly against the slip rings.
11. Install the alternator cover and wrap-around.
 12. Connect the negative battery cable.

TROUBLESHOOTING & REPAIR

ALTERNATOR STATOR REMOVAL AND REPLACEMENT

WARNING

Service and repair should be performed by only Lincoln Electric factory trained personnel. Unauthorized repairs performed on this equipment may result in danger to the technician or machine operator and will invalidate your factory warranty. For your safety and to avoid electrical shock, please observe all safety notes and precautions detailed throughout this manual.

If for any reason you do not understand the test procedures or are unable to perform the test/repairs safely, contact the Lincoln Electric Service Department for electrical troubleshooting assistance before you proceed. Call 216-383-2531 or 1-888-935-3877.

DESCRIPTION

This procedure will aid the technician in the removal and replacement of the alternator stator.

MATERIALS NEEDED

- 3/8" nut driver
- 3/8" wrench
- 1/2" wrench
- Slot head screwdriver
- Pry bar
- 5/8" wrench
- 7/16" wrench

Classic III and IIID



TROUBLESHOOTING & REPAIR

ALTERNATOR STATOR REMOVAL AND REPLACEMENT *(continued)*

FIGURE F.17 – COMMUTATOR WRAP-AROUND REMOVAL

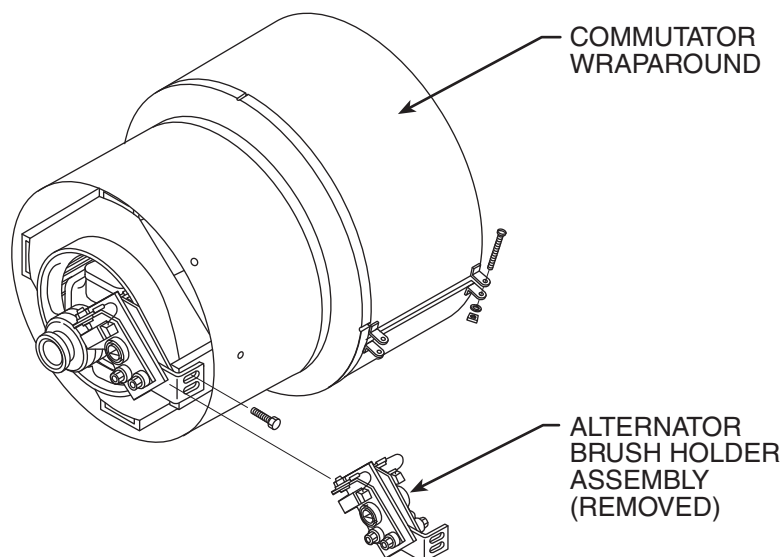

PROCEDURE

1. Turn the engine OFF.
 2. Perform the **Alternator Rotor Removal** procedure.
 3. With the 1/2" wrench, remove the four nuts and bolts holding the case top and doors assembly to the welder frame. Carefully lift up and remove the top and doors assembly.
 4. With the 3/8" nut driver, remove the two leads from the alternator brush holder assembly. Note lead placement. Set brush holder aside.
 5. With the slot head screwdriver, remove the commutator wraparound. See Figure F.17.
 6. Disconnect the yellow and white wires at the in-line connectors. See the Wiring Diagram and **Figure F.18**.
 7. Disconnect the two yellow leads. One is located at the field bridge and the other at the field fuse holder. Cut any necessary cable ties. See **Figure F.18 and F.19**.
 8. Remove the tape and using the 3/8" wrench and slot head screw driver, disconnect the black auxiliary power lead from the current transformer. Cut any necessary cable ties. See the Wiring Diagram and **Figure F.18**.
 9. Remove the red auxiliary power lead from the CB4 circuit breaker. See the Wiring Diagram and **Figure F.19**.
 10. Remove the white auxiliary power lead from the 115VAC receptacle. Cut any necessary cable ties. See **Figure F.19**.
- NOTE:** The CB1 circuit breaker may have to be removed to access the terminal for the white lead.
11. Remove the red lead from the negative terminal of the field rectifier bridge. See **Figure F.19**.
 12. Remove the black lead from the positive terminal of the field rectifier bridge. See **Figure F.19**.

TROUBLESHOOTING & REPAIR

ALTERNATOR STATOR REMOVAL AND REPLACEMENT *(continued)*

FIGURE F.18 - LEAD DISCONNECTION POINTS

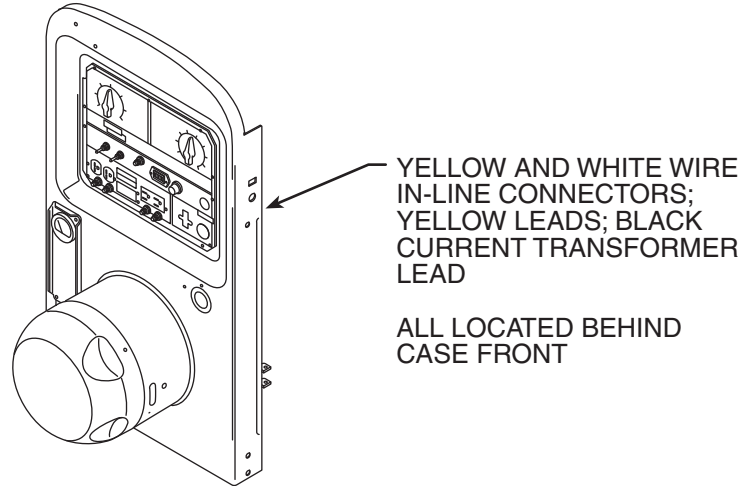
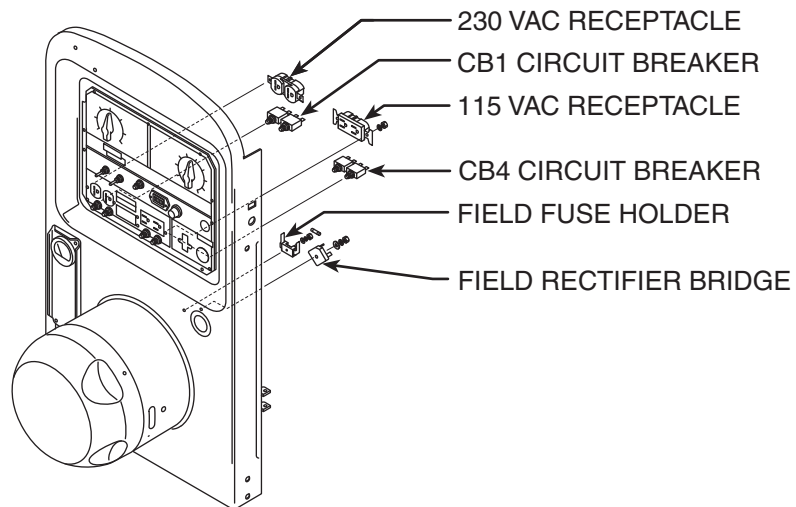

FIGURE F.19- LEAD DISCONNECTION - CIRCUIT BREAKER, RECEPTACLES, FIELD BRIDGE RECTIFIER



Classic III and IIID



Return to Section TOC

Return to Section TOC

Return to Section TOC

Return to Section TOC

Return to Master TOC

Return to Master TOC

Return to Master TOC

Return to Master TOC

TROUBLESHOOTING & REPAIR

ALTERNATOR STATOR REMOVAL AND REPLACEMENT *(continued)*

13. Clear the leads in preparation for removing the stator/end bracket.
14. Lift the eight brushes from the commutator. Note the position of the brushes for reassembly.

FIGURE F.20 - GENERATOR BRUSH HOLDER CABLE REMOVAL

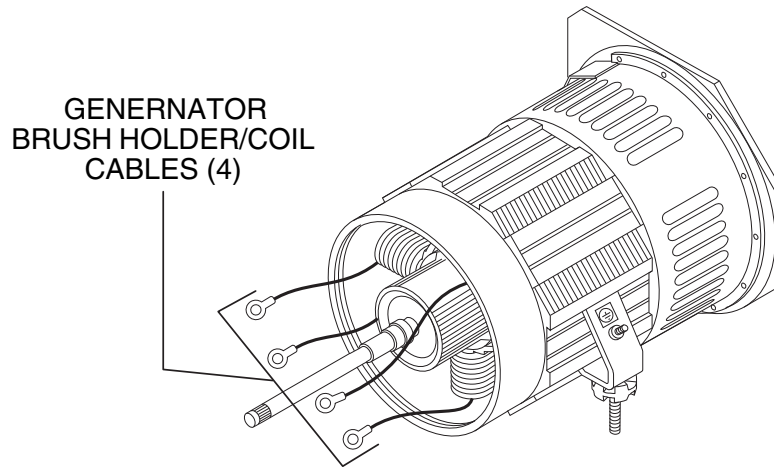

15. With the 1/2" wrench, disconnect and clear the four heavy cables from the generator brush holders to the coils in the generator frame. It is not necessary to remove the brush holder jumper cables. See Figure F.20. Label leads and positions for re-assembly.

TROUBLESHOOTING & REPAIR

ALTERNATOR STATOR REMOVAL AND REPLACEMENT *(continued)*

FIGURE F.21 - DRILL SPOT LOCATIONS

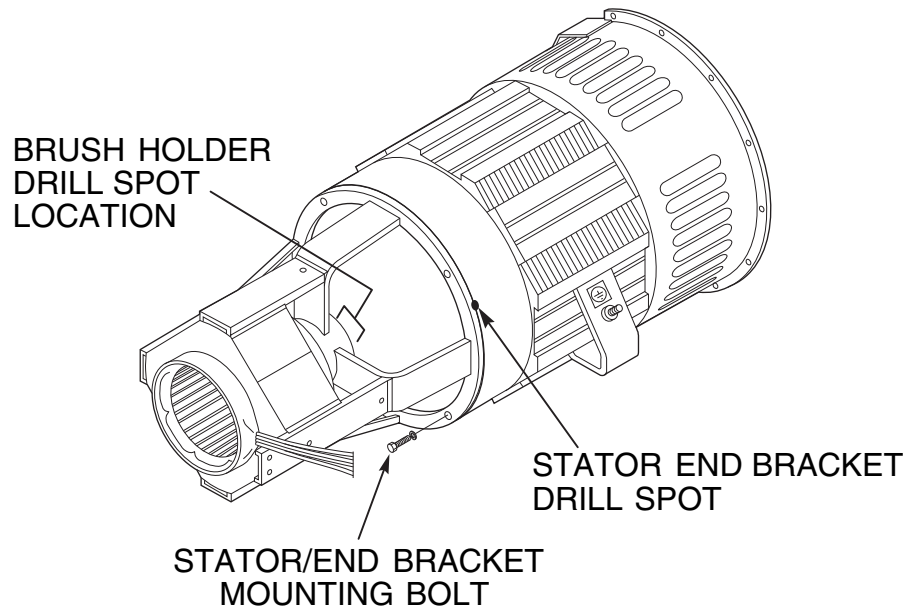

16. With the 5/8" wrench, remove the four bolts mounting the stator/end bracket assembly to the generator frame. Note the "drill spot" for reassembly. See Figure F.21.
 17. With the 7/16" wrench, loosen (do not remove) the generator brush holder clamping bolt. Note the drill spot for reassembly. See Figure F.21.
 18. Carefully pry the stator/end bracket assembly away from the generator frame.
- NOTE:** The generator brush holder assembly will also be removed.

Replacement

19. Mount the stator/end bracket assembly to the generator frame. Line up the mating parts at the stator end bracket drill spot. Tighten the four mounting bolts with the 5/8" wrench.
20. Check armature air gap. Minimum gap is .035." Loosen the four mounting bolts; adjust and re-tighten if necessary.
21. Tighten the generator brush holder assembly with the 7/16" wrench. Note brush holder drill spot.
22. Connect the four heavy cables from the generator frame coils to the generator brush holders.
23. Install the eight commutator brushes according to how you marked their positions at disassembly.
24. Attach the black lead to the positive terminal of the field rectifier bridge. Attach the red lead to the negative terminal.
25. Attach the white auxiliary power lead to the 115 VAC receptacle. Attach the red auxiliary power lead to the CB4 circuit breaker. Attach the black auxiliary power lead to the current transformer. Tape the bolted connection.
26. Connect the two yellow leads to the field bridge and to the field fuse holder. Connect the white and yellow wires at the in-line connectors.
27. Install the commutator wraparound, the bottom alternator cover, the battery, and the alternator brush holder assembly.
28. Install the alternator rotor according to the reassembly directions in the **Alternator Rotor Removal and Replacement** procedure. Before installing the case top and sides, replace any cable ties cut for disassembly.

Classic III and IIID



TROUBLESHOOTING & REPAIR

GENERATOR FRAME REMOVAL AND REPLACEMENT

WARNING

Service and repair should be performed by only Lincoln Electric factory trained personnel. Unauthorized repairs performed on this equipment may result in danger to the technician or machine operator and will invalidate your factory warranty. For your safety and to avoid electrical shock, please observe all safety notes and precautions detailed throughout this manual.

If for any reason you do not understand the test procedures or are unable to perform the test/repairs safely, contact the Lincoln Electric Service Department for electrical troubleshooting assistance before you proceed. Call 216-383-2531 or 1-888-935-3877.

DESCRIPTION

This procedure will aid the technician in the removal and replacement of the DC generator frame.

MATERIALS NEEDED

- Rope sling
- 3/4" wrench
- 1/2" wrench
- 9/16" wrench
- Wood or steel blocks
- Pry bars

Classic III and IIID



TROUBLESHOOTING & REPAIR

GENERATOR FRAME REMOVAL AND REPLACEMENT (*continued*)

FIGURE F.22 – FUEL TANK / OUTPUT CABLE REMOVAL

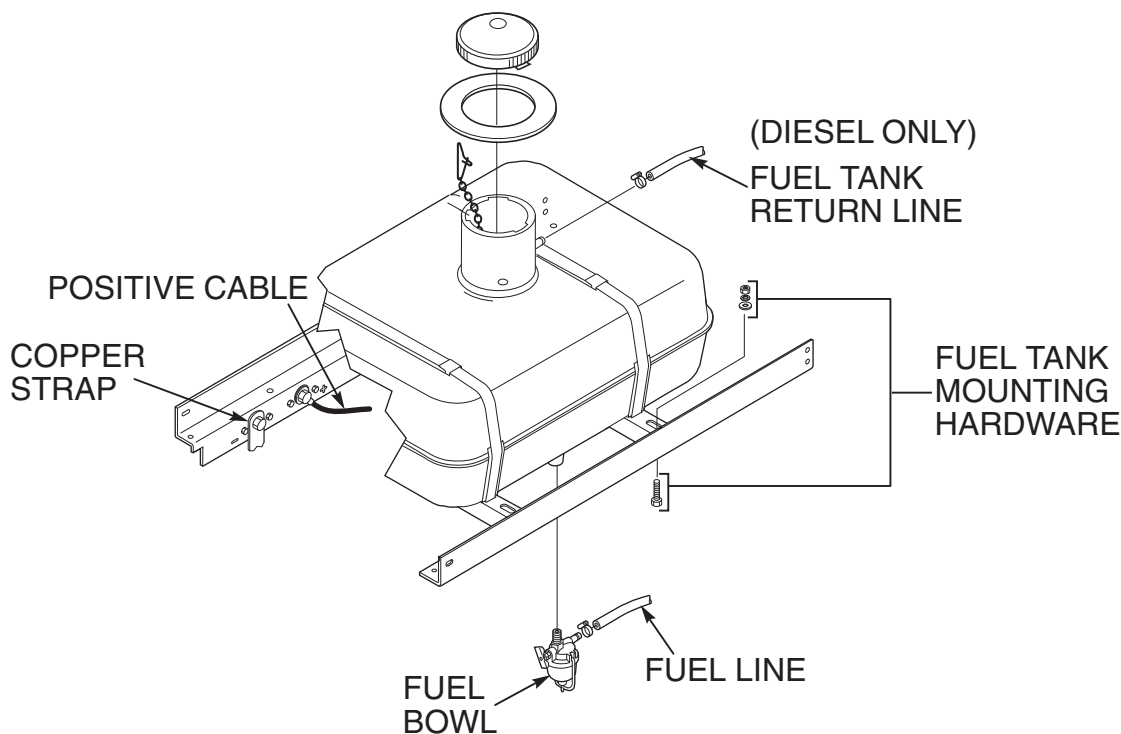

PROCEDURE

1. Turn the engine OFF.
2. Perform the **Alternator Rotor Removal** procedure.
3. Perform the **Alternator Stator Removal** procedure.

See Figure F.22 for steps 4 - 9.

4. Turn off the fuel at the fuel bowl and remove the fuel line. Plug the line to prevent spillage.
5. Remove the fuel return line from the top of the fuel tank (diesel engine only).
6. With the 9/16" wrench, remove the four nuts, bolts, and washers that mount the fuel tank to the rails.

7. Carefully remove the fuel tank.

NOTE: At reassembly, the fuel line may have to be purged. See the **Maintenance** section (Diesel only).

8. With the 3/4" wrench, remove the copper strap/reed switch assembly from the negative output terminal. Clear the strap.
9. With the 3/4" wrench, remove the cable from the positive output terminal.

Classic III and IIID



TROUBLESHOOTING & REPAIR

GENERATOR FRAME REMOVAL AND REPLACEMENT (*continued*)

FIGURE F.23 - WIRE AND SELECTOR SWITCH CONNECTIONS

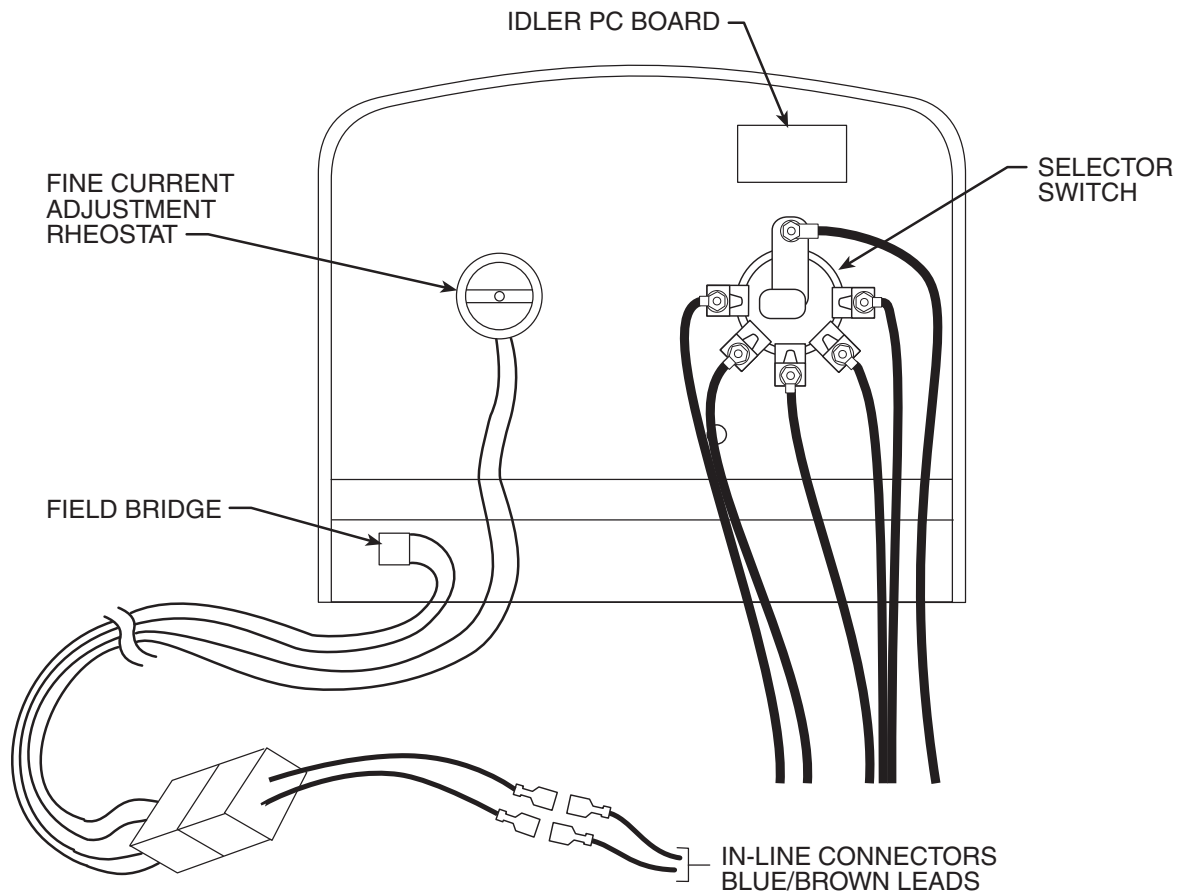

See Figure F.23 for steps 10 - 13.

10. Cut all necessary cable ties.
11. Disconnect the blue and the brown wires at the in-line connectors. See Figure F.23 and the Wiring Diagram.
12. Label the cables that are connected to the selector switch. Otherwise, you will need to see the Wiring Diagram during reassembly.
13. With the 1/2" wrench, remove the cables connected to the selector switch.

Classic III and IIID



TROUBLESHOOTING & REPAIR

GENERATOR FRAME REMOVAL AND REPLACEMENT (*continued*)

FIGURE F.24 – CASE FRONT REMOVAL

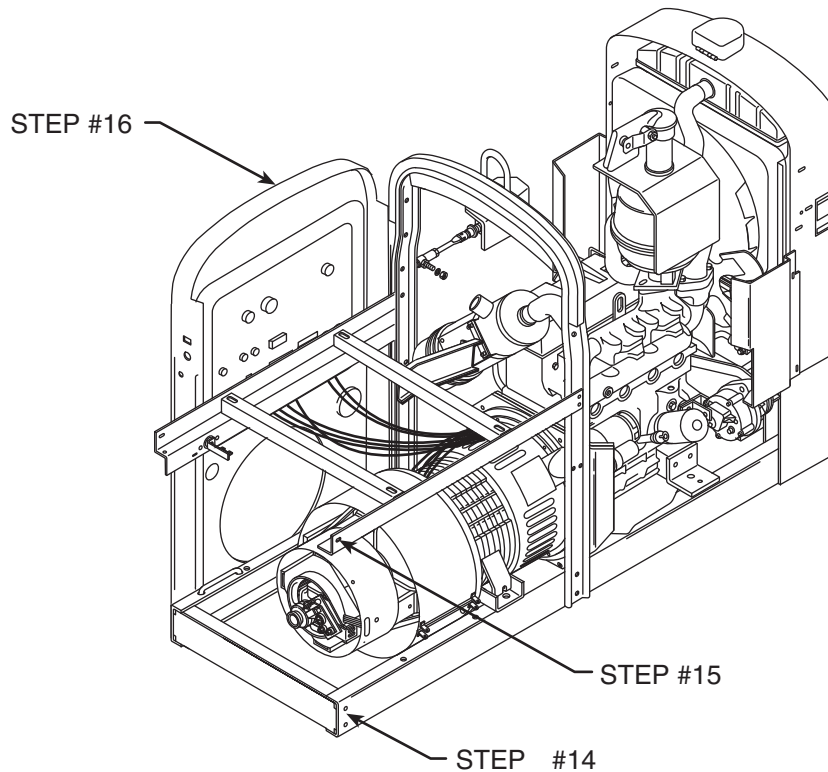

See Figure F.24 for steps 14 - 16.

14. With the 9/16" wrench, remove the four bolts and lock washers holding the case front to the welder frame. There are two bolts on each side.
15. With the 1/2" wrench, remove the two bolts and nuts and washers from the fuel tank rails - one on each side.
16. Carefully clear and disconnect any necessary remaining leads and lift up and set the front panel assembly to the left side of the machine. Make sure all leads are clear.

Classic III and IIID



GENERATOR FRAME REMOVAL AND REPLACEMENT *(continued)*

FIGURE F.25 – FRAME MOUNTING DETAILS

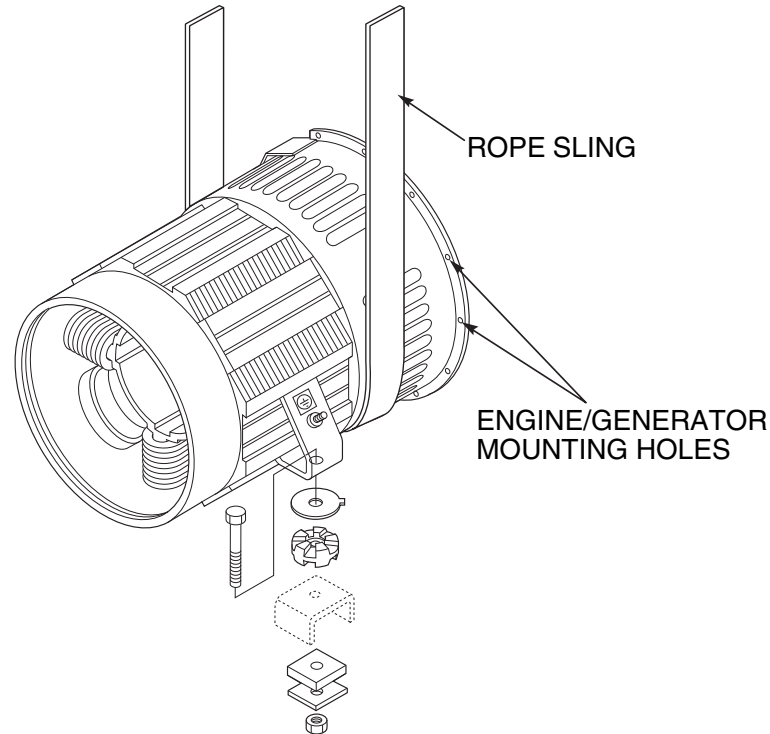

See Figure F.25 for steps 17 - 20.

17. With the 3/4" wrench, remove the frame mounting bolts, nuts and spacers from the feet of the generator frame.
18. With the rope sling around the generator frame, carefully lift the frame and engine assembly a small distance. Slide the wood or steel block under the engine adapter plate.
19. With the 9/16" wrench, remove the bolts mounting the engine to the generator frame.
20. Using the rope sling and pry bars, carefully lift and "wiggle" the generator frame away from the engine and armature assembly. Be careful to support the generator frame as you remove it.

Replacement

21. Support the generator frame with the rope sling. Mount the generator frame to the engine and armature assembly. Before removing the rope sling, be careful to support the generator frame with the wood or steel block under the engine adapter plate. With the 9/16" wrench, install the bolts that attach the generator frame to the engine.
22. With the 3/4" wrench, install the frame mounting bolts, nuts, and spacers to the feet of the generator frame. See Figure F.25.
23. Install the case front to the welder frame. **See steps 14 - 16.**
24. Connect the cables to the selector switch according to how you labeled them during disassembly. See the Wiring Diagram if necessary.
25. Reconnect the blue and brown leads at the in-line connectors.
26. Install the copper strap/reed switch assembly to the negative output terminal.

Classic III and IIID



TROUBLESHOOTING & REPAIR

GENERATOR FRAME REMOVAL AND REPLACEMENT *(continued)*

27. Re-attach the positive output terminal cable.
28. Set the fuel tank into position on the rails and secure it with the four bolts, washers, and nuts.
29. Attach the fuel return line at the top of the fuel tank (Diesel engine only). Remove the plug from the fuel line and attach it to the fuel bowl.
30. Perform the replacement procedures according to each of the following:

Alternator Stator Removal and Replacement

Alternator Rotor Removal and Replacement

Before installing the machine case top and sides, be sure to replace any cable ties cut during disassembly.

Classic III and IIID



TROUBLESHOOTING & REPAIR

GENERATOR ARMATURE REMOVAL AND REPLACEMENT



WARNING

Service and repair should be performed by only Lincoln Electric factory trained personnel. Unauthorized repairs performed on this equipment may result in danger to the technician or machine operator and will invalidate your factory warranty. For your safety and to avoid electrical shock, please observe all safety notes and precautions detailed throughout this manual.

If for any reason you do not understand the test procedures or are unable to perform the test/repairs safely, contact the Lincoln Electric Service Department for electrical troubleshooting assistance before you proceed. Call 216-383-2531 or 1-888-935-3877.

DESCRIPTION

This procedure will aid the technician in the removal and replacement of the main armature.

MATERIALS NEEDED

- Rope sling
- 5/8" wrench
- Wood or steel blocks

Classic III and IIID



Return to Section TOC
Return to Master TOC

Return to Section TOC
Return to Master TOC

Return to Section TOC
Return to Master TOC

Return to Section TOC
Return to Master TOC

TROUBLESHOOTING & REPAIR

GENERATOR ARMATURE REMOVAL AND REPLACEMENT (*continued*)

FIGURE F.26 – BLOWER PADDLE REMOVAL

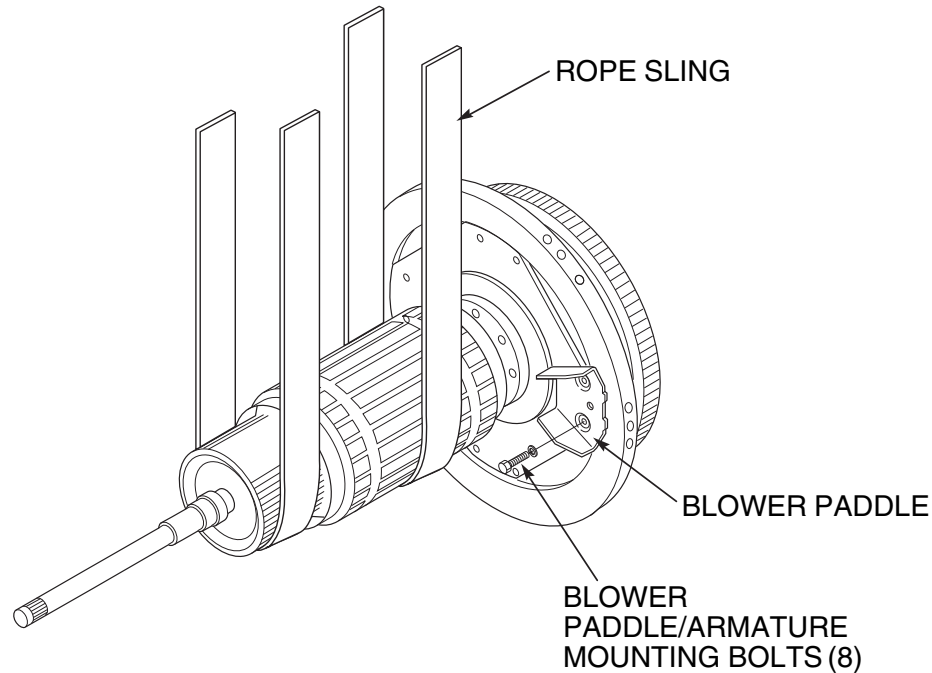

PROCEDURE

1. Turn the engine OFF.
2. Perform the **Alternator Rotor Removal** procedure.
3. Perform the **Alternator Stator Removal** procedure.
4. Perform the **Generator Frame Removal** procedure.
5. Using the rope sling, support the armature.
6. Make sure the engine is supported with the wood or steel blocks.
7. With the 5/8" wrench, remove the eight bolts and lock washers holding the blower paddles and the armature to the engine flywheel. See Figure F.26.
8. With the armature supported and "balanced" in the rope sling, carefully rotate the armature 1/8 turn in either direction to release.

CAUTION

The armature is now free to be removed from the engine.

Replacement

9. Support the armature with the rope sling. Mount the armature to the engine, rotating it 1/8 of a turn in either direction to achieve proper attachment. Before removing the rope sling, be careful to support the armature with the wood or steel blocks under the engine. With the 5/8" wrench, install the eight bolts and lock washers that attach the blower paddles and the armature to the engine flywheel.
10. Perform the replacement procedures according to each of the following:

Generator Frame Removal and Replacement

Alternator Stator Removal and Replacement

Alternator Rotor Removal and Replacement

Classic III and IIID



TROUBLESHOOTING & REPAIR

RETEST AFTER REPAIR

Retest a machine:

- If it is rejected under test for any reason that requires you to remove any mechanical part which could affect the machine's electrical characteristics. OR
- If you repair or replace any electrical components.

ENGINE OUTPUT

Mode	No Load RPM	Load RPM
Low Idle	1325 - 1475	NA
High Idle	1780 - 1810	1650 - 1750

WELDER DC OUTPUT

Current Control Rheostat	Current Selector Switch	Open Circuit Voltage	Load Volts	Load Amps
Maximum	Maximum	91 - 98.5	36 - 45 Gas	350
Maximum	Maximum	91 - 98.5	38 - 47 Diesel	350

AC AUXILIARY POWER RECEPTACLE OUTPUT

230 Volt Receptacle			115 Volt Receptacle		
Open Circuit Voltage	Load Volts	Load Amps	Open Circuit Voltage	Load Volts	Load Amps
240 - 254	210 - 225	13.8	118 - 128	103 - 112	26.0

FIELD AMPS AND VOLTS (Current Rheostat at Maximum)

Exciter DC Volts	Shunt Field Amps	Alt. Rotor Amps	RPM
123 - 133	2.0 - 2.4	2.2 - 2.6	1780 - 1810

NOTES

Return to Section TOC
Return to Master TOC
Return to Section TOC
Return to Master TOC
Return to Section TOC
Return to Master TOC
Return to Section TOC
Return to Master TOC
Return to Section TOC
Return to Master TOC

Classic III and IIID



TABLE OF CONTENTS
ELECTRICAL DIAGRAMS SECTION

Electrical Diagrams Section.....Section G

Wiring DiagramG-3

Wiring DiagramG-5

Wiring Diagram Wire Feed Module.....G-7

Idler PC Board SchematicG-9

Idler PC Board LayoutG-11

Return to Master TOC

Return to Master TOC

Return to Master TOC

Return to Master TOC

Return to Section TOC
Return to Master TOC
Return to Section TOC
Return to Master TOC
Return to Section TOC
Return to Master TOC
Return to Section TOC
Return to Master TOC

CLASSIC III/IIID



CLASSIC IIIID WIRING DIAGRAM

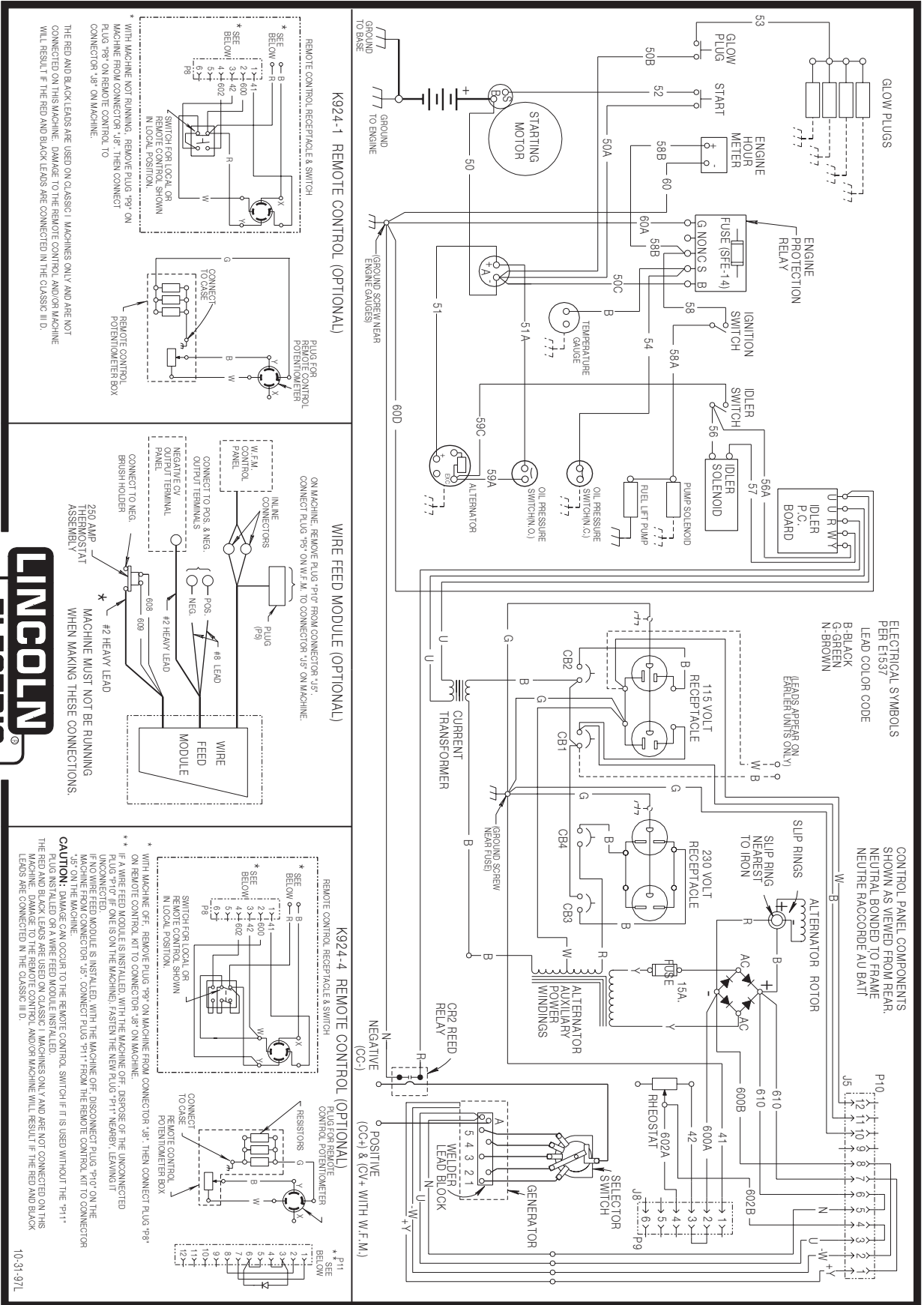

ELECTRICAL SYMBOLS PER E1597
LEAD COLOR CODE
B-BLACK
G-GREEN
N-BROWN

CONTROL PANEL COMPONENTS SHOWN AS VIEWED FROM REAR, NEUTRAL BONDED TO FRAME NEUTRE RACCORDRE AU BATT

*LEADS APPEAR ONLY IN EARLIER UNITS ONLY



CLEVELAND, OHIO U.S.A.

10-31-97L

19280

NOTE: This diagram is for reference only. It may not be accurate for all machines covered by this manual. The wiring diagram specific to your code is pasted inside one of the enclosure panels of your machine.

CLASSIC III/IIID



Return to Section TOC

Return to Section TOC

Return to Section TOC

Return to Section TOC

Return to Section TOC

Return to Section TOC

Return to Section TOC

Return to Section TOC

Return to Section TOC

Return to Section TOC

Return to Master TOC

Return to Master TOC

Return to Master TOC

CLASSIC III/IIID



Wiring Diagram- Classic III

CLASSIC III - WIRING DIAGRAM

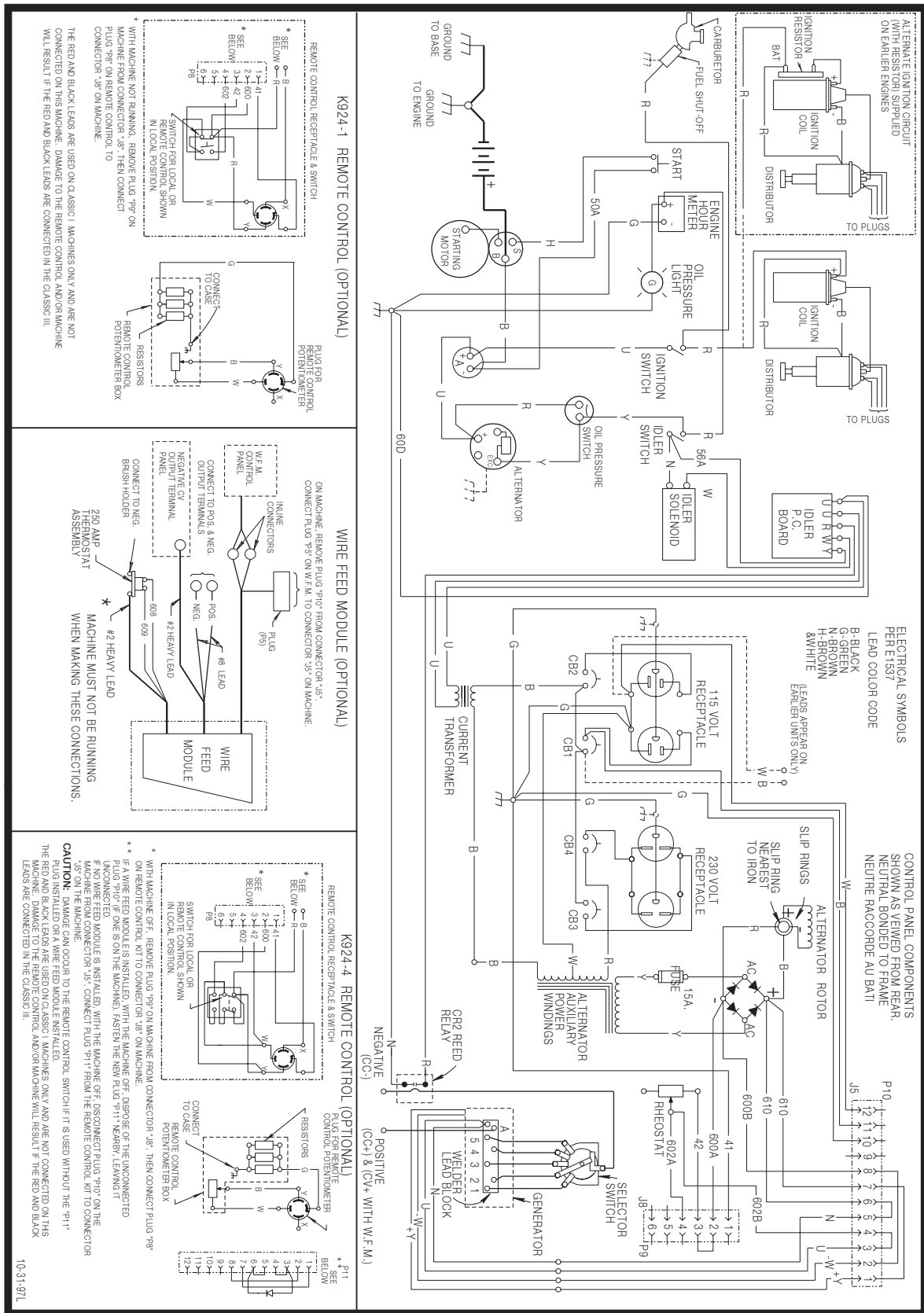

NOTE: Lincoln Electric assumes no responsibility for liabilities resulting from board level troubleshooting. PC Board repairs will invalidate your factory warranty. **Individual Printed Circuit Board Components are not available from Lincoln Electric.** This information is provided for reference only. Lincoln Electric discourages board level troubleshooting and repair since it may compromise the quality of the design and may result in danger to the Machine Operator or Technician. Improper PC board repairs could result in damage to the machine.

CLASSIC III/IIID



Return to Section TOC

19263

Return to Master TOC

Return to Section TOC

Return to Master TOC

Return to Section TOC

Return to Master TOC

Return to Section TOC

Return to Master TOC

Return to Section TOC

Return to Master TOC

Return to Section TOC

Return to Master TOC

Return to Section TOC

Return to Master TOC

Return to Section TOC

Return to Master TOC

Return to Section TOC

Return to Master TOC

Return to Section TOC

Return to Master TOC

Return to Section TOC

Return to Master TOC

Return to Section TOC

Return to Master TOC

Return to Section TOC Return to Section TOC Return to Section TOC
Return to Master TOC Return to Master TOC Return to Master TOC

CLASSIC III/IIID



Return to Section TOC Return to Section TOC Return to Section TOC
Return to Master TOC Return to Master TOC Return to Master TOC

CLASSIC III/IIID



Idler PC Board Schematic

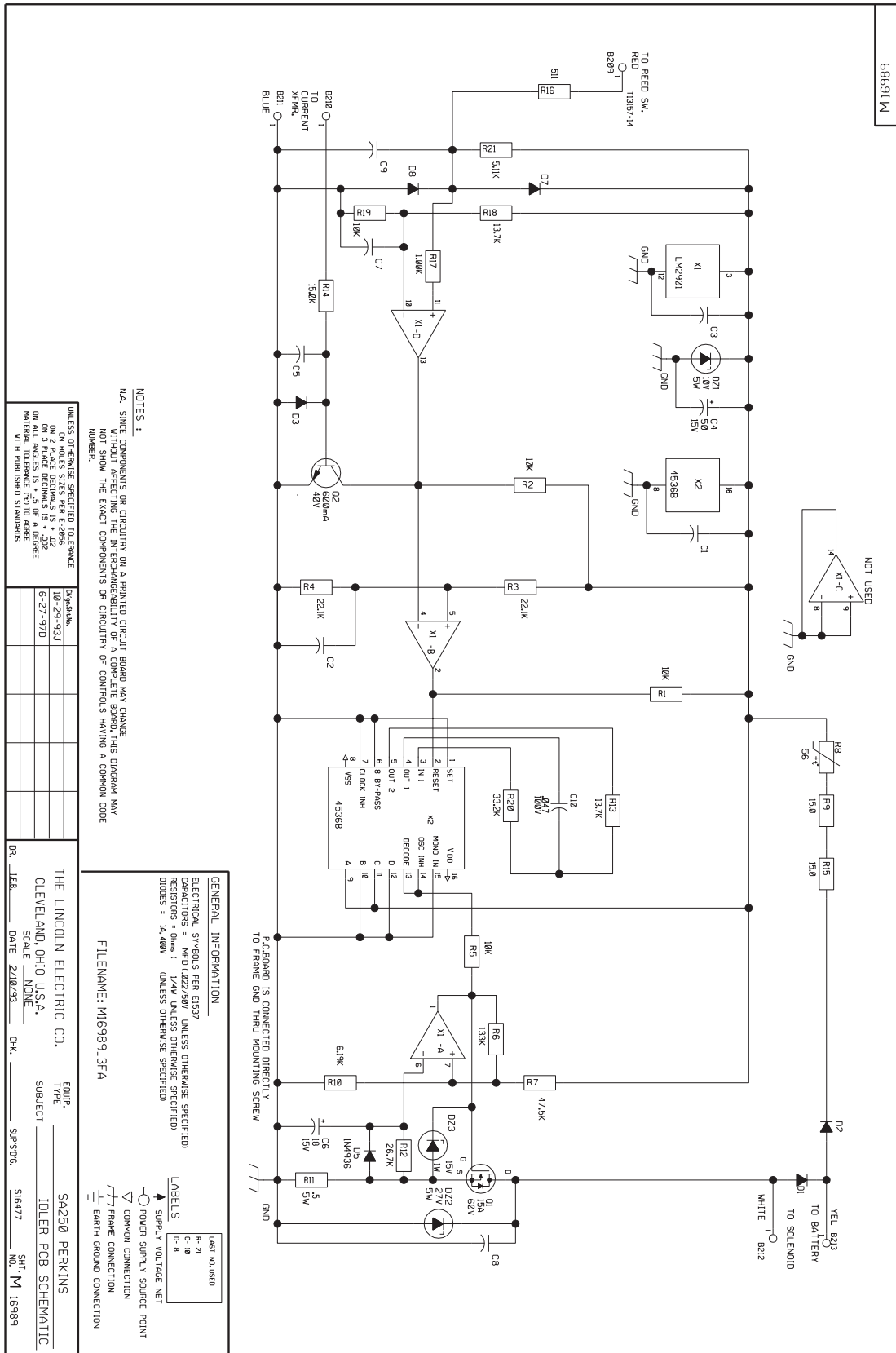

NOTE: Lincoln Electric assumes no responsibility for liabilities resulting from board level troubleshooting. PC Board repairs will invalidate your factory warranty. **Individual Printed Circuit Board Components are not available from Lincoln Electric.** This information is provided for reference only. Lincoln Electric discourages board level troubleshooting and repair since it may compromise the quality of the design and may result in danger to the Machine Operator or Technician. Improper PC board repairs could result in damage to the machine.

CLASSIC III/IIID



Return to Section TOC

Return to Master TOC

Return to Section TOC

Return to Master TOC

Return to Section TOC

Return to Master TOC

Return to Section TOC

Return to Master TOC

Return to Section TOC
Return to Master TOC
Return to Section TOC
Return to Master TOC
Return to Section TOC
Return to Master TOC
Return to Section TOC
Return to Master TOC

CLASSIC III/IIID



Idler PC Board Layout

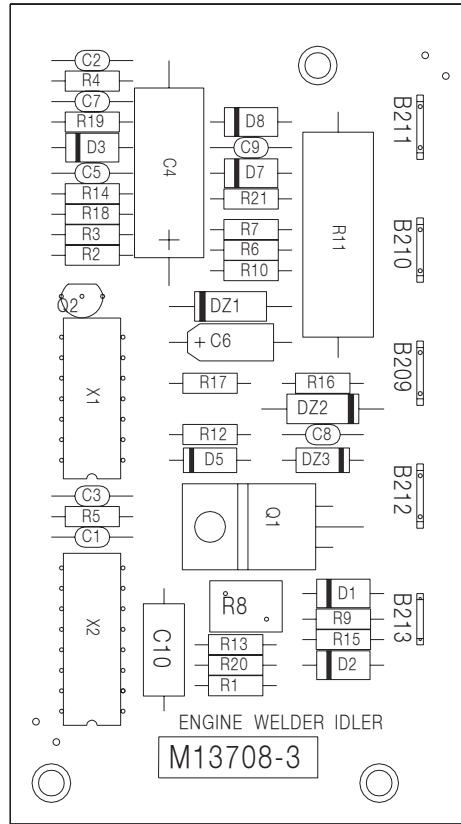

ITEM	REV'D	PART NO	DESCRIPTION
B209, B210, B211, B212	4	T13157-14	TAB TERMINAL
B213	1	T13157-15	TAB TERMINAL
C1, C2, C3, C5, C7, C8, C9	7	S16688-5	.022/50
C4	1	S13490-35	50/16
C6	1	S13490-39	18/15
C10	1	S13490-102	.047/100
D1, D2, D3, D7, D8	5	T12199-1	1N4004
D5	1	T12705-34	1N4936
D71	1	T12702-33	1N5347B
D22	1	T12702-17	1N5361B ZENER DIODE
D23	1	T12702-29	1N4744A
Q1	1	T12704-54	N-CHANNEL FET (SS)
O2	1	T12704-68	2N4401
R1, R2, R5, R19	4	S19400-1002	10K 1/4W
R3, R4	2	S19400-2212	22.1K 1/4W
R6	1	S19400-1333	133K 1/4W
R7	1	S19400-4752	47.5K 1/4W
R8	1	S18380-1	PTC THERMISTOR
R9, R15	2	S19400-1580	15 1/4W
R10	1	S19400-6191	6.19K 1/4W
R11	1	T12300-80	5 WATT 0.5 OHM RESISTOR
R12	1	S19400-2672	26.7K 1/4W
R13, R18	2	S19400-1372	13.7K 1/4W
R14	1	S19400-1502	15K 1/4W
R16	1	S19400-5110	5.11 1/4W
R17	1	S19400-1001	1K 1/4W
R20	1	S19400-3322	33.2K 1/4W
R21	1	S19400-5111	5.11K 1/4W
X1	1	S15128-11	14 PIN QUAD COMPARATOR
X2	1	S15018-13	16 PIN I.C. (SS)

CAPACITORS = MFD/VOLTS
RESISTORS = OHMS

NOTE: Lincoln Electric assumes no responsibility for liabilities resulting from board level troubleshooting. PC Board repairs will invalidate your factory warranty. **Individual Printed Circuit Board Components are not available from Lincoln Electric.** This information is provided for reference only. Lincoln Electric discourages board level troubleshooting and repair since it may compromise the quality of the design and may result in danger to the Machine Operator or Technician. Improper PC board repairs could result in damage to the machine.

CLASSIC III/IIID



Return to Section TOC

Return to Master TOC

Return to Section TOC

Return to Master TOC

Return to Section TOC

Return to Master TOC

Return to Section TOC

Return to Master TOC

Return to Section TOC
Return to Master TOC
Return to Section TOC
Return to Master TOC
Return to Section TOC
Return to Master TOC
Return to Section TOC
Return to Master TOC

CLASSIC III/IIID

