

REPLACEMENT PARTS LIST HEAVY DUTY AC-DC WELDER

SEE OTHER SIDE FOR PARTS LISTING

110-078, Five Star

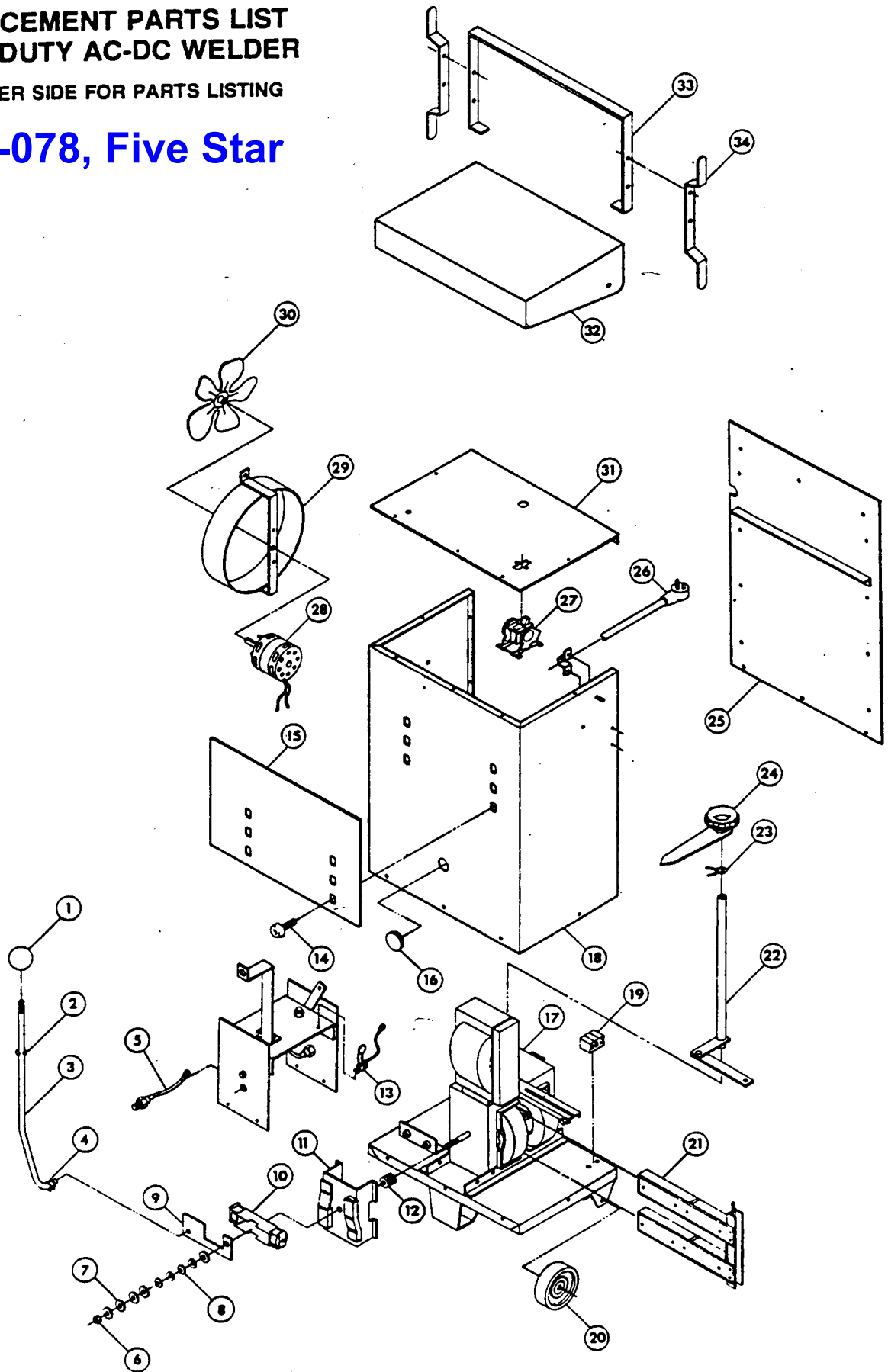

110-078, 295 amp AC / 250 amp DC Five Star Arc Welder

Item	Lincoln Stock #	Customer #	Description
1		312-031-000	Clamp knob
2		078-010-000	Retaining ring
3		311-089-000	Clamp rod kit
4		078-007-000	Retaining ring
5	214-004-666	214-004-666	Diode assy.
6		069-010-000	Locking nut 3/8 - 16
7		311-085-000	Thrust washer
8		330-017-000	Spring washer
9		311-090-000	Clamping arm
10		860-119-000	Clamp roller assy.
11		860-184-100	Shunt clamp assy.
12		310-101-000	Counter spring
13		860-189-000	Transient voltage protector
14	312-045-666	312-028-100	Receptacle assy.
15		711-087-010	Front faceplate
16		078-008-100	Snap plug
17		860-190-000	Base & Transformer
18	NLA	860-180-100	Case assembly
19		239-057-000	Terminal block

Item	Lincoln Stock #	Customer #	Description
20		413-010-000	Wheel
21		860-186-666 (use 860-121-000)	Shunt
22		860-294-000	Dial linkage assy.
23		078-009-000	Retainer clip
24		860-293-000	Dial indicator assy.
25		860-172-100	Back panel
26		218-019-000	Power cord
27	216-010-666	216-010-666	Power switch
28		216-038-000	Fan motor assy.
29		860-179-100	Fan shroud assy.
30		316-008-100	Fan Blade
31		410-187-100	Dial plate
32		860-173-000	Hood
33		412-095-200	Handle
34		412-096-200	Cable wrap

Not Shown

32		238-009-500 (4007)	12', 3 ga. ground cable w/clamp
33		238-085-500 (4017)	18', 3 ga. Electrode cable w/holder
34	239-052-908	4031	Male plug pair

5/29/2009

Manufactured from 2-9-75 until 3-27-81 (56,862)

Model	Primary Input	Input Plug	Duty Cycle at Rated Output
110-078	230V	NEMA 6-50P	20%

First Serial # W163708

Last Serial # W631835

Rated Output	Voltage Settings	Agency Listing	Max Output
295 / 250	Infinite	UL	295 amps

110-078, Five Star

295 AMP AC
CONNECTORS

250 AMP DC
CONNECTORS

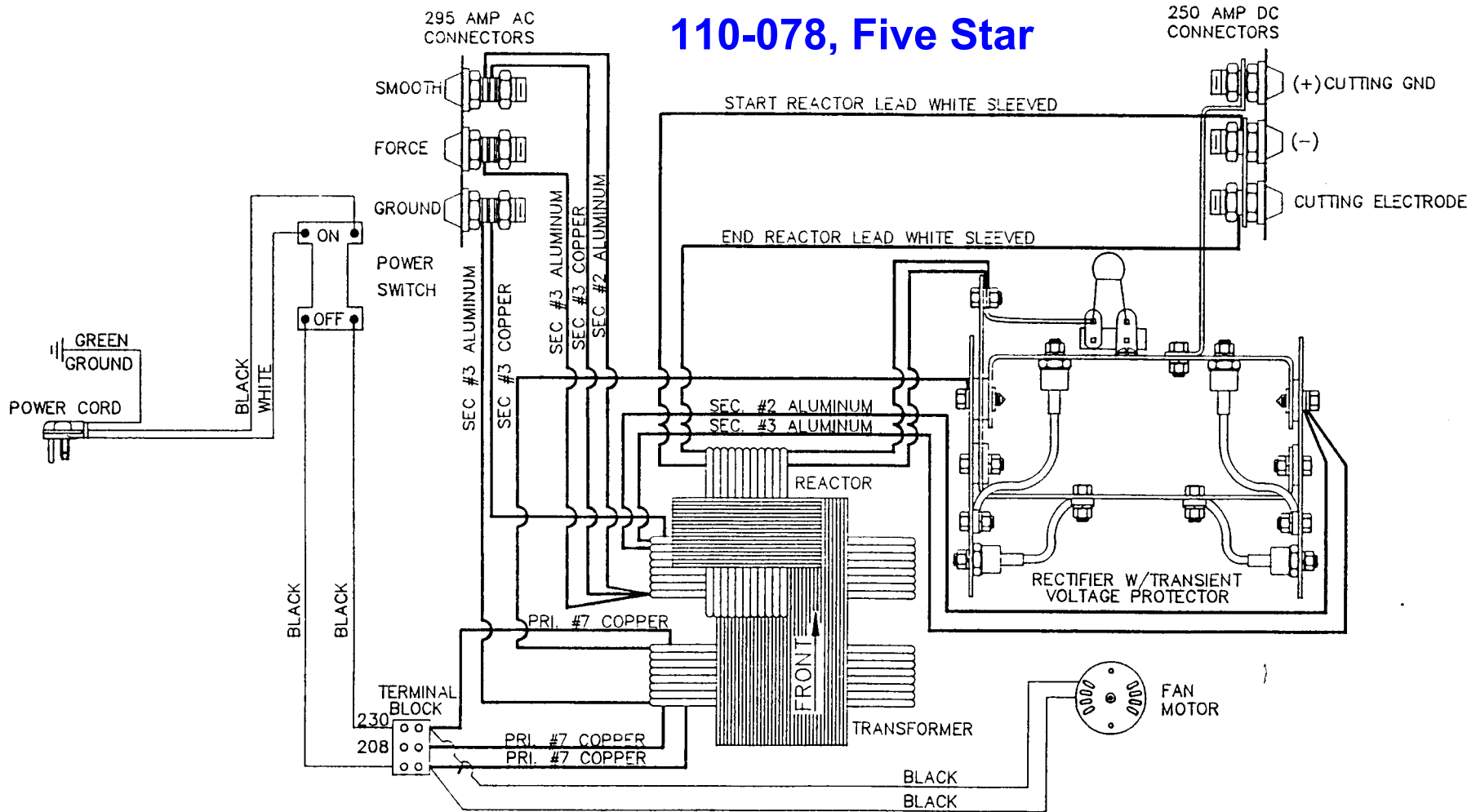

110-078, 110-119, 110-178

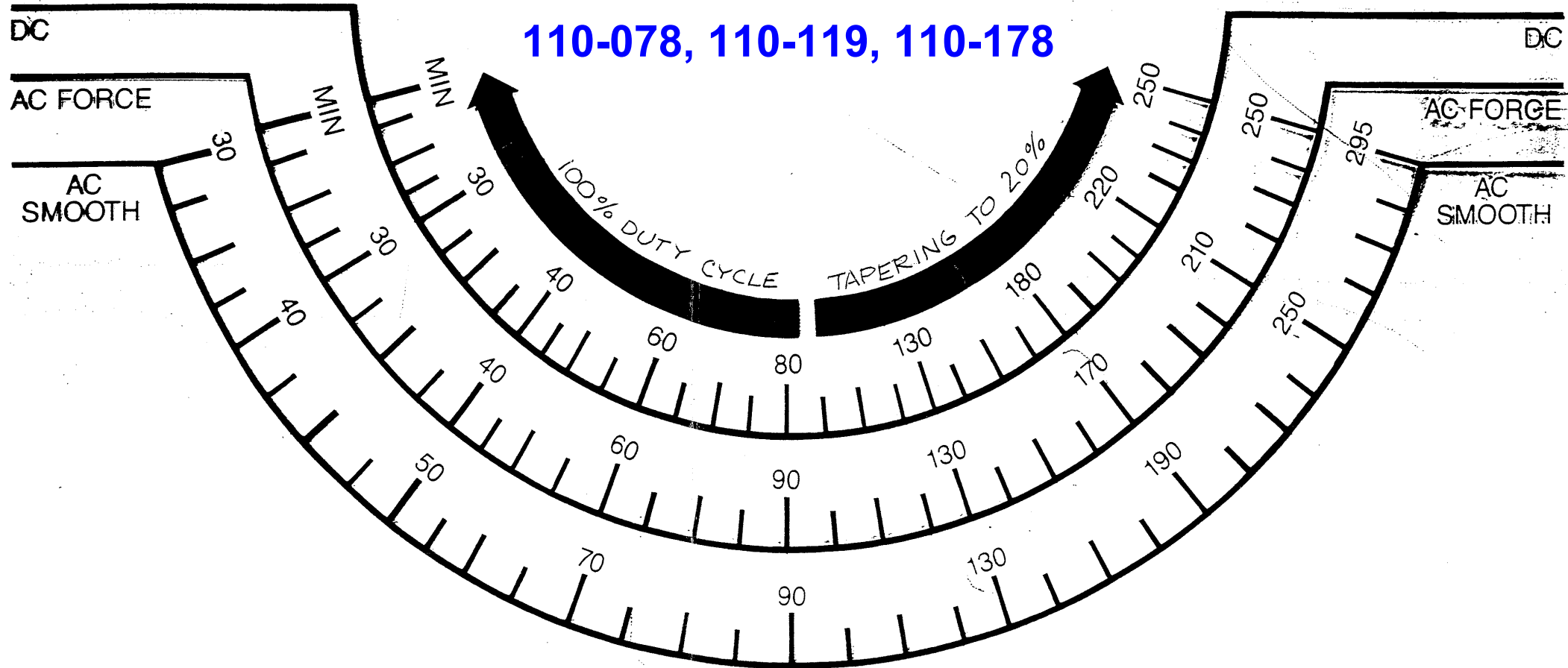

SHUNT LUBRICATING PROCEDURE FOR 110-119-000

1. Unplug Welder!!
2. Remove back of welder.
3. Release shunt lock.
4. Move shunt out of transformer to the end of shunt guide (maximum dial setting).
5. Apply silicone grease (stock # 098-068-000) to the exposed bevel surface (8).
6. Turn dial indicator from maximum position to minimum position a number of times to work in silicone grease. Repeat steps 4 & 5 if shunt does not move freely.
7. In most cases the shunt lock will have to be readjusted. To do this follow maintenance instructions in lower right hand corner of decal on the inside top cover of welder.

NOTE: If shunt still binds, see Shunt Adjusting Procedure for 110-119-000

Also valid for:
110-078
110-178

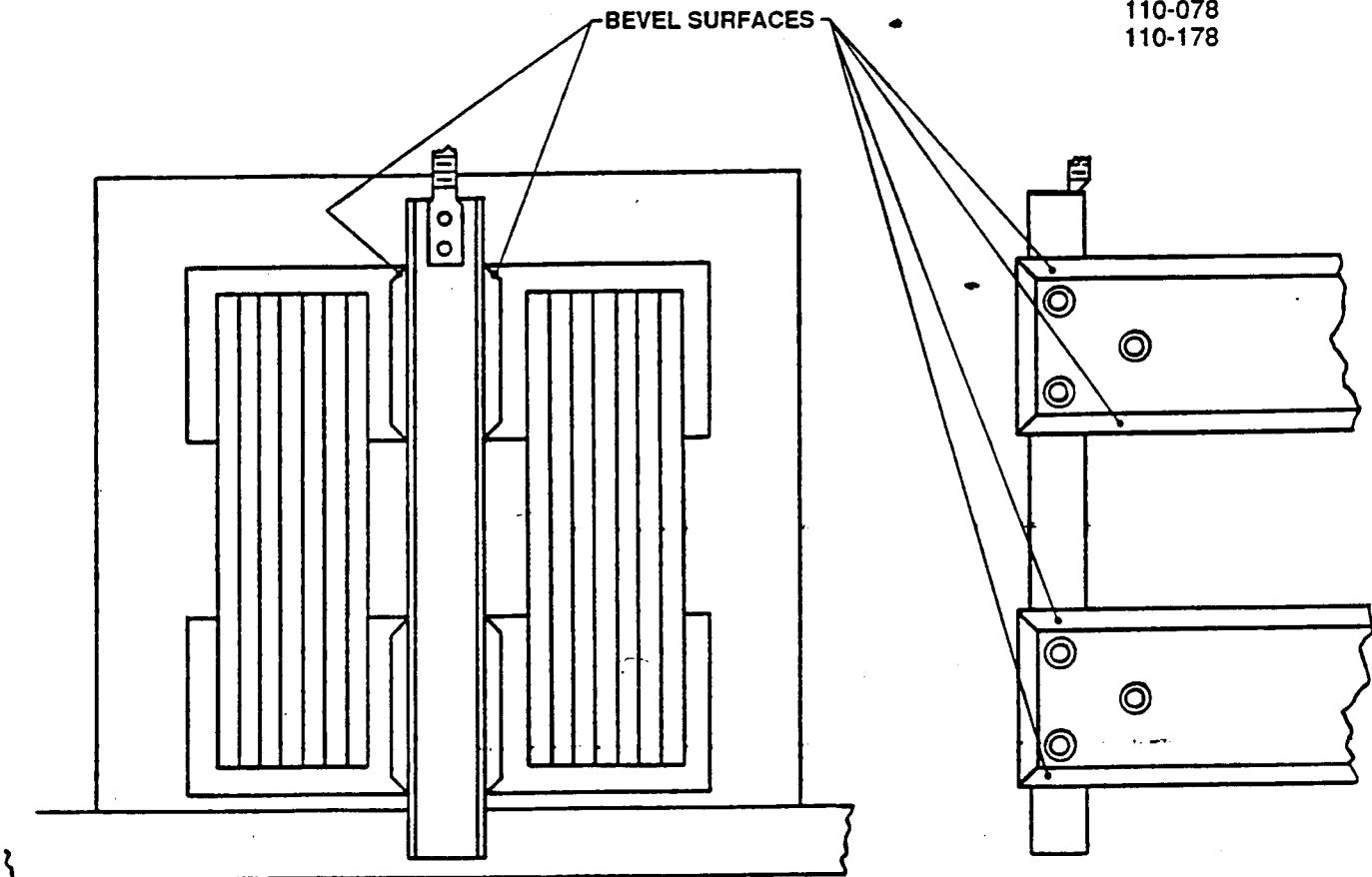

END VIEW OF TRANSFORMER AND SHUNT

VIEW FROM BACK OF WELDER

SHUNT ADJUSTING PROCEDURE FOR 110-119-000

1. **Unplug Welder!!**
2. Remove the back of the welder.
3. With shunt in the innermost position (as shown) check tightness of nut so that the washer moves without too much force.

If washer moves freely with no pressure from the nut, tighten more.

If the washer cannot be moved then the nut is too tight and should be loosened up a little.

It should be possible to move the washer without too much force.

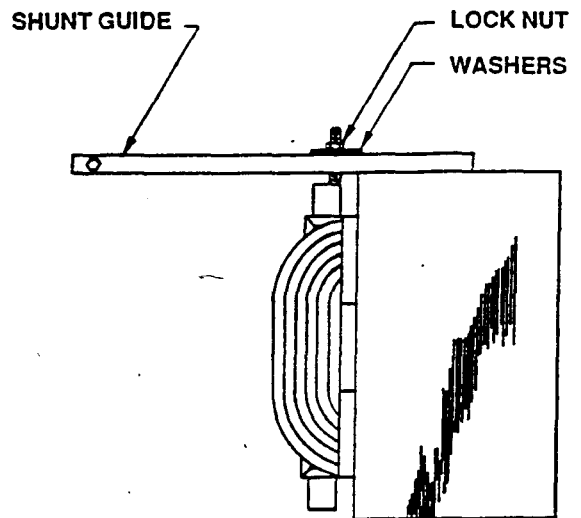

4. After nut has been tightened, pull shunt out of the transformer to the end of the shunt guide. If shunt moves out and back the full distance of the shunt guide without binding or sticking then no more adjusting is necessary.

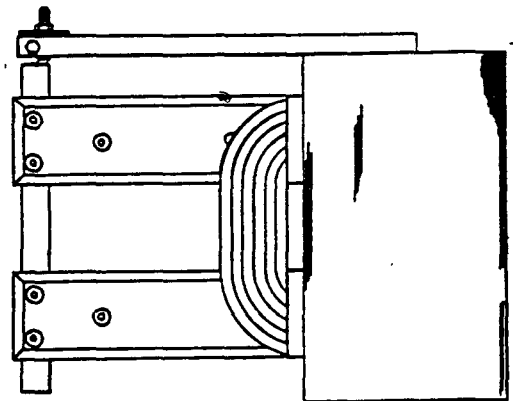

5. If shunt binds or sticks at all when moved back and forth along the guide then the guide is bent.

If the washer drops down away from the nut leaving more space between it and the nut then the guide is bent down and must be tapped back up.

PUSH IN SHUNT AND TAP UP END OF SHUNT GUIDE

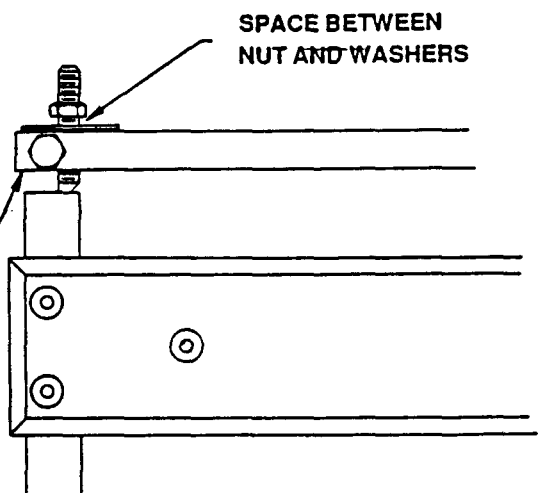

**PUSH IN SHUNT AND TAP DOWN ON
SHUNT GUIDE**

If the washer is so tight in the extended position that it cannot be moved without moving the whole shunt then the shunt guide is bent upward and must be tapped down until shunt moves in and out freely.

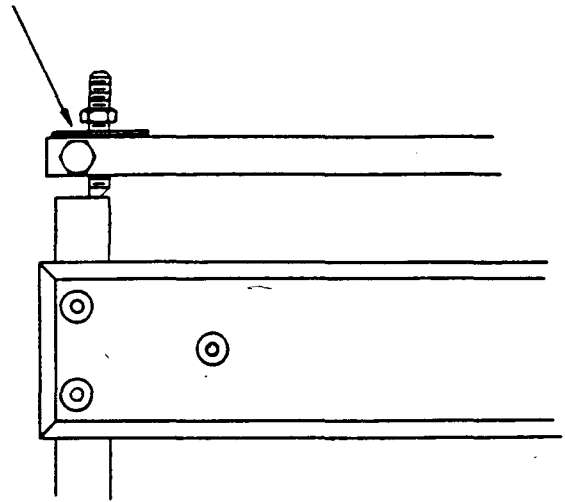

When tapping guide either up or down both sides must be tapped equally so that washer does not become cocked.