

INVERTEC® 400TP

Spare Parts.....	1
Figure A: Machine Assembly	2
Figure B: Inside Machine Assembly.....	4
Figure C: Front Assembly.....	5
Miscellaneous Items (not shown in figure A, B, C,)	5
Electrical Schematic.....	6
CODE: 50618, 50739	6



Spare Parts

SP50618, SP50739 REV02
10/2024

ASSEMBLY PAGE NAME			Machine Assembly	Machine Assembly	Machine Assembly	Miscellaneous Items		
CODE NO.:	K NO.:	FIGURE NO.:	A	B	C	-		
50618	K14390-1	INVERTEC® 400TP	1	1	1	1		
50739	K14390-1	INVERTEC® 400TP	2	2	2	2		

*items highlighted in bold are recommended spare parts

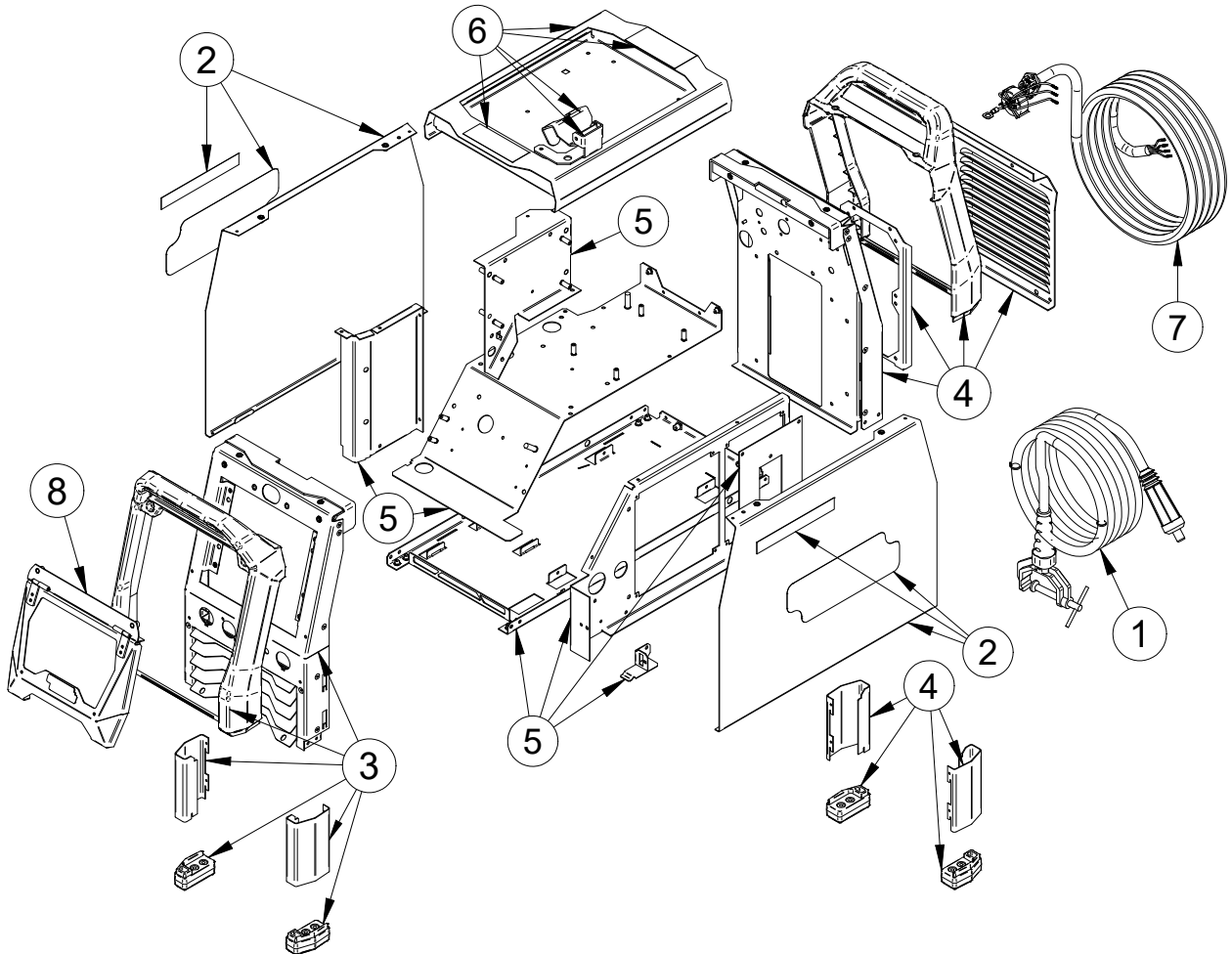

Figure A

Figure A: Machine Assembly

Item	Description	Part Number	QTY	1	2	3	4	5	6	7
1	RETURN WELDING CABLE	GRD-400A-70-5M	1	X	X					
2	SIDE PANEL KIT includes:	T-8040-198-1R	1	X	X					
	SIDE PANEL		2							
	LINCOLN ELECTRIC SIDE LABEL		2							
	INVERTEC® LABEL		2							
3	FRONT PANEL KIT includes:	T-8040-199-1R	1	X	X					
	FRONT HANDLE CASE COMPLETE		1							
	FRONT PANEL ASSEMBLY		1							
	RIGHT COVER		1							
	FOOT		1							
	LEFT COVER		1							
	FOOT		1							
4	REAR PANEL KIT includes:	T-8040-200-1R	1	X						
	FRONT HANDLE CASE COMPLETE		1							
	BACK PANEL ASSEMBLY		1							
	LABEL F1/2A		1							
	LABEL F2/2A		1							
	GAS LABEL		1							
	COVER		1							
	BRACKET		1							
	RIGHT COVER		1							
	FOOT		1							
	LEFT COVER		1							
	FOOT		1							
4	REAR PANEL KIT includes:	T-8040-200-2R	1		X					
	FRONT HANDLE CASE COMPLETE		1							
	BACK PANEL ASSEMBLY		1							
	LABEL F1/2A		1							
	LABEL F2/2A		1							
	GAS LABEL		1							
	COVER		1							
	BRACKET		1							
	RIGHT COVER		1							
	FOOT		1							
	LEFT COVER		1							
	FOOT		1							
5	BASE, PARTITION, SHELF KIT includes:	T-8040-201-1R	1	X						
	BASE ASSEMBLY		1							
	BRACKET		1							
	SHELF ASSEMBLY		1							
	PARTITION ASSEMBLY		1							
	PARTITION ASSEMBLY		1							
	BRIDGE BRACKET		1							
	BRACKET		1							

5	BASE, PARTITION, SHELF KIT includes:	T-8040-201-2R	1							
	BASE ASSEMBLY		1							
	BRACKET		1							
	SHELF ASSEMBLY		1							
	PARTITION ASSEMBLY		1		X					
	PARTITION ASSEMBLY		1							
	BRIDGE BRACKET		1							
	BRACKET		1							
6	COVER KIT includes:	T-8040-202-1R	1							
	TOP PLATE ASSEMBLY		1							
	BRACKET		1							
	BRACKET		1	X	X					
	WARNING LABEL		1							
	WARNING LABEL		1							
	STICKER		1							
7	POWER LEAD	R-5041-657-1R	1	X	X					
8	CONTROL PANEL COVER	T-8040-079-1R	1	X	X					

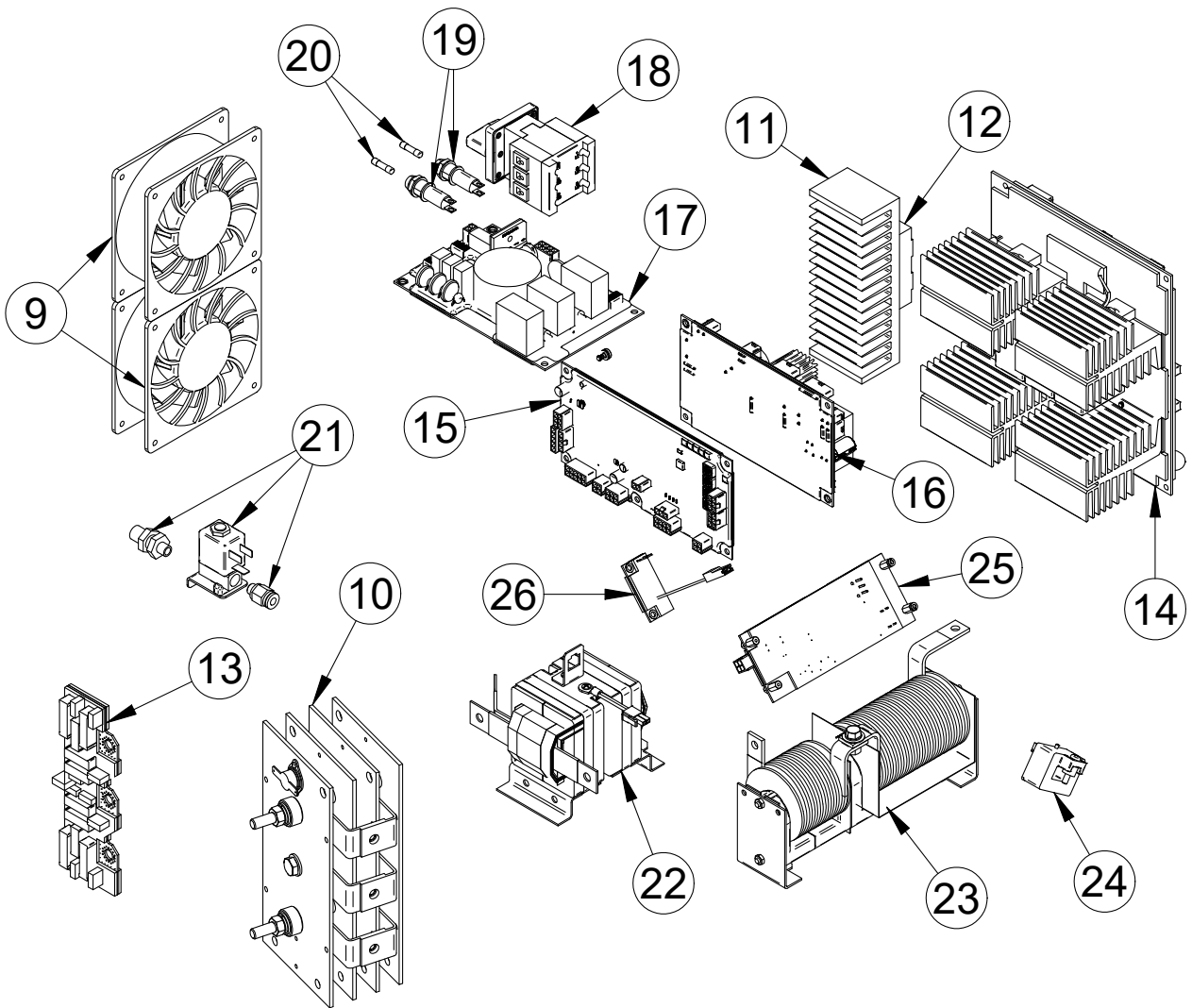

Figure B

Figure B: Inside Machine Assembly

Item	Description	Part Number	QTY	1	2	3	4	5	6	7
9	FAN	R-8040-433-1R	2	X	X					
10	OUTPUT BRIDGE	R-0000-364-1R	1	X	X					
11	HEATSINK	R-0000-047-1R	1	X	X					
12	INPUT RECTIFIER V1	W4100021R	1	X	X					
13	OUTPUT AND FILTER BOARD	Y087-1R	1	X	X					
14	UNIVERSAL SiC INVERTER - 400A	Y092-4R	1	X	X					
	<i>Y092-5R and Y092-6R are substitutes for Y092-4R</i>									
15	CONTROL BOARD	R-6042-105-1R	1	X	X					
16	AUXILIARY POWER SUPPLY BOARD	R-6042-129-1R	1	X	X					
17	INPUT EMI FILTER BOARD	Y074-2R	1	X	X					
18	SWITCH 3Ph 40A AND FLACEPLATE	W7511709R	1	X	X					
19	FUSE HOLDER IP67	1158-632-034R	2	X	X					
20	FUSE T5X20 2A 500VAC	1158-660-110R	2	X	X					
21	GAS CONNECTION KIT includes:	T-8040-203-1R	1	X	X					
	GAS SOLENOID 24VDC 50L/MIN		1							
	ELECTROVALVE BRACKET		1							
	BULKHEAD 1/4-1/8+NUT 1/4		1							
	HOSE CARRIER PU STRAIGHT		2							
	BRASS QUICK CONNECT COUPLING		1							
22	TRANSFORMER	R-4034-186-1R	1	X	X					
23	HF TRANSFORMER WITH CHOKE	R-0000-357-1R	1	X	X					
24	CURRENT SENSOR 4V 300A +/-15V	1157-769-157R	1	X	X					
25	HF BOARD	W05X1615-2R	1	X	X					
26	OUTPUT EMC-FILTER	Y097-3R	1	X	X					

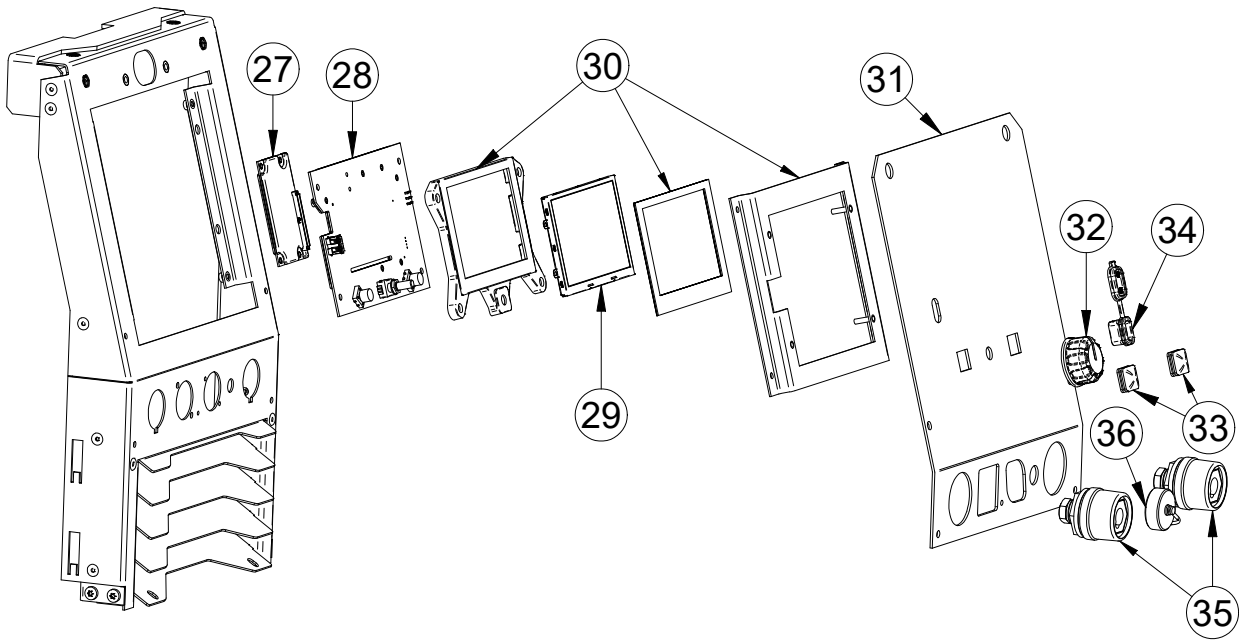

Figure C

Figure C: Front Assembly

Item	Description	Part Number	QTY	1	2	3	4	5	6	7
27	SoM BOARD	R-6042-109-1R	1	X	X					
28	TFT FRONT PANEL BOARD	R-6042-106-1R	1	X	X					
29	5 INCH TFT COLOR DISPLAY	0942-172-003R	1	X	X					
30	DISPLAY KIT includes:	T-8040-204-1R	1							
	SCREEN 5" BRACKET		1							
	DISPLAY FOAM		1	X	X					
	BRACKET		1							
31	FRONT PANEL	R-0000-367-1R	1	X	X					
32	KNOB, 1.5"	9SM22778-2	1	X	X					
33	BUTTON COVER	9SS23055	2	X	X					
34	USB CAP	R-0010-804-1R	1	X	X					
35	SOCKET X2, X3, X4	90000595PR	2	X	X					
36	PROTECTION COVER PLUG AMP	1158-641-128R	1	X	X					

Miscellaneous Items (not shown in figure A, B, C,)

Item	Description	Part Number	QTY	1	2	3	4	5	6	7
37	HARNESSES KIT	T-8040-205-1R	1	X	X					

Electrical Schematic

CODE: 50618, 50739

