

PRO 155

For use with machine Code Numbers **10023; 10024; 10025; 10134, 10208 and 10684**



This manual covers equipment which is no longer in production by The Lincoln Electric Co. Specifications and availability of optional features may have changed.

Safety Depends on You

Lincoln arc welding and cutting equipment is designed and built with safety in mind. However, your overall safety can be increased by proper installation ... and thoughtful operation on your part. **DO NOT INSTALL, OPERATE OR REPAIR THIS EQUIPMENT WITHOUT READING THIS MANUAL AND THE SAFETY PRECAUTIONS CONTAINED THROUGHOUT.** And, most importantly, think before you act and be careful.

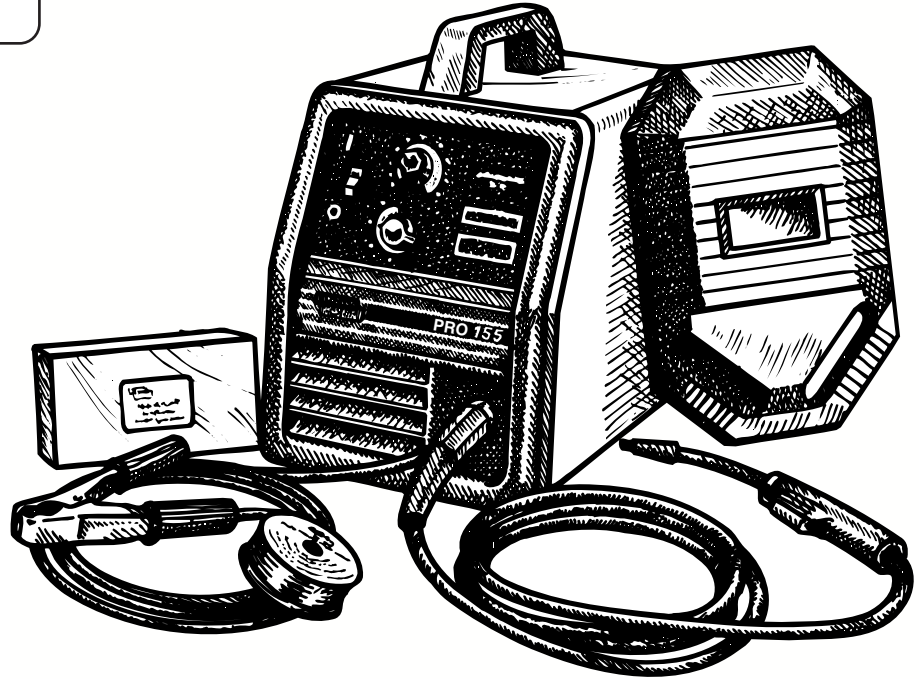

Date of Purchase: _____
 Serial Number: _____
 Code Number: _____
 Model: _____
 Where Purchased: _____

OPERATOR'S MANUAL



Copyright © 2001 Lincoln Global Inc.

• World's Leader in Welding and Cutting Products •
 • Sales and Service through Subsidiaries and Distributors Worldwide •
 Cleveland, Ohio 44117-1199 U.S.A. TEL: 216.481.8100 FAX: 216.486.1751 WEB SITE: www.lincolnelectric.com

⚠ WARNING



CALIFORNIA PROPOSITION 65 WARNINGS



Diesel engine exhaust and some of its constituents are known to the State of California to cause cancer, birth defects, and other reproductive harm.

The Above For Diesel Engines

The engine exhaust from this product contains chemicals known to the State of California to cause cancer, birth defects, or other reproductive harm.

The Above For Gasoline Engines

ARC WELDING CAN BE HAZARDOUS. PROTECT YOURSELF AND OTHERS FROM POSSIBLE SERIOUS INJURY OR DEATH. KEEP CHILDREN AWAY. PACEMAKER WEARERS SHOULD CONSULT WITH THEIR DOCTOR BEFORE OPERATING.

Read and understand the following safety highlights. For additional safety information, it is strongly recommended that you purchase a copy of "Safety in Welding & Cutting - ANSI Standard Z49.1" from the American Welding Society, P.O. Box 351040, Miami, Florida 33135 or CSA Standard W117.2-1974. A Free copy of "Arc Welding Safety" booklet E205 is available from the Lincoln Electric Company, 22801 St. Clair Avenue, Cleveland, Ohio 44117-1199.

BE SURE THAT ALL INSTALLATION, OPERATION, MAINTENANCE AND REPAIR PROCEDURES ARE PERFORMED ONLY BY QUALIFIED INDIVIDUALS.



FOR ENGINE powered equipment.

1.a. Turn the engine off before troubleshooting and maintenance work unless the maintenance work requires it to be running.



1.b. Operate engines in open, well-ventilated areas or vent the engine exhaust fumes outdoors.



1.c. Do not add the fuel near an open flame welding arc or when the engine is running. Stop the engine and allow it to cool before refueling to prevent spilled fuel from vaporizing on contact with hot engine parts and igniting. Do not spill fuel when filling tank. If fuel is spilled, wipe it up and do not start engine until fumes have been eliminated.



1.d. Keep all equipment safety guards, covers and devices in position and in good repair. Keep hands, hair, clothing and tools away from V-belts, gears, fans and all other moving parts when starting, operating or repairing equipment.

1.e. In some cases it may be necessary to remove safety guards to perform required maintenance. Remove guards only when necessary and replace them when the maintenance requiring their removal is complete. Always use the greatest care when working near moving parts.

1.f. Do not put your hands near the engine fan. Do not attempt to override the governor or idler by pushing on the throttle control rods while the engine is running.

1.g. To prevent accidentally starting gasoline engines while turning the engine or welding generator during maintenance work, disconnect the spark plug wires, distributor cap or magneto wire as appropriate.



1.h. To avoid scalding, do not remove the radiator pressure cap when the engine is hot.



ELECTRIC AND MAGNETIC FIELDS may be dangerous

2.a. Electric current flowing through any conductor causes localized Electric and Magnetic Fields (EMF). Welding current creates EMF fields around welding cables and welding machines

2.b. EMF fields may interfere with some pacemakers, and welders having a pacemaker should consult their physician before welding.

2.c. Exposure to EMF fields in welding may have other health effects which are now not known.

2.d. All welders should use the following procedures in order to minimize exposure to EMF fields from the welding circuit:

2.d.1. Route the electrode and work cables together - Secure them with tape when possible.

2.d.2. Never coil the electrode lead around your body.

2.d.3. Do not place your body between the electrode and work cables. If the electrode cable is on your right side, the work cable should also be on your right side.

2.d.4. Connect the work cable to the workpiece as close as possible to the area being welded.

2.d.5. Do not work next to welding power source.

Mar '95



ELECTRIC SHOCK can kill.

- 3.a. The electrode and work (or ground) circuits are electrically "hot" when the welder is on. Do not touch these "hot" parts with your bare skin or wet clothing. Wear dry, hole-free gloves to insulate hands.
- 3.b. Insulate yourself from work and ground using dry insulation. Make certain the insulation is large enough to cover your full area of physical contact with work and ground.
- In addition to the normal safety precautions, if welding must be performed under electrically hazardous conditions (in damp locations or while wearing wet clothing; on metal structures such as floors, gratings or scaffolds; when in cramped positions such as sitting, kneeling or lying, if there is a high risk of unavoidable or accidental contact with the workpiece or ground) use the following equipment:**
- Semiautomatic DC Constant Voltage (Wire) Welder.
 - DC Manual (Stick) Welder.
 - AC Welder with Reduced Voltage Control.
- 3.c. In semiautomatic or automatic wire welding, the electrode, electrode reel, welding head, nozzle or semiautomatic welding gun are also electrically "hot".
- 3.d. Always be sure the work cable makes a good electrical connection with the metal being welded. The connection should be as close as possible to the area being welded.
- 3.e. Ground the work or metal to be welded to a good electrical (earth) ground.
- 3.f. Maintain the electrode holder, work clamp, welding cable and welding machine in good, safe operating condition. Replace damaged insulation.
- 3.g. Never dip the electrode in water for cooling.
- 3.h. Never simultaneously touch electrically "hot" parts of electrode holders connected to two welders because voltage between the two can be the total of the open circuit voltage of both welders.
- 3.i. When working above floor level, use a safety belt to protect yourself from a fall should you get a shock.
- 3.j. Also see Items 6.c. and 8.



ARC RAYS can burn.

- 4.a. Use a shield with the proper filter and cover plates to protect your eyes from sparks and the rays of the arc when welding or observing open arc welding. Headshield and filter lens should conform to ANSI Z87.1 standards.
- 4.b. Use suitable clothing made from durable flame-resistant material to protect your skin and that of your helpers from the arc rays.
- 4.c. Protect other nearby personnel with suitable, non-flammable screening and/or warn them not to watch the arc nor expose themselves to the arc rays or to hot spatter or metal.



FUMES AND GASES can be dangerous.

- 5.a. Welding may produce fumes and gases hazardous to health. Avoid breathing these fumes and gases. When welding, keep your head out of the fume. Use enough ventilation and/or exhaust at the arc to keep fumes and gases away from the breathing zone. **When welding with electrodes which require special ventilation such as stainless or hard facing (see instructions on container or MSDS) or on lead or cadmium plated steel and other metals or coatings which produce highly toxic fumes, keep exposure as low as possible and below Threshold Limit Values (TLV) using local exhaust or mechanical ventilation. In confined spaces or in some circumstances, outdoors, a respirator may be required. Additional precautions are also required when welding on galvanized steel.**
- 5.b. Do not weld in locations near chlorinated hydrocarbon vapors coming from degreasing, cleaning or spraying operations. The heat and rays of the arc can react with solvent vapors to form phosgene, a highly toxic gas, and other irritating products.
- 5.c. Shielding gases used for arc welding can displace air and cause injury or death. Always use enough ventilation, especially in confined areas, to insure breathing air is safe.
- 5.d. Read and understand the manufacturer's instructions for this equipment and the consumables to be used, including the material safety data sheet (MSDS) and follow your employer's safety practices. MSDS forms are available from your welding distributor or from the manufacturer.
- 5.e. Also see item 1.b.

Mar '95

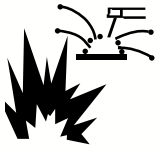

WELDING SPARKS can cause fire or explosion.

6.a. Remove fire hazards from the welding area.

If this is not possible, cover them to prevent the welding sparks from starting a fire.

Remember that welding sparks and hot materials from welding can easily go through small cracks and openings to adjacent areas. Avoid welding near hydraulic lines. Have a fire extinguisher readily available.

- 6.b. Where compressed gases are to be used at the job site, special precautions should be used to prevent hazardous situations. Refer to "Safety in Welding and Cutting" (ANSI Standard Z49.1) and the operating information for the equipment being used.
- 6.c. When not welding, make certain no part of the electrode circuit is touching the work or ground. Accidental contact can cause overheating and create a fire hazard.
- 6.d. Do not heat, cut or weld tanks, drums or containers until the proper steps have been taken to insure that such procedures will not cause flammable or toxic vapors from substances inside. They can cause an explosion even though they have been "cleaned". For information, purchase "Recommended Safe Practices for the Preparation for Welding and Cutting of Containers and Piping That Have Held Hazardous Substances", AWS F4.1 from the American Welding Society (see address above).
- 6.e. Vent hollow castings or containers before heating, cutting or welding. They may explode.
- 6.f. Sparks and spatter are thrown from the welding arc. Wear oil free protective garments such as leather gloves, heavy shirt, cuffless trousers, high shoes and a cap over your hair. Wear ear plugs when welding out of position or in confined places. Always wear safety glasses with side shields when in a welding area.
- 6.g. Connect the work cable to the work as close to the welding area as practical. Work cables connected to the building framework or other locations away from the welding area increase the possibility of the welding current passing through lifting chains, crane cables or other alternate circuits. This can create fire hazards or overheat lifting chains or cables until they fail.
- 6.h. Also see item 1.c.

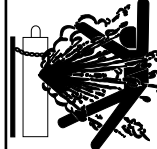

CYLINDER may explode if damaged.

- 7.a. Use only compressed gas cylinders containing the correct shielding gas for the process used and properly operating regulators designed for the gas and pressure used. All hoses, fittings, etc. should be suitable for the application and maintained in good condition.
- 7.b. Always keep cylinders in an upright position securely chained to an undercarriage or fixed support.
- 7.c. Cylinders should be located:
 - Away from areas where they may be struck or subjected to physical damage.
 - A safe distance from arc welding or cutting operations and any other source of heat, sparks, or flame.
- 7.d. Never allow the electrode, electrode holder or any other electrically "hot" parts to touch a cylinder.
- 7.e. Keep your head and face away from the cylinder valve outlet when opening the cylinder valve.
- 7.f. Valve protection caps should always be in place and hand tight except when the cylinder is in use or connected for use.
- 7.g. Read and follow the instructions on compressed gas cylinders, associated equipment, and CGA publication P-1, "Precautions for Safe Handling of Compressed Gases in Cylinders," available from the Compressed Gas Association 1235 Jefferson Davis Highway, Arlington, VA 22202.



FOR ELECTRICALLY powered equipment.

- 8.a. Turn off input power using the disconnect switch at the fuse box before working on the equipment.
- 8.b. Install equipment in accordance with the U.S. National Electrical Code, all local codes and the manufacturer's recommendations.
- 8.c. Ground the equipment in accordance with the U.S. National Electrical Code and the manufacturer's recommendations.

Mar '95

PRÉCAUTIONS DE SÛRETÉ

Pour votre propre protection lire et observer toutes les instructions et les précautions de sûreté spécifiques qui paraissent dans ce manuel aussi bien que les précautions de sûreté générales suivantes:

Sûreté Pour Soudage A L'Arc

1. Protégez-vous contre la secousse électrique:
 - a. Les circuits à l'électrode et à la pièce sont sous tension quand la machine à souder est en marche. Eviter toujours tout contact entre les parties sous tension et la peau nue ou les vêtements mouillés. Porter des gants secs et sans trous pour isoler les mains.
 - b. Faire très attention de bien s'isoler de la masse quand on soude dans des endroits humides, ou sur un plancher métallique ou des grilles métalliques, principalement dans les positions assis ou couché pour lesquelles une grande partie du corps peut être en contact avec la masse.
 - c. Maintenir le porte-électrode, la pince de masse, le câble de soudage et la machine à souder en bon et sûr état de fonctionnement.
 - d. Ne jamais plonger le porte-électrode dans l'eau pour le refroidir.
 - e. Ne jamais toucher simultanément les parties sous tension des porte-électrodes connectés à deux machines à souder parce que la tension entre les deux pinces peut être le total de la tension à vide des deux machines.
 - f. Si on utilise la machine à souder comme une source de courant pour soudage semi-automatique, ces précautions pour le porte-électrode s'appliquent aussi au pistolet de soudage.
2. Dans le cas de travail au dessus du niveau du sol, se protéger contre les chutes dans le cas où on recoit un choc. Ne jamais enrouler le câble-électrode autour de n'importe quelle partie du corps.
3. Un coup d'arc peut être plus sévère qu'un coup de soleil, donc:
 - a. Utiliser un bon masque avec un verre filtrant approprié ainsi qu'un verre blanc afin de se protéger les yeux du rayonnement de l'arc et des projections quand on soude ou quand on regarde l'arc.
 - b. Porter des vêtements convenables afin de protéger la peau de soudeur et des aides contre le rayonnement de l'arc.
 - c. Protéger l'autre personnel travaillant à proximité au soudage à l'aide d'écrans appropriés et non-inflammables.
4. Des gouttes de laitier en fusion sont émises de l'arc de soudage. Se protéger avec des vêtements de protection libres de l'huile, tels que les gants en cuir, chemise épaisse, pantalons sans revers, et chaussures montantes.

5. Toujours porter des lunettes de sécurité dans la zone de soudage. Utiliser des lunettes avec écrans latéraux dans les zones où l'on pique le laitier.
6. Eloigner les matériaux inflammables ou les recouvrir afin de prévenir tout risque d'incendie dû aux étincelles.
7. Quand on ne soude pas, poser la pince à un endroit isolé de la masse. Un court-circuit accidentel peut provoquer un échauffement et un risque d'incendie.
8. S'assurer que la masse est connectée le plus près possible de la zone de travail qu'il est pratique de le faire. Si on place la masse sur la charpente de la construction ou d'autres endroits éloignés de la zone de travail, on augmente le risque de voir passer le courant de soudage par les chaînes de levage, câbles de grue, ou autres circuits. Cela peut provoquer des risques d'incendie ou d'échauffement des chaînes et des câbles jusqu'à ce qu'ils se rompent.
9. Assurer une ventilation suffisante dans la zone de soudage. Ceci est particulièrement important pour le soudage de tôles galvanisées plombées, ou cadmiées ou tout autre métal qui produit des fumées toxiques.
10. Ne pas souder en présence de vapeurs de chlore provenant d'opérations de dégraissage, nettoyage ou pistolage. La chaleur ou les rayons de l'arc peuvent réagir avec les vapeurs du solvant pour produire du phosgène (gas fortement toxique) ou autres produits irritants.
11. Pour obtenir de plus amples renseignements sur la sûreté, voir le code "Code for safety in welding and cutting" CSA Standard W 117.2-1974.

PRÉCAUTIONS DE SÛRETÉ POUR LES MACHINES À SOUDER À TRANSFORMATEUR ET À REDRESSEUR

1. Relier à la terre le châssis du poste conformément au code de l'électricité et aux recommandations du fabricant. Le dispositif de montage ou la pièce à souder doit être branché à une bonne mise à la terre.
2. Autant que possible, l'installation et l'entretien du poste seront effectués par un électricien qualifié.
3. Avant de faire des travaux à l'intérieur de poste, la débrancher à l'interrupteur à la boîte de fusibles.
4. Garder tous les couvercles et dispositifs de sûreté à leur place.

Thank You

for selecting a **QUALITY** product by Lincoln Electric. We want you to take pride in operating this Lincoln Electric Company product
•• as much pride as we have in bringing this product to you!

Please Examine Carton and Equipment For Damage Immediately

When this equipment is shipped, title passes to the purchaser upon receipt by the carrier. Consequently, Claims for material damaged in shipment must be made by the purchaser against the transportation company at the time the shipment is received.

Please record your equipment identification information below for future reference. This information can be found on your machine nameplate.

Model Name & Number _____

Code & Serial Number _____

Date of Purchase _____

Whenever you request replacement parts for or information on this equipment always supply the information you have recorded above.

Read this Operators Manual completely before attempting to use this equipment. Save this manual and keep it handy for quick reference. Pay particular attention to the safety instructions we have provided for your protection. The level of seriousness to be applied to each is explained below:

⚠ WARNING

This statement appears where the information **must** be followed **exactly** to avoid **serious personal injury** or **loss of life**.

⚠ CAUTION

This statement appears where the information **must** be followed to avoid **minor personal injury** or **damage to this equipment**.

MASTER TABLE OF CONTENTS FOR ALL SECTIONS

	Page
Installation	Section A
Technical Specifications	A-1
Safety Precautions.....	A-2
Identify and Locate Components	A-2
Select Suitable Location	A-3
Output Connections	A-3
Gun Installation.....	A-4
Gas Connection (Optional)	A-5
Electrical Input Connections.....	A-6
Line Cord Connection	A-6
Operation	Section B
Safety Precautions	B-1
General Description	B-2
Design Features and Advantages.....	B-2
Welding Capability	B-2
Limitations	B-2
Controls and Settings.....	B-2
Welding Operations	B-3
Overload Protection	B-6
Learning to Weld.....	B-7
Proper Gun Handling.....	B-17
Application Chart	B-18
Accessories	Section C
Accessories	C-1
Mig Conversion.....	C-1
Maintenance	Section D
Safety Precautions	D-1
Routine Maintenance.....	D-1
Gun and Cable Maintenance.....	D-2
Component Replacement Procedures	D-2
Changing Drive Roll	D-3
Changing Liner	D-4
Gun Handle Parts.....	D-4
Troubleshooting	Section E
How to Use Troubleshooting Guide.....	E-1
Troubleshooting Guide.....	E-2 thru E-4
Wiring Diagrams	Section F
PRO 155 Wiring Diagram	F-1
PRO 155 Parts Manual.....	P262, P202E Series

TECHNICAL SPECIFICATIONS – PRO 155

INPUT – SINGLE PHASE ONLY			
<u>Standard Voltage/Frequency</u> 230V/60Hz 208V/60Hz		<u>Input Current</u> 20 Amps - Rated Output 22 Amps - Rated output	
RATED OUTPUT			
<u>Input Voltage</u> 230V 208V	<u>Duty Cycle</u> 30% 25%	<u>Amps</u> 130 130	<u>Volts at Rated Amps</u> 20 20
OUTPUT			
<u>Welding Current Range</u> Rated DC Output: 30 - 155 amps		<u>Maximum Open Circuit Voltage</u> 33	<u>Wire Speed Range</u> 50-400 IPM (1.3-10.2 m/min)

RECOMMENDED INPUT CABLE AND FUSE SIZES					
Input Voltage	Fuse or Breaker Size	Input Amps	Power Cord	Type 75°C Wire in Conduit, Copper Cond. AWG Size	Grounding Wire Copper Cond. AWG Size
208V/60Hz	40 Amp	22	50 Amp, 250V, Three Prong Plug (NEMA Type 6-50P)	8 AWG	10
230V/60Hz	40 Amp	20	50 Amp, 250V, Three Prong Plug (NEMA Type 6-50P)	8 AWG	10

PHYSICAL DIMENSIONS			
Height	Width	Depth	Weight
12.0 in 305 mm	9.75 in 248 mm	16.5 in 419 mm	57 lbs 25.9 kg

Read entire installation section before starting installation.

SAFETY PRECAUTIONS

⚠ WARNING



ELECTRIC SHOCK can kill.

- Only qualified personnel should perform this installation.
- Only personnel that have read and understood the PRO 155 Operating Manual should install and operate this equipment.
- Machine must be plugged into a receptacle which is grounded per any national, local or other applicable electrical codes.
- The PRO 155 power switch is to be in the OFF ("O") position when installing work cable and gun and when connecting power cord to input power.

IDENTIFY AND LOCATE COMPONENTS

If you have not already done so, unpack the PRO 155 from its carton and remove all packing material around the PRO 155. Remove the following loose items from the carton (see Figure A.1):

1. PRO 155
2. Gun and cable assembly⁽¹⁾
3. Literature and miscellaneous including:
 - a) This operating manual
 - b) 10 extra .045" contact tips
 - c) Hex key wrench for removal of drive roll.
4. 10 ft (3,0 m) work cable.
5. Work clamp.
6. Sample 10 lb. spool of Innershield .045" (1.2 mm) NR-211-MP electrode.
7. Handshield with filter plate and lens.
8. Instructional video.
9. 8" Spool Adapter (2" Spindle) for mounting 10 lb. Spools. (May be installed)

For available options and accessories refer to accessories section.

⁽¹⁾The gun is ready to feed 0.045" (1.2 mm) Innershield wire.

FIGURE A.1

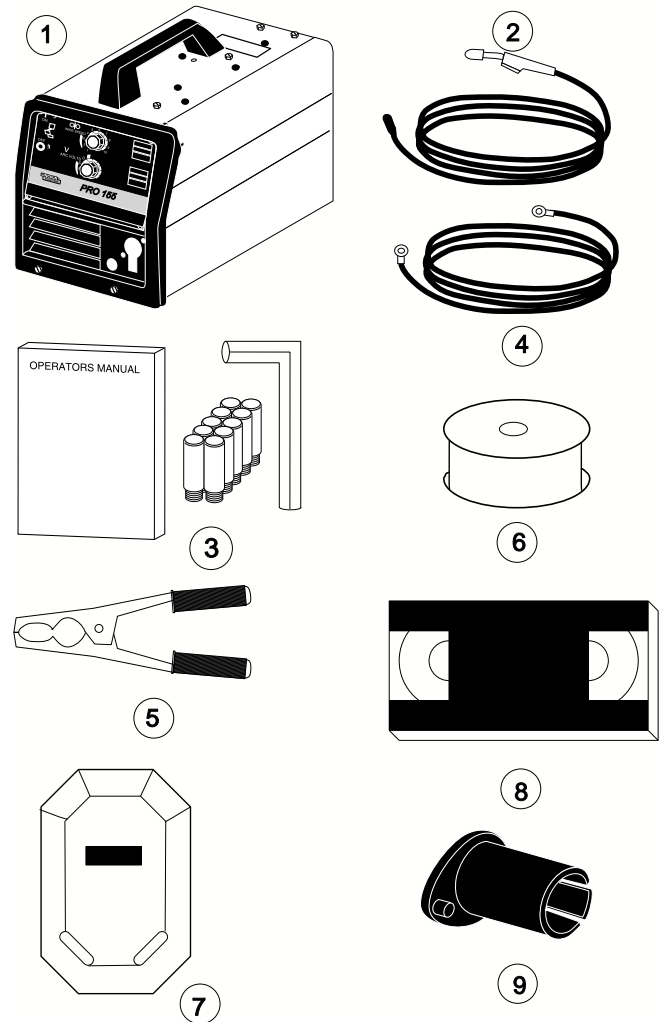

SELECT SUITABLE LOCATION

Locate the welder in a dry location where there is free circulation of clean air into the louvers in the back and out the front of the unit. A location that minimizes the amount of smoke and dirt drawn into the rear louvers reduces the chance of dirt accumulation that can block air passages and cause overheating.

STACKING

PRO 155's cannot be stacked.

TILTING

Each machine must be placed on a secure, level surface, either directly or on the recommended utility cart. The machine may topple over if this procedure is not followed.

OUTPUT CONNECTIONS

Refer to Figure A.2.

1. Work Cable Access Hole.
2. Gun Cable and Control Lead Access Hole.
3. Connector Block.
4. Gun Trigger Lead Connectors.
5. Positive (+) and negative (-) output terminals.

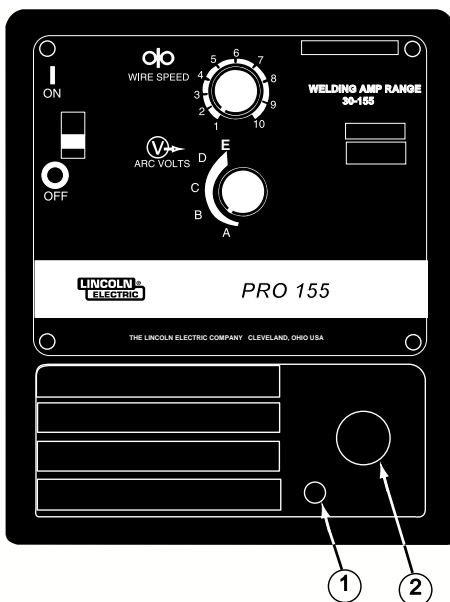

Work Clamp Installation

Attach the work clamp per the following: Refer to Figure A-3.

FIGURE A.3

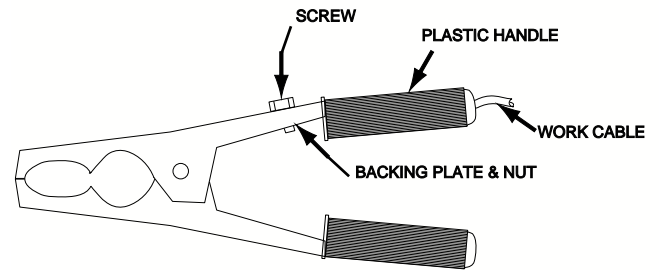

1. Remove the screw, pressure plate and backing nut from clamp.
2. Remove plastic handle from same side of clamp by pulling steadily on handle until it slides off clamp.
3. Insert the work cable terminal lug with the larger hole through the hole in the end of the plastic handle. Slide plastic handle several inches further onto cable to allow easy and clear access to terminal lug.
4. Secure work cable to clamp by inserting screw through hole in clamp, attaching cable lug on inside of clamp, and installing pressure plate and backing nut. make sure pressure plate is installed such that it prevents nut from turning. tighten screw securely.
5. Slide plastic handle back onto clamp and into original position.

FIGURE A.2

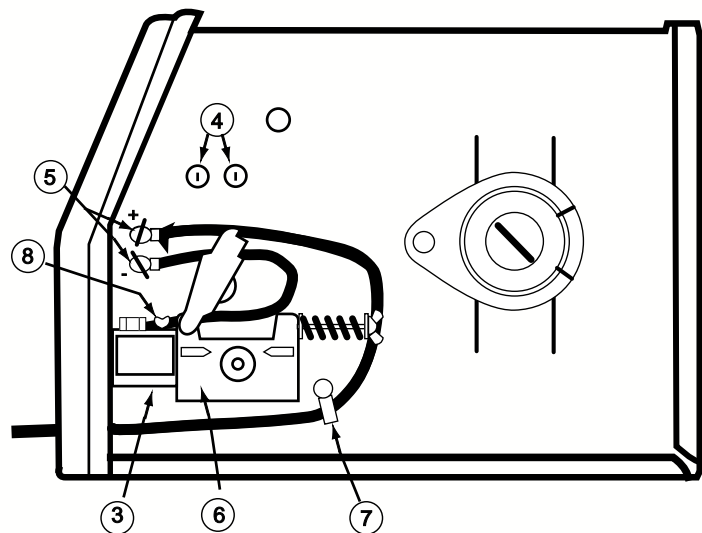

Work Cable Installation

Refer to Figure A.2.

1. Open the wire feed section door on the right side of the PRO 155.
2. Pass the end of the work cable that has the terminal lug with the smaller hole through the Work Cable Access Hole (1) in the case front.
3. Route the cable under and around the back of the Wire Feed Gearbox (6).
4. **For Innershield Only: Refer to Figure A.2.** As delivered, the PRO 155 is connected for negative electrode polarity. This is the appropriate configuration for the Innershield process. To complete installation, use the provided wing nut to connect the work cable's terminal lug to the positive (+) output terminal (5) located above the Wire Feed Gearbox (6). Make sure that both wing nuts are tight.
5. **For GMAW Only: Refer to Figure A.4.** To wire for positive polarity (required for the MIG process), connect the short cable attached to the connector block (1) to the positive (+) output terminal (4) and the work cable (3) to the negative (-) terminal (2).

FIGURE A.4

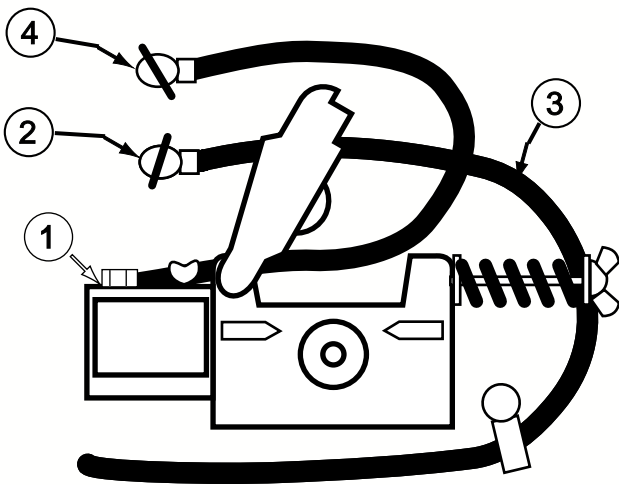

GUN INSTALLATION

As shipped from the factory, the PRO 155 gun is ready to feed 0.045" (1.2 mm) wire. If .023" – .025" (0.6 mm) or .030" (0.8 mm) wire is to be used for the GMAW (MIG) process, change the contact tip to the appropriate size and install a gas nozzle included with the K610-2 MIG Conversion kit. Additionally, the .023 – .030" (0.6 – 0.8

mm) gun liner included in the K610-2 MIG Conversion Kit must be installed. Also a KP665-035 drive roll must be used. This drive roll is not part of the K610-2 kit and must be ordered separately. Refer to the MAINTENANCE section for contact tip and drive roll installation details.

Connecting Gun Cable to the PRO 155

1. Refer to Figure A.2. Unplug the machine or turn power switch to the OFF "O" position.
2. Pass the insulated terminals of the gun trigger control leads, one at a time, through the Gun Cable and Control Lead Access Slot (2) in the case front. The leads are to be routed up the inside of the case front and behind the gas line.
3. Insert the connector on the gun conductor cable through the Gun Cable Access Hole (2) in the PRO 155 case front. Make sure the connector is all the way in the brass connector block. Unscrew thumbscrew on the connector block a few turns if gun connector will not insert fully. Rotate the connector so control leads are on the underside and tighten the Thumbscrew (8) in the connector block.
4. Connect the gun trigger control lead terminals to the two insulated 1/4" (6.4 mm) tab terminal connector bushings located above the "Gun Trigger Connection" decal in the wire feed section (4). Either lead can go to either connector. Form the leads so that they are as close as possible to the inside panel.

CAUTION

If the gun trigger switch being used is other than that supplied with the PRO 155, the switch must be a normally open, momentary switch. The terminals of the switch must be insulated from the welding circuit. Malfunction of the PRO 155 may result if this switch shorts to the PRO 155 welding output circuit or is common to any electrical circuit other than the PRO 155 trigger circuit.

GAS CONNECTION (OPTIONAL)

When using the GMAW process, a K610-2 MIG conversion kit and a cylinder of carbon dioxide (CO₂) or argon-carbon dioxide mixed shielding gas must be obtained. For more information about the K610-2 MIG Conversion Kit for use with the PRO 155, refer to the ACCESSORIES section.

⚠ WARNING



CYLINDER may explode if damaged. Keep cylinder upright and chained to support

- Keep cylinder away from areas where it may be damaged.
- Never lift welder with cylinder attached.
- Never allow welding electrode to touch cylinder.
- Keep cylinder away from welding or other live electrical circuits.

⚠ WARNING



BUILDUP OF SHIELDING GAS may harm health or kill.

- Shut off shielding gas supply when not in use.
- SEE AMERICAN NATIONAL STANDARD Z-49.1, "SAFETY IN WELDING AND CUTTING" PUBLISHED BY THE AMERICAN WELDING SOCIETY.

1. Chain the cylinder to a wall or other stationary support to prevent the cylinder from falling over. Insulate the cylinder from the work circuit and earth ground. Refer to Figure A.5.

FIGURE A.5

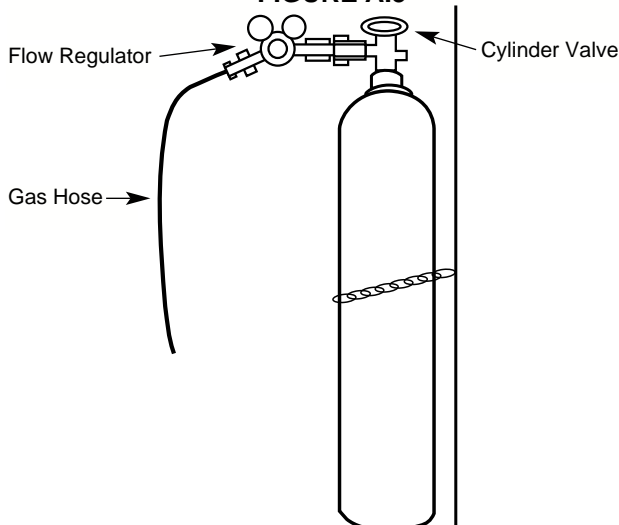

2. With the cylinder securely installed, remove the cylinder cap. Stand to one side away from the outlet and open the cylinder valve very slightly for an instant. This blows away any dust or dirt which may have accumulated in the valve outlet.

⚠ WARNING

BE SURE TO KEEP YOUR FACE AWAY FROM THE VALVE OUTLET WHEN "CRACKING" THE VALVE. Never stand directly in front of or behind the flow regulator when opening the cylinder valve. Always stand to one side.

3. Attach the flow regulator to the cylinder valve and tighten the union nut securely with a wrench..

NOTE: If connecting to 100% CO₂ cylinder, insert regulator adapter (provided with MIG Conversion Kit for the PRO 155) between regulator and cylinder valve. If adapter is equipped with a plastic washer, be sure it is seated for connection to the CO₂ cylinder.

4. Refer to Figure A.6. Attach one end of inlet gas hose to the outlet fitting of the flow regulator and tighten the union nut securely with a wrench. Connect the other end to the PRO 155 Gas Solenoid Inlet Fitting (5/8-18 female threads — for CGA — 032 fitting). Make certain the gas hose is not kinked or twisted.

ELECTRICAL INPUT CONNECTIONS

FIGURE A.6

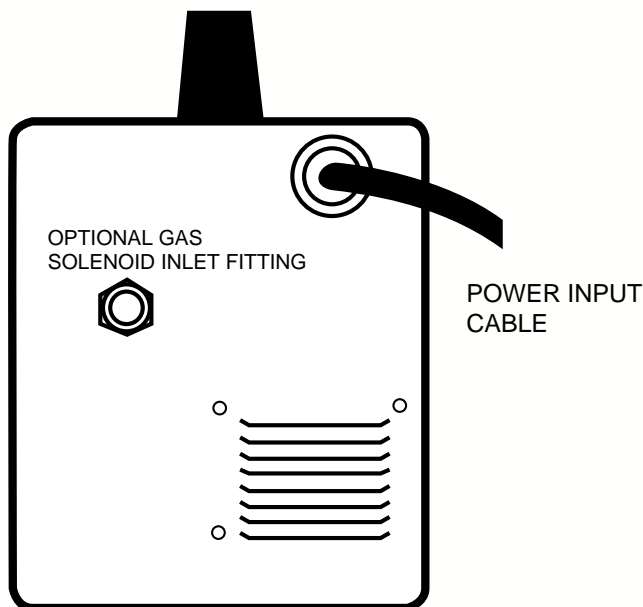

230 VOLT INPUT CONNECTIONS

The PRO 155 is shipped from the factory connected for 230 volt input power. If the welder has been reconnected for 208 volt input power and 230 volt input is desired, perform the following reconnection instructions:

⚠ WARNING

Make certain that the input power is electrically disconnected before removing the screws that hold the case side in place.

1. Disconnect welder from input power and remove case side panel.
2. Remove lead marked "H3" from CR1 on the control P.C. Board.
3. Remove tape securing H1 lead to lead sleeving and connect H1 to CR1.
4. Insulate unused H3 lead for 300 volts with electrical tape and secure to lead sleeving.
5. Reinstall case side before connecting input power.

208 VOLT INPUT CONNECTION

To connect the PRO 155 for 208 volt input power, perform the following reconnect instructions (which are

also included on the wiring diagram located on the inside of the case side panel):

1. Disconnect welder from input power and remove case side.
2. Remove lead marked "H1" from CR1 on the control P.C. Board.
3. Remove tape securing H3 to lead sleeving and connect H3 to CR1.
4. Insulate unused H1 lead for 300V with electrical tape and secure to lead sleeving.
5. Reinstall case side before connecting input power.

LINE CORD CONNECTION

⚠ WARNING

This welding machine must be connected to power source in accordance with applicable electrical codes.

The United States National Electrical Code (Article 630-B, 1990 Edition) provides standards for amperage handling capability of supply conductors based on duty cycle of the welding source.

If there is any question about the installation meeting applicable electrical code requirements, consult a qualified electrician.

A 12/3 AWG (3.3 mm²) 3 conductor line cord with a 50 amp, 250 volt, three-prong plug (NEMA Type 6-50P) is factory installed. Connect this plug to a mating grounded receptacle which is connected to an appropriate power supply per the U.S. National Electric Code and any applicable local codes. Refer to "Technical Specifications" for proper fuse and supply conductor sizes.

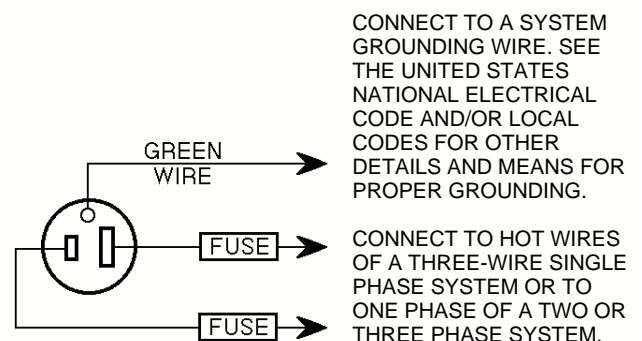

Read entire operation section before operating the PRO 155.

 **WARNING**



ELECTRIC SHOCK can kill.

- Do not touch electrically live parts or electrode with skin or wet clothing. Insulate yourself from work and ground.
- Always wear dry insulating gloves.



FUMES AND GASES can be dangerous.

- Keep your head out of fumes.
- Use ventilation or exhaust to remove fumes from breathing zone.

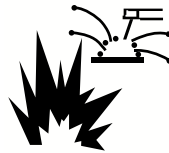

WELDING SPARKS can cause fire or explosion.

- Keep flammable material away.
- Do not weld on closed containers.



ARC RAYS can burn eyes and skin.

- Wear eye, ear and body protection.

Observe all safety information throughout this manual.

GENERAL DESCRIPTION

The PRO 155 is a compact lightweight DC wire feeder/power source. It has been designed for workshop, hobby, and light maintenance. It is capable of general purpose welding with self-shielded flux-cored (Innershield®) wire. When combined with the optional K610-2 MIG Conversion Kit, the PRO 155 is suitable for GMAW (MIG) welding applications.

The PRO 155 operates on 208/230 volt 60 Hz AC input power. It is ideally suited for individuals wanting the ease of use, quality and dependability of both gas metal arc welding or GMAW (also known as MIG welding) and the Innershield electrode process (self shielded flux cored or FCAW). The PRO 155 is a rugged and reliable machine that has been designed for dependable service and long life.

RECOMMENDED PROCESSES

The PRO 155 can be used for welding mild steel using the self shielded, Innershield electrode process (FCAW) or it can be used for the GMAW, single pass, process which requires a supply of shielding gas and the K610-2 MIG Conversion Kit. The PRO 155 is configured for use with the FCAW process as delivered from the factory.

OPERATIONAL FEATURES AND CONTROLS

The PRO 155 has the following controls as standard: Power ON/OFF Switch, Voltage Control, Wire Speed Control, Trigger Switch, and a Circuit Breaker.

DESIGN FEATURES AND ADVANTAGES

- Compact — portable.
- “Cold electrode” until gun trigger is pressed for an added measure of safety.
- Overload protection — incorporates both a thermostat and a circuit breaker.
- Quality wire drive with electronic overload protection.
- “Quick Release” idle roll pressure arm is easily adjusted.
- Reversible, dual groove drive roll. Drive roll will feed .045” (1.2 mm) diameter wire.

- No external shielding gas is required when used with Lincoln Innershield .045” (1.2 mm) NR®-211-MP electrode.
- Accommodates 4” (100 mm) diameter spool of wire. Will accommodate 8” (200 mm) diameter with optional spindle.

WELDING CAPABILITY

The PRO 155 is rated at 130 amps, 20 volts, at 20% duty cycle on a ten minute basis when connected to 208V input. With a 230V input connection the rated output is 130 amps at 20 volts at 30% duty cycle. It is capable of higher output currents at lower duty cycles.

LIMITATIONS

Arc Gouging cannot be performed with the PRO 155. The PRO 155 is not recommended for pipe thawing or TIG welding.

CONTROLS AND SETTINGS

Refer to Figure B.1a.

1. Power ON/OFF Switch — When the power is on the fan motor will run and air will be exhausted out the louvers in the front of the machine. The welding output and wire feeder remain off until the gun trigger is pressed.
2. Voltage Control — A 5-position tap selector switch gives full range adjustment of power source output voltage. Do not switch while welding.
3. Wire Speed Control — Controls the wire feed speed from 50 – 400 in /min (1.3 – 10.2 m/min). The control can be preset on the dial to the setting specified on the PRO 155 Application Chart located on the inside of the wire feed section door.



OFF

—



ARC VOLTS



WIRE SPEED

Refer to Figure B-1b.

4. Circuit Breaker – Protects machine from damage if maximum output is exceeded. Button will extend out when tripped (Manual reset).

FIGURE B.1a

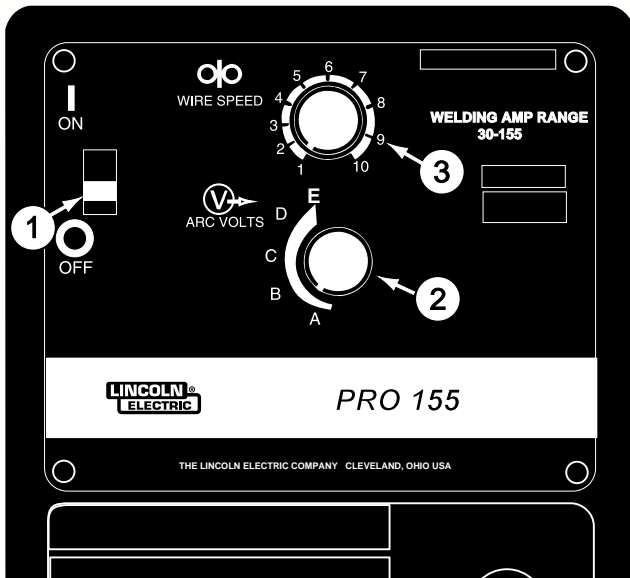
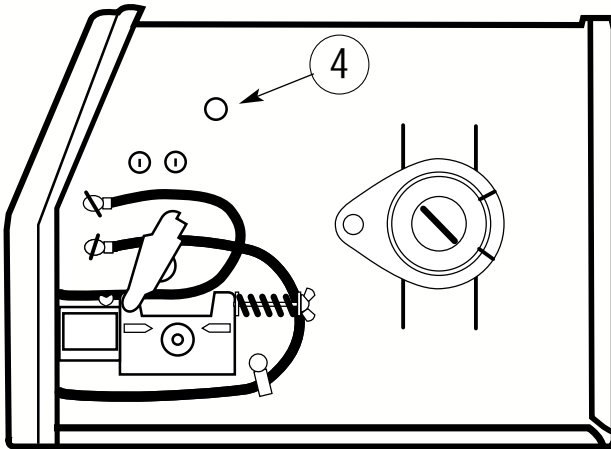

FIGURE B.1b



WELDING OPERATIONS

SEQUENCE OF OPERATION

Wire Loading

Refer to Figure B.2 and B.3.

The machine power switch should be turned to the OFF ("O") position before working inside the wire feed enclosure.

The machine is shipped from the factory ready to feed 8" (200 mm) diameter spools [2.2" (56 mm) max. width]. These spools fit on a 2" (50 mm) diameter spindle that has a built-in adjustable friction brake to prevent overrun of the spool and excess slack in the wire.

Note: When loading and removing the 8" Spools make sure that the wing nut (inside the wire spool spindle hub) is turned 90° from the wire spool spindle locking tab. If the wing nut is positioned in line with the locking tab, the tab cannot be depressed to load or unload the wire spool.

FIGURE B.2

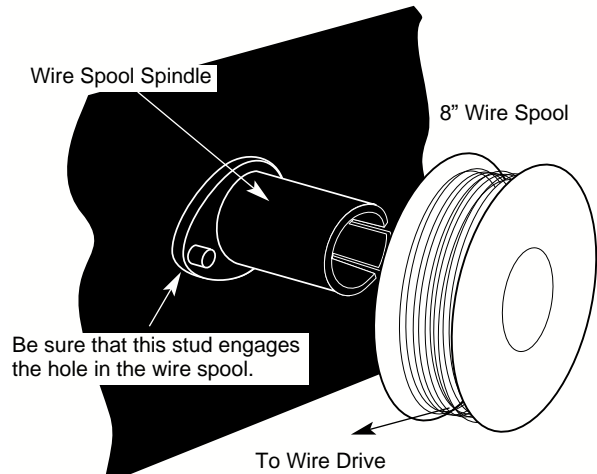

Wire Spool must be pushed all the way on the spindle so that the spindle's tab will hold it in place. The Wire Spool will rotate clockwise when wire is dereeled.

Load an 8" (200 mm) diameter spool on the wire spool spindle shown in Figure B.2.

To use 4" (100 mm) diameter spools, the 2" (50 mm) diameter spindle must be removed (See Figure B.3). Remove the wing nut and spacer at the end of the shaft and remove the outside plastic wire spool spindle. The spindle can be stored in the wire feed compartment. A 4" (100 mm) diameter spool is mounted directly on the 5/8" (16 mm) diameter shaft and held in place with the previously removed hardware. Also make certain the start end of the wire, which may protrude through the side of the spool does not contact any metallic case parts.

FIGURE B.3

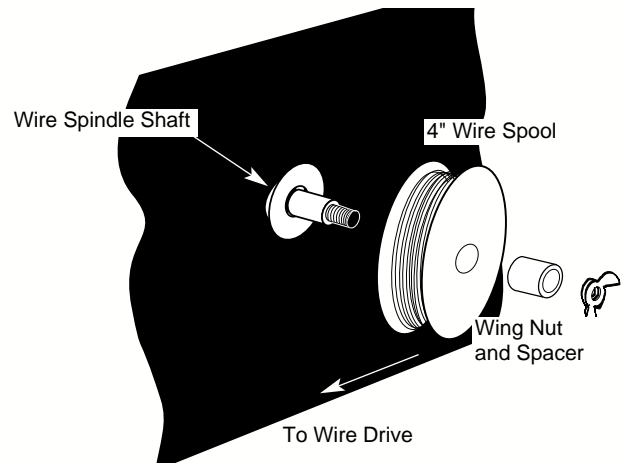

PRO 155

LINCOLN
ELECTRIC

Friction Brake Adjustment

With wire spool installed on the spindle shaft and the wing nut loose, turn the spool by hand while slowly tightening the wing nut until a light drag is felt. Tighten the wing nut an additional 1/4 turn.

Note: When properly adjusted, the brake should provide only enough drag to prevent overrun of the spool and excess slack in the wire. Too much drag may result in wire feeding problems, and may cause premature wear of wire drive system components.

Wire Threading

Refer to Figure B-4

1. Release the Spring Loaded Pressure Arm (1) rotate the Idle Roll Arm (2) away from the Wire Feed Drive Roll (3). Ensure that the groove size in the feeding position on the drive roll matches the wire size being used.
2. Carefully detach the end of the wire from the spool. To prevent the spool from unwinding, maintain tension on the wire until after step 5.
3. Cut the bent portion of wire off and straighten the first 4" (100 mm).
4. Thread the wire through the In-going guide tube (4), over the drive roll (3), and into the out-going guide tube (5).
5. Close the idle roll arm (2) and latch the spring loaded pressure arm (1) in place. Rotate the spool counterclockwise if required in order to take up extra slack in the wire.
6. The idle roll pressure adjustment wing nut is factory set to approximately five full turns from where the wing nut first engages the threads of the pressure arm (1). If feeding problems occur because the wire is flattened excessively, turn the pressure adjustment counter-clockwise to reduce distortion of the wire. Slightly less pressure may be required when using 0.023 – 0.025" (0,6 mm) wire. If the drive roll slips while feeding wire, the pressure should be increased until the wire feeds properly.
7. Refer to Figure B.5. Remove gas nozzle and contact tip from end of gun.
8. Turn the PRO 155 ON ("I").
9. Straighten the gun cable assembly.
10. Depress the gun trigger switch and feed welding wire through the gun and cable. (Point gun away from yourself and others while feeding wire.) Release gun trigger after wire appears at end of gun.
11. Turn the PRO 155 OFF ("O").
12. Replace contact tip and gas nozzle.
13. Refer to Figure B-6. Cut the wire off 1/4" – 3/8" (6 – 10 mm) from the end of the tip. The PRO 155 is now ready to weld.

FIGURE B.4

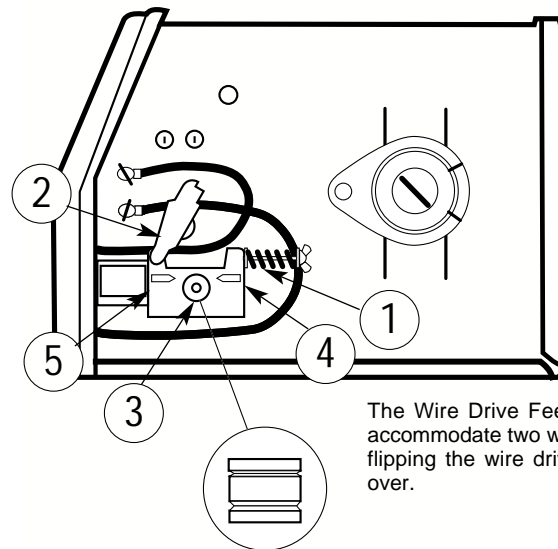

Making A Weld

FIGURE B.5

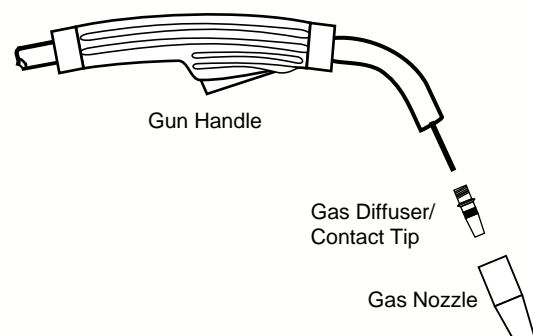

⚠ WARNING

When inching the welding wire, the drive rolls, the gun connector block and the gun contact tip are electrically energized relative to work and ground and remain energized for several seconds after the gun trigger is released.

FIGURE B.6

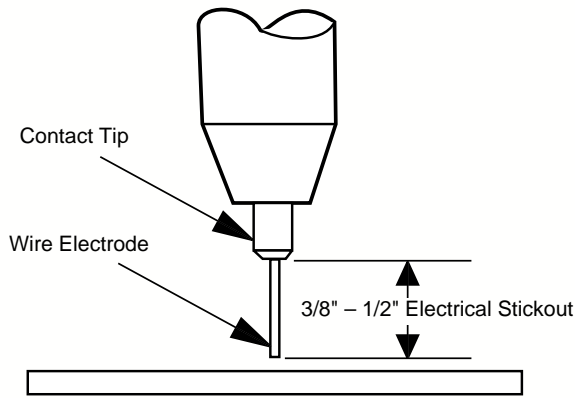

1. See "Process Guidelines" in this section for selection of welding wire and shielding gas and for range of metal thicknesses that can be welded.
2. See the Application chart on the inside of the wire feed compartment door for information on setting the PRO 155 controls. Refer to Table B.1 for aluminum and stainless wire.
3. Set the Voltage ("V") and Wire Speed ("olo") controls to the settings suggested for the welding wire and base metal thickness being used, refer to Applications chart on the inside of the wire drive compartment door.
4. Check that the polarity is correct for the welding wire being used and that the gas supply, if required, is turned on.
5. When using Innershield electrode, remove the gas nozzle and install the gasless nozzle. This will improve visibility of the arc and protect the gas diffuser from weld spatter. Refer to the MAINTENANCE section for details on nozzle replacement.
6. Refer to Figure B.7. Connect work clamp to metal

FIGURE B.7

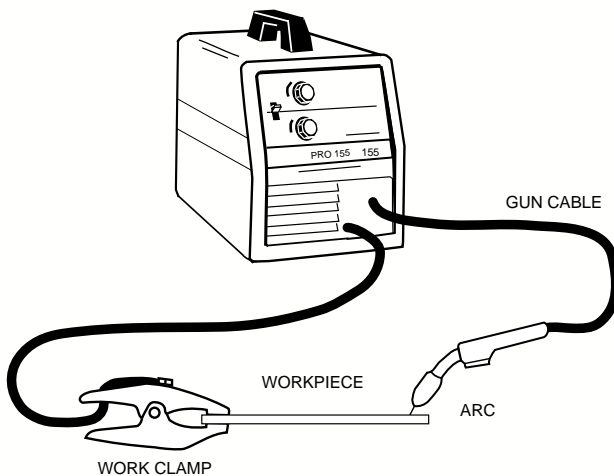

to be welded. Work clamp must make good electrical contact to the workpiece. The workpiece must also be grounded as stated in "Arc Welding Safety Precautions" in the beginning of this manual.

7. Position gun over joint. End of wire may be lightly touching the work.
8. Lower welding helmet, close gun trigger, and begin welding. Hold the gun so the contact tip to work distance is about 3/8 inch (10 mm).
9. To stop welding, release the gun trigger and then pull the gun away from the work after the arc goes out.
10. When no more welding is to be done, close valve on gas cylinder (if used), momentarily operate gun trigger to release gas pressure, and turn off the PRO 155.

Cleaning Tip And Nozzle

Clean the contact tip and nozzle to avoid arc bridging between the nozzle and contact tip which can result in a shorted nozzle, poor welds and an overheated gun. Hint: Anti-stick spray or gel, available from a welding supply distributor, may reduce buildup and aid in spatter removal.

PROCESS GUIDELINES

The PRO 155 can be used for welding mild steel using the self shielded, Innershield electrode process or it can be used for the GMAW (MIG), single pass, process which requires a supply of shielding gas, a KP665-035 drive roll and the K610-2 MIG Conversion Kit.

The recommended electrode for the self-shielded process is 0.045" (1.2 mm) diameter Lincoln Innershield NR-211-MP on 10 lb (4.5 kg) spools. This electrode can be used for all position welding of 20 gauge through 9 gauge thick steel. The .045" (1.2 mm) NR-211-MP can also be used for welding galvanized sheet metal.

The recommended gas and electrode for GMAW is welding grade CO₂ gas and 0.025" (0.6 mm) diameter Lincoln L-56 mild-steel welding wire [supplied on 2 lb (.90 kg) spools]. For 14 gauge (2.0 mm) and thinner, CO₂ or blended gas is acceptable.

A mixed gas consisting of 75 to 80% Argon and 20 to 25% CO₂ is recommended for welding on heavier

gauge [14 gauge (2.0 mm) for example] steel.

The PRO 155 is suitable for .035" aluminum wire and .030" stainless wire when a K664-1 Aluminum Feeding kit is used. Refer to Table B.1 for recommended procedure settings.

TABLE B.1

Process	Welding Wire	Shielding Gas	Voltage/Wire Speed			
			16 ga	14 ga	12 ga	10 ga
MIG DC+	.035 Dia 4043 Aluminum Wire	100% Argon	B-5	D-7	D-9	D-9
MIG DC+	.035 Dia 5356 Aluminum Wire	100% Argon	B-5	C-7	D-9	D-10
MIG DC+	.030 Dia 308L Stainless Steel Wire	98% Argon/ 2% Oxygen	A-3	C-6	D-7.5	D-7.5

CHANGING MACHINE OVER TO FEED OTHER WIRE SIZES

The PRO 155 is shipped from the factory ready to feed 0.045" (1.2 mm) diameter wire. To operate the PRO 155 with other sizes of wire, it is necessary to change the contact tip and change the drive roll over to other sizes. Refer to Changing the Contact Tip and Changing the Drive Roll, in the MAINTENANCE section, for specific information on these procedures.

WELDING WITH GMAW (MIG)

Shielding Gas

When using the GMAW process, obtain and install the K610-2 MIG Conversion Kit, a KP665-035 drive roll and a cylinder of carbon dioxide (CO₂) or argon-carbon dioxide mixed shielding gas. Refer to the ACCESSORIES section for more information about installing the K610-2 Kit for use with the PRO 155.

1. For CO₂, open the cylinder very slowly. For argon-mixed gas, open cylinder valve slowly a fraction of a turn. When the cylinder pressure gauge pointer stops moving, open the valve fully.
2. If using a regulator with an adjustable flow meter, close the gun trigger and adjust the flow to give 15

– 20 cubic ft per hour (CFH) (7 – 10 l/min) [use 20 – 25 CFH (10 – 12 l/min) when welding out of position or in a drafty location for CO₂]. For argon mixed gas, trigger to release gas pressure, and turn off the adjust the flow to give 25 – 30 CFH (12 – 14 l/min).

3. Keep the cylinder valve closed, except when using the PRO 155. When finished welding:
 - a) Close the cylinder valve to stop gas flow.
 - b) Depress the gun trigger briefly to release the pressure in the gas hose.
 - c) Turn off the PRO 155.

OVERLOAD PROTECTION

Output Overload

The PRO 155 is equipped with a circuit breaker and a thermostat which protects the machine from damage if maximum output is exceeded. The circuit breaker button will extend out when tripped. The circuit breaker must be manually reset.

Thermal Protection

If the duty cycle of the machine is exceeded, a thermal protector will shut off the output until the machine cools to a reasonable operating temperature. The fan will continue to run during cooling.

Electronic Wire Drive Motor Protection

The PRO 155 has built-in protection for wire drive motor overload.

LEARNING TO WELD

No one can learn to weld simply by reading about it. Skill comes only with practice. The following pages will help the inexperienced operator to understand welding and develop this skill. For more detailed information, order a copy of "New Lessons in Arc Welding" listed at the end of this manual.

THE ARC-WELDING CIRCUIT

The operator's knowledge of arc welding must go beyond the arc itself. The operator must know how to control the arc, and this requires a knowledge of the welding circuit and the equipment that provides the electric current used in the arc. Figure B.7 illustrates the welding circuit for a typical welding machine. The circuit begins where the gun cable is attached to the welding machine. Current flows through the gun cable, gun, and contact tip, to the wire and across the arc. On the work side of the arc, current flows through the base metal to the work cable and back to the welding machine. This circuit must be complete for the current to flow.

This machine's welding circuit has a voltage output of 32 volts DC maximum. This voltage is quite low and is only present when the gun triggers depressed.

To weld, the work clamp must be tightly connected to clean base metal. Remove paint, rust, dirt or oil as necessary and connect the work clamp as close as possible to the area you wish to weld. This helps prevent current from going through an unwanted path. Avoid allowing the welding circuit to pass through hinges, bearings, electronic components, or similar devices that can be damaged. See Figure B.8. Always disconnect electrical devices before welding upon them.

FIGURE B.8

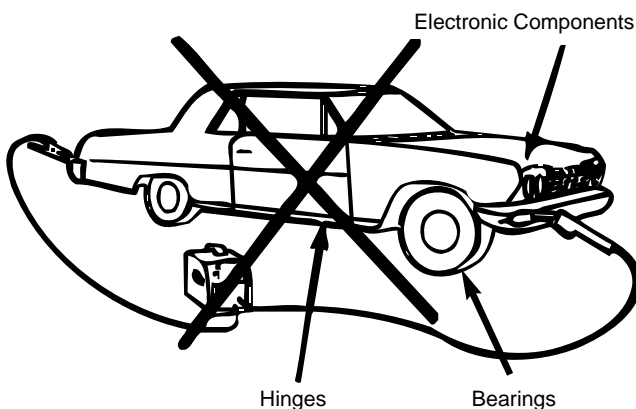

⚠ WARNING



Fumes and slag generated from Innershield type electrodes recommended for use with this welding machine can be toxic.

- Avoid contact with eyes and skin.
- Do not take internally.
- Keep out of reach of children.
- Follow all safety precautions found in this operating manual.

The gun and cable assembly is held by the operator who guides the automatically fed wire along the joint, maintaining a contact tip to work distance of about 3/8 to 1/2 inch (10 – 12 mm) This is called electrical stick-out. This electrical stickout (ESO) must be properly maintained by the operator. The electric arc is made in the gap between the work and the tip end of a small diameter wire. When the power source is properly set, the arc gap is maintained automatically.

Arc welding is a manual skill requiring a steady hand, good physical condition, and good eyesight. The operator controls the welding arc, and, therefore, the quality of the weld made.

THE SELF-SHIELDED FCAW WELDING ARC

Figure B.9 illustrates the action taking place in the self shielded FCAW (Innershield) welding arc. It closely resembles what is actually seen while welding.

FIGURE B.9

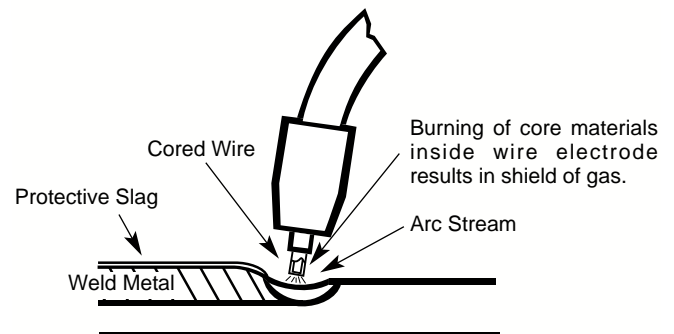

The “arc stream” is seen in the middle of the picture. This is the electric arc created by the electric current flowing through the space between the end of the wire electrode and the base metal. The temperature of this arc is about 6000°F, which is more than enough to melt metal. The arc is very bright, as well as hot, and cannot be looked at with the naked eye without risking painful injury. The very dark lens, specifically designed for arc welding must be used with the hand or face shield whenever viewing the arc.

The arc melts the base metal and actually digs into it much as water through a nozzle on a garden hose digs into the earth. The molten metal forms a molten pool or crater and tends to flow away from the arc. As it moves away from the arc, it cools and solidifies.

The function of the Innershield cored wire electrode is much more than simply to carry current to the arc. The wire core is composed of fluxes and/or alloying ingredients around which a steel sheath has been formed. It is simply a stick electrode turned inside out in a continuous wire form.

The cored wire melts in the arc and tiny droplets of molten metal shoot across the arc into the molten pool. The wire sheath provides additional filler metal for the joint to fill the groove or gap between the two pieces of base metal.

The core materials also melt or burn in the arc and perform several functions. They make the arc steadier, provide a shield of smoke-like gas around the arc to keep oxygen and nitrogen in the air away from the molten metal, and provide a flux for the molten pool. The flux picks up impurities and forms the protective slag on top of the weld during cooling.

After running a weld bead, the slag may be removed with a chipping hammer and wire brush. This improves appearance and allows for inspection of the finished weld.

Since machine size and output characteristics limit the size and type of wire electrode which can be used, Lincoln 0.035' (0.9 mm) NR-211-MP Innershield electrode is recommended for Self-Shielded Flux Cored Arc Welding.

THE GMAW (MIG) WELDING ARC

Figure B.10 illustrates the GMAW (MIG) welding arc. Solid wire does not contain fluxes or ingredients to form its own shielding and no slag forms to protect the molten weld metal. For this reason, a continuous even flow of shielding gas is needed to protect the molten weld metal from atmospheric contaminants such as oxygen and nitrogen. Shielding gas is supplied through the gun and cable assembly, through the gas nozzle and into the welding zone.

FIGURE B.10

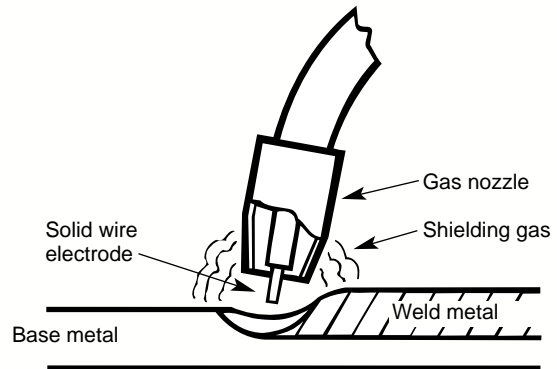

When comparing the GMAW and FCAW processes, you can see that the principal difference between the two lies in the type of shielding used. GMAW uses gas for shielding, thus we have Gas Metal Arc Welding. FCAW uses the melting or burning of the core ingredients for shielding, and is thus termed Self-Shielded Flux Cored Arc Welding.

The recommended wire for Gas Metal Arc Welding (MIG) is Lincolnweld 0.025" L-56 electrode. Lincolnweld" L-56 is capable of welding a wide range of mild steels in all positions, however, more skill IS required for out-of-position welding with the GMAW process.

PROCESS SELECTION

By gaining knowledge of the differences between the two processes, you will be able to select the best process for the job you have at hand. In selecting a process, you should consider:

For GMAW (MIG) Process

1. Is most of my welding performed on 16 gauge and lighter materials?

2. Can I afford the extra expense, space, and lack of portability required for gas cylinders and gas supply?
3. Do I require clean, finished-looking welds?

If you have answered yes to all the above questions GMAW may be the process for you. If you have answered no to any of the above questions, then you should consider using the FCAW process.

For FCAW (Innershield) Process

1. Do I want simplicity and portability?
2. Will welding be performed outdoors or under windy conditions?
3. Do I require good all position welding capability?
4. Will most welding be performed on 16 gauge and heavier, somewhat rusty or dirty materials?
5. Weld must be cleaned prior to painting.

COMMON METALS

Most metals found around the farm, small shop or home are low carbon steel, sometimes referred to as mild steel. Typical items made with this type of steel include most sheet metal, plate, pipe and rolled shapes such as channels and angle irons. This type of steel can usually be easily welded without special precautions. Some steels, however, contain higher carbon levels or other alloys and are more difficult to weld. Basically, if a magnet sticks to the metal and you can easily cut the metal with a file, chances are good that the metal is mild steel and that you will be able to weld the material. In addition, aluminum and stainless steel can be welded using the K664-1 Aluminum Welding Kit. For further information on identifying various types of steels and other metals, and for proper procedures for welding them, we again suggest you purchase a copy of "New Lessons in Arc Welding".

Regardless of the type of metal being welded, in order to get a quality weld, it is important that the metal is free of oil, paint, rust or other contaminants.

MACHINE SET UP FOR THE SELF-SHIELDED FCAW PROCESS

1. See PROCESS GUIDELINES in the OPERATION section for selection of welding wire and shielding gas, and for range of metal thicknesses that can be welded.
2. See the Application Guide on the inside of wire feed section door for information on setting the controls.
3. Set the "Voltage" and "Wire Speed" controls to the settings suggested on the Application Guide for the welding wire and base metal thickness being used. The voltage control is marked "V" and the wire feed speed is marked "olo."
4. Check that the polarity is correct for the welding wire being used. Set the polarity for DC(-) when welding with NR-211-MP Innershield electrode. See Work Cable Installation in the INSTALLATION section for instructions on changing polarity.
5. When using Innershield electrode, the gasless nozzle may be used instead of a gas nozzle to improve visibility of the arc.
6. Connect work clamp to metal to be welded. Work clamp must make good electrical contact to the work piece. The work piece must also be grounded as stated in the "Arc Welding Safety Precautions" at the beginning of this manual.

WELDING TECHNIQUES FOR THE SELF-SHIELDED FCAW PROCESS

Four simple manipulations are of prime importance when welding. With complete mastery of the four, welding will be easy. They are as follows:

1. The Correct Welding Position

Figure B.11 illustrates the correct welding position for right handed people. (For left handed people, it is the opposite.)

Hold the gun (of the gun and cable assembly) in your right hand and hold the shield with your left hand. (Left handers simply do the opposite.)

When using the FCAW Process, weld from left to right (if you are right handed). This enables you to clearly see what you are doing. (Left handers do the opposite.) Tilt the gun toward the direction of travel holding the electrode at an angle as shown in Figure B.11.

FIGURE B.11

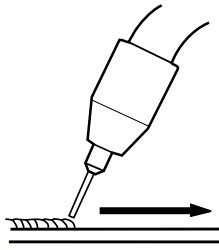

WARNING



ARC RAYS can burn eyes and skin.

When using an open arc process, it is necessary to use correct eye, head and body protection.

Protect yourself and others, read “ARC RAYS can burn” at the front of this manual.

2. The Correct Way To Strike An Arc

1. Be sure the work clamp makes good electrical contact to the work.
2. Position gun over joint. End of wire may be lightly touching the work.
3. Position face shield to protect face and eyes, close gun trigger, and begin welding. Hold the gun so that the contact tip to work distance is about 3/8 to 1/2 inch (10 – 12 mm).
4. To stop welding, release the gun trigger and pull the gun away from the work after the arc goes out.
5. A ball may form at the tip end of the wire after welding. For easier restrikes (with Innershield wire) the ball may be removed by feeding out a few inches of wire and simply bending the wire back and forth until it breaks off.
6. When no more welding is to be done, turn off the machine.

3. The Correct Electrical Stickout (ESO)

The electrical stickout (ESO) is the distance from the end of the contact tip to the end of the wire.

See Figure B.12.

Once the arc has been established, maintaining the correct ESO becomes extremely important.

FIGURE B.12

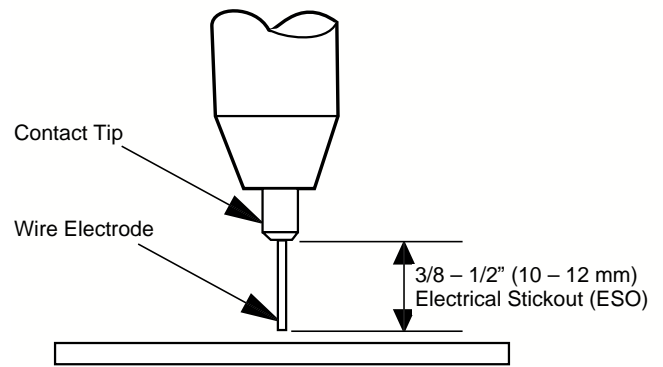

The ESO should be approximately 3/8 to 1/2 inch (10 to 12 mm) long.

The easiest way to tell whether the ESO is the correct length is by listening to its sound. The correct ESO has a distinctive “crackling” sound, very much like eggs frying in a pan. A long ESO has a hollow, blowing or hissing sound. If the ESO is too short, you may stick the contact tip or nozzle to the weld puddle and/or fuse the wire to the contact tip.

4. The Correct Welding Speed

The important thing to watch while welding is the puddle of molten metal right behind the arc. See Figure B.13. Do not watch the arc itself. It is the appearance of the puddle and the ridge where the molten puddle solidifies that indicates correct welding speed. The ridge should be approximately 3/8” (10 mm) behind the wire electrode.

Most beginners tend to weld too fast, resulting in a thin uneven, “wormy” looking bead. They are not watching the molten metal.

FIGURE B.13

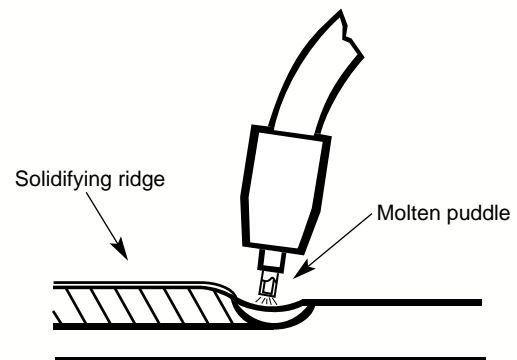

Helpful Hints

1. For general welding, it is not necessary to weave the arc, neither forward or backward nor sideways. Weld along at a steady pace. You will find it easier.
2. When welding on thin plate, you will find that you will have to increase the welding speed, whereas when welding on heavy plate, it is necessary to go more slowly in order to get good penetration.
3. When welding sheet metal 16 gauge (1.5 mm) and lighter, heat buildup may cause part warpage and burn through. One way to eliminate these problems is to use the back-stepping method illustrated in Figure B.14.

FIGURE B.14

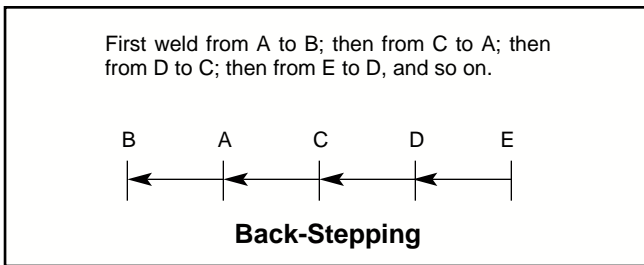

Practice

The best way of getting practice in the four skills that enable you to maintain:

1. Correct welding position
2. Correct way to strike an arc
3. Correct electrical stickout
4. Correct welding speed

is to perform the following exercise.

For the PRO 155, use the following:	
Mild Steel	12 gauge or 1/8 inch (3.0 mm)
Electrode	0.045" (1.2 mm) NR-211-MP Innershield Wire
Voltage Setting "V"	D
Wire Feed Speed "ojo"	3

Refer to Figure B.15.

1. Learn to strike an arc by positioning the gun over the joint and touching the wire to the work.
2. Position face shield to protect face and eyes.
3. Depress gun trigger, hold gun so contact tip to work distance is about 3/8 to 1/2 inch (10 to 12 mm) and the gun is at proper angle.
4. After you strike the arc, practice the correct electrical stickout. Learn to distinguish it by its sound.
5. When you are sure that you can hold the correct electrical stickout, with a smooth "crackling" arc start moving. Look at the molten puddle constantly.
6. Run beads on a flat plate. Run them parallel to the top edge (the edge farthest away from you). This gives you practice in running straight welds, and also gives you an easy way to check your progress. The 10th weld will look considerably better than the first weld. By constantly checking on your mistakes and your progress, welding will soon be a matter of routine.

FIGURE B.15

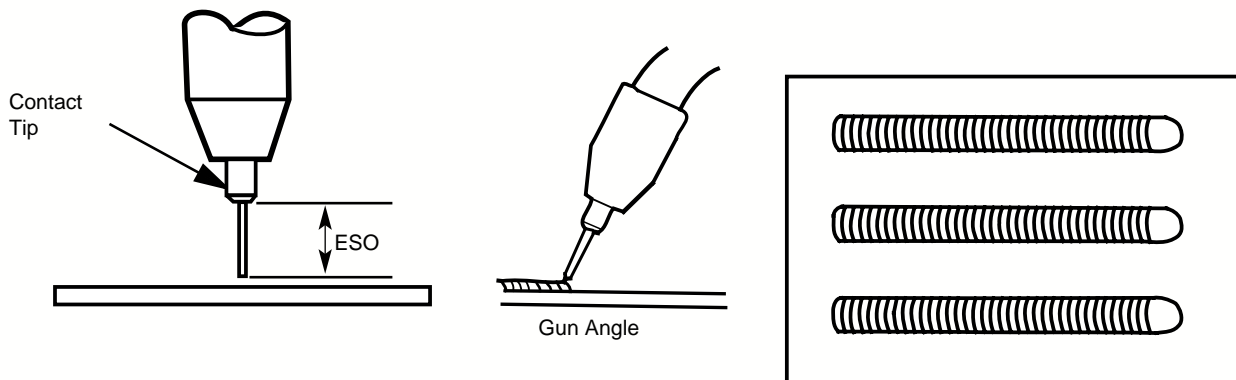

MACHINE SET UP FOR THE GMAW (MIG) PROCESS

1. See PROCESS GUIDELINES in the OPERATION section for selection of welding wire and shielding gas, and for range of metal thicknesses that can be welded.
2. See the Application Guide on the inside of wire feed section door for information on setting the controls.
3. Set the “Voltage” and “Wire Speed” controls to the settings suggested on the Application Guide for the welding wire and base metal thickness being used. The voltage control is marked “V” and the wire feed speed is marked “fpm.”
4. Check that the polarity is correct for the welding wire being used. Set the polarity for DC(+) when welding with the GMAW (MIG) process. See Work Cable Installation in the INSTALLATION section for instructions for changing polarity.
5. Check that the gas nozzle and proper size liner and contact tip are being used and that the gas supply is turned on. If adjustable, set for 15 to 20 cubic feet per hour (7 to 10 l/min.) under normal conditions, increase to as high as 35 CFH (17 l/min.) under drafty (slightly windy) conditions.
6. Connect work clamp to metal to be welded. Work clamp must make good electrical contact to the work piece. The work piece must also be grounded as stated in the “Arc Welding Safety Precautions” at the beginning of this manual.

WELDING TECHNIQUES FOR THE GMAW (MIG) PROCESS

Four simple manipulations are of prime importance when welding. With complete mastery of the four, welding will be easy. They are as follows:

1. The Correct Welding Position

Figure B.16 illustrates the correct welding position for right handed people. (For left handed people, it is the opposite.)

When GMAW (MIG) welding on sheet metal, it is important to use the “forehand” push technique.

Hold the gun (of the gun and cable assembly) in your right hand and hold the shield with your left hand. (Left handers simply do the opposite.)

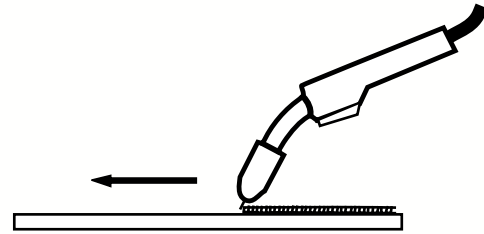

FIGURE B.16

When using the GMAW process on light gauge material, weld from right to left (if you are right handed). This results in a colder weld and has less tendency for burn through.

2. The Correct Way To Strike An Arc

WARNING



ARC RAYS can burn eyes and skin.

When using an open arc process, it is necessary to use correct eye, head and body protection.

Protect yourself and others, read “ARC RAYS can burn” at the front of this manual.

1. Be sure the work clamp makes good electrical contact to the work.
2. Position gun over joint. End of wire may be lightly touching the work.
3. Position face shield to protect face and eyes, close gun trigger, and begin welding. Hold the gun so that the contact tip to work distance is about 3/8 to 1/2 inch (10 – 12 mm).
4. To stop welding, release the gun trigger and pull the gun away from the work after the arc goes out.
5. A ball may form at the tip end of the wire after welding. For easier restrikes, the ball may be removed by feeding out a few inches of wire and cutting off the end of the wire with wire cutters.
6. When no more welding is to be done, close the valve on the gas cylinder, momentarily operate the gun trigger to release gas pressure, then turn off the machine.

FIGURE B.17

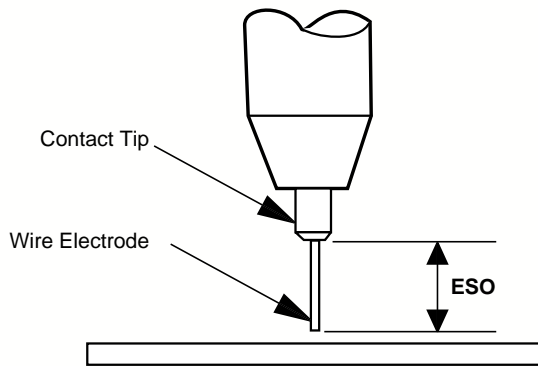

3. The Correct Electrical Stickout (ESO)

The electrical stickout (ESO) is the distance from the end of the contact tip to the end of the wire. See Figure B.17.

Once the arc has been established, maintaining the correct ESO becomes extremely important. The ESO should be approximately 3/8 to 1/2 inch (10 to 12 mm) long.

The easiest way to tell whether the ESO is the correct length is by listening to its sound. The correct ESO has a distinctive “crackling” sound, very much like eggs frying in a pan. A long ESO has a hollow, blowing or hissing sound. If the ESO is too short, you may stick the contact tip or nozzle to the weld puddle and/or fuse the wire to the contact tip.

4. The Correct Welding Speed

The important thing to watch while welding is the puddle of molten metal right behind the arc. See Figure B.18. Do not watch the arc itself. It is the appearance of the puddle and the ridge where the molten puddle solidifies that indicates correct welding speed. The ridge should be approximately 3/8” (10 mm) behind the wire electrode.

Most beginners tend to weld too fast, resulting in a thin, uneven, “wormy” looking bead. They are not watching the molten metal.

FIGURE B.18

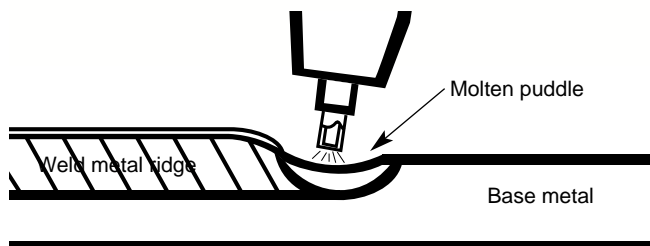

Helpful Hints

1. For general welding, it is not necessary to weave the arc, neither forward or backward nor sideways. Weld along at a steady pace. You will find it easier.
2. When welding on thin plate, you will find that you will have to increase the welding speed, whereas when welding on heavy plate, it is necessary to go more slowly in order to get good penetration.
3. When welding sheet metal 16 gauge (1.5 mm) and lighter, heat buildup may cause part warpage and burn through. One way to eliminate these problems is to use the back-stepping method illustrated in Figure B.14.

Practice

The best way of getting practice in the four skills that enable you to maintain:

1. Correct welding position
2. Correct way to strike an arc
3. Correct electrical stickout
4. Correct welding speed

is to perform the following exercise.

For the PRO 155, use the following:

Mild Steel	16 gauge or 1/16 inch (1.6 mm)
Electrode	Lincolnweld 0.025 L-56 electrode CO ₂
Voltage Setting “V”	C
Wire Feed Speed “o o”	4

Refer to Figure B.15.

1. Learn to strike an arc by positioning the gun over the joint and touching the wire to the work.
2. Position face shield to protect face and eyes.
3. Depress gun trigger, hold gun so contact tip to work distance is about 3/8 to 1/2 inch (10 to 12 mm) and the gun is at proper angle.

4. After you strike the arc, practice the correct electrical stickout. Learn to distinguish it by its sound.
5. When you are sure that you can hold the correct electrical stickout, with a smooth “crackling” arc, start moving. Look at the molten puddle constantly,
6. Run beads on a flat plate. Run them parallel to the top edge (the edge farthest away from you). This gives you practice in running straight welds, and also gives you an easy way to check your progress. The 10th weld will look considerably better than the first weld. By constantly checking on your mistakes and your progress, welding will soon be a matter of routine.

JOINT TYPES AND POSITIONS

Five types of welding joints are: Butt Welds, Fillet Welds, Lap Welds, Edge Welds and Corner Welds. See Figure B.19.

Of these, the Butt Weld and Fillet Weld are the two most common welds.

FIGURE B.19

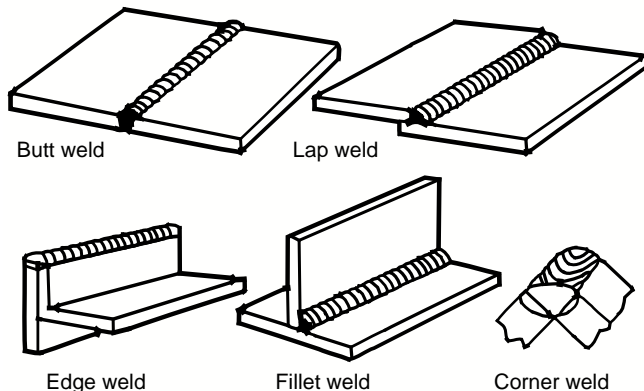

Butt Welds

Place two plates side by side, leaving a space approximately one half the thickness of the metal between them in order to get deeper penetration.

Securely clamp or tack weld the plates at both ends, otherwise the heat will cause the plates to move apart. See Figure B.20.

Now weld the two plates together. Weld from left to right (if right handed). Point the wire electrode down in the crack between the two plates, keeping the gun slightly tilted in the direction of travel.

Watch the molten metal to be sure it distributes itself evenly on both edges and in between the plates.

FIGURE B.20

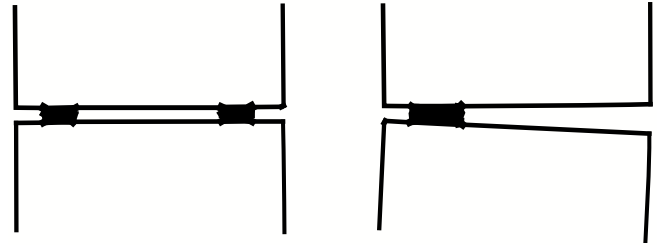

Penetration

Unless a weld penetrates close to 100% of the metal thickness, a butt weld will be weaker than the material welded together. In the example shown in Figure B.21, the total weld is only half the thickness of the material thus the weld is only approximately half as strong as the metal.

FIGURE B.21

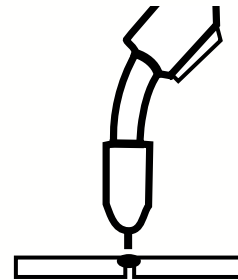
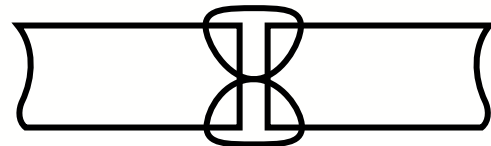

FIGURE B.22



In the example shown in Figure B.22, the joint has been welded so that 100% penetration could be achieved. The weld, if properly made, is as strong as or stronger than the original metal.

Fillet Welds

When welding fillet welds, it is very important to hold the wire electrode at a 45° angle between the two sides or the metal will not distribute itself evenly. The gun nozzle is generally formed at an angle to facilitate this. See Figure B.23.

FIGURE B.23

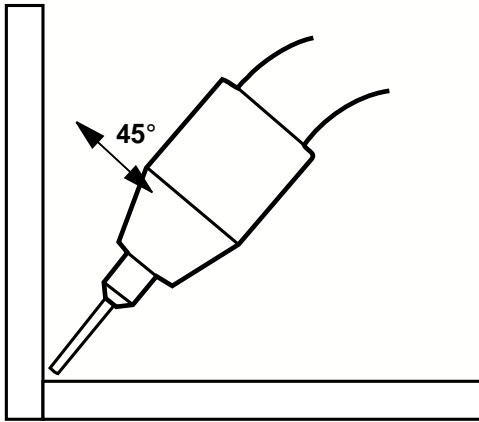
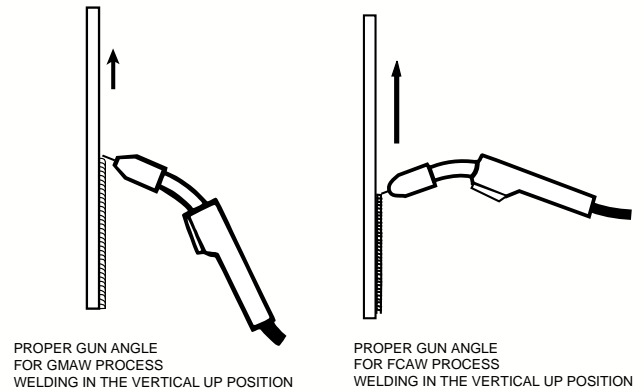

FIGURE B.24



Welding In The Vertical Position

Welding in the vertical position can be done either vertical-up or vertical-down. Vertical-up is used whenever a larger, stronger weld is desired. Vertical-down is used primarily on sheet metal 5/32" (3.9 mm) and under for fast, low penetrating welds.

⚠ WARNING

Use of this unit on thicker materials than recommended may result in poor welds. The welds may "look" good, but may just be "sitting" on top, of the plate. This is called "Cold Casting" and will result in weld failure.

Vertical-up And Overhead Welding

The problem, when welding vertical-up, is to put the molten metal where it is wanted and make it stay there. If too much molten metal is deposited, gravity will pull it downwards and make it "drip". Therefore, a certain technique has to be followed.

When welding out-of-position, run stringer beads. Don't whip, break the arc, move out of the puddle, or move too fast in any direction. Use Wire Feed Speed (WFS) in the low portion of the range. The general technique and proper gun angle is illustrated in Figure B.24.

Generally, keep the electrode nearly perpendicular to the joint as illustrated. The maximum angle above perpendicular may be required if porosity becomes a problem.

Vertical-down Welding

Refer to Figure B.25 Vertical-down welds are applied at a fast pace. These welds are therefore shallow and narrow and, as such, are excellent for sheet metal. Vertical-down welds may be applied to 5/32" (3.9 mm) and lighter material.

Use stringer beads and tip the gun in the direction of travel so the arc force helps hold the molten metal in the joint. Move as fast as possible consistent with desired bead shape.

The important thing is to continue lowering the entire arm as the weld is made so the angle of the gun does not change. Move the electrode wire fast enough that the slag does not catch up with the arc. Vertical-down welding gives thin, shallow welds. It should not be used on heavy material where large welds are required.

FIGURE B.25

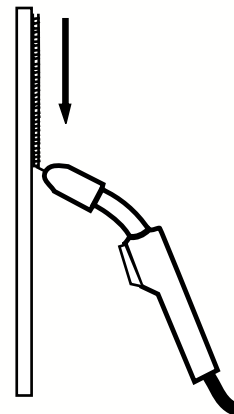

TROUBLESHOOTING WELDS

Good welds have excellent appearance.

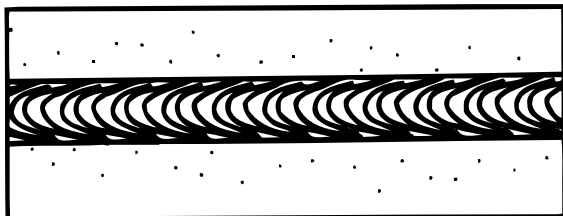

To Eliminate Porosity (in order of importance):

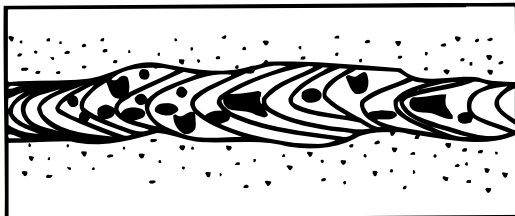

1. Turn on gas supply, if used
2. Decrease voltage.
3. Increase stickout.
4. Increase WFS (wire feed speed).
5. Decrease drag angle.
6. Decrease travel speed.

NOTE: Always be sure the joint is free from moisture, oil, rust, paint or other contaminants.

To Eliminate a Ropy Convex Bead
(in order of importance):

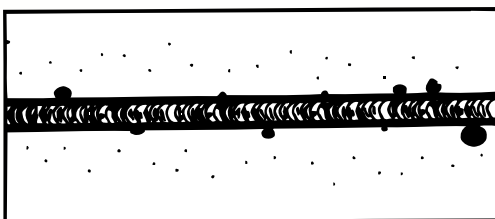

1. Increase voltage.
2. Decrease stickout.
3. Decrease WFS (wire feed speed).
4. Decrease travel speed.
5. Decrease drag angle.
6. Check for correct gas, if used.

To Reduce Spatter (in order of importance):

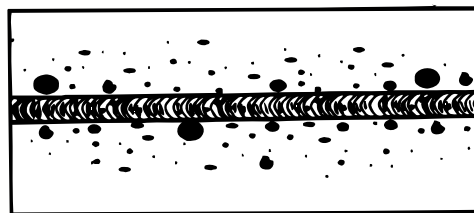

1. Increase voltage.
2. Increase drag angle.
3. Decrease stickout.
4. Increase WFS (wire feed speed).
5. Decrease travel speed.
6. Check for correct gas, if used.

To Correct Poor Penetration (in order of importance):

1. Decrease stickout.
2. Increase WFS (wire feed speed).
3. Decrease voltage.
4. Increase speed.
5. Decrease drag angle.
6. Check for correct gas, if used.

If Arc Blow Occurs (in order of importance):

NOTE: Try different ground connection locations before adjusting procedures.

1. Decrease drag angle.
2. Increase stickout.
3. Decrease voltage.
4. Decrease WFS (wire feed speed).
5. Decrease travel speed.

To Eliminate Stubbing* (in order of importance):

1. Increase voltage
2. Decrease WFS (wire feed speed)
3. Decrease stickout
4. Increase drag angle

* Stubbing occurs when the electrode drives through the molten puddle and hits the bottom plate tending to push the gun up.

PROPER GUN HANDLING

Most feeding problems are caused by improper handling of the gun cable or electrodes.

1. Do not kink or pull the gun around sharp corners
2. Keep the gun cable as straight as practical when welding.
3. Do not allow dolly wheels or trucks to run over the cables.
4. Keep the cable clean.
5. Innershield electrode has proper surface lubrication. Use only clean, rust-free electrode.
6. Replace contact tip when it becomes worn or the end is fused or deformed.

**LINCOLN®
ELECTRIC**

SUGGESTED SETTINGS FOR WELDING
FOR STAINLESS STEEL AND ALUMINUM SETTINGS-SEE MANUAL

**LINCOLN®
ELECTRIC**

PROCESS	WELDING WIRE	SHIELDING GAS	STEEL THICKNESS														
			24 gal/.024 in. 0.60 mm	22 gal/.030 in. 0.80 mm	20 gal/.036 in. 1.0 mm	18 gal/.048 in. 1.2 mm	16 gal/.060 in. 1.6 mm	14 gal/.075 in. 2.0 mm	12 gal/.105 in. 2.5 mm	10 gal/.135 in. 3.5 mm	3/16 in. 5.0 mm	1/4 in. 6.0 mm	5/16 in. 8.0 mm				
GASLESS FLUX-CORED DC(-)	.035 in. (0.9 mm) DIA. INNERSHIELD® NR® -211-MP	NONE															
	.045 in. (1.2 mm) DIA. INNERSHIELD® NR® -211-MP	NONE															
MIG DC(+)	.025 in. (0.6 mm) DIA. SOLID STEEL WIRE LINCOLN WELD® L-56	CO ₂	A-2	B-3	B-3	C-4	A-1.5	B-2	C-2.5	C-1.5	E-8						
		C20 or C25 (75-80% Argon, 25-20% CO ₂)	A-2	B-3	B-3	C-4.5	C-4.5	D-7	E-10								
	CO ₂																
	.030 in. (0.8 mm) DIA. SOLID STEEL WIRE LINCOLN WELD® L-56	C20 or C25 (75-80% Argon, 25-20% CO ₂)	A-2	B-2.5	B-2.5	C-3.5	C-3.5	D-5.5	E-7.5	E-6							

*Multiple passes req'd.

DRIVE ROLL ORIENTATION

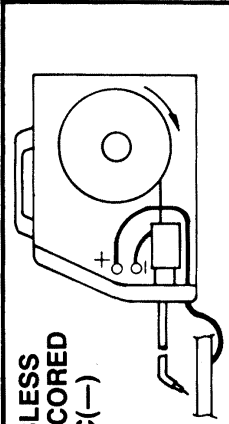
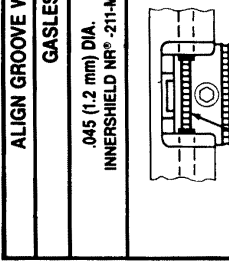
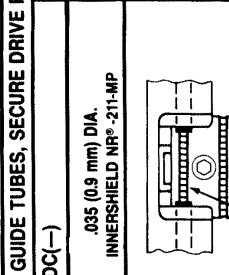
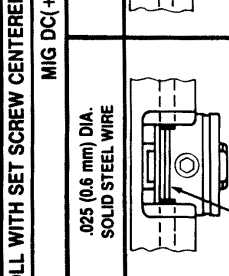
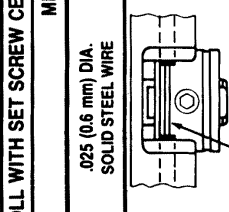
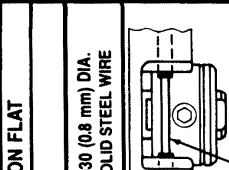
ALIGN GROOVE WITH CENTER OF GUIDE TUBES, SECURE DRIVE ROLL WITH SET SCREW CENTERED ON FLAT	GASLESS FLUX-CORED DC(-)	
 <p>MIG DC(+)</p>	.045 (1.2 mm) DIA. INNERSHIELD NR® -211-MP	 <p>EITHER GROOVE</p>
	.035 (0.9 mm) DIA. INNERSHIELD NR® -211-MP	 <p>EITHER GROOVE</p>
 <p>GASLESS FLUX-CORED DC(-)</p>	.025 (0.6 mm) DIA. SOLID STEEL WIRE	 <p>SMALL GROOVE (BEVEL SIDE)</p>
	.030 (0.8 mm) DIA. SOLID STEEL WIRE	 <p>LARGE GROOVE</p>

Be sure to read and understand the warnings on this welding machine and the section on ARC WELDING SAFETY PRECAUTIONS in the Operating Manual. Because design, fabrication, assembly and welding variables affect the results obtained in applying this type of information, the serviceability of a product or assembly is the responsibility of the builder/user.

WARNING: WHEN THE WELDING POWER SOURCE IS ON AND THE GUN TRIGGER IS PRESSED, THE WIRE REEL AND ELECTRODE ARE ELECTRICALLY HOT.

AVERTISSEMENT: QUAND LA PISTOLE EST ENFONCEE ET QUE LA DETENTE DU PISTOLET EST ENFORCEE, LES ROULEAUX D'ENTRAÎNEMENT, LE DEVIDOIR ET L'ELECTRODE SONT MIS SOUS TENSION.

OUTPUT POLARITY

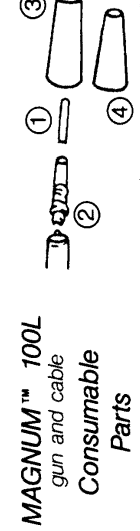
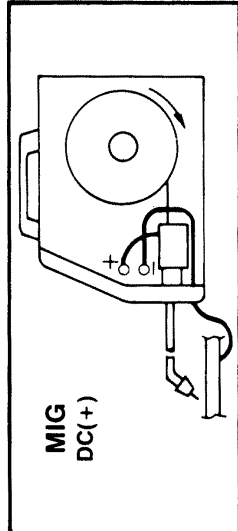
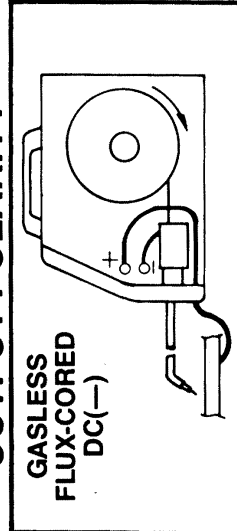

① **For MIG**

Part No. S19726-1R	Wire Dia. .023 - .025 in.
Part No. S19726-2R	Wire Dia. .030 in.

② **Contact Tips**

③ **For Flux-Cored**

Part No. S19726-3R	Wire Dia. .035 in.
Part No. S19726-4R	Wire Dia. .045 in.

④ **Gas Diffuser/Tip Holder**

Part No. S19728-R

⑤ **Nozzle-MIG Wire**

Part No. M16294-R

⑥ **Nozzle-Flux-Cored Wire**

Part No. M16418-R

FC155 L9639

OPTIONAL ACCESSORIES

1. **K520 Utility Cart** — Designed to transport the Lincoln family of small welders. Has provisions for mounting a single gas cylinder. Has front casters and large rear wheels. Handle height is easily adjustable. Bottom tray provided for tools and accessories. Easy assembly required; takes less than 15 minutes.
2. **K664-2 Aluminum Feeding Kit** — This kit required for welding with .035 Aluminum wire. This kit may also be used for feeding .030 stainless wire. Included with this kit are a drive roll, liner and contact tip. **It is important when changing between welding with steel wire and aluminum wire to exchange these components due to the lubricant applied to steel wire. Failure to do so may result in contaminated welds when welding aluminum.**
3. **K610-2 MIG Conversion Kit for the PRO 155** — Complete kit for use with .023-.025" (0.6 mm) electrode wire and either CO₂ or Argon-mixed gas. Includes .025-.030" (0.6-0.8 mm) cable liner, two .023-.025" (0.6 mm) contact tips, gas nozzle, 2 lb. spool of .025" (0.6 mm) L-56 electrode, gas regulator, gas hose, regulator adapter for CO₂ cylinders and gas solenoid assembly, with all the necessary hardware and easy instructions for installing the gas solenoid. Use with .030" (0.8 mm) wire requires additional .030" (0.8 mm) contact tip and electrode wire. Also requires a KP665-035 drive roll for feeding all the wire sizes mentioned above.

MIG CONVERSION

Several changes are needed to convert the unit for operation with the MIG (GMAW) process. The KP665-035 drive roll and the K610-2 MIG Conversion Kit for the PRO 155 include all the necessary accessories for this conversion and are provided for this purpose. The following conversions should be made using the contents of this kit and the drive roll:

1. Install the gas solenoid. Complete instructions are included with the kit.
2. Change the output polarity to DC(+). See "Work Cable Installation" in Installation section for details.
3. Change the drive roll for the wire size selected. See "Changing Drive Roll" in the Maintenance section for details.
4. Install the proper gun liner and tip for the wire size selected. See "Component Replacement" in the Maintenance section for details.
5. Remove the gasless nozzle (if installed) and install the gas nozzle. To remove it, simply unscrew it.
6. Load the wire into the machine and thread it into the gun and cable per "Welding Wire Loading" section.

MAINTENANCE

SAFETY PRECAUTIONS

WARNING



ELECTRIC SHOCK can kill.

- Disconnect input power by removing plug from receptacle before working inside PRO 155. Use only grounded receptacle. Do not touch electrically “hot” parts inside PRO 155.

- Have qualified personnel do the maintenance and trouble shooting work.

ROUTINE MAINTENANCE

POWER SOURCE COMPARTMENT

No user serviceable parts inside! Do not attempt to perform service in the power source (fixed) side of the PRO 155. Take the unit to an authorized Lincoln Service Center if you experience problems. NO maintenance is required.

WIRE FEED COMPARTMENT

1. When necessary, vacuum accumulated dirt from gearbox and wire feed section.
2. Occasionally inspect the incoming guide tube and clean inside diameter is necessary.
3. Motor and gearbox have lifetime lubrication and require no maintenance.

FAN MOTOR

Has lifetime lubrication — requires no maintenance.

WIRE REEL SPINDLE

Requires no maintenance. Do **not** lubricate shaft.

PRO 155

LINCOLN[®]
ELECTRIC

GUN AND CABLE MAINTENANCE

FOR MAGNUM™ 100L GUN

Gun Cable Cleaning

Clean cable liner after using approximately 300 lbs (136 kg) of solid wire or 50 lbs (23 kg) of flux-cored wire. Remove the cable from the wire feeder and lay it out straight on the floor. Remove the contact tip from the gun. Using low pressure air, gently blow out the cable liner from the gas diffuser end.

CAUTION

Excessive pressure at the start may cause the dirt to form a plug.

.....

Flex the cable over its entire length and again blow out the cable. Repeat this procedure until no further dirt comes out.

Contact Tips, Nozzles, and Gun Tubes

1. Dirt can accumulate in the contact tip hole and restrict wire feeding. After each spool of wire is used, remove the contact tip and clean it by pushing a short piece of wire through the tip repeatedly. Use the wire as a reamer to remove dirt that may be adhering to the wall of the hole through the tip.
2. Replace worn contact tips as required. A variable or "hunting" arc is a typical symptom of a worn contact tip. To install a new tip, choose the correct size contact tip for the electrode being used (wire size is stenciled on the side of the contact tip) and screw it snugly into the gas diffuser.
3. Remove spatter from inside of the gas nozzle and from the tip after each 10 minutes of arc time or as required.
4. Be sure the gas nozzle is fully screwed onto the diffuser for gas shielded processes. For the Innershield® process, the gasless nozzle should be screwed onto the diffuser.

5. To remove the gun tube from the gun, remove the gas nozzle or gasless nozzle and remove the diffuser from the gun tube. Remove both collars from each end of the gun handle and separate the handle halves. Loosen the locking nut holding the gun tube in place against the gun end cable connector. Unscrew the gun tube from the cable connector. To install the gun tube, screw the locking nut on the gun tube as far as possible. Then screw the gun tube into the cable connector until it bottoms. Then unscrew (no more than one turn) the gun tube until its axis is perpendicular to the flat sides of the cable connector and pointed in the direction of the trigger. Tighten the locking nut so as to maintain the proper relationship between the gun tube and the cable connector. Replace the gun handle, trigger and diffuser. Replace the gas nozzle or gasless nozzle.

COMPONENT REPLACEMENT PROCEDURES

CHANGING THE CONTACT TIP

1. Refer to Figure D.2. Remove the gas nozzle from the gun by unscrewing it counter-clockwise.
2. Remove the existing contact tip from the gun by unscrewing it counter-clockwise.
3. Insert and hand tighten the desired contact tip.
4. Replace the gas nozzle.

CHANGING DRIVE ROLL

FIGURE D.1

The drive roll has two knurled grooves; both for .035-.045 (0.9-1.2 mm) flux-cored steel electrode.

If .023" – .025" (0.6 mm) wire is to be used, the drive roll must be changed to a KP665-035 as follows:

1. Connect the machine to its rated input power per instructions in Installation section.
2. Release the spring-loaded pressure arm and lift the idle roll arm away from the drive roll.
3. Turn the power switch to ON (marked "I").
4. Set the wire speed to minimum and jog the drive unit with the trigger switch until the drive roll set screw is facing up.

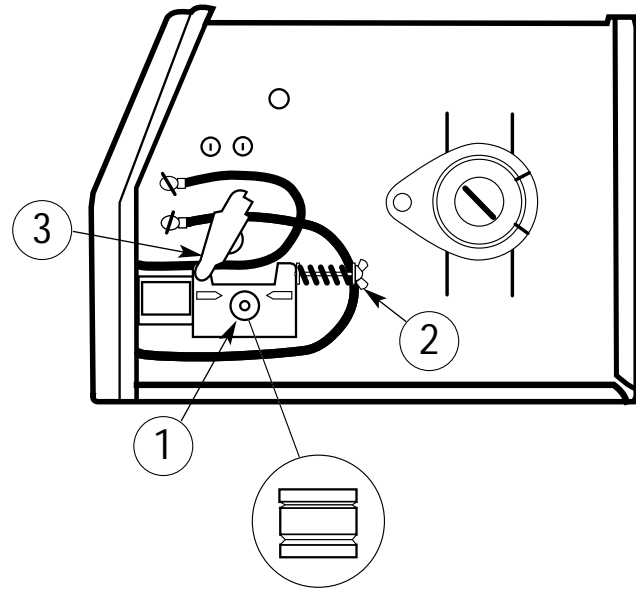

⚠ CAUTION

When inching the welding wire, the drive rolls, gun connector block, and gun contact tip are energized relative to work and ground and remain energized for several seconds after the gun trigger is released.

5. Turn the power switch to OFF (marked "O").
6. Loosen the drive roll set screw with the 5/64" (2.0 mm) hex wrench supplied.
7. Remove the drive roll and replace it with the KP665-035 with the .023 – .025" (0.6 mm) groove (the smaller groove) closest to the gearbox.
8. Push a length of straightened welding wire through the wire feeder guide tubes and adjust the position of the drive roll so that the groove is centered on the wire. Make certain the set screw is located on the flat portion of the shaft and tighten.

FIGURE D.2
Liner trim length

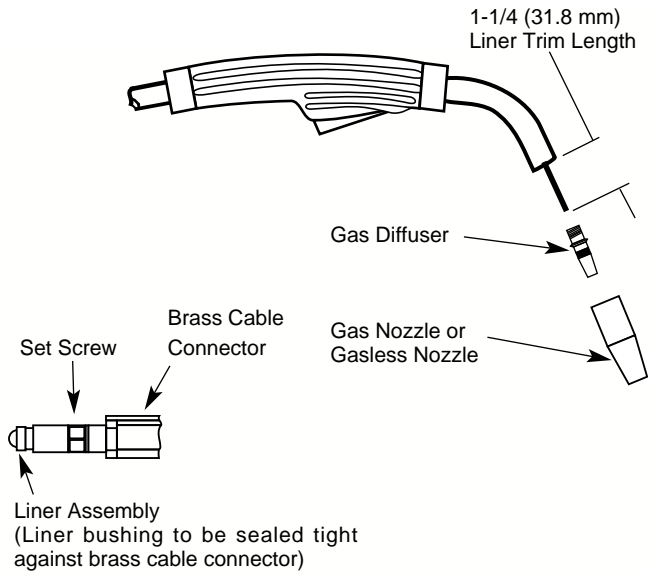

7. With the gas nozzle and diffuser removed from the gun tube, be sure the cable is straight, and then trim the liner to the length shown in Figure D.2. Remove any burrs from the end of the liner.
8. Screw the gas diffuser onto the end of the gun tube and securely tighten it.
9. Replace the contact tip and nozzle.

GUN HANDLE PARTS

The gun handle consists of two halves that are held together with a collar on each end. To open up the handle, turn the collars approximately 60 degrees counter-clockwise until the collar reaches a stop. Then pull the collar off the gun handle. If the collars are difficult to turn, position the gun handle against a corner, place a screwdriver against the tab on the collar and give the screwdriver a sharp blow to turn the collar past an internal locking rib. See Figure D-3.

CHANGING LINER

NOTICE: The variation in cable lengths prevents the interchangeability of liners. Once a liner has been cut for a particular gun, it should not be installed in another gun unless it can meet the liner cutoff length requirement. Refer to Figure D.2.

1. Remove the gas nozzle from the gun by unscrewing it counter-clockwise.
2. Remove the existing contact tip from the gun by unscrewing it counter-clockwise.
3. Remove the gas diffuser from the gun tube by unscrewing it counter-clockwise.
4. Lay the gun and cable out straight on a flat surface. Loosen the set screw located in the brass connector at the wire feeder end of the cable. Pull the liner out of the cable.
5. Insert a new untrimmed liner into the connector end of the cable. Be sure the liner bushing is stenciled appropriately for the wire size being used.
6. Fully seat the liner bushing into the connector. Tighten the set screw on the brass cable connector. At this time, the gas diffuser should not be installed onto the end of the gun tube.

FIGURE D.3

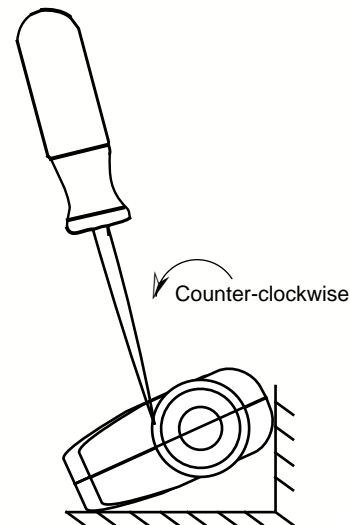

HOW TO USE TROUBLESHOOTING GUIDE

WARNING

Service and Repair should only be performed by Lincoln Electric Factory Trained Personnel. Unauthorized repairs performed on this equipment may result in danger to the technician and machine operator and will invalidate your factory warranty. For your safety and to avoid Electrical Shock, please observe all safety notes and precautions detailed throughout this manual.

This Troubleshooting Guide is provided to help you locate and repair possible machine malfunctions. Simply follow the three-step procedure listed below.

Step 1. LOCATE PROBLEM (SYMPTOM).

Look under the column labeled "PROBLEM (SYMPTOMS)". This column describes possible symptoms that the machine may exhibit. Find the listing that best describes the symptom that the machine is exhibiting.

Step 2. POSSIBLE CAUSE.

The second column labeled "POSSIBLE CAUSE" lists the obvious external possibilities that may contribute to the machine symptom.

Step 3. RECOMMENDED COURSE OF ACTION

This column provides a course of action for the Possible Cause, generally it states to contact your local Lincoln Authorized Field Service Facility.

If you do not understand or are unable to perform the Recommended Course of Action safely, contact your local Lincoln Authorized Field Service Facility.

CAUTION

If for any reason you do not understand the test procedures or are unable to perform the tests/repairs safely, contact your **Local Lincoln Authorized Field Service Facility** for technical troubleshooting assistance before you proceed.

Observe all Safety Guidelines detailed throughout this manual

PROBLEMS (SYMPTOMS)	POSSIBLE AREAS OF MISADJUSTMENT(S)	RECOMMENDED COURSE OF ACTION
OUTPUT PROBLEMS		
Major physical or electrical damage is evident.	None Contact your local Authorized Field Service Facility.	
No wire feed, weld output or gas flow when gun trigger is pulled. Fan does NOT operate.	<ol style="list-style-type: none"> 1. Make sure correct voltage is applied to the machine. Refer to "Installation" section. 2. Make certain that power switch is in the ON position. 3. Make sure circuit breaker inside wire drive compartment is reset. 	<p>If all recommended possible areas of misadjustment have been checked and the problem persists, Contact your local Lincoln Authorized Field Service Facility.</p>
No wire feed, weld output or gas flow when gun trigger is pulled Fan operates normally.	<ol style="list-style-type: none"> 1. The thermostat may be tripped due to overheating. Let machine cool. Weld at lower duty cycle. 2. Check for obstructions in air flow. Check Gun Trigger connections. See Installation section. 3. Gun trigger may be faulty. 	

⚠ CAUTION

If for any reason you do not understand the test procedures or are unable to perform the tests/repairs safely, contact your **LOCAL AUTHORIZED LINCOLN ELECTRIC FIELD SERVICE FACILITY** for assistance before you proceed.

Observe all Safety Guidelines detailed throughout this manual

PROBLEMS (SYMPTOMS)	POSSIBLE AREAS OF MISADJUSTMENT(S)	RECOMMENDED COURSE OF ACTION
FEEDING PROBLEMS		
No wire feed when gun trigger is pulled. Fan runs, gas flows and machine has correct open circuit voltage (33vcd maximum) – weld output.	<ol style="list-style-type: none"> 1. If the wire drive motor is running make sure that the correct drive rolls are installed in the machine. 2. Check for clogged cable liner or contact tip. 3. Check for proper size cable liner and contact tip. 	If all recommended possible areas of misadjustment have been checked and the problem persists, Contact your local Lincoln Authorized Field Service Facility.

PROBLEMS (SYMPTOMS)	POSSIBLE AREAS OF MISADJUSTMENT(S)	RECOMMENDED COURSE OF ACTION
GAS FLOW PROBLEMS		
Low or no gas flow when gun trigger is pulled. Wire feed, weld output and fan operate normally. (Optional MIG Conversion Kit only.)	<ol style="list-style-type: none"> 1. Verify that gas solenoid is properly installed. Refer to instructions included with K610-2 MIG conversion kit. 2. Check gas supply, flow regulator and gas hoses. 3. Check gun connection to machine for obstruction or leaky seals. 	If all recommended possible areas of misadjustment have been checked and the problem persists, Contact your local Lincoln Authorized Field Service Facility.

⚠ CAUTION

If for any reason you do not understand the test procedures or are unable to perform the tests/repairs safely, contact your **LOCAL AUTHORIZED LINCOLN ELECTRIC FIELD SERVICE FACILITY** for assistance before you proceed.

Observe all Safety Guidelines detailed throughout this manual

PROBLEMS (SYMPTOMS)	POSSIBLE AREAS OF MISADJUSTMENT(S)	RECOMMENDED COURSE OF ACTION
WELDING PROBLEMS		
Arc is unstable – Poor starting	<ol style="list-style-type: none"> 1. Check for correct input voltage to machine – 208 vac or 230 vac. Refer to “Installation” section.. 2. Check for proper electrode polarity for process. 3. Check gun tip for wear or damage and proper size – Replace. 4. Check for proper gas and flow rate for process. (For MIG only.) 5. Check work cable for loose or faulty connections. 6. Check gun for damage or breaks. 7. Check for proper drive roll orientation and alignment. 8. Check liner for proper size. 	<p>If all recommended possible areas of misadjustment have been checked and the problem persists, Contact your local Lincoln Authorized Field Service Facility.</p>

 **CAUTION**

If for any reason you do not understand the test procedures or are unable to perform the tests/repairs safely, contact your **LOCAL AUTHORIZED LINCOLN ELECTRIC FIELD SERVICE FACILITY** for assistance before you proceed.

PRO 155 WIRING DIAGRAM

PRO 155 WIRING DIAGRAM

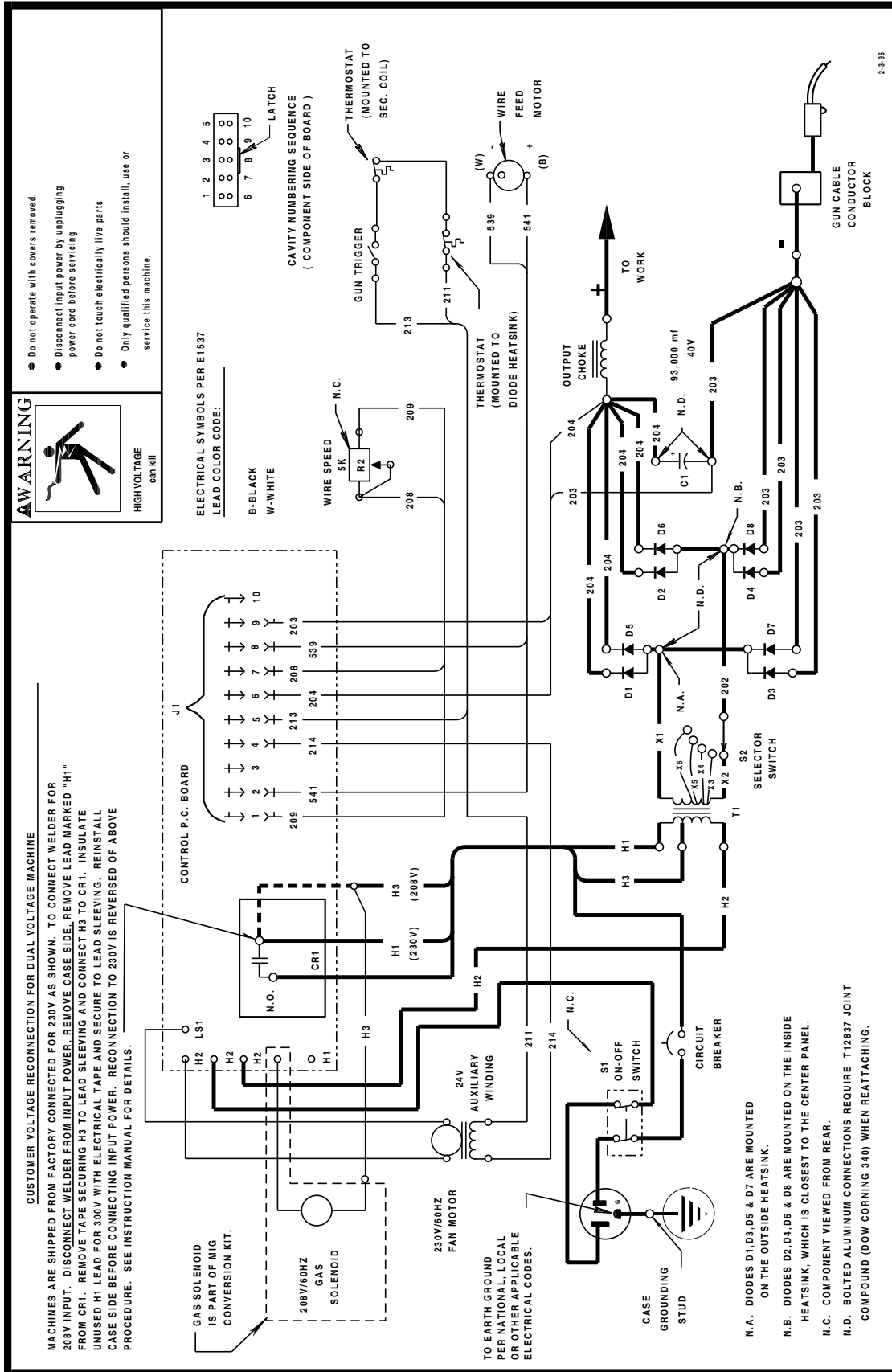

M18202

NOTE: This diagram is for reference only. It may not be accurate for all machines covered by this manual. The specific diagram for a particular code is pasted inside the machine on one of the enclosure panels.

NOTES

			
WARNING	<ul style="list-style-type: none"> ● Do not touch electrically live parts or electrode with skin or wet clothing. ● Insulate yourself from work and ground. 	<ul style="list-style-type: none"> ● Keep flammable materials away. 	<ul style="list-style-type: none"> ● Wear eye, ear and body protection.
Spanish AVISO DE PRECAUCION	<ul style="list-style-type: none"> ● No toque las partes o los electrodos bajo carga con la piel o ropa mojada. ● Aislese del trabajo y de la tierra. 	<ul style="list-style-type: none"> ● Mantenga el material combustible fuera del área de trabajo. 	<ul style="list-style-type: none"> ● Protéjase los ojos, los oídos y el cuerpo.
French ATTENTION	<ul style="list-style-type: none"> ● Ne laissez ni la peau ni des vêtements mouillés entrer en contact avec des pièces sous tension. ● Isolez-vous du travail et de la terre. 	<ul style="list-style-type: none"> ● Gardez à l'écart de tout matériel inflammable. 	<ul style="list-style-type: none"> ● Protégez vos yeux, vos oreilles et votre corps.
German WARNUNG	<ul style="list-style-type: none"> ● Berühren Sie keine stromführenden Teile oder Elektroden mit Ihrem Körper oder feuchter Kleidung! ● Isolieren Sie sich von den Elektroden und dem Erdboden! 	<ul style="list-style-type: none"> ● Entfernen Sie brennbares Material! 	<ul style="list-style-type: none"> ● Tragen Sie Augen-, Ohren- und Körperschutz!
Portuguese ATENÇÃO	<ul style="list-style-type: none"> ● Não toque partes elétricas e electrodos com a pele ou roupa molhada. ● Isole-se da peça e terra. 	<ul style="list-style-type: none"> ● Mantenha inflamáveis bem guardados. 	<ul style="list-style-type: none"> ● Use proteção para a vista, ouvido e corpo.
Japanese 注意事項	<ul style="list-style-type: none"> ● 通電中の電気部品、又は溶材にヒフやぬれた布で触れないこと。 ● 施工物やアースから身体が絶縁されている様にして下さい。 	<ul style="list-style-type: none"> ● 燃えやすいものの側での溶接作業は絶対にしてはなりません。 	<ul style="list-style-type: none"> ● 目、耳及び身体に保護具をして下さい。
Chinese 警告	<ul style="list-style-type: none"> ● 皮膚或濕衣物切勿接觸帶電部件及鋸條。 ● 使你自己與地面和工件絕緣。 	<ul style="list-style-type: none"> ● 把一切易燃物品移離工作場所。 	<ul style="list-style-type: none"> ● 佩戴眼、耳及身體勞動保護用具。
Korean 위험	<ul style="list-style-type: none"> ● 전도체나 용접봉을 젖은 헝겊 또는 피부로 절대 접촉치 마십시오. ● 모재와 접지를 접촉치 마십시오. 	<ul style="list-style-type: none"> ● 인화성 물질을 접근시키지 마십시오. 	<ul style="list-style-type: none"> ● 눈, 귀와 몸에 보호장구를 착용하십시오.
Arabic تحذير	<ul style="list-style-type: none"> ● لا تلمس الاجزاء التي يسري فيها التيار الكهربائي أو الإلكترود بجلد الجسم أو بالملايس المبللة بالماء. ● ضع عازلا على جسمك خلال العمل. 	<ul style="list-style-type: none"> ● ضع المواد القابلة للاشتعال في مكان بعيد. 	<ul style="list-style-type: none"> ● ضع أدوات وملابس واقية على عينيك وأذنيك وجسمك.

READ AND UNDERSTAND THE MANUFACTURER'S INSTRUCTION FOR THIS EQUIPMENT AND THE CONSUMABLES TO BE USED AND FOLLOW YOUR EMPLOYER'S SAFETY PRACTICES.

SE RECOMIENDA LEER Y ENTENDER LAS INSTRUCCIONES DEL FABRICANTE PARA EL USO DE ESTE EQUIPO Y LOS CONSUMIBLES QUE VA A UTILIZAR, SIGA LAS MEDIDAS DE SEGURIDAD DE SU SUPERVISOR.

LISEZ ET COMPRENEZ LES INSTRUCTIONS DU FABRICANT EN CE QUI REGARDE CET EQUIPMENT ET LES PRODUITS A ETRE EMPLOYES ET SUIVEZ LES PROCEDURES DE SECURITE DE VOTRE EMPLOYEUR.

LESEN SIE UND BEFOLGEN SIE DIE BETRIEBSANLEITUNG DER ANLAGE UND DEN ELEKTRODENEINSATZ DES HERSTELLERS. DIE UNFALLVERHÜTUNGSVORSCHRIFTEN DES ARBEITGEBERS SIND EBENFALLS ZU BEACHTEN.

			
<ul style="list-style-type: none"> ● Keep your head out of fumes. ● Use ventilation or exhaust to remove fumes from breathing zone. 	<ul style="list-style-type: none"> ● Turn power off before servicing. 	<ul style="list-style-type: none"> ● Do not operate with panel open or guards off. 	WARNING
<ul style="list-style-type: none"> ● Los humos fuera de la zona de respiración. ● Mantenga la cabeza fuera de los humos. Utilice ventilación o aspiración para gases. 	<ul style="list-style-type: none"> ● Desconectar el cable de alimentación de poder de la máquina antes de iniciar cualquier servicio. 	<ul style="list-style-type: none"> ● No operar con panel abierto o guardas quitadas. 	Spanish AVISO DE PRECAUCION
<ul style="list-style-type: none"> ● Gardez la tête à l'écart des fumées. ● Utilisez un ventilateur ou un aspirateur pour ôter les fumées des zones de travail. 	<ul style="list-style-type: none"> ● Débranchez le courant avant l'entretien. 	<ul style="list-style-type: none"> ● N'opérez pas avec les panneaux ouverts ou avec les dispositifs de protection enlevés. 	French ATTENTION
<ul style="list-style-type: none"> ● Vermeiden Sie das Einatmen von Schweißrauch! ● Sorgen Sie für gute Be- und Entlüftung des Arbeitsplatzes! 	<ul style="list-style-type: none"> ● Strom vor Wartungsarbeiten abschalten! (Netzstrom völlig öffnen; Maschine anhalten!) 	<ul style="list-style-type: none"> ● Anlage nie ohne Schutzgehäuse oder Innenschutzverkleidung in Betrieb setzen! 	German WARNUNG
<ul style="list-style-type: none"> ● Mantenha seu rosto da fumaça. ● Use ventilação e exaustão para remover fumo da zona respiratória. 	<ul style="list-style-type: none"> ● Não opere com as tampas removidas. ● Desligue a corrente antes de fazer serviço. ● Não toque as partes elétricas nuas. 	<ul style="list-style-type: none"> ● Mantenha-se afastado das partes moventes. ● Não opere com os painéis abertos ou guardas removidas. 	Portuguese ATENÇÃO
<ul style="list-style-type: none"> ● ヒュームから頭を離すようにして下さい。 ● 換気や排煙に十分留意して下さい。 	<ul style="list-style-type: none"> ● メンテナンス・サービスに取りかかる際には、まず電源スイッチを必ず切って下さい。 	<ul style="list-style-type: none"> ● パネルやカバーを取り外したままで機械操作をしないで下さい。 	Japanese 注意事項
<ul style="list-style-type: none"> ● 頭部遠離煙霧。 ● 在呼吸區使用通風或排風器除煙。 	<ul style="list-style-type: none"> ● 維修前切斷電源。 	<ul style="list-style-type: none"> ● 儀表板打開或沒有安全罩時不準作業。 	Chinese 警告
<ul style="list-style-type: none"> ● 얼굴로부터 용접가스를 멀리하십시오. ● 호흡지역으로부터 용접가스를 제거하기 위해 가스제거기나 통풍기를 사용하십시오. 	<ul style="list-style-type: none"> ● 보수전에 전원을 차단하십시오. 	<ul style="list-style-type: none"> ● 판넬이 열린 상태로 작동치 마십시오. 	Korean 위험
<ul style="list-style-type: none"> ● ابعد رأسك بعيداً عن الدخان. ● استعمل التهوية أو جهاز ضغط الدخان للخارج لكي تبعد الدخان عن المنطقة التي تتنفس فيها. 	<ul style="list-style-type: none"> ● اقطع التيار الكهربائي قبل القيام بأية صيانة. 	<ul style="list-style-type: none"> ● لا تشغيل هذا الجهاز اذا كانت الاغطية الحديدية الواقية ليست عليه. 	Arabic تحذير

LEIA E COMPREENDA AS INSTRUÇÕES DO FABRICANTE PARA ESTE EQUIPAMENTO E AS PARTES DE USO, E SIGA AS PRÁTICAS DE SEGURANÇA DO EMPREGADOR.

使う機械や溶材のメーカーの指示書をよく読み、まず理解して下さい。そして貴社の安全規定に従って下さい。

請詳細閱讀並理解製造廠提供的說明以及應該使用的銀焊材料，並請遵守貴方的有關勞動保護規定。

이 제품에 동봉된 작업지침서를 숙지하시고 귀사의 작업자 안전수칙을 준수하시기 바랍니다.

اقرأ بتمعن وافهم تعليمات المصنع المنتج لهذه المعدات والمواد قبل استعمالها واتبع تعليمات الوقاية لصاحب العمل.



• World's Leader in Welding and Cutting Products •

• Sales and Service through Subsidiaries and Distributors Worldwide •

Cleveland, Ohio 44117-1199 U.S.A. TEL: 216.481.8100 FAX: 216.486.1751 WEB SITE: www.lincolnelectric.com