

HPI 700PC1 / HPI 700PS1

HIGH PURITY ONE-SIDED SUPPLY PANEL

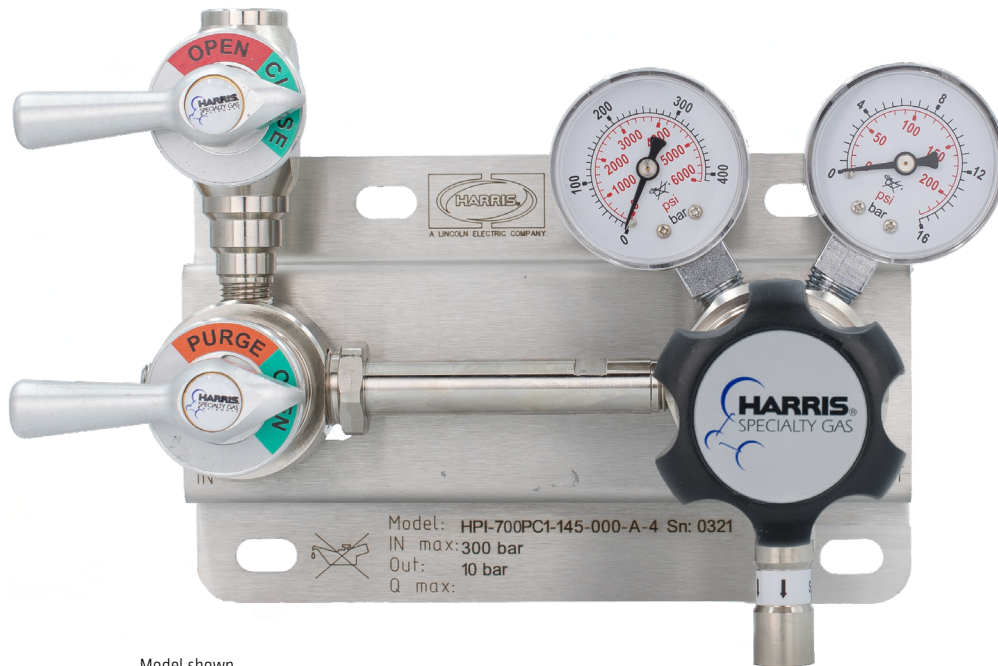

Model shown
PANEL,HPI-700PC1-145-000-A-4

KEY FEATURES

The HPI 700P1 series is a high purity gas supply panel. Manual adjustment of the regulator allow the user to set downstream pressure.

The system includes purge function. Designed for applications where a slight rise in delivery pressure from full to empty cylinder can be tolerated or as first stage of pressure reduction.

- Recommended gases purity levels up to grade 6.0 (99.9999)
- Stainless steel version applicable also for corrosive gases after prior confirmation of the material's compatibility*
- Wall mounting panel and brackets included
- Ready to install wall mounting panel
- Hastelloy®** diaphragm eliminates contamination from diffusion or outgassing
- Purge function and diaphragm shut-off valves for the best results
- Possible to connect 2 gas cylinders or gas cylinder and a gas for purging operation
- HPI 700PC1 – nickel-plated body, bonnet and fittings
- HPI 700PS1 – 316L stainless steel body and fittings
- 1×10^{-9} mbar l/s He inboard helium leak rate to maintain gas purity levels
- Inlet / outlet – 1/4" FNPT
- Maximum inlet pressure 300 bar (4350 psig), except for Acetylene: max. 25 bar (362 psig)
- External relief valve standard
- Cleaned for oxygen service

Applications »

Laboratory pressure control
Research sample systems gases
Component testing
Petrochemical industry
Emission monitoring systems
Controlled atmosphere
Service & test equipment



* Please check the material's compatibility in our Specialty Gas catalog.

** Hastelloy® is a registered trademark name of Haynes International, Inc



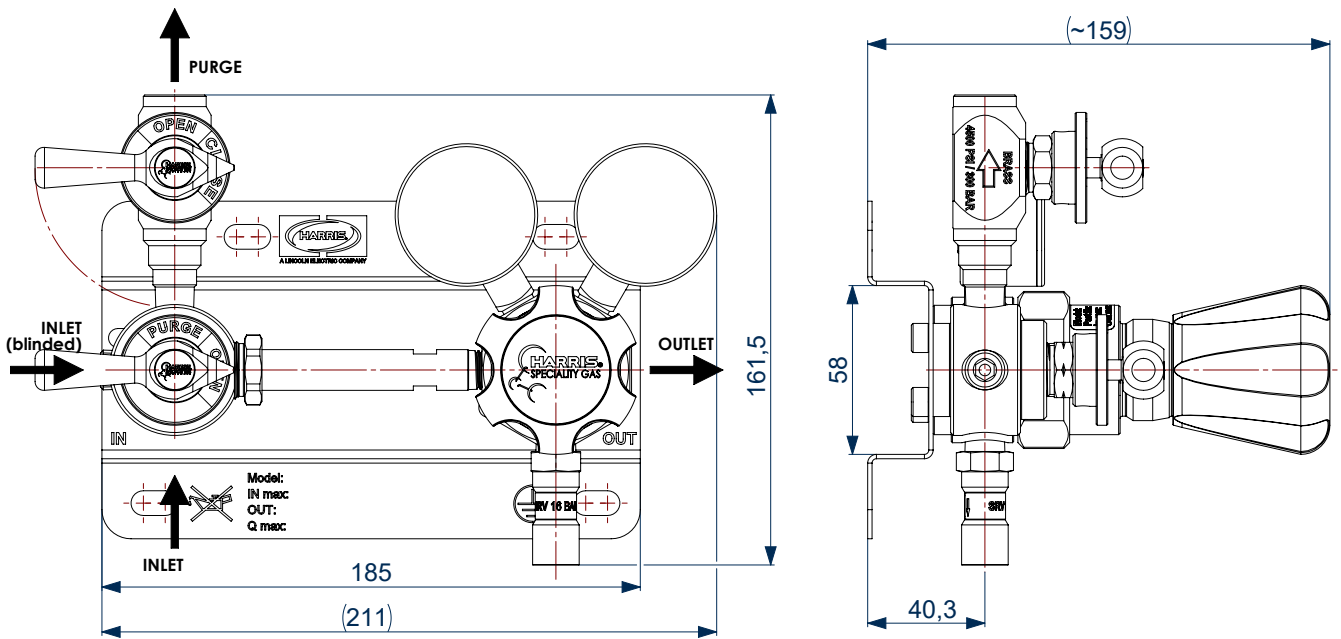

FLOW CHARTS

HPI 700P1

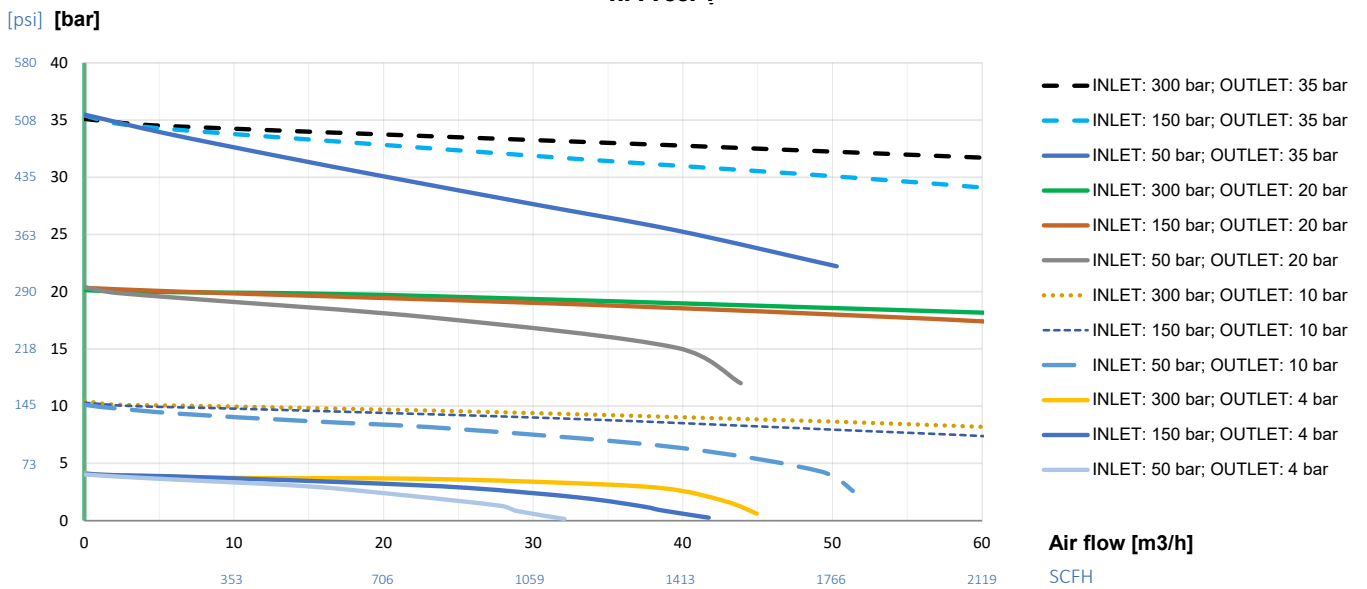

NOTES

CUSTOMER ASSISTANCE POLICY

The business of Lincoln Electric is manufacturing and selling high quality welding equipment, automated welding systems, consumables, and cutting equipment. Our challenge is to meet the needs of our customers, who are experts in their fields, and to exceed their expectations. On occasion, purchasers may ask Lincoln Electric for information or technical information about their use of our products. Our employees respond to inquiries to the best of their ability based on information and specifications provided to them by the customers and the knowledge they may have concerning the application. Our employees, however, are not in a position to verify the information provided or to evaluate the engineering requirements for the particular weldment, or to provide engineering advice in relation to a specific situation. Accordingly, Lincoln Electric does not warrant or guarantee or assume any liability with respect to such information or communications. Moreover, the provision of such information or technical information does not create, expand, or alter any warranty on our products. Any express or implied warranty that might arise from the information or technical information, including any implied warranty of merchantability or any warranty of fitness for any customers' particular purpose or any other equivalent or similar warranty is specifically disclaimed.

Lincoln Electric is a responsive manufacturer, but the definition of specifications, and the selection and use of specific products sold by Lincoln Electric is solely within the control of, and remains the sole responsibility of the customer. Many variables beyond the control of Lincoln Electric affect the results obtained in applying these types of fabrication methods and service requirements.



Contact Harris for pricing and custom configurations
+48 74 646 23 52
marketingharris@lincolnelectric.eu

Harris Products Group
ul. Strefowa 8, 58-200 Dzierzoniow, Poland
www.harrisproductsgroup.eu