



LINCOLN
ELECTRIC



AUTOMATION



Inrotech-Crawler





Robotic Welding Systems

Adaptive Multipass Welding | No Programming | Intuitive HMI

WHAT IS THE CHALLENGE?

Welding heavy, thick steel plates poses several challenges due to the material's properties, the required precision, and the demanding applications it often serves.



-  TIME/COST INTENSIVE
-  HIGH RISK OF ERRORS
-  LACK OF REPEATABLE WELDING QUALITY
-  HEALTH AND SAFETY RISKS

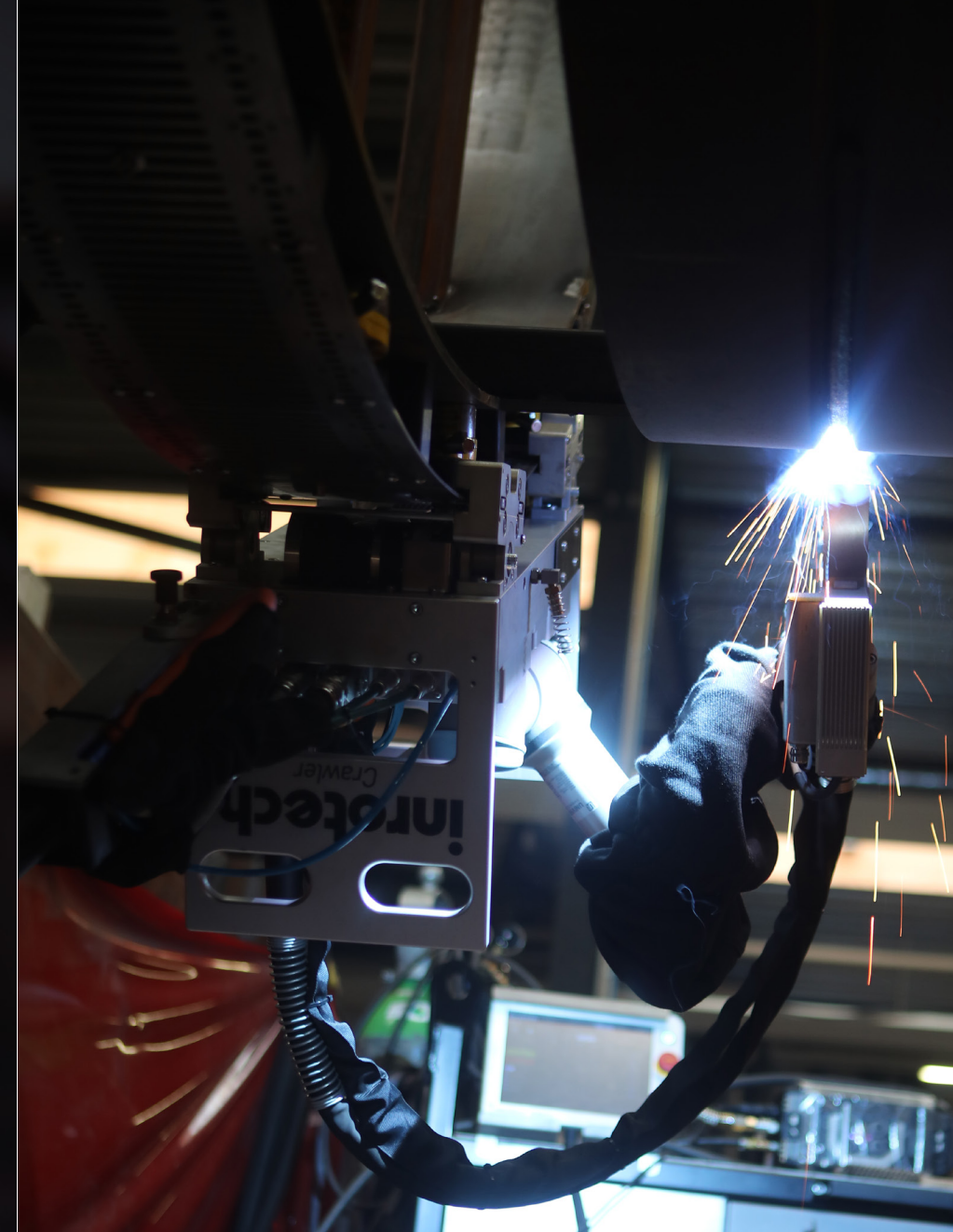

THIS IS OUR SOLUTION FOR YOU.

Multipass welding on large structures.

The versatile, mobile Inrotech-Crawler™ welding robot is designed for automated welding tasks in challenging environments. Its compact design allows it to navigate and weld efficiently on large structures, including ship hulls, tanks, etc. With advanced sensors and software, the Inrotech-Crawler system helps reduce manual labor and improve weld quality through high precision, consistency, and productivity.

-  CAN SAVE VALUABLE TIME
-  ONE-PERSON JOB
-  HELPS REDUCE ERRORS
-  IMPROVE SAFETY FOR OPERATORS



ENGINEERED FOR **EVERYBODY.**

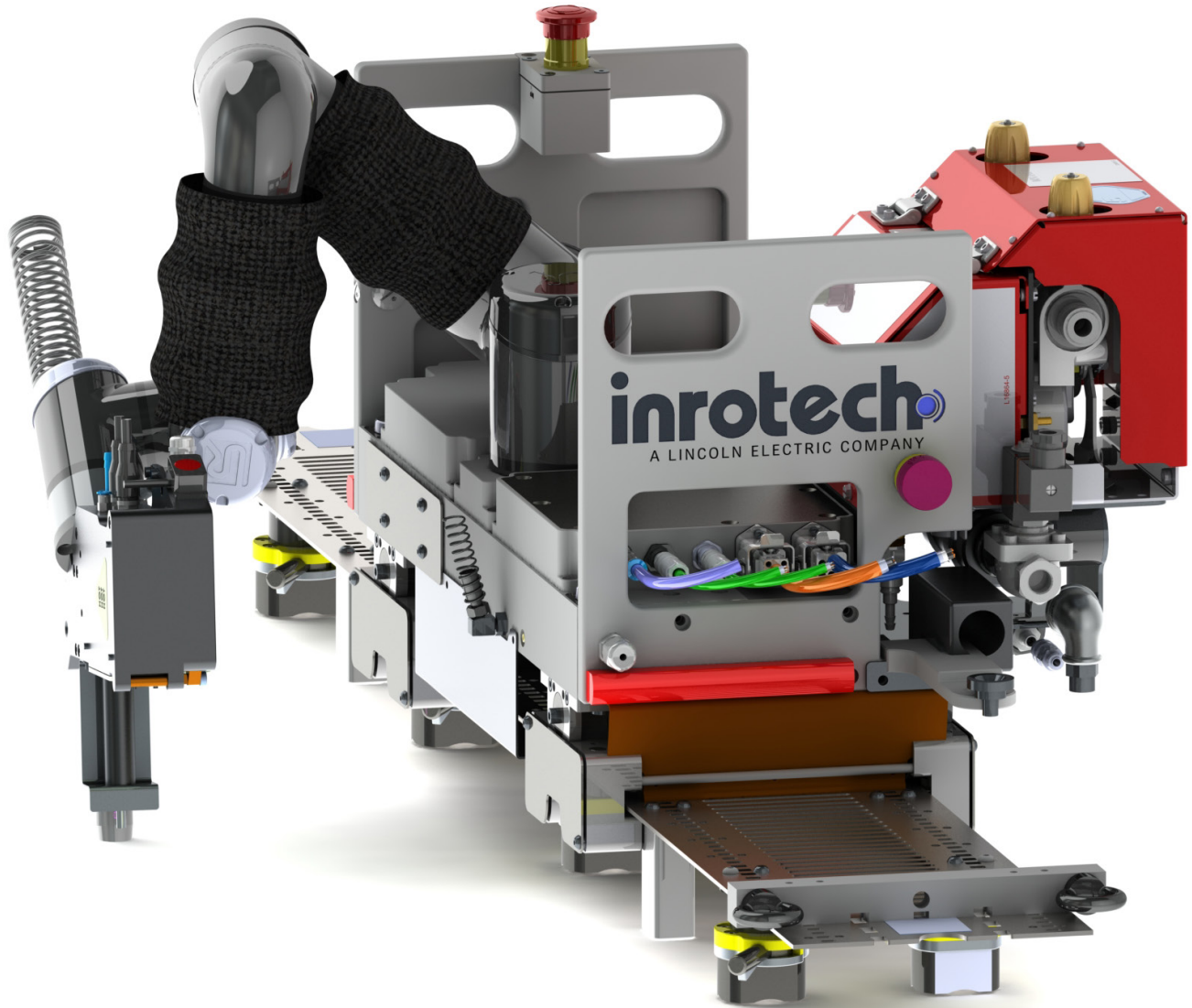

BRINGING VALUE TO THE OPERATION.

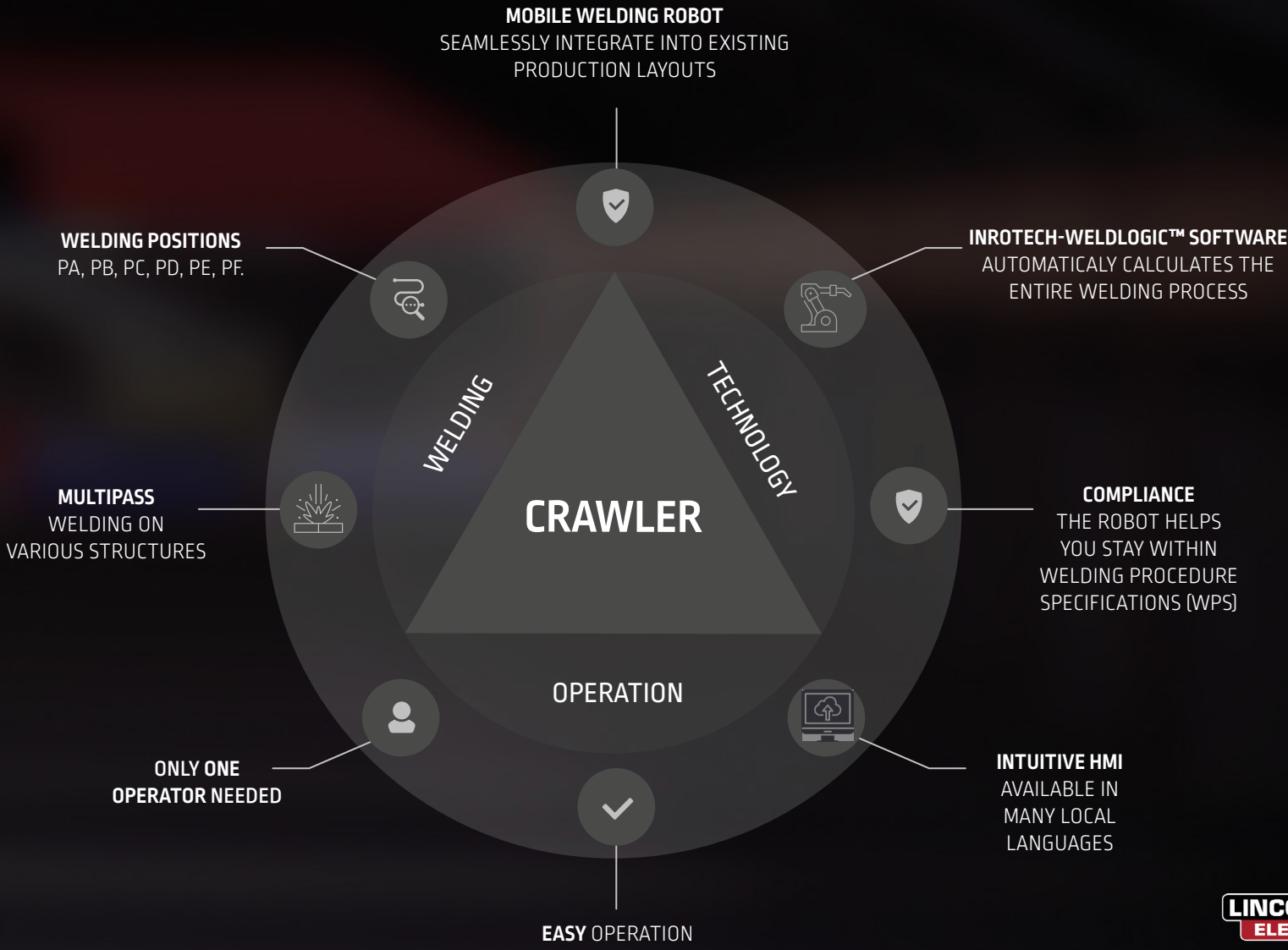

PROCESS OVERVIEW.

ADVANCED WELDING TECHNOLOGY

The Weldplanner feature generates a complete set of welding parameters for the whole weld, including speed, weaving amplitude, bead position, etc. If the groove geometry changes during the weld, due to deformation, Inrotech-WeldLogic software can detect this, and change the welding parameters accordingly.

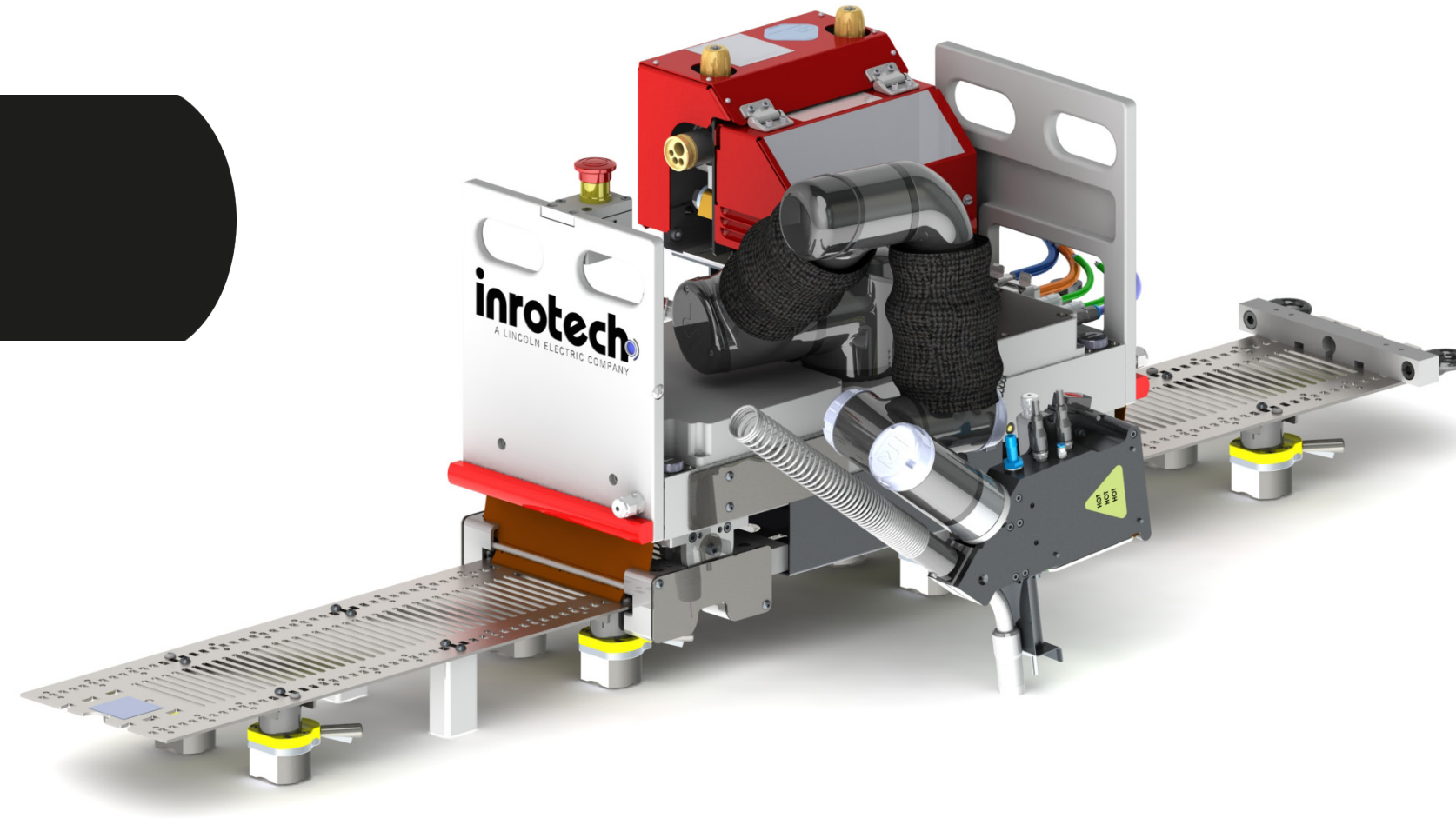

1 STARTING

The operator sets up the mobile robot, moves it to the object—eliminating the need to reposition structures—and sets up the job, all with just a few clicks.

2 SCANNING

The welding robot begins by scanning and analyzing the groove to be welded, determining both the welding position and the precise location of the groove.

3 WELDPLANNING

The software generates a complete set of welding parameters for the whole weld, including speed, weaving amplitude, bead position, amps, volts, and more. The built-in inclination sensor helps the robot identify the welding position and alter the parameters accordingly.

4 WELDING

While performing the weld, the software logs the actual welding parameters, such as welding speed, volts and amps, which serves as verification and documentation of the entire weld.

THE OPERATING SOFTWARE.



The general welding process is designed to require **as little input from the operator as possible.**

The Weldplanner automatically calculates the entire welding process: Number of passes and layers, location of each pass, and the appropriate welding parameters such as welding speed and weaving pattern.



Intuitive
weld planning



Reduce time in
large welds



Detect and correct for
deformations caused by
heat during the weld

The **Human Machine Interface (HMI)** is a Windows-based touch screen. The HMI enables the operator to access all the functionalities available in the Inrotech-Crawler system. The HMI itself is very simple and intuitive to use with commands being either icon based or in plain language.



AUTOMATE WITH THE INROTECH-WELDLOGIC TECHNOLOGY.



FLEXIBLE WELDING ROBOT

Reduce the need for repositioning large structures, which is often time-consuming and requires heavy lifting equipment. The robot can be quickly deployed to different work areas, reducing downtime and increasing welding efficiency.

HIGHER ARC TIME

Autonomous weld planning increases arc time compared to semi-automatic welding, resulting in greater efficiency and productivity.

RAIL SYSTEM

The rail system and the long cable connection offer unique versatility. As long as the substrate is magnetic, the rails can be installed in almost any position.

ADAPTIVE MULTIPASS WELDING: QUICK HITS



Adaptive multipass welding, primarily used for butt welding in various plate thickness due to its high versatility for tolerance and welding groove variation.



Automatically identifies the welding groove using a scanner and calculates the number of passes, location of each pass, welding speed and weaving pattern.



Specifically for welding of heavy plates and structures.



Operators can handle multiple units simultaneously. No programming is required.

A WELL-PROVEN TECHNOLOGY FOR **MULTIPASS WELDING** IN THE HEAVY FABRICATION INDUSTRY

SPECIFICATIONS

ROBOTICS	
Robot	UR3® CB3 Robot
Controller	UR3 CB3 Controller
External Axis	Servo motor
WELDING	
Power Source	Power Wave R450® Power Source
Wire Feeder	Lincoln Electric® AutoDrive® 4R100
Wire Feeder Booster	ABICOR BINZEL® SmartBooster
Water Cooler	Lincoln Electric Cool Arc® 50 Water Cooler
Welding Torch (Water-Cooled)	ABICOR BINZEL® AUT 501D Custom
Welding Wire Feed	Roll or drum*
WELDING PROCESS	
Welding Positions	PA, PB, PC, PD, PE, PF
Welding Wire	Flux-cored, metal-cored or solid wire**
Shielding Gas	Mixed Gas or CO2**
Groove Types	V-Groove, Half-V-Groove, Tulip*
TORCH CLEANING	
Spring	DINSE® torch cleaning station
SENSORS	
2D Line Scanner	Micro-Epsilon® 2D Line Scanner
Temperature Sensor	Yes**

WEIGHT OF COMPONENTS	
Carriage complete	60 kg
Cable pack 14 m (12 m efficient)	50 kg
Rail, 3000mm including 14 small and 1 large magnet	22 kg
Frame complete	415 kg
SUPPLIES	
Power	3 Phase 400 V + N + PE, 32 A, 50 Hz
Compressed Air	Yes
Internet Connection	LAN, WIFI or SIM-card
ENVIRONMENT	
Ambient Temperature Range	+5°C to 45°C
Humidity	90% RH or less. No dew, nor frost allowed
Environment	For indoor use only
COMMUNICATION	
Secure Access Gateway	Secomea® SiteManager
Human Machine Interface (HMI)	Android® tablet



WELDING SCOPE

THE INROTECH-CRAWLER SYSTEM IS A FLEXIBLE WELDING ROBOT THAT CAN HANDLE VARIOUS **MULTIPASS WELDING TASKS**. ITS PRIMARY USE IS FOR HEAVY MATERIAL, PLATES, LARGE PIPES, CURVED SUBSTRATES, AND OTHER ITEMS WHERE THERE ARE HIGH DEMANDS FOR WELD QUALITY.

- WELDING POSITIONS: PA, PB, PC, PD, PE, PF
- GROOVE DEPTHS: 20-80 MM
- GROOVE TYPES: V, HALF V AND TULIP GROOVES IN DIFFERENT ANGLES.

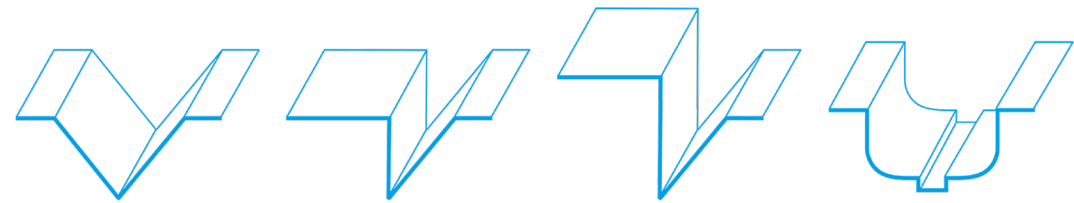

VERSATILITY IN WELDING POSITIONS

A mobile welding robot with all-position capability can seamlessly adapt to flat, horizontal, vertical, and overhead welding for precision across different joint configurations. This also leads to faster cycle times and higher throughput. The mobility of the robot allows it to be deployed quickly across multiple job sites or workstations, helping to reduce production bottlenecks.

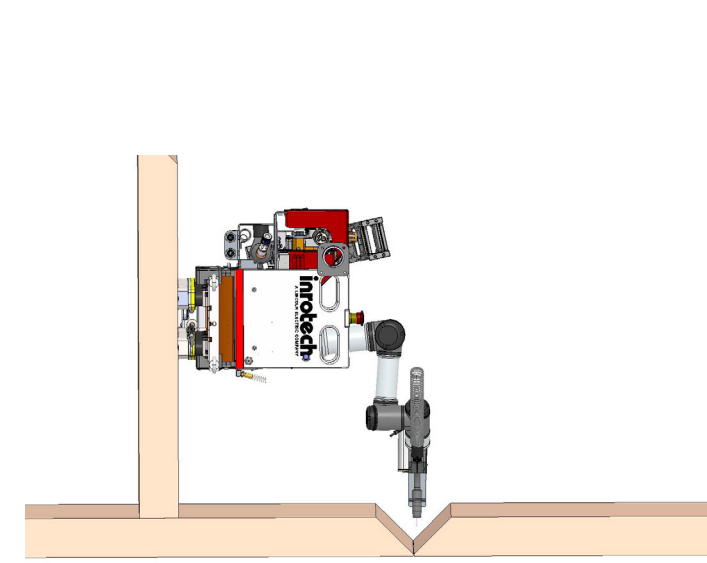

PA - FLAT POSITION
AWS: 1G

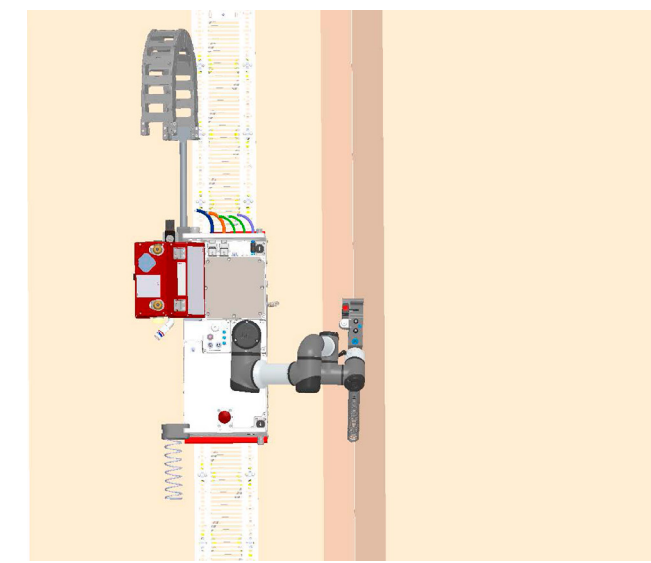

PF - VERTICAL UP POSITION
AWS: 3G, 3F, 5G

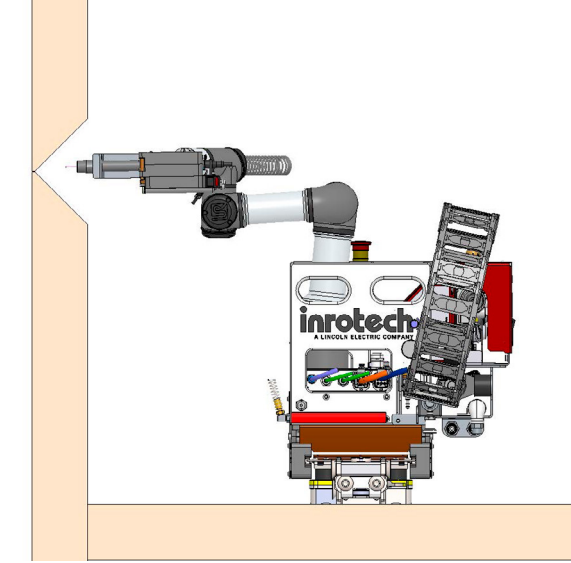

PC - HORIZONTAL POSITION

PC - HORIZONTAL POSITION
AWS: 2G,
(includes curved surfaces)

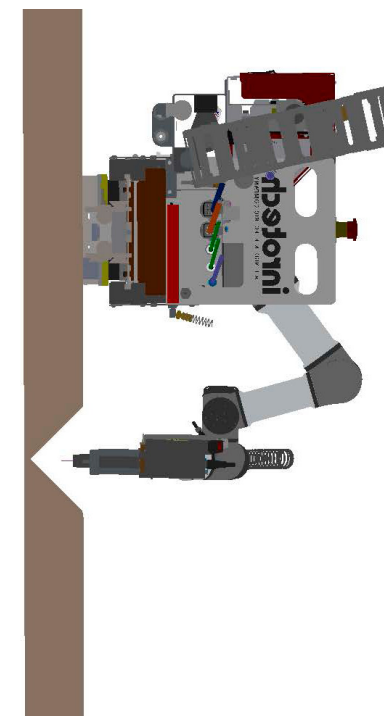

PE - OVERHEAD POSITION
AWS: 4G

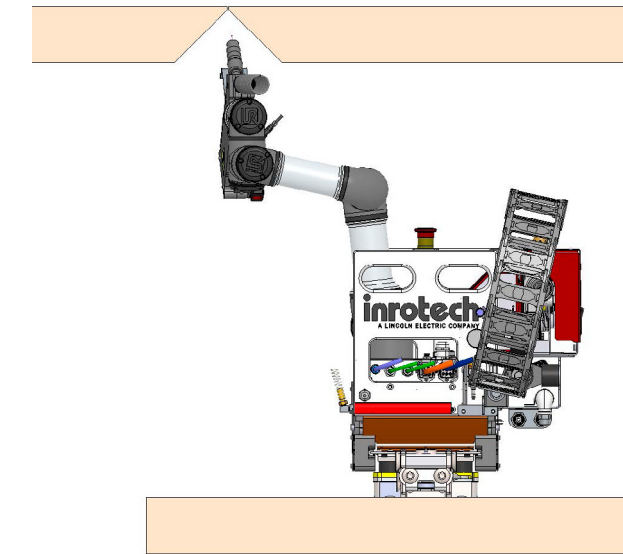

PA - FLAT POSITION
AWS: 1G

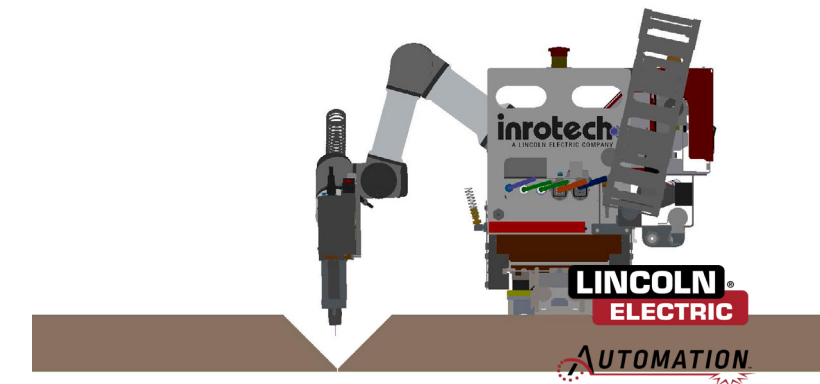

WORKING WITH THE INROTECH ECOSYSTEM



The Inrotech-Crawler system can easily be transported to different structures, reducing the need to move large or heavy workpieces. The system is ideal for large-scale projects such as shipbuilding, offshore platforms, and heavy steel structures where fixed welding stations are impractical.

OUR SOFTWARE

With the purchase of a Inrotech-Crawler system, we provide you with our in-house software: **Inrotech-WeldLogic technology is designed to make robotic welding simple, smarter, and more efficient by automating large welding processes with minimal operator input.**

OPTIMIZED WORKFLOW

Define start and stop points and press "start". The robot automatically identifies the welding groove by means of a line scanner and automatically calculates the number of passes, location of each pass, welding speed and weaving pattern; no matter the position or plate thickness.



THE VALUE OF WORKING WITH LINCOLN ELECTRIC AUTOMATION

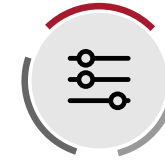

FIT INTO EXISTING PRODUCTION

A mobile welding robot can adapt to different workpieces and environments, making it ideal for shipbuilding, heavy steel structures, and offshore construction.



INNOVATIVE TECHNOLOGY

Leveraging the latest in welding technology, we deliver solutions that are not only effective but also scalable and future-proof.



EXPERT TEAM

Our team of experts has years of experience and a wealth of knowledge in welding industries, helping you receive the best possible guidance and support.



COMPREHENSIVE SUPPORT

From initial consultation to implementation and ongoing support, we are with you every step of the way.

„CAN I HAVE A LOOK AT THE SYSTEM IN-PERSON ?“ **YES.**

See for yourself on-site! Get in touch with our sales team to schedule a live demo near you. [Book a meeting here.](#)



AUTOMATION **SERVICE & SUPPORT.**

With every machine bought from Lincoln Electric Automation, you get the peace of mind that our expert engineers are available to support your operations.



WE PROVIDE FULL SUPPORT **WORLDWIDE**

- ✓ Fully trained field service engineers
- ✓ Fast spare parts fulfillment
- ✓ Online courses and trainings

JOIN THE INNOVATIVE WORLD OF **INROTECH MACHINES!**

Solutions that fit into your existing manufacturing.

WE COLLABORATE WITH OUR CUSTOMERS TO DEFINE **THE RIGHT SYSTEM FOR THEIR NEEDS.**

We pay attention to:

- ✓ Given surroundings and onsite conditions
- ✓ Your future expansion plans
- ✓ Process implementation

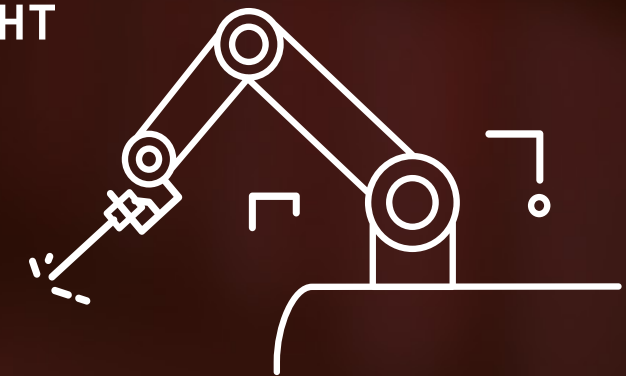

TAKE EFFICIENCY TO THE NEXT LEVEL.

inrotech
Crawler

LINCOLN
ELECTRIC

AUTOMATION

Publication LEA-063025PH-01
© Lincoln Global Inc. All Rights Reserved
<https://www.lincolnelectric.com/automation>
All trademarks and registered trademarks are the property of
their respective owners.

Inrotech A/S

A Lincoln Electric Company
Tietgens Boulevard 26,
5220, Odense SØ
Phone: +45 6616 4100
E-mail: info@inrotech.com
www.inrotech.com

The Lincoln Electric Company
22221 Saint Clair Avenue
Cleveland OH 44117-1199 USA

