



# STATIFLEX<sup>®</sup> COMPLETE 4, 8 & 12

COMPACT FUME EXTRACTION SYSTEM



# Statiflex® Complete Filtration System

## Quality, Self-Cleaning Filtration Solutions

Fume extraction is one of the most important responsibilities of automated manufacturing and fabrication companies involved in any type of automated welding. But most large industrial fume extraction systems take up a lot of space, which limits the footprint that your facility could use for other purposes. At Lincoln Electric, we understand that both fume extraction and floor space are very important to any facility with automated cells. That is why we have developed the Statiflex Complete 4, 8, and 12 filter bank models. The Statiflex Complete is a reduced-footprint fan/filtration unit combination designed with robotic welding and plasma cutting systems in mind. The self-cleaning 4-filter, 8-filter and 12-filter configurations can provide extraction capacity for just about any automated system equipped with a modular or fabricated hood. Extract and filter out weld fume while saving valuable floor space with Lincoln Electric's all-new Statiflex Complete fume extraction systems.



Statiflex Complete 4 Front View



Statiflex Complete 4 Side View With Control Panel



Statiflex Complete 4 Back View

## Fume Extraction Made Easy

### Quiet Operation

The fan compartment of the Statiflex Complete is lined with premium quality sound absorbing material to reduce operating noise. The silencer on the exhaust side of the fan reduces airflow noise as well, resulting in a quietly operating fume extraction system.

### Intelligent Fan Control Technology

The Statiflex Complete system is equipped with a variable speed starter to fine-tune the extraction airflow to the requirements of the application. The variable speed starter also regulates the fan speed based on filter loading to maintain consistent airflow. This adjustment capability maximizes fume extraction, conserves energy and extends the equipment life, which ultimately results in capital expenditure savings.

### Automatic Cleaning

The Statiflex Complete is capable of monitoring any pressure drops across the filters. If detected above a pre-set value, the system knows that filters are dirty and automatically starts the cleaning process. The particulate is blown off of the filters by controlled blasts of compressed air, which then causes the dust to fall into the dust bin where the harmful material can be extracted.

### Quick and Simple Installation

- Shipped in four pieces over two pallets (8 & 12), and three pieces on one pallet (4 only)
- Locate and secure base module to floor (8 & 12 only)
- Stack upper filter module on base module
- Position silencer and dust bin
- Connect power and compressed air
- Connect to extraction hood

#### Processes »

Stick, TIG, MIG, Flux-Cored, Plasma Cutting, Arc Gouging, Grinding<sup>Ⓜ</sup>

#### Applications »

- Automation processes
- Robotic booths
- General fabrication
- Heavy fabrication
- Indoor manufacturing facilities
- Welding education/training facilities

#### Input »



#### Product Number »

Contact Lincoln Electric's Environmental group for a consultation at 1-888-935-3878, ext. 4

<sup>Ⓜ</sup> Not suitable for use when grinding Aluminum, Magnesium or other explosive materials.

# STATIFLEX COMPLETE 4 »

## Unit Includes

- » **Statiflex Complete 4 Which Holds 4 Filter Cartridges and Is Self Cleaning.**
  - Power Specifications » 460V, 575V (optional), 3-Phase Power
  - Frequency » 50/60 Hz
  - Compressed Air » 5 bar/65 psi, 2650 CFM @ 6 in. sp
- » **4 HP Fan Motor**
  - 460V/3-/50-60 Hz, 3520 RPM, IP55, 2500 SCFM
- » **Control Panel Lincoln Smart Connect™ for Filter Cleaning**
  - Pressure control cleaning
  - Digital pressure measuring
- » **Variable Speed Starter for 4 HP Motor**
  - 5 Hp, 460V and 575V (optional) +/-10%, 50/60 Hz, 3-, ip20/NEMA 1
- » **Filter Options**
  - Merv 11 Filter Cartridge » featuring spun bound polyester media
  - Merv 16 Filter Cartridge, NANO » featuring NANO fibers
  - Merv 16 Filter Cartridge, PTFE » featuring thermal bonded PTFE membrane
- » **Optional Spark Guardian** for applications welding on oily parts which improves thermal protection.
- » **Optional Transformer Kit** available for 575V applications

### Operational Changes Due To Lincoln Smart Connect

- Quick & simple field installation
- Optional Bluetooth android based interface available for the customer to access set points, fan speed etc.
- Remote operation interface via Lincoln Smart Connect I/O allows startup and monitoring of the filter unit from a robotic welding cell



Statiflex Complete 4  
(AD1326-14)

## Dimensions

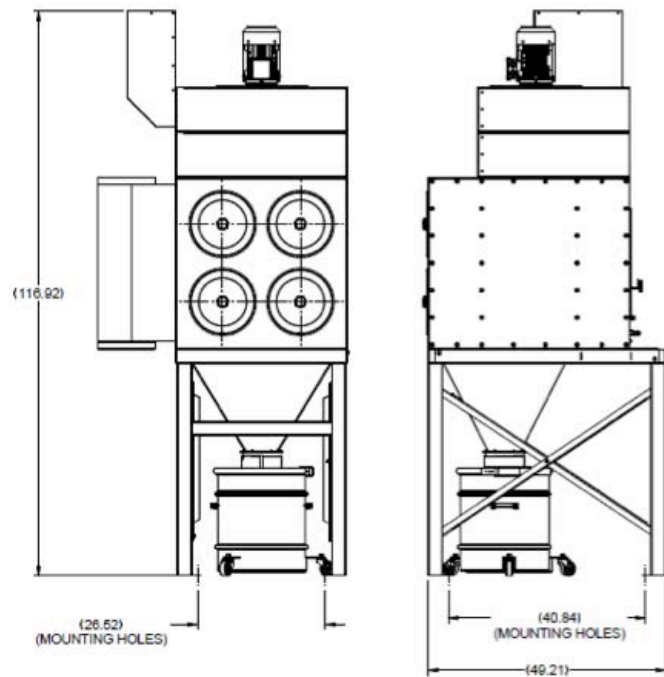
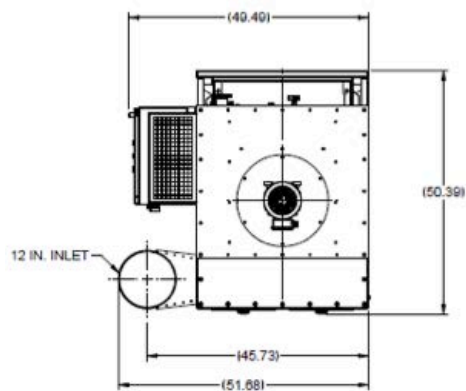

## Shipping Details

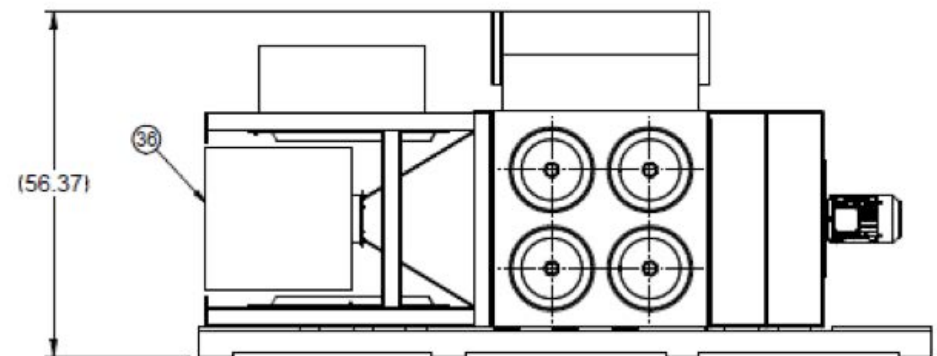
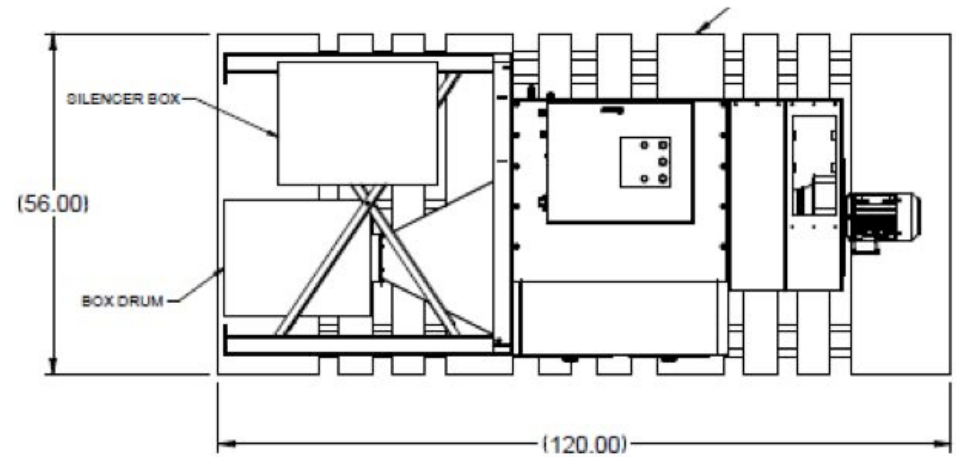



# STATIFLEX COMPLETE 8 »

## Unit Includes

- » **Statiflex Complete 8 Which Holds 8 Filter Cartridges and Is Self Cleaning**
  - Power Specifications » 460V, 575V (optional), 3-Phase Power
  - Frequency » 50/60 Hz
  - Compressed Air » 5 bar/65 psi, 4200 CFM @ 7 in. sp
- » **10 HP Fan Motor**
  - 460V/3~/50-60 Hz, 3300 RPM, IP55, 2500 SCFM
- » **Control Panel Lincoln Smart Connect for Filter Cleaning**
  - Pressure control cleaning
  - Digital pressure measuring
- » **Variable Speed Starter for 10 HP Motor**
  - 10Hp, 400-480V/3~/50-60Hz/16A
- » **Filter Options**
  - Merv 11 Filter Cartridge » featuring spun bound polyester media
  - Merv 16 Filter Cartridge, NANO » featuring NANO fibers
  - Merv 16 Filter Cartridge, PTFE » featuring thermal bonded PTFE membrane
- » **Optional Spark Guardian** for applications with an increased fire risk
- » **Optional Transformer Kit** available for 575V applications

### Operational Changes Due To Lincoln Smart Connect

- Quick & simple field installation
- Optional Bluetooth android based interface available for the customer to access set points, fan speed etc.
- Remote operation interface via Lincoln Smart Connect I/O allows startup and monitoring of the filter unit from a robotic welding cell



Statiflex Complete 8  
(AD1326-15)

## Dimensions

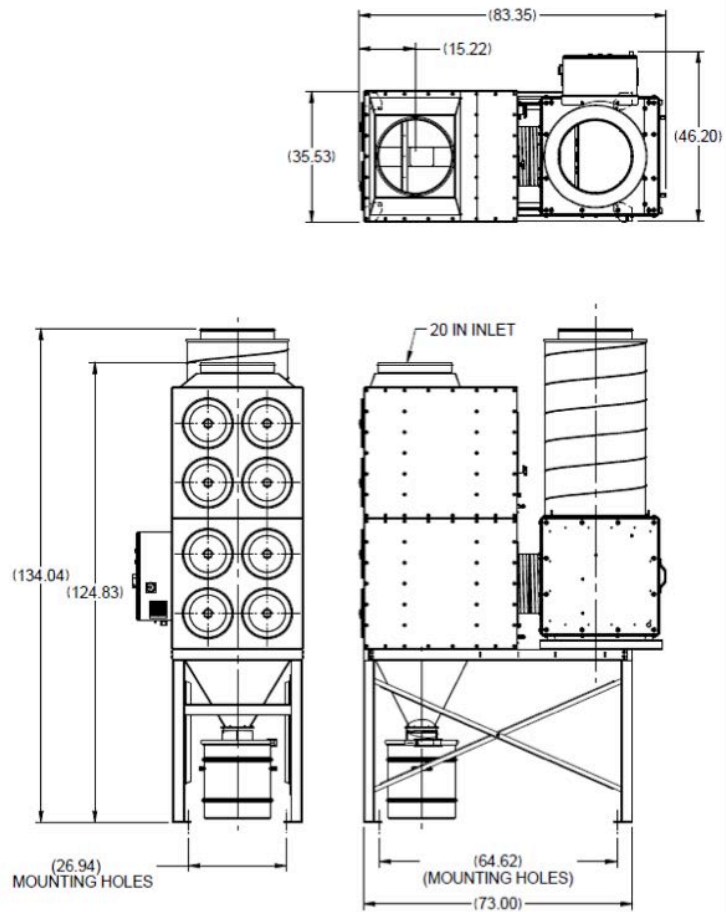

## Shipping Details

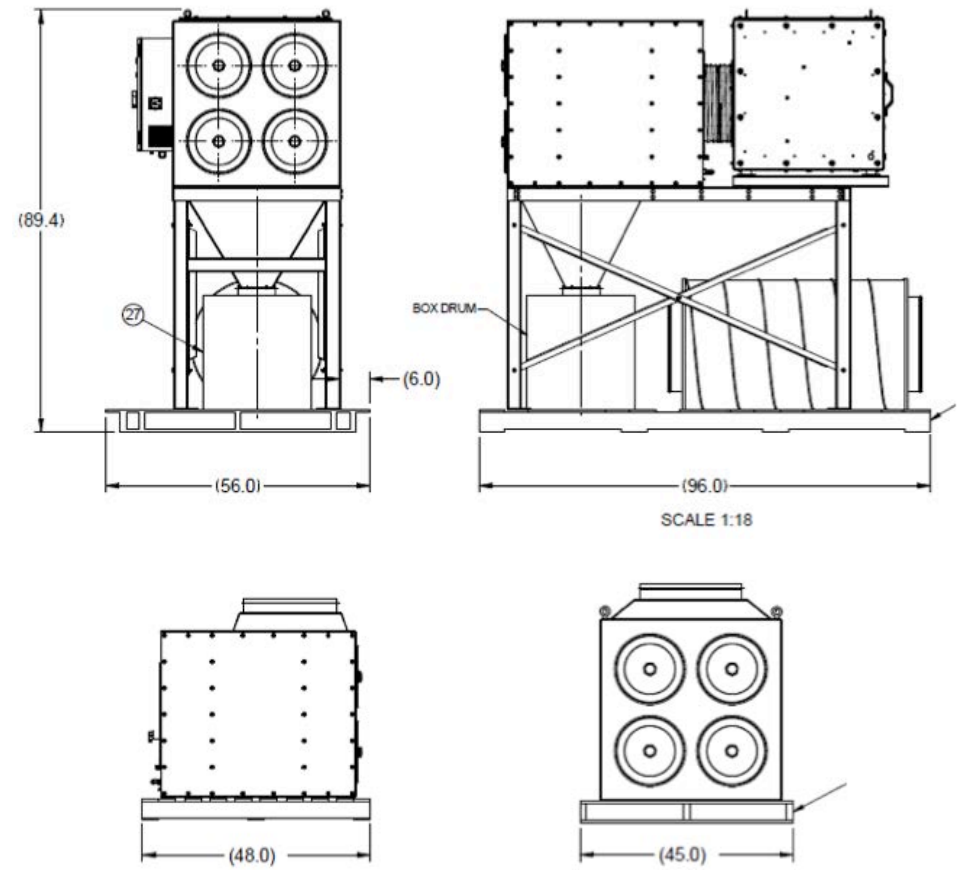

# STATIFLEX COMPLETE 12 »

## Unit Includes

- » **Statiflex Complete 12 Which Holds 12 Filter Cartridges and Is Self Cleaning**
  - Power Specifications » 460V, 575V (optional), 3-Phase Power
  - Frequency » 50/60 Hz
  - Compressed Air » 5 bar/65 psi, 4200 CFM @ 7 in. sp
- » **10 HP Fan Motor**
  - 460V/3~/50-60 Hz, 3300 RPM, IP55, 2500 SCFM
- » **Control Panel Lincoln Smart Connect for Filter Cleaning**
  - Pressure control cleaning
  - Digital pressure measuring
- » **Variable Speed Starter for 10 HP Motor**
  - 10Hp, 400-480V/3~/50-60Hz/16A
- » **Filter Options**
  - Merv 11 Filter Cartridge » featuring spun bound polyester media
  - Merv 16 Filter Cartridge, NANO » featuring NANO fibers
  - Merv 16 Filter Cartridge, PTFE » featuring thermal bonded PTFE membrane
- » **Optional Spark Guardian** for applications with an increased fire risk
- » **Optional Transformer Kit** available for 575V applications

### Operational Changes Due To Lincoln Smart Connect

- Quick & simple field installation
- Optional Bluetooth android based interface available for the customer to access set points, fan speed etc.
- Remote operation interface via Lincoln Smart Connect I/O allows startup and monitoring of the filter unit from a robotic welding cell



Statiflex Complete 12  
(AD1326-16)



## Dimensions

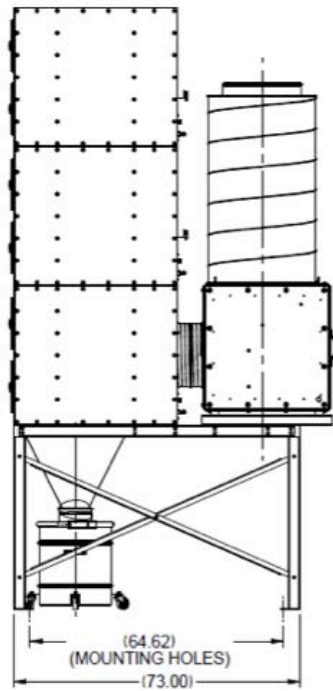
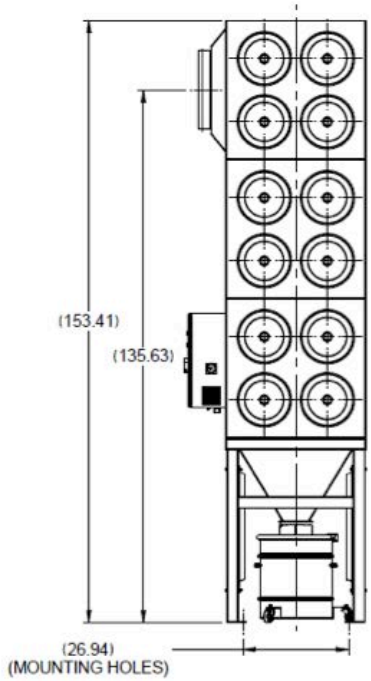
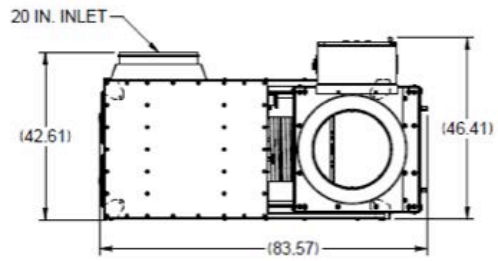

## Shipping Details

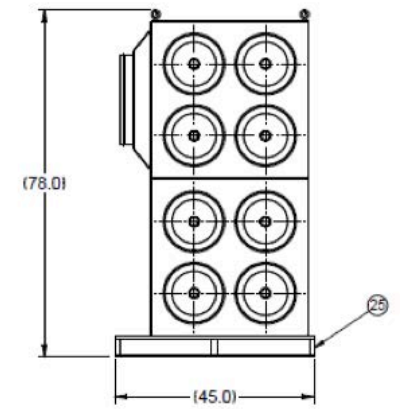
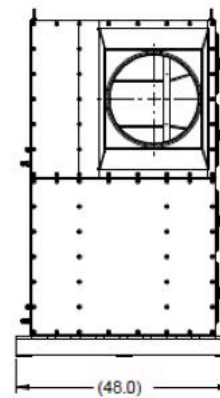
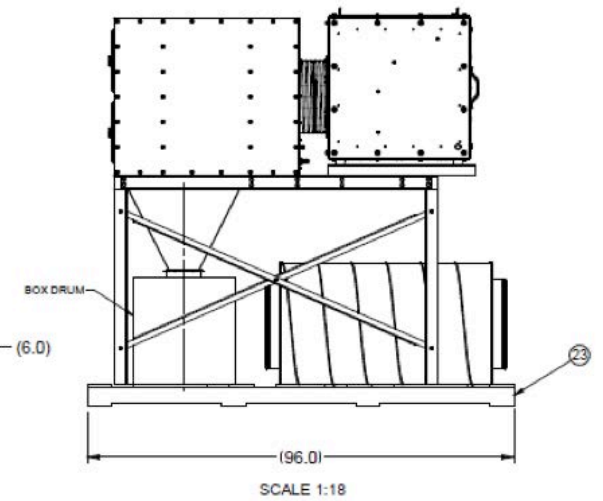
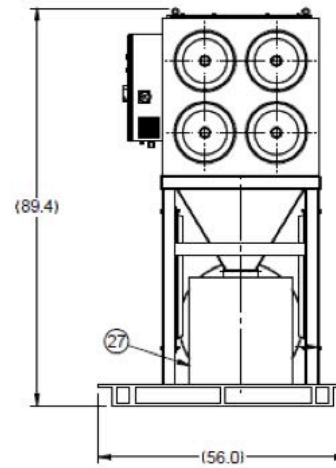

# Airflow »

## 4-Filter Cartridge Model

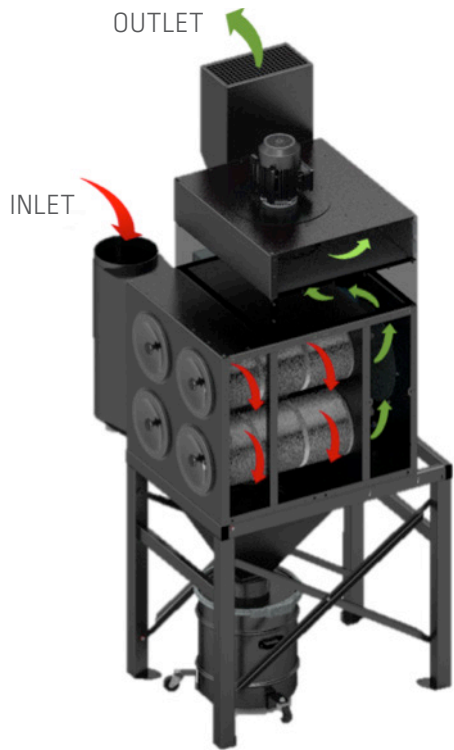

AD1326-14

## 8-Filter Cartridge Model

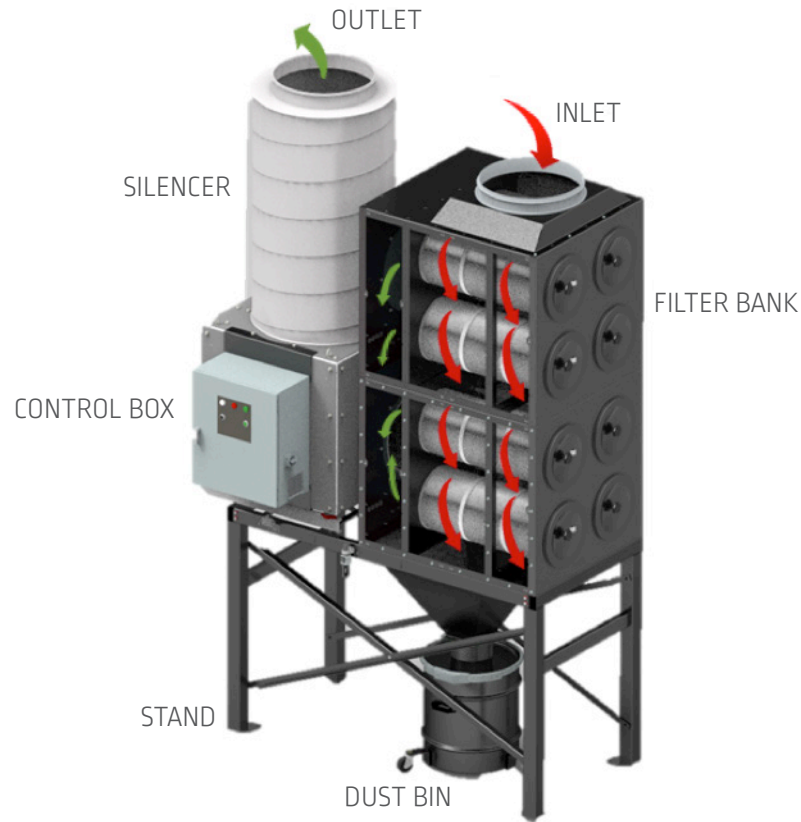

AD1326-15

## 12-Filter Cartridge Model

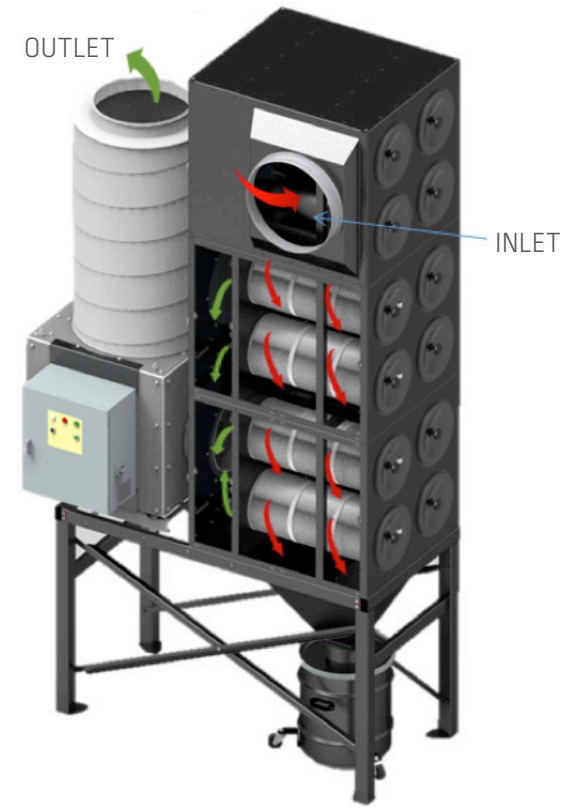

AD1326-16



## Hoods »

---



Statiflex Complete 8  
with Modular Hood Attachment



Robotic Welding Cell  
with Fabricated Hood

## Spare Parts List »

Item	Description	Part Number
01	ENV Gasket	9SS31228-189
02	Compressed Air Regulator	9SS23385-108
03	Star Knob M12	9SFC0000101387
04	Cartridge Cover	9SFC0069002050
05	M12 Hex Nut	9ST14815-9
06	M12 Plain Washer	9SS9262-1
07	M12 Rubber Washer	9ST11135-1
08	End Cover Dia 20 in.	9SFC0000101043
09	1/4" Drain Valve	9SS23385-142
10	Threaded Reducer	9SS30229-14
11	Push-In T-Fitting	9SS30229-15
12	Push-In Fitting Bulk Head	9SS30229-16
13	Plug	9ST10397-28
14	SFB-Dustbin; Drum Lid; Lever Lock; Flex Duct	9SS31228-273
15	SFB Drum Trolley; Castor	9SFC0000100869
16	SFB Cover Plate	9SFC0000101458
17	Cover Plate SFB - 4	9SFC0000100933
18	Cover Plate Side	9SFC0000101456
19	Flex Duct	9SS31256-9
20	SFB Join Kit-M8 Stud; M8 Flange Nut; ENV Gasket 80 ft	9SL17480-2
21	Rear Plate Flange Bolt 1/4-20X.625H	9SCF000420
22	12 mm Tubing	9SFC0000101496
23	24 VDC Solenoid Coil	9SS31228-398

Item	Description	Part Number
24	Control Logic Smartwire-DT	9SS23199-203
25	60 Watt Power Supply	9SS31228-540
26	CC Fuse for Drive	9ST10728-82
27	CC Fuse for Power Supply	9ST10728-83
28	Smart Connect Led White Contact Block	9SS21130-111
29	Smart Connect Led Red Contact Block	9SS21130-104
30	Smart Connect Led Green Contact Block	9SS21130-107
31	Smart Connect Contact Block	9SS21130-105
32	Variable Speed Starter 10hp DE1 VFD	AD1283-68
33	DT Communication Module	9SS23199-200
34	Smart Connect DT I/O 2X Digital	9SS31228-508
35	Smart Connect DT I/O 4X Digital	9SS23199-205
36	Flush, Green, PB Operator	9SS21130-109
37	Flush, Black, PB Operator	9SS21130-108
38	Flush Pilot Light, Operator White	9SS21130-110
39	Flush Pilot Light, Operator Red	9SS21130-103
40	Flush Pilot Light, Operator Green	9SS21130-106
41	32A 3-Phase Disconnect	9SS22553-9
42	Smart Connect DT Ip 67 I/O Device Splitter Pin 2 M12	9SS23394-101
43	Cable Assembly 5C, M12, 2 ft	9SS31228-499
44	Cable Assembly 5C, M12, 1 m	9SS23394-102
45	Cable Assembly 5C, M12 1M Single End	9SS23394-100
46	Smart Connect DT Bus Termination Module	9SS23199-204
47	Cable Assembly 5C, M12 20m	9SS31228-623

#### CUSTOMER ASSISTANCE POLICY

The business of The Lincoln Electric Company® is manufacturing and selling high quality welding equipment, consumables, and cutting equipment. Our challenge is to meet the needs of our customers and to exceed their expectations. On occasion, purchasers may ask Lincoln Electric for information or advice about their use of our products. Our employees respond to inquiries to the best of their ability based on information provided to them by the customers and the knowledge they may have concerning the application. Our employees, however, are not in a position to verify the information provided or to evaluate the engineering requirements for the particular weldment. Accordingly, Lincoln Electric does not warrant or guarantee or assume any liability with respect to such information or advice. Moreover, the provision of such information or advice does not create, expand, or alter any warranty on our products. Any express or implied warranty that might arise from the information or advice, including any implied warranty of merchantability or any warranty of fitness for any customers' particular purpose is specifically disclaimed.

Lincoln Electric is a responsive manufacturer, but the selection and use of specific products sold by Lincoln Electric is solely within the control of, and remains the sole responsibility of the customer. Many variables beyond the control of Lincoln Electric affect the results obtained in applying these types of fabrication methods and service requirements.

Subject to Change – This information is accurate to the best of our knowledge at the time of printing. Please refer to [www.lincolnelectric.com](http://www.lincolnelectric.com) for any updated information.