

FAB-PAK CDZ

ROBOTIC WELDING SYSTEMS



Renders are for reference only
Image subject to change

FAB-PAK CDZ (COMPACT DUAL ZONE) ROBOTIC WELDING SYSTEM

The Fab-Pak® family of pre-engineered robotic welding systems from Lincoln Electric Automation™ enhance part production by helping to improve productivity, quality, and safety. The Fab-Pak CDZ standard robotic welding system is ideal for small- to medium-sized parts that need reorientation.

SYSTEM INCLUDES

- Power Wave® R450 power source
- AutoDrive® 4R100 wire feeder
- Magnum® PRO robotic torch
- Power Ream® II torch maintenance unit
- ABB® welding robot
- Robot basic software package
- Wire mesh panels with weld curtains
- Push button control

KEY FEATURES

- Shipped completely assembled
- Minimal installation

INDUSTRY

- High-mix, low-volume manufacturing

BENEFITS

- Full welding capabilities with a small robot arm and system footprint
- ANSI/RIA safety compliant

OPTIONS AVAILABLE

- Water-cooled torch
- LaserTouch (requires water-cooled torch)
- TouchSense
- Thru Arc Seam Tracking
- Touchscreen HMI
- Prism® fume extraction system
- Headstock positioner in each zone
- Tooling tables and beams
- Virtual or in-person training

CONTACT LINCOLN ELECTRIC AUTOMATION - CLEVELAND



22221 St. Clair Ave
Euclid, OH 44117



+1 (216) 383-2959



lincolnelectric.com

Publication LEA-041223TM1-03

© Lincoln Global Inc. All Rights Reserved. All trademarks and registered trademarks are the property of their respective owners.
www.lincolnelectric.com/automation



RECOMMENDED OPTION - FUME EXTRACTION

Shown:
Fab-Pak CDZ-FT
with Prism Exhaust
Hood and Prism
Compact

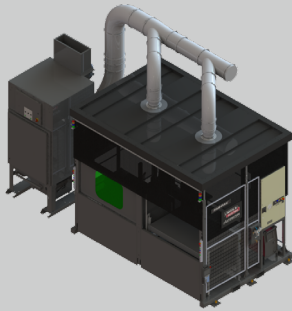

Prism® systems are specifically designed to remove fumes generated in robotic welding environments. The systems include the Prism exhaust hood, a Prism central extraction unit, and appropriate ducting.

Lincoln Electric can help you meet your fume filtration goals; whether that is to meet OSHA or insurance requirements, retain workers, or simply to have a filtered welding environment.

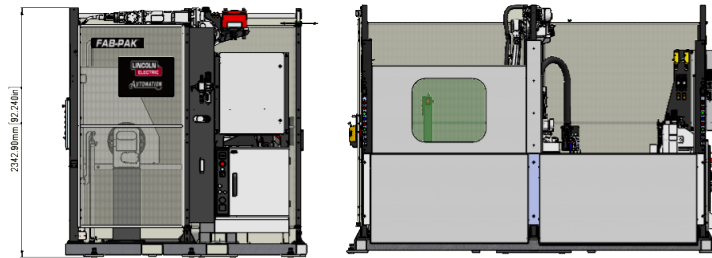
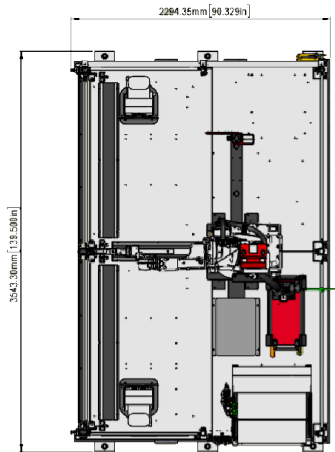

Fab-Pak CDZ-HS with ABB robot

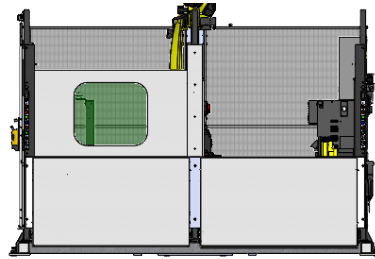
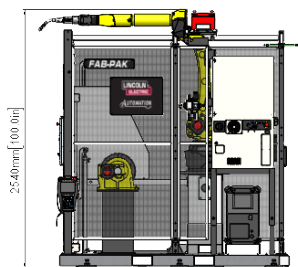

Fab-Pak CDZ-FT with FANUC robot

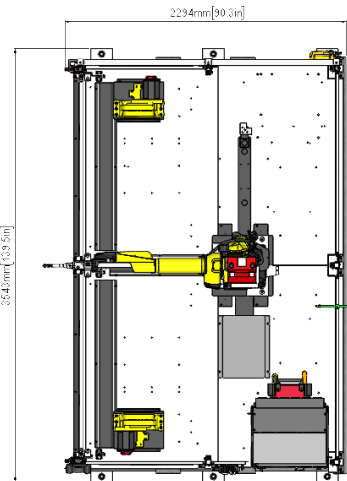

PRODUCT SPECIFICATIONS

Product Number	Model Name	Positioner Capacity (kg)	Span (mm)	Swing (mm)	Wire Feeder	Robot Arm	Qty of Robots
AD2504	CDZ-FT	500	N/A	N/A	4R100	ABB or FANUC	1
	CDZ-HS	500	1000	750	4R100	ABB or FANUC	1

Important Note: Changes from recommended motor sizing, payload, duty cycles, cable routing, weld grounding (if applicable), other system specifications (i.e. servo parameters, controller stop parameter), and/or modifications may affect cycle times and overall performance. User assumes all responsibility for proper rigging, installation, and machine setting alignments of product(s). Manufacturer's warranty is void to the extent any failure caused by improper installation, modification, or operation by customer.

CUSTOMER ASSISTANCE POLICY

The business of Lincoln Electric is manufacturing and selling high quality welding equipment, automated welding systems, consumables, and cutting equipment. Our challenge is to meet the needs of our customers, who are experts in their fields, and to exceed their expectations. On occasion, purchasers may ask Lincoln Electric for information or technical information about their use of our products. Our employees respond to inquiries to the best of their ability based on information and specifications provided to them by the customers and the knowledge they may have concerning the application. Our employees, however, are not in a position to verify the information provided or to evaluate the engineering requirements for the particular weldment, or to provide engineering advice in relation to a specific situation or application. Accordingly, Lincoln Electric does not warrant or guarantee or assume any liability with respect to such information or communications. Moreover, the provision of such information or technical information does not create, expand, or alter any warranty on our products. Any express or implied warranty that might arise from the information or technical information, including any implied warranty of merchantability or any warranty of fitness for any customers' particular purpose or any other equivalent or similar warranty is specifically disclaimed.

Lincoln Electric is a responsive manufacturer, but the definition of specifications, and the selection and use of specific products sold by Lincoln Electric is solely within the control of, and remains the sole responsibility of the customer. Many variables beyond the control of Lincoln Electric affect the results obtained in applying these types of fabrication methods and service requirements.

THE LINCOLN ELECTRIC COMPANY
22801 Saint Clair Avenue · Cleveland, OH · 44117 · U.S.A.
Phone: +1 216.481.8100 · www.lincolnelectric.com