

ASPECT™ 300

For use with machines having code numbers: 52125-50595



SERVICE MANUAL



LINCOLN ELECTRIC EUROPE
www.lincolnelectric.eu

INDEX OF CONTENTS

TECHNICAL SPECIFICATIONS AND ACCESSORIES	3
SAFETY	4
INSTALLATION AND OPERATOR INSTRUCTIONS	5
MAINTENANCE	25
MAJOR COMPONENTS LOCATION	27
THEORY OF OPERATION	28
INPUT	29
INVERTER-OUTPUT TRANSFORMER AND OUTPUT DIODE PCB.....	30
OUTPUT BOARD, IGBT BOARD AND HF BOARD	31
CONTROL AND USER INTERFACE BOARD	32
TROUBLESHOOTING AND REPAIR SECTION	36
HOW TO USE TROUBLESHOOTING GUIDE	37
CASE COVER REMOVAL AND DC BUS CAPACITOR DISCHARGE PROCEDURE.....	40
DC BUS CAPACITORS DISCHARGE PROCEDURE	42
EMC FILTER BOARD TEST.....	43
INPUT RECTIFIER TEST.....	45
BUCK/BOOST BOARD TEST	47
INPUT POWER BOARD TEST	50
INPUT CONTROL BOARD TEST.....	53
INVERTER BOARD RESISTANCE TEST.....	57
INVERTER BOARD VOLTAGE TEST.....	59
OUTPUT BOARD TEST.....	61
OUTPUT DIODE BOARD RESISTANCE TEST.....	64
IGBT BOARD RESISTANCE TEST	67
HF BOARD TEST.....	70
CONTROL BOARD AND USER INTERFACE TEST.....	73
GAS SOLENOID TEST	77
DISASSEMBLY OPERATIONS.....	79
RETEST AFTER REPAIR	98
CALIBRATION PROCEDURE	99
ELECTRICAL SCHEMATICS	100
NOTE.....	102

TECHNICAL SPECIFICATIONS AND ACCESSORIES

ASPECT™ 300

INPUT							
Input Voltage U_1					EMC Class	Frequency	
230 - 400Vac \pm 15%					A	50/60 Hz	
Input Line	Mode	35%	60%	100%	Input Amperes I_{1max}	PFmax	
230Vac	STICK	10.3kW	8.8 kW	7kW	27.4 A	0.94	
	TIG DC	8.8kW	6.4 kW	4.8kW			
	STICK AC	9.6kW	8.3kW	6.9kW			
	TIG AC	8.2kW	6.2kW	4.8kW			
400Vac	STICK	10.4kW	8.7 kW	7kW	16.5A	0.91	
	TIG DC	8.8kW	6.3 kW	4.8kW			
	STICK AC	9.6kW	8.4 kW	6.8kW			
	TIG AC	8.2kW	6.2 kW	4.8kW			
RATED OUTPUT							
		Output Current I_2 Duty Cycle at % (based on a 10 min. period)			Output Voltage U_2 Duty Cycle at % (based on a 10 min. period)		
Input Line	Mode	35%	60%	100%	35%	60%	100%
230Vac/400Vac 3ph	STICK DC	270A	240A	200A	30.8V	29.6V	28V
	TIG DC	300A	240A	200A	22V	19.6V	18V
	STICK AC	270A	240A	200A	30.8V	29.6V	28V
	TIG AC	300A	240A	200A	22V	19.6V	18V
OUTPUT RANGE							
Welding Current Range				Open Circuit Voltage OCV U_0			
2 – 300A				90 Vdc			
RECOMMENDED INPUT CABLE AND FUSE SIZES							
Fuse (time delayed) or Circuit Breaker Size				Input Power Cable			
16A@400Vac – 32A@ 230Vac				4x4mm ²			
DIMENSIONS AND WEIGHT							
Height		Width		Length		Net Weight	
535 mm		301 mm		632 mm		43 Kg	
Operating Temperature		Storage Temperature		Operating Humidity (t=20°C)		Protection Degree	
-10°C to +40°C		-25°C to 55°C		Not Applicable		IP23	

Accessories

KIT-250A-35-5M	Cable kit 250A – 35mm ² – 5m
KIT-300A-50-5M	Cable kit 300A – 50mm ² – 5m
GRD-300A—50-xM	Ground cable 300A – 50mm ² – 5/10m
K10513-26-xM	Tig Torch LT 26G – 180A – 4/8m
K10513-18-xM	Tig Torch LT 18W – 320A – 4/8m
K10513-18SC-xM	Tig Torch LT 18SC W – 400A – 4/8m
K10513-20-xM	Tig Torch LT 20W – 220A – 4/8m
K10095-1-15M	Remote Control – 15m
K14105-1	Water Cooler COOLARC 46
K10420-1	Coolant Acorox (2x5l)
K14129-1	Cart TPX





SAFETY



WARNING

This equipment must be used by qualified personnel. Be sure that all installation, operation, maintenance and repair procedures are performed only by qualified person. Read and understand this manual before operating this equipment. Failure to follow the instructions in this manual could cause serious personal injury, loss of life, or damage to this equipment. Read and understand the following explanations of the warning symbols. Lincoln Electric is not responsible for damages caused by improper installation, improper care or abnormal operation.

	WARNING: This symbol indicates that instructions must be followed to avoid serious personal injury, loss of life, or damage to this equipment. Protect yourself and others from possible serious injury or death.
	READ AND UNDERSTAND INSTRUCTIONS: Read and understand this manual before operating this equipment. Arc welding can be hazardous. Failure to follow the instructions in this manual could cause serious personal injury, loss of life, or damage to this equipment.
	ELECTRIC SHOCK CAN KILL: Welding equipment generates high voltages. Do not touch the electrode, work clamp, or connected work pieces when this equipment is on. Insulate yourself from the electrode, work clamp, and connected work pieces.
	ELECTRICALLY POWERED EQUIPMENT: Turn off input power using the disconnect switch at the fuse box before working on this equipment. Ground this equipment in accordance with local electrical regulations.
	ELECTRICALLY POWERED EQUIPMENT: Regularly inspect the input, electrode, and work clamp cables. If any insulation damage exists replace the cable immediately. Do not place the electrode holder directly on the welding table or any other surface in contact with the work clamp to avoid the risk of accidental arc ignition.
	ELECTRIC AND MAGNETIC FIELDS MAY BE DANGEROUS: Electric current flowing through any conductor creates electric and magnetic fields (EMF). EMF fields may interfere with some pacemakers, and welders having a pacemaker shall consult their physician before operating this equipment.
	CE COMPLIANCE: This equipment complies with the European Community Directives.
	ARTIFICIAL OPTICAL RADIATION: According with the requirements in 2006/25/EC Directive and EN 12198 Standard, the equipment is a category 2. It makes mandatory the adoption of Personal Protective Equipments (PPE) having filter with a protection degree up to a maximum of 15, as required by EN169 Standard.
	FUMES AND GASES CAN BE DANGEROUS: Welding may produce fumes and gases hazardous to health. Avoid breathing these fumes and gases. To avoid these dangers the operator must use enough ventilation or exhaust to keep fumes and gases away from the breathing zone.
	ARC RAYS CAN BURN: Use a shield with the proper filter and cover plates to protect your eyes from sparks and the rays of the arc when welding or observing. Use suitable clothing made from durable flame-resistant material to protect you skin and that of your helpers. Protect other nearby personnel with suitable, non-flammable screening and warn them not to watch the arc nor expose themselves to the arc.
	WELDING SPARKS CAN CAUSE FIRE OR EXPLOSION: Remove fire hazards from the welding area and have a fire extinguisher readily available. Welding sparks and hot materials from the welding process can easily go through small cracks and openings to adjacent areas. Do not weld on any tanks, drums, containers, or material until the proper steps have been taken to insure that no flammable or toxic vapors will be present. Never operate this equipment when flammable gases, vapors or liquid combustibles are present.
	WELDED MATERIALS CAN BURN: Welding generates a large amount of heat. Hot surfaces and materials in work area can cause serious burns. Use gloves and pliers when touching or moving materials in the work area.

	SAFETY MARK: This equipment is suitable for supplying power for welding operations carried out in an environment with increased hazard of electric shock.
	EQUIPMENT WEIGHT OVER 30kg: Move this equipment with care and with the help of another person. Lifting may be dangerous for your physical health.
	CYLINDER MAY EXPLODE IF DAMAGED: Use only compressed gas cylinders containing the correct shielding gas for the process used and properly operating regulators designed for the gas and pressure used. Always keep cylinders in an upright position securely chained to a fixed support. Do not move or transport gas cylinders with the protection cap removed. Do not allow the electrode, electrode holder, work clamp or any other electrically live part to touch a gas cylinder. Gas cylinders must be located away from areas where they may be subjected to physical damage or the welding process including sparks and heat sources.
	CAUTION: The high frequency used for contact-free ignition with TIG (GTAW) welding, can interfere with the operation of insufficiently shielded computer equipment, EDP centers and industrial robots, even causing complete system breakdown. TIG (GTAW) welding may interfere with electronic telephone networks and with radio and TV reception.
	NOISE APPEARES DURING WELDING CAN BE HARMFUL: Welding arc can cause noise with high level of 85dB for 8-hour week day. Welders operating welding machines are obligated to wear the proper ear protectors /appendix No. 2 for the Decree of the Secretary of Labor and Social Policy from 17.06 1998 – Dz.U. No. 79 pos. 513/. According to the Decree the Secretary of Health and Social Welfare from 09.07.1996 /Dz.U. No. 68 pos. 194/, employers are obligated to carry examinations and measurements of health harmful factors.

The manufacturer reserves the right to make changes and/or improvements in design without upgrade at the same time the operator's manual.

Installation and Operator Instructions

General description

Aspect™ 300ACDC machine is designated to perform SMAW and GTAW welding process in DC and AC current.

Unit is designed mainly to satisfy GTAW requestes in both DC and AC mode: thanks an advance menu options both beginners and experts welder can adjust welding parameters to have the best welding performances.

Following paragraphs will show how to access to the menu and the parameters tha can be set.

Read this entire section before installation or operation of the machine.

Location and Environment

This machine will operate in harsh environments. However, it is important that simple preventative measures are followed to assure long life and reliable operation.

- Do not place or operate this machine on a surface with an incline greater than 15° from horizontal.
- Do not use this machine for pipe thawing.
- This machine must be located where there is free circulation of clean air without restrictions for air movement to and from the air vents. Do not cover the machine with paper, cloth or rags when switched on.
- Dirt and dust that can be drawn into the machine should be kept to a minimum.
- This machine has a protection rating of IP23. Keep it dry when possible and do not place it on wet ground or in puddles.
- Locate the machine away from radio controlled

machinery. Normal operation may adversely affect the operation of nearby radio controlled machinery, which may result in injury or equipment damage. Read the section on electromagnetic compatibility in this manual.

- Do not operate in areas with an ambient temperature greater than 40°C.

Input Supply Connection

Check the input voltage, phase, and frequency supplied to this machine before turning it on. The allowable input voltage is indicated in the technical specification section of this manual and on the rating plate of the machine. Be sure that the machine is grounded.

Make sure the amount of power available from the input connection is adequate for normal operation of the machine. The fuse rating and cable sizes are both indicated in the "Technical Specification" section of this manual.

The machines are designed to operate on engine driven generators as long as the auxiliary can supply adequate voltage, frequency and power as indicated in the "Technical Specification" section of this manual. The auxiliary supply of the generator must also meet the following conditions:

400Vac 3 phases:

- Vac peak voltage: below 670V
- Vac frequency: in the range of 50 and 60Hz
- RMS voltage of the AC waveform: 400Vac ± 15%

230Vac 3 phases:



- Vac peak voltage: below 410V

- Vac frequency: in the range of 50 and 60Hz
- RMS voltage of the AC waveform: 230Vac ± 15%

It is important to check these conditions because many engine driven generators produce high voltage spikes. Operation of this machine on engine driven generators not conforming to these conditions is not recommended and may damage the machine.

Output Connections

A quick disconnect system using Twist-Mate™ cable plugs is used for the welding cable connections. Refer to the following sections for more information on connecting the machine for operation of stick welding (MMA) or TIG welding (GTAW).

	Quick Disconnect: Torch (for MMA and GTAW process) output connector for the welding circuit.
	Quick Disconnect: workpiece output connector for the welding circuit.

Stick Welding (MMA)

This machine does not include a MMA welding kit cables, but may be purchased separately. Refer to the accessories section for more information.

First determine the proper electrode polarity for the electrode to be used. Consult the electrode data for this information. Then connect the output cables to the output terminals of the machine for the selected polarity. Shown here is the connection method for torch.

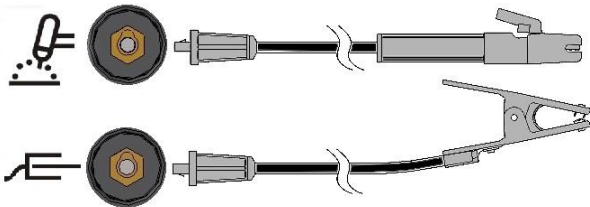

Connect the electrode cable to the torch terminal and the work clamp to the work piece terminal. Insert the connector with the key lining up with the keyway and rotate approximately ¼ turn clockwise. Do not over tighten.

Polarity for Stick can be selected between (DC+, DC-, AC) by front panel push button and menu, see following.

TIG Welding (GTAW)

This machine does not include a TIG torch necessary for TIG welding, but one may be purchased separately. Refer to the accessories section for more information.

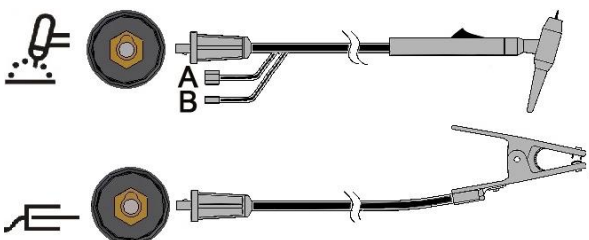

Connect the torch cable to the torch terminal of the machine and the work clamp to the work piece terminal. Insert the connector with the key lining up with the

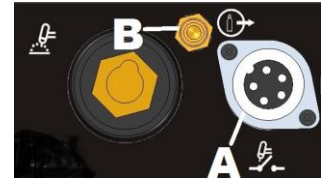

keyway and rotate approximately ¼ turn clockwise. Do not over tighten. Finally, connect the gas hose from the TIG torch to the gas connector (B) on the front of the machine. If necessary, an extra gas connector for the fitting on the front of the machine is included in the package. Next, connect the fitting on the back of the machine to a gas regulator on the cylinder of gas to be used. The required fittings are included in the package. Connect the TIG torch trigger to the trigger connector (A) on the front of the machine.

TIG Welding with a Water Cooled Torch

A cooling unit can be applied to the Machine:

- COOLARC-46

If a Coolarc unit listed above is connected to the Machine, it will be automatically turned ON and OFF in order to ensure the torch cooling. When Stick welding mode is used the cooler will be OFF.

This machine does not include a cooled TIG torch, but one may be purchased separately. Refer to the accessories section for more information.

WARNING

The Machine is provided with an electrical connection for the Coolarc unit on its rear side. This socket is ONLY for the connection of the Coolarc unit listed above.

WARNING

Before connecting the cooler unit to the Machine and operate, read and understand the Instruction Manual supplied with the cooling unit.

WARNING

Connect and disconnect the cooler with the unit switched OFF.

Remote Control Connection

Refer to the accessories section for a list of remote controls. If a remote control is used, it will be connected to the remote connector on the front of the machine.

The machine will automatically detect the remote control, turn on the REMOTE LED, and switch to remote control mode. More information on this mode of operation will be given in the next section.



WIRELESS

Unit can manage also a remote device wireless. To accept this part an auxiliary supply connector to supply wireless device is

put on the front of the unit. This supply connector is protect by a plastic cover. See accessory section for details on wireless part number.

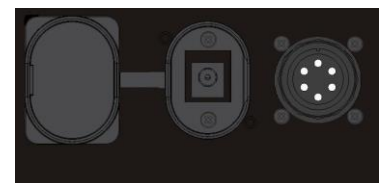

Rear Panel

- Power Switch:** It turns ON / OFF the input power to the machine.
- Input cable:** Connect it to the mains.
- Fan:** Do not obstruct or filter the fan inlet. The "F.A.N." (Fan As Needed) feature automatically turns OFF/ON the fan. When the Machine is turned ON the fan is turned ON only for the startup time (few seconds). The fan will start with welding operations and will continue to run whenever the Machine is welding. If the Machine doesn't weld for more than 10minutes, it will go in Green Mode.

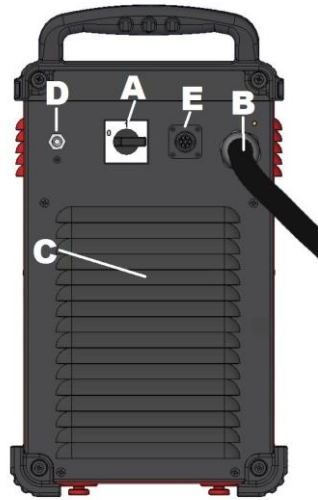

Green Mode

The Green Mode is a feature that puts the machine in a stand-by condition:

- The output is disabled
- The fans are speed down
- Only the Power ON LED remains ON.
- Display show the dash char

This reduces the amount of dirt that can be drawn inside the Machine and the power consumption.

To restore the Machine restart to weld or push the TIG trigger or push any buttons in the front panel or turn the encoder knob.

NOTE: If a COOLARC TIG torch cooling unit is connected to the machine, it will be turned ON/OFF by the Green Mode feature based also on COOL option. See Menu SYS section for more details.

Idle Mode

After 30 minutes without welding the machine will enter a deep low power mode. It will shut down all indicators: only Power ON Led is blinking.

To restore the Machine push the trigger or push any buttons in the front panel or turn the encoder Exit procedure will take 6-7s: after this time the unit is ready to weld.

- Gas Inlet:** Connector for the TIG shielding gas. Use the supplied connector to connect the machine to the gas source line. The gas source must have a pressure regulator and flow gage installed.
- Power supply socket for Coolarc:** 400Vac socket. Connect here the Coolarc cooling unit.

Controls and Operational Features

Machine Start-Up:

When the machine is turned ON an auto-test is executed.

The Machine is ready to operate when on the Front Control Panel lights up the "Power ON" LED, the "A" LED (placed on the middle of the synoptic) with one of the LED of the Welding "MODE" command. This is the minimum condition: depending by the welding selection others LEDs may be ON.

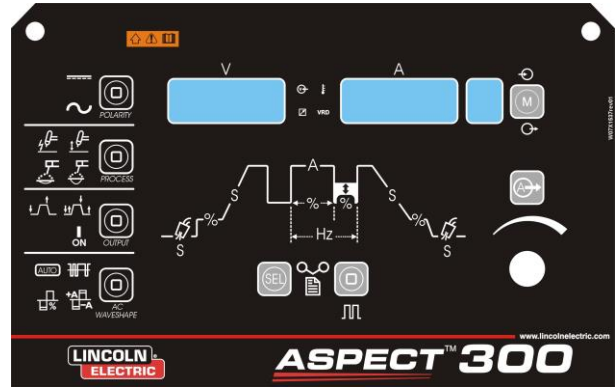

Front Panel Indicators and Controls

Power ON LED:



This LED blinks during the machine start-up or during restart after idle mode and lights up steadily when the machine is ready to operate.

If the Input Voltage Overage protection becomes active, the Power ON LED starts blinking and an error code is shown on the displays. The machine restarts automatically when the Input Voltage returns in the correct range. For further detail read the Error Codes and Troubleshooting section.

If the trigger is pushed before the unit is ready to weld, or after a weld is completed in GTAW mode, the Power ON LED will blink at a fast rate. Release the trigger to restore normal operation.

Remote LED:



This indicator will turn on when a Remote command is connected to the machine via the remote control connector.

If a Remote command is connected to the Machine, the Output Current knob operates in two different modes: STICK and TIG:

- **STICK mode:** with a Remote command connected the output of the machine is ON. A Remote Amptrol or Pedal are allowed (trigger is ignored).



Connecting the Remote command excludes the Output Current Knob of the Machine's user interface. Through the Remote command is available the full Output Current Range.

- **TIG mode:** in Local and remote mode the output of the machine is OFF. A Trigger is necessary to enable the output.

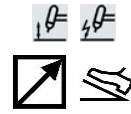

The Output Current range selectable from the Remote command depends by the Machine's user interface Output Current Knob. Eg.: if the Output Current is set to 100A with the Machine's user interface Output Current Knob, the Remote command will adjust the Output Current from a minimum of 5A to a maximum of 100A.

Remote Pedal: For a correct use, the "Menu GTAW" and "Menu SYS" must be enabled in the setup menu:

- 2-step sequence is automatically selected
- Upslope / Downslope ramps and Restart are disabled.
- Spot, Bi-Level and 4-step functions aren't selectable

(Normal operation is restored when the Remote command is disconnected.)

Thermal LED:



This indicator will turn on when the machine is overheated and the output has been disabled. This normally occurs when the duty cycle of the machine has been exceeded. Leave the machine on to allow the internal components to cool. When the indicator turns off, normal operation is again possible.

VRD LED (enabled on Australian Machines only):



This machine is provided by VRD (Voltage Reduction Device) function: this reduces the voltage at the output leads.

The VRD function is enabled by factory default only on machines that meet the AS 1674.2 Australian Standards. (C-Tick logo "C" on/near the Rating Plate applied on the machine).

The VRD LED is ON when the Output Voltage is below 12V with the Machine at idle (no welding time).

For others machines (CE & USA) this function is abled into Menu SYS.

Polarity:



This icon is designated to set the polarity of the process in use: DC+, AC stick, DC- & AC TIG operations.

NOTE: Pressing the button assigned to process POLARITY will toggle the illumination of the icon between DC & AC polarity.

Process:



The function of this icon is to allow the user to set the determined process.

1. High-Frequency TIG
2. Lift-Start TIG
3. Stick – Soft Mode (7018 style electrodes)
4. Stick- Crisp Mode (6010 Style electrodes)

NOTE: Arc control parameters, Hot start and arc force parameters, are different in two stick modes. In menu SMAW is possible to change hot start and arc force diagram.

NOTE: Pressing the button assigned to PROCESS selection will toggle the illumination of the icon from left-to-right following the progression of the numbers.

Output:

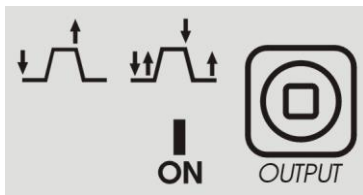

This section is designated to allow the operator to set the desired output control method

1. 2 STEP
2. 4 STEP
3. ON:  no trigger required to start.

Pressing the button assigned to OUTPUT selection will toggle the illumination of the icon from left-to-right

AC Wave Shape:

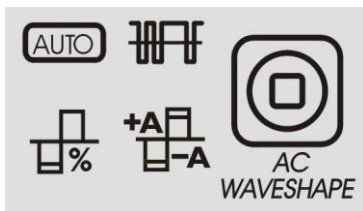

These icons allow the operator to customize the arc-performance for TIG welding in AC polarity only. AUTO and Expert Mode:

By default the AUTO icon is lit. This means that AC waveshape parameters are automatically managed depending on the welding current. The only available parameter is AC-Frequency.

AC-Frequency: This function controls the frequency of the AC Wave shape in cycles per second

To enable Expert mode:

- Push the AC WAVESHAP button twice: The AUTO icon will start to blink and the display will show the message AUTO ON.
- Turn the encoder to select AUTO OFF
- Confirm the selection by pushing the AC WAVESHAP button again. The AUTO icon will turn OFF and all the AC WAVESHAP parameters will become available.

To revert to AUTO mode perform again the steps above pushing several times until AUTO icon will start blinking, then select AUTO ON with the encoder.

In Expert mode the following parameters are available:



1. AC-Frequency: This function controls the frequency of the AC Wave shape in cycles per second.
2. AC-Balance: AC balance controls the amount of time, as a percentage, that the polarity is electrode negative.
3. Electrode Negative/Positive offset: This function controls the amperage setting for the negative and positive side of the wave when TIG welding in AC polarity.

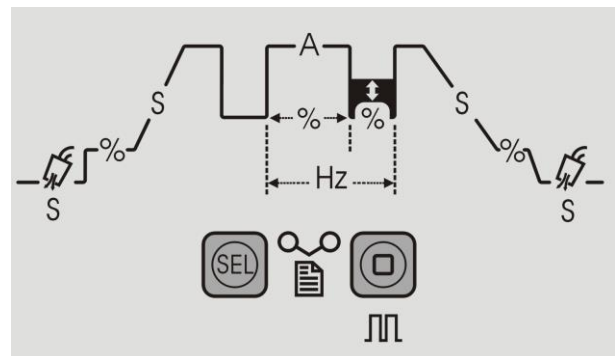

The voltage display screen shows an abbreviated description of the icon selected. The amperage display screen shows the value to be adjusted.

Sequencer Functions:



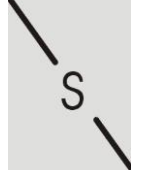

The sequencer allows for the customization of the TIG welding operation both in AC & DC- polarities. Pressing the "Sel" button will cycle through the process graph.

	Pre-Flow: Sets the time in seconds gas will flow prior to arc-start initiation
	Starting Current: Sets the starting amperage for the process.
	Initial Slope: Sets the time in seconds it takes the starting current to reach normal operating amperage.

	Operating Amperage: Sets the amperage for all welding process permitted.
	Final Slope: Sets the time in seconds it takes the operating amperage to ramp down to the Finishing current.
	Finishing Current: Sets the finishing amperage for the process.
	Post Flow: Sets the time in seconds gas will flow after the arc is terminated

Pulse Sequencer Functions:



	Percent Peak Current: This functions sets the amount of time the pulse waveform spends at the peak current setting. This function is set as a percentage of the total time for the pulse cycle.
	Pulses-Per-Second: Sets the total number of pulse cycles per second of time.
	Percent Background Current: Sets the background amperage of the pulse waveform. Background amperage is set as a percentage of the peak current.

Main Amperage Control:



The main amperage control button is intended to be a quick selection method to adjust the main amperage setting. This function will allow users to quickly exit the sequencer portion of the U/I, eliminating the need to cycle through all possible sequencer functions to adjust the main amperage or exit the sequencer menu.

This knob is also a multi-purpose command: see the “Operating Instruction” section for a description of how to use this command for parameter selection.

Displays:

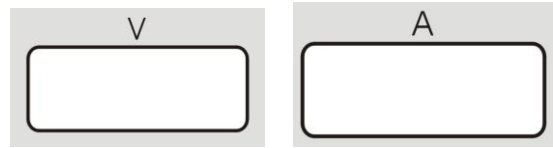

The right meter displays the preset welding current (A) before welding and the actual welding current during welding, and the left meter shown the voltage (V) at the output leads.

A flashing on both displays indicate that the value read is the average value of the previous welding operation. This feature shown the average value for 5seconds after every welding time.

If a remote control is connected (the Remote LED is ON), the left meter (A) indicates the preset and the actual welding current following the instruction explained in the “Remote LED” description above.

The displays are used to indicate during setting of parameters, the name and the value of them. Also are used for menu indication and error codes displaying.

Memory Selection:

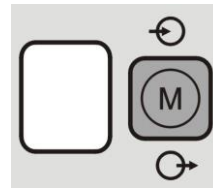

The memory function is designed to allow the operator to save up to 9 specific welding procedures. This memory button will have two functions:

1. Save memory settings
2. Recall memory settings.

Selecting Memory Functions: Pressing the memory button will allow the user to toggle between “saving” a memory, “recalling” a memory or operating without using a memory setting.

1. Pushing 1 time “M” icon, SAVE icon turned on.
2. Pushing 2 times “M” icon, RECALL icon turned on.
3. Pushing 3 times Icon and displays turn off.

Saving Memory Settings:

In order to save process settings into a memory location it is first necessary to press the memory button so that the “memory save” icon is highlighted. Once highlighted, the number on the screen will flash to indicate this number can be changed by turning the control knob below, and the voltage and amperage meters will say “MEM SET”. Once the desired memory location has been selected using the control knob, pressing and holding the memory button for 3 seconds will save the settings in that location. During the 3 second hold period the “memory save” icon will flash. After 3 seconds the displays will show “MEM SAVE”

OPERATION:

- 1.) Press Memory button to highlight "Memory Save" icon;
- 2.) Turn Control Knob to Select memory location;
- 3.) Press and hold memory button for 3 seconds.

Recalling Memory Settings:

In order to recall process settings it is first necessary to press the memory button so that the "memory recall" icon is highlighted. Once highlighted, the number on the screen will flash to indicate this number can be changed by turning the control knob below, and the voltage and amperage meters will say "MEM RECL". Once the desired memory location has been selected using the control knob, pressing and holding the memory button for 3 seconds will recall the settings from that location. During the 3 second hold period the "memory recall" icon will flash. After 3 seconds the displays will show "RECL MEM"





OPERATION:



- 1.) Press Memory button to highlight "Memory Recall" icon.
- 2.) Turn Control Knob to Select memory location.
- 3.) Press and hold memory button for 3 seconds.

Menu:





This unit permits an advance setting divided in 3 menu:

- 1.) Press and Hold  for 5 seconds to access setup menu "GTAW".
- 2.) Press and Hold  for 5 seconds to access setup menu "SMAW".
- 3.) Press and Hold  +  for 5 seconds to access setup menu "SYS".
- 4.) Upon entering one of the three menus , "GTAW", "SMAW", or "SYS", menu progression is

accomplished by pressing  While moving backward is accomplished by pressing 

- 5.) Changes to menu items will be accomplished by

using the Control Knob 

- 6.) After an item is changed it will be saved if  or  is pressed.



- 7.) Each menu can be exited by pressing 

Operating Instruction

DC Stick (SMAW) Welding

To start DC Stick welding process:

- 1.) Set polarity 
- 2.) To select Stick welding:

Process	Visualization
	 Crisp
	 Soft

Press MODE several times until the LED above lights up

 (led ON) is turned on.

When the Stick position is selected, the following welding features are enabled:

- Hot Start: This is a temporary increase in the output current during the start of the stick welding process. This helps ignite the arc quickly and reliably.
- Anti-Sticking: This is a function which decreases the output current of the machine to a low level when the operator makes an error and sticks the electrode to the work piece. This decrease in current allows the operator to remove the electrode from the electrode holder without creating large sparks which can damage the electrode holder.
- Auto Adaptive Arc Force: this function increases temporary the output current, used to clear intermittent connections between the electrode and the weld puddle that occur during stick welding.

This is an active control feature that guarantees the best arrangement between the arc stability and spatter presence. The feature "Auto Adaptive Arc Force" has instead of a fixed or manual regulation, an automatic and multilevel setting; its intensity depends by the output voltage and it is calculated in real time by the microprocessor where are also mapped the Arc Force levels. The control measure in each instant the output voltage and it determines the amount of the peak of current to apply; that value is enough to breaks the metal drop that is being transferred from the electrode to the workpiece as to guarantee the arc stability, but not too high to avoid spatters around the welding puddle. That means:

- Electrode / workpiece sticking prevention, also with low current values.
- Spatters reduction.

The welding operations are simplified and the welded joins looks better, also if not brushed after the welding.

In Stick mode, two different setup are available, and they are completely separate into Process setup:

- SOFT Stick: For a welding with a low spatter presence.
- CRISP Stick (Factory Default): For an aggressive welding, with an increased Arc stability.

For default the polarity is DC+. To change in DC- see menu SMAW operation section.

See menu SMAW to change value of hot start and arc force.

AC Stick Welding

To start AC Stick welding process:

- 3.) Set polarity 
- 4.) To select Stick welding:

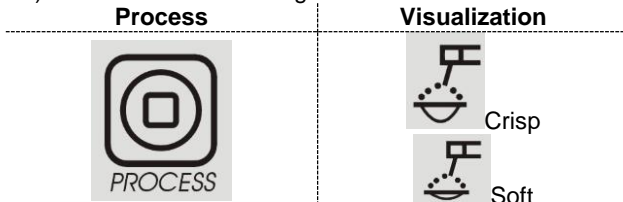

Press MODE several times until the LED above lights up



(led ON) is turned on.

The output current wave form is a 60Hz sinusoidal current with balance 50% without offset. It's not possible to change any parameters of AC Wave.

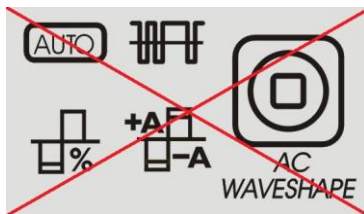

GTAW welding

DC TIG Welding

To start DC TIG welding process:

- 5.) Set polarity 
- 6.) To select TIG welding:

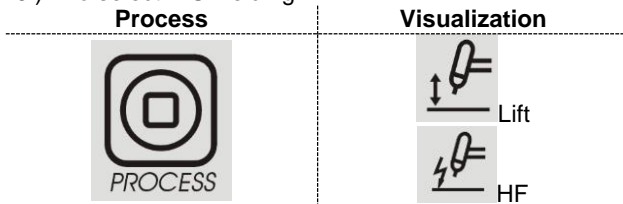

Press MODE several times until the LED above lights up

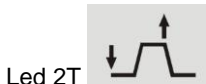

Led 2T  turned on for default.

LIFT TIG

When the mode pushbutton is in the Lift TIG position, the machine is ready for Lift TIG welding. Lift TIG is a method of starting a TIG weld by first pressing the TIG torch electrode on the work piece in order to create a low current short circuit. Then, the electrode is lifted from the work piece to start the TIG arc.

HF TIG

When the mode pushbutton is in HF TIG position, the machine is ready for HF TIG welding. During the HF TIG mode, the TIG arc is started by HF without pressing

the electrode on the work piece. The HF used for starting the TIG arc will remain on for 3 seconds; if the arc is not started in this time limit, the trigger sequence must be restarted.

NOTE: The HF start strength is adjusted to the tungstense and type, which can be selected in menu GTAW.

AC TIG Welding

To start AC TIG welding process:

- 1.) Set polarity 
- 2.) To select AC TIG welding:

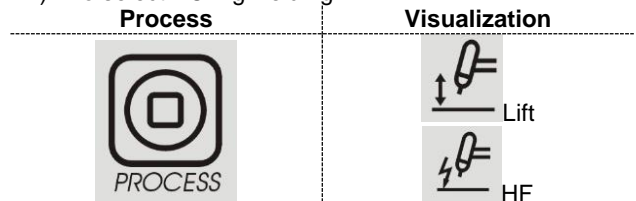

Press MODE several times until the LED above lights up



2T led is turned on for default.

Ac wave shape section is available. About Lift and Tig starting see section above.

Tig Welding Sequences

During no welding operation at each pressure of SEL push button, it's possible to step through all sequencer and set parameters.

During welding the Sel pushbutton is enabled for the following functions:





- Output current
- Only if Pulse Function is active: is possible operates on the values of Duty (%), Frequency (Hz) and Background current (A).

The new parameter value is automatically saved.

TIG Trigger Sequences

TIG welding can be done in either the 2-step or 4-step mode. The specific sequences of operation for the trigger modes are explained below.

Legenda of the symbols used:

	Torch Pushbutton
	Output Current
	Gas Pre-flow
	Gas
	Gas Post-flow

2-Step Trigger Sequence

To select 2-Step sequence:

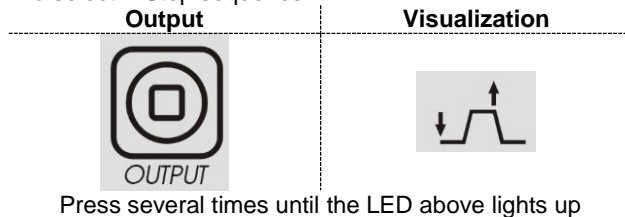

With the 2-step trigger mode and a TIG welding mode selected, the following welding sequence will occur.

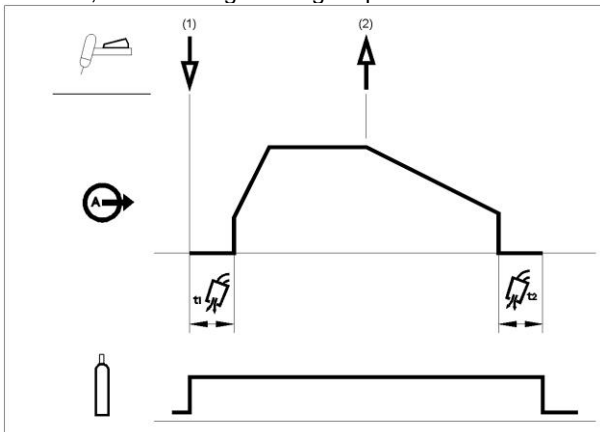

1. Press and hold the TIG torch trigger to start the sequence. The machine will open the gas valve to start the flow of the shielding gas. After the preflow time, to purge air from the torch hose, the output of the machine is turned ON. At this time the arc is started according to the selected welding mode. The initial current is set to 25A for LIFT starting (starting current parameter is disabled in the sequencer) or set according to the Starting current parameter for

HF starting. After the arc is started the output current will be increased at a controlled rate, or upslope time, until the Welding current is reached.

If the torch trigger is released during the upslope time the arc will stop immediately and the output of the machine is turned OFF.

2. Release the TIG torch trigger to stop welding. The machine will now decrease the output current at a controlled rate, or downslope time, until the Crater current is reached and the output of the machine is turned OFF.

After the arc is turned OFF, the gas valve will remain open to continue the flow of the shielding gas to the hot electrode and work piece.

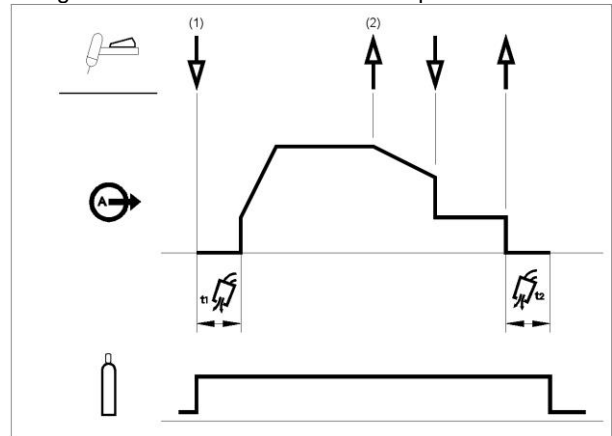

As shown above, it is possible to press and hold the TIG torch trigger a second time during downslope to end the downslope function and maintain the output current at the Crater current. When the TIG torch trigger is released the output will turn OFF and the postflow time will start. This operation sequence, 2-step with restart disabled, is the default setting from the factory.

2-Step Trigger Sequence with Restart Option

To select 2-Step with restart sequence:

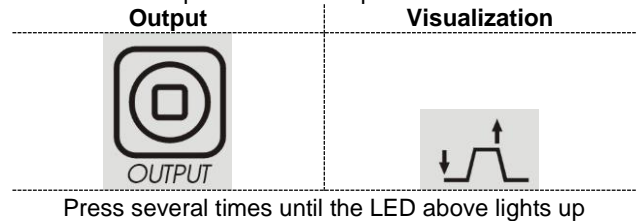

Enter Menu GTAW and enable 2RST option.

If the 2-step restart option is enabled from the setup menu the following sequence will occur:

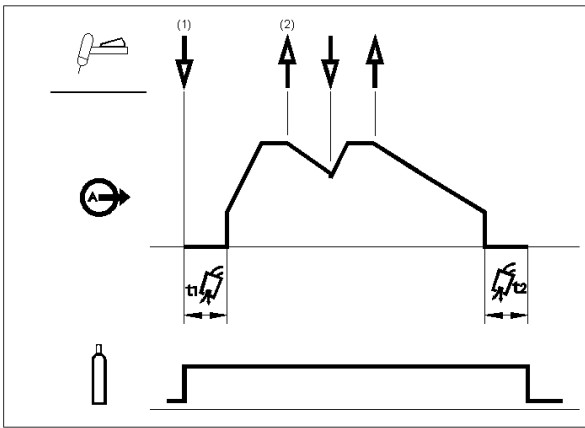

1. Press and hold the TIG torch trigger to start the sequence as described above.
2. Release the TIG torch trigger to start the downslope. During this time press and hold the TIG torch trigger to restart welding. The output current will increase again at a controlled rate until the Welding current is reached. This sequence can be repeated as many times as necessary. When the welding is complete release the TIG torch trigger. When the Crater current is reached the output of the machine is turned OFF.

4-Step Trigger Sequence

To select 4-Step sequence:

Output



Press several times until the LED above lights up

Visualization

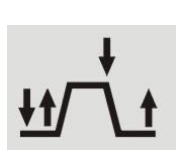

With the 4-step trigger mode and a TIG welding mode selected, the following welding sequence will occur.

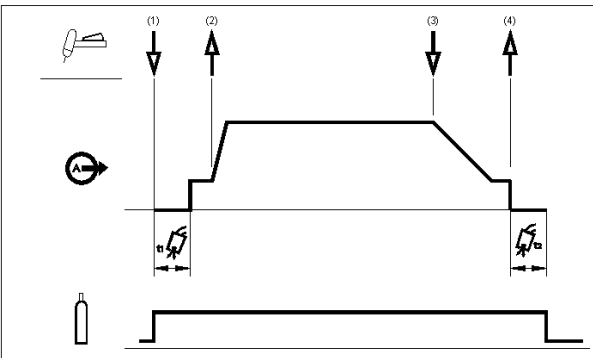

1. Press and hold the TIG torch trigger to start the sequence. The machine will open the gas valve to start the flow of the shielding gas. After the preflow time, to purge air from the torch hose, the output of the machine is turned ON. At this time the arc is started according to the selected welding mode. In LIFT starting the touching current is 25A until the short circuit is removed. After the arc is started the output current will be at the Start current. This condition can be maintained as long as necessary.

If the Start current is not necessary, do not hold the TIG torch trigger as described at the beginning of this step. In this condition, the machine will pass

from Step 1 to Step 2 when the arc is started.

2. Releasing the TIG torch trigger starts the upslope function. The output current will be increased at a controlled rate, or upslope time, until the Welding current is reached. If the torch trigger is pushed during the upslope time the arc will stop immediately and the output of the machine is turned OFF.
3. Press and hold the TIG torch trigger when the main part of the weld is complete. The machine will now decrease the output current at a controlled rate, or downslope time, until the Crater current is reached.
4. This Crater current can be maintained as long as necessary. When the TIG torch trigger is released the output of the machine is turned OFF and the postflow time will start.

As shown here, after the TIG torch trigger is quickly pressed and released from step 3A, it is possible to press and hold the TIG torch trigger another time to end the downslope time and maintain the output current at the Crater current. When the TIG torch trigger is released the output will turn OFF.

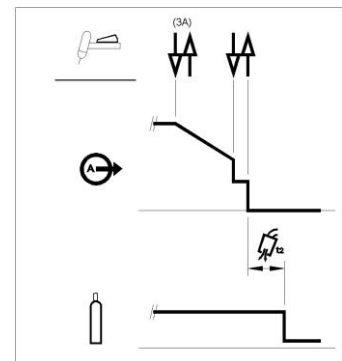

This sequence operation, 4-step with restart disabled, is the default setting from the factory.

4-Step Trigger Sequence with Restart Option

To select 4-Step with restart sequence:

Output



Press several times until the LED above lights up

Visualization

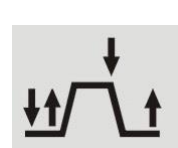

Enter Menu GTAW and enable 4RST option.

If 4-step restart is enabled from the setup menu the following sequence will occur for steps 3 and 4 (steps 1 and 2 are not altered by the restart option):

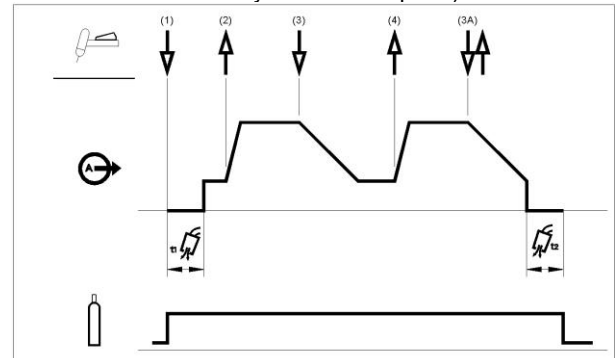

3. Press and hold the TIG torch trigger. The machine will now decrease the output current at a controlled rate, or downslope time, until the Crater current is reached.

4. Release the TIG torch trigger. The output current will again increase to the Welding current, like in step 2, to continue welding.

If the weld is completely finished, use the following sequence instead of step 3 described above.

3A. Quickly press and release the TIG torch trigger. The machine will now decrease the output current at a controlled rate, or downslope time, until the Crater current is reached and the output of the machine is turned OFF. After the arc is turned OFF the postflow time will start.

As shown here, after the TIG torch trigger is quickly pressed and released from step 3A, it is possible to press and hold the TIG torch trigger another time to end the downslope time and maintain the output current at the Crater current. When the TIG torch trigger is released the output will again increase to the Welding current, like in step 4, to continue welding. When the main part of the weld is complete go to step 3.

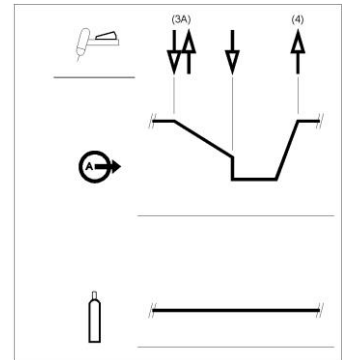

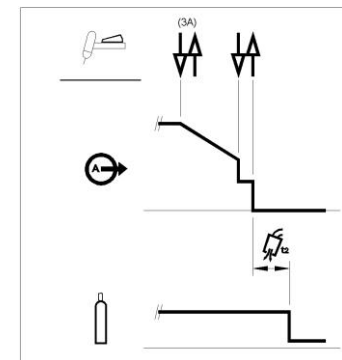

As shown here, again after the TIG torch trigger is quickly pressed and released from step 3A, it is possible to quickly press and release the TIG torch trigger a second time to end the downslope time and stop welding.



Spot TIG (GTAW welding)

Enter in Menu GTAW to enable spot welding function. When enabled, the spot tig function replaces the 2S trigger sequence.

To select Spot function:

Output	Visualization
	
Press until the LED above lights up	

This welding mode is especially thought to tack or weld thin materials.

It uses HF start and immediately It delivers the set current without any upslope/downslope.

When spot is selected automatically you have this setting:

- 2S without restart
- Working only in HF mode
- Upslope and downslope are disabled

When spot is selected in left display without any welding operation you can see the text:

S-0.0

While right displays shown the set current.

For default the spot time is 0s: that means the output current is delivered only when the trigger button is pushed.

The welding time is set with the spot time control and will be constant independently from the operation of the Trigger.

To set the spot time, user has to push SEL button until text SPT appears on the left display: turning now the main know is possible to set SPT time from 0 to 100s

Bi-Level (Set/A2) Trigger sequence

Enter Menu GTAW and enable BILV option.

When enabled, the bilevel tig function replaces the 4S trigger sequence.

To select Bi-Level sequence:

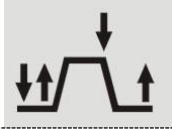
Output	Visualization
	

Press several times until the LED above lights up

When bilevel is selected in left display without any welding operation you can see the text:

B-0.0

With this sequence the arc is started as in the 4S sequence, this means that steps 1 and 2 are the same.

3. Quickly press and release the TIG torch trigger. The machine will switch the current level from Set to A2 (background current). Each time this trigger action is repeated the current level will switch between the two levels.
 - 3A. Press and hold the TIG torch trigger when the main part of the weld is complete. The machine will now decrease the output current at a controlled rate, or downslope time, until the Crater current is reached. This Crater current can be maintained as long as necessary.



To set the A2 level, user has to push SEL button until text A2 appears on the left display: turning now the main knob is possible to set A2 in percentage of the setting current.

NOTE: The Restart option and the Pulse function are not available for Bi-Level Trigger sequence

LIFT TIG ON sequence

When lift tig process is selected, it is possible to performe welding operation without the use of a trigger.



To select ON sequence:

Output	Visualization
	

Press several times until the LED above lights up

When the sequence is selected it is possible to start a weld with the lift method without pushing trigger. To end the weld it is necessary to break the arc. The parameter Starting current, Final slope and finishing current are ignored.

List of parameters and Factory stored programs

Function	Factory Configuration Default	Selectable Value Range 	Displayed parameter name	Displayed value
			V	A
Preflow	.5	0 - 25s (step 0.1s)	PRE	Current selected value (s)
Starting Current	100	10 – 200 % (step 1%)	STRT	Current selected value (%)
Initial slope	0.1	0 – 5s (step 0.1s)	UP	Current selected value (s)
Operating Amperage	50	2 – 300 A (step 1A) (TIG)		Current selected value (A)
		5 – 270 A (step 1A) (Stick)		
Final Slope	0	0 - 25s (step 0.1s)	DOWN	Current selected value (s)
Finishing Current	30	10 – 90 % (step 1%)	END	Current selected value (%)
Post flow	AUTO	0,1 - 60s (step 0.1s) Note A	POST	Current selected value (s)
Percent of Peak Current / Duty Cycle (Only when pulse function is enabled)	40	5-95 (step 5%) Note B	PEAK	% of FREQ
Pulses-Per-Second DC (Only when pulse function is enabled)	0.1	0,1 – 10 Hz (step 0.1Hz) 10 – 500Hz (step 1Hz) 500 – 2000Hz (step 10Hz)	FREQ	Current selected value (Hz)
Pulses-Per-Second AC (Only when pulse function is enabled)	0.1	0,1 – 10 Hz (step 0.1Hz) 10 – 100Hz (step 1Hz) Note C	FREQ	Current selected value (Hz)
Background Current (Only when pulse function is enabled)	25	10 -90 % (step 1%)	BACK	Current selected value (%)
SPOT time (Only when spot function is enabled)	0	0 – 10s (step 0.1s) 0 – 100s (step 0.1s)	SPT	Current selected value (s)
Low level background (Only when Bilevel function is enabled)	25	10 -90 % (step 1%)	A2	Current selected value (%)
AC Wave Balance				
Function	Factory Configuration Default	Selectable Value Range 	Displayed parameter name	Displayed value
			V	A
EN Offset	AUTO	2 – 300A (step 1A)	EN	Current selected value (A)
EP Offset	AUTO	2 – 300A (step 1A)	EP	Current selected value (A)
AC-Balance	AUTO	35 – 95 % (step 1%)	%BAL	Current selected value (%)
AC-Frequency	120	40 – 400Hz (step 1Hz)	FREQ	Current selected value (Hz)

Note A: When AUTO is selected means 1s/10A; minimum value is 3s.

Note B: for frequency value higher than 500Hz, PEAK is locked to 50%.

Note C: In AC polarity the pulse frequency is limited to ¼ of the AC-frequency: if AC frequency is 120Hz that means the max pulse frequency is 30Hz. If the pulse frequency is higher than 1/10 of the AC frequency, the PEAK is fixed to 50%.

Advanced menu Menu GTAW

To enter into Menu GTAW see section Menu, described above

Menu GTAW

Function	Factory Configuration Default	Selectable Value Range 	Displayed parameter name	Displayed value
			V	A
Wave Form	SQRE	SOFT SINE SQRE TRI	WAVE	Current selected value type
Tungstene size	AUTO	AUTO (Note D) 0.5mm (0.02") 1mm (0.04") 1.6mm (1/16") 2.4mm (3/32") 3.2mm (1/8") 4mm (5/32") ADV (Note E)	DIA	Current selected value
Tungsten Type (Note F)*	GRN	GRN WHITE GREY TURQ GOLD	TYPE	Current selected value Colour
Restart 2S	OFF	ON/OFF	2RST	Current selected value (-)
Restart 4S	OFF	ON/OFF	4RST	Current selected value (-)
Bilevel function	OFF	ON/OFF	BILV	Current selected value (-)
Spot function	OFF	ON/OFF	SPOT	Current selected value (s)

TIG STARTING PARAMETERS				
Function	Factory Configuration Default	Selectable Value Range 	Displayed parameter name	Displayed value
			V	A
Polarity	EP	EN/EP	POL	Current selected value (-)
Amperage	120	2 – 200A (step 1A)	SCRT	Current selected value (A)
Time	100	1 – 1000ms (step 1ms)	STME	Current selected value (ms)
Start Slope Time	40	0 – 1000ms (step 1ms)	SSLP	Current selected value (ms)
Preset Amperage Min	5	2-50A (step 1A)	PCRT	Current selected value (A)

Note D. When AUTO is selected, the starting parameters are automatically recalled based on the set current adjustable by main knob in the front panel. Diameter of the electrode is automatically recalled based on the following table

User dialed weld I (AMP)	Tungsten diameter
> 227	3.2 mm
<=227 and > 153	2.4 mm
<=153 and > 67	1.6 mm
<=67 and > 27	1 mm
<=27	0.5 mm

4mm diameter starting parameters are never recalled when DIA = AUTO.

Note E. When ADV option is enabled, the user can create his personal starting setting according to "TIG AC starting parameters below).

Note F. This option is accessible only when a specific diameter is selected. When DIA = AUTO or DIA = ADV, that option is not visible.

WAVE-FORM selection

With this option is possible to select between four different waveforms

- "Soft" shape: to have a nice balance between a focused Arc and low noise.
- "Fast" shape: to have more focused arc.
- "Sin" Wave shape: comparable with older conventional machines, not very concentrated but very soft.
- "Triangle" shape: to reduce the amount of heat delivered to the workpiece.

Default setting: SQRE

Tungsten Size and Type

In order to ensure the maximum performance and arc striking reliability the operating parameters of the machine are automatically adjusted to the type and size of the tungsten electrode in use. Selecting the appropriate diameter of the electrode, automatically a recorder set of parameter is recalled to assure in both DC and AC mode a good arc striking. For AC welding advanced users is present the possibility to modify the AC starting parameters

Tig AC starting parameters

The unit is delivered not allowing to the user to change starting parameters: for default option "Tig starting parameters", from now on TSTR, is selected in AUTO. When AUTO is selected for TSTR option, the value of the 4 parameters settable (SCRT, STME, SSLP and PCRT) and polarity (EP) are stored in unit and can be modified by the user .

Following picture show the meaning of the parameter for a local hand working. The ramp in SSLP time ends when STRT current level is reached: if STRT is lower than PCRT, the level will be PCRT.

Note: when PCRT is set in the range above, the minimum current delivered by the unit is PCRT level

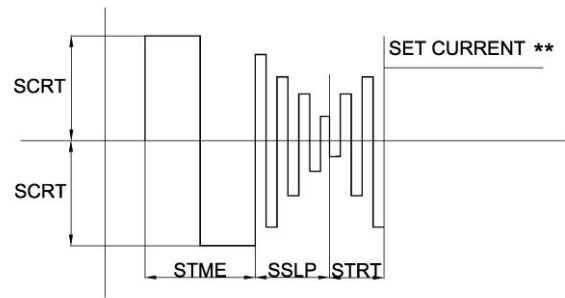

The starting sequence changes also if the foot paddle is present: in fact taking care of the STRT level is not settable, the level at the end of the SSLP ramp is the level from the footpaddle or the PCRT level.

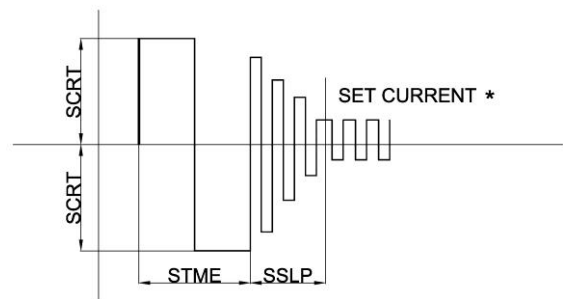

NOTE: the setting parameters stored assure the striking of the arc when correct electrode (diameter and colour) has been correctly selected.

In order to allow maximum flexibility to advanced users that need complete control over the welding process, the AC starting parameters can be modified by selecting MANL for the TSTR (Tig Starting Parameters) option in Menu C.

User can change polarity,

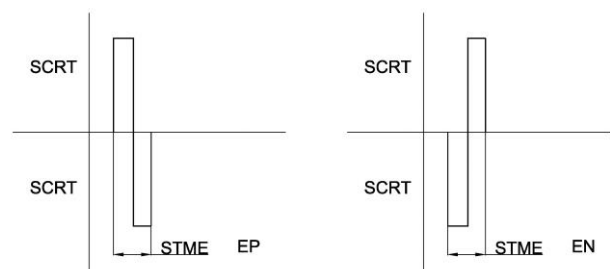

values of the other parameters creating its personal waveform for starting.

NOTE: the changing of the parameters above, could affect the striking of the arc if not correcting set.

Restart 2S, Restart 4S, Spot and Bilevel

See GTAW section above for details about mode of working.

Menu SMAW

To enter into Menu SMAW see section Menu, described above

Menu SMAW

Function	Factory Configuration Default	Selectable Value Range 	Displayed parameter name	Displayed value
			V	A
Arc Force	SOFT: 35%	0 – 75% (step 1%)	FRCE	Current selected value (%)
	CRISP: 75%	75 – 200% (step 1%)		
Hot Start	SOFT: 30%	0 – 75% (step 1%)	HSTR	Current selected value (%)
	CRISP: 50%	50 – 200% (step 1%)		
Stick Polarity	DC+	DC+ or DC-	STPL	Current selected value (-)

ARC FORCE and HOT START

With those two parameters, user can change the behaviour of unit in STICK DC stick welding. See DC stick welding for a better understanding of both features. Setting is ignored for AC STICK or GTAW mode of workin.

STICK POLARITY

With this function is possible to change polarity of the electrode clamp without any change in work cables connections. For default stick polairity is DC+.

Menu SYS

To enter into Menu SYS see section Menu, described above

Menu SYS

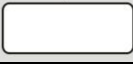
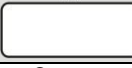
Function	Factory Configuration Default	Selectable Value Range 	Displayed parameter name V 	Displayed value A 
Units	mm	mm / INCH	UNIT	Current selected value (s)
VRD	OFF	ON/OFF	VRD	
LED Brightness/Intensity	X	LOW	LED	
		MED		
		HIGH		
TIG Remote Options	AMP	FOOT	RMTE	Current selected value type
		AMP		
Up/Down*	OFF	OFF	UPDN	Current selected value type
		AMP		
		MEM		
MAX amperage*	OFF	51- 300 – OFF	AMPS	Current selected value (A)
Cooler option	AUTO	AUTO	COOL	Current selected value type
		ON		
Control firmware revision	N/A	N/A	CTRL	Current SW revision
UI firmware revision	N/A	N/A	UI	Current SW revision
Diagnostics	N/A	List of #'s	ERR	
Arc Time	-	105 hours	HOUR	Current selected value (hour)
Arc Counter	-	55 welds	CNT	Current selected value (welds)
Reset	N/A	YES/NO	RSET	

*Only available for CODE 50595

LED Brightness/Intensity

By this option is possible to select the intensity of the LEDs present in the user interface: three level can be selected by the user. High level is recommended when the unit is used outside with high sun light luminosity

Tig Remote options

This remote section in Menu SYS is dedicate to select the appropriate kind of remote devices connected. Unit detects itself the present of a remote devices (amptrol, footpaddle): selecting AMP you indicate the unit and amptrol is connected while selecting FOOT a footpaddle is conected. By default this selection is for AMP. The selection of FOOT and AMP changes dynamically also the possibility to select and change parameters as described in previous paragraphs.

COOLER option

This option permits to the user to activate permanently the water cooler when ON is selected. Cooler is switched OFF only in Idle state.

For default AUTO is enable and the water cooler follows the timeline of welding, green mode and idle state. Cooler is switched OFF when green mode is activated; the entering in IDLE mode confirms the OFF status of Cooler.

UP/DOWN options (only for CODE 12595)

AMP MODE

Three operating modes, corresponding to different states of the machine, are identified:

- 1) Before welding: pressing the UP or DOWN key causes a change of value of the Set current.
- 2) While welding: pressing the UP or DOWN key causes a change of value of the Set current during all phases of welding process except during the start functions, where the UP/DOWN function is masked.
- 3) Pre/post Flow: pressing the UP or DOWN key causes a change of value of the Set current.

The change will be realized in two ways depending on pressed button time:

- 1) Step function: pressing the UP/DOWN button for a minimum time of 200ms and releasing it, causes the set current raises/falls of 1A.
- 2) Ramp function Pressing the UP/DOWN button for a time greater than 1 sec., the set current start to increase/decrease with a (5A/s) ramp. If press for more than 5 sec increase/decrease with a ramp of (10A/s). The current ramp will end when the UP/DOWN button previously pressed is released.
- 3) When a remote (FOOT or AMP) device is present, depending on welding process selected, the UP/DOWN behavior is different.

In SMAW welding mode, the remote device set the amperage setting in the whole range, bypassing the main control knob in front User interface. In that case the signals coming from UP/DOWN **are ignored**.

In GTAW mode of welding, the remote device set the percentage of the main set delivered by the machine. Regulating the main amperage, the UP/DOWN with remote device will work as described above.

MEM MODE

By pressing torch buttons user will be allowed to change over settings stored in memory locations from 1 to 9. The feature is not available during welding.

MAX amperage option

This option allows the user to set the maximum current supplied by machine.

Error Codes and troubleshooting.

If an error occurs, turn Off the machine, wait for a few seconds, then turn ON again. If the error remains, a maintenance is required. Please contact the nearest technical service center or Lincoln Electric and report the error code displayed on the meter of the Front Panel.

Err	Error code table
01	<p>Input voltage too low</p> <p>● LED is blinking.</p> <p>Indicates that an Input Undervoltage protection is active; the Machine restarts automatically when the Input Voltage returns in the correct range.</p>
02	<p>Input voltage too high</p> <p>● LED is blinking.</p> <p>Indicates that an Input Voltage Overvoltage protection is active; the Machine restarts automatically when the Input Voltage returns in the correct range.</p>
03	<p>Wrong input connection</p> <p>● LED blinking.</p> <p>Indicates that the machine is incorrectly wired or connected to a single phase mains supply. To restore the machine:</p> <ul style="list-style-type: none"> • Turn OFF the machine and check the input connection.
06	<p>Inverter voltage lock out</p> <p>● LED blinking.</p> <p>Indicates that an Internal Auxiliary Voltage fault condition is detected.</p> <p>To restore the machine:</p> <ul style="list-style-type: none"> • Turn OFF then ON the Mains Switch to restart the machine.
09	<p>Connection error</p> <p>This error message indicates the communication between Control and UI is not working.</p>
11	<p>Water cooler fault</p> <p>Cooler fluid is not correctly flowing through the torch. See the water cooler instruction manual for more details.</p>
12	<p>AC Switch Overload</p> <p>Indicates that an overload condition occurred. To restore the machine:</p> <ul style="list-style-type: none"> • Turn OFF then ON the Mains Switch to restart the machine.

Arc Time & Arc Counter

These two options show to the welder the total working hours and the total number of arc striking. To reset one or both registers, perform the following procedure:

- Select the option to reset;
- Push SEL button  for 5s. After that time the counter is reset: 0.0 presents in Voltage displays
- Release SEL Button

UI & CTRL firmware revision

By this option it is possible to see the current software revision in both UI and control board.

RESET

By this option an end user can reset all the settings present in the machine to factory default indicated in this manual for all parameters. Memory locations are not affected by this reset.

Electromagnetic Compatibility (EMC)

01/11

This machine has been designed in accordance with all relevant directives and standards. However, it may still generate electromagnetic disturbances that can affect other systems like telecommunications (telephone, radio, and television) or other safety systems. These disturbances can cause safety problems in the affected systems. Read and understand this section to eliminate or reduce the amount of electromagnetic disturbance generated by this machine.



This machine has been designed to operate in an industrial area. The operator must install and operate this equipment as described in this manual. If any electromagnetic disturbances are detected the operator must put in place corrective actions to eliminate these disturbances with, if necessary, assistance from Lincoln Electric. The Class A equipment is not intended for use in residential locations where the electrical power is provided by the public low-voltage supply system. There may be potential difficulties in ensuring electromagnetic compatibility in those locations, due to conducted as well as radiated disturbances. This equipment complies with IEC 61000-3-12 provided that the short-circuit power S_{sc} is greater than or equal to 2227kVA at the interface point between the user's supply and the public system. It is the responsibility of the installer or user of the equipment to ensure, by consultation with the distribution network operator if necessary, that the equipment is connected only to a supply with a short circuit power S_{sc} greater than or equal to 2227kVA.

Before installing the machine, the operator must check the work area for any devices that may malfunction because of electromagnetic disturbances. Consider the following.

- Input and output cables, control cables, and telephone cables that are in or adjacent to the work area and the machine.
- Radio and/or television transmitters and receivers. Computers or computer controlled equipment.
- Safety and control equipment for industrial processes. Equipment for calibration and measurement.
- Personal medical devices like pacemakers and hearing aids.
- Check the electromagnetic immunity for equipment operating in or near the work area. The operator must be sure that all equipment in the area is compatible. This may require additional protection measures.
- The dimensions of the work area to consider will depend on the construction of the area and other activities that are taking place.

Consider the following guidelines to reduce electromagnetic emissions from the machine.

- Connect the machine to the input supply according to this manual. If disturbances occur it may be necessary to take additional precautions such as filtering the input supply.
- The output cables should be kept as short as possible and should be positioned together. If possible connect the work piece to ground in order to reduce the electromagnetic emissions. The operator must check that connecting the work piece to ground does not cause problems or unsafe operating conditions for personnel and equipment.
- Shielding of cables in the work area can reduce electromagnetic emissions. This may be necessary for special applications.

MAINTENANCE

WARNING



ELECTRIC SHOCK can kill

Have an electrician install and service this equipment
Turn the input power off at the fuse box before working on equipment

Do not touch electrically hot parts

Prior to performing preventive maintenance, perform the following capacitor discharge procedure to avoid electric shock.

INPUT DC BUS CAPACITORS DISCHARGE PROCEDURE

1. Remove input power to the ASPECT™300
2. Remove the cover following the instruction available in this Service manual.
3. Check the voltage across the two terminals. Voltage should be zero. If any voltage remains, apply the following procedure.
4. Obtain a high resistance and high wattage resistor (25-1000 ohms and 25 watts minimum). This resistor is NOT supplied with the machine. NEVER USE A SHORTING STRAP FOR THIS PROCEDURE.
5. Locate the two terminals **DC+** and **DC -** on the Caps Board (See Figure 1).
6. Use electrically insulate gloves and insulated pliers. Hold the body of the resistor and connect the resistor leads across the two terminals. Hold the resistor in place for 10 seconds. DO NOT TOUCH CAPACITOR TERMINALS WITH YOUR BARE HANDS.



Figure 1 – W05X1470 Caps Board

ROUTINE MAINTENANCE

1. Keep the welding area around the machine clean and free of combustible materials. No debris should be allowed to collect which could obstruct air flow to the machine
2. Every 6 months the machine should be cleaned with a low pressure and dry airstream. Keeping the machine clean will result in cooler operation and higher reliability.
3. Examine the sheet metal case for dents or breakage. Repair the case as required. Keep the case in good condition to insure that high voltage parts are protected and correct spacing are maintained. All external sheet metal screw must be in place to ensure case strength and electrical ground continuity.

THERMAL PROTECTION

Thermal detection device protect the machine from excessive operating temperatures. Excessive temperatures may be caused by a lack of cooling air or operating the machine beyond the duty cycle and output rating. If excessive operating temperatures should occur, the yellow LED will light and the detection device will prevent output voltage or current.

These detection device are self-resetting once the machine cools sufficiently. If the thermostat shutdown was caused by excessive output or duty cycle and the fan is operating normally, the power switch may be left on and the reset should occur within a 15 minute period. If the fan is not turning or the air intake louvers were obstructed , then the power must be switched off and the fan problem or air obstruction must be corrected.

MAJOR COMPONENTS LOCATION

ASPECT™ 300

1. Mains switch
2. Gas solenoid valve
3. Fan and Fan1
4. Right side: Buck/Boost Board, Caps Board and Inverter Board
5. Output Board
6. Output Diode Board
7. IGBT Board
8. HF Board
9. Input control Board
10. Input Power Board
11. UI and Control Board
12. EMC Filter Board

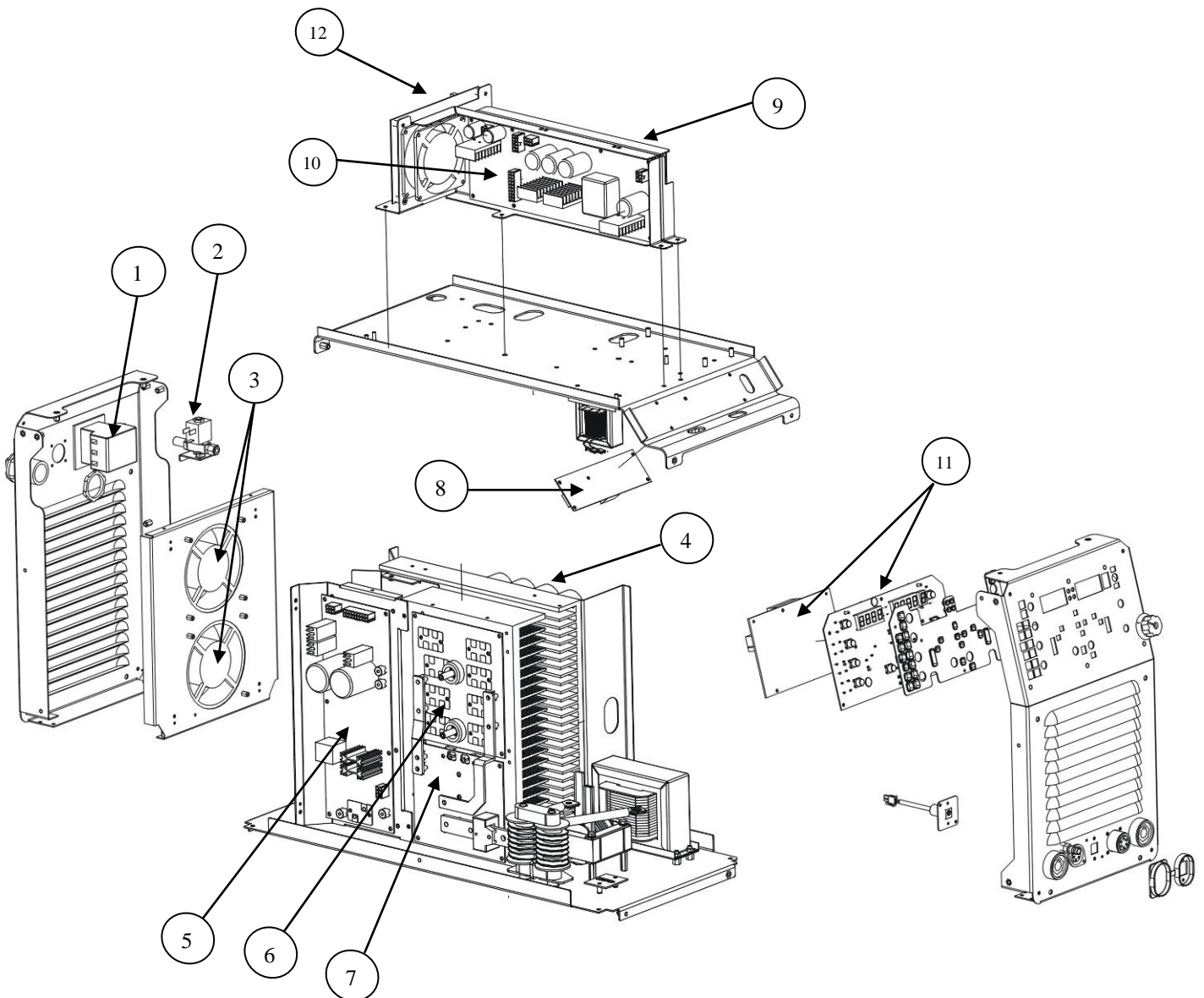

THEORY OF OPERATION

ASPECT™ 300 - SCHEMATIC DIAGRAM

code 52125

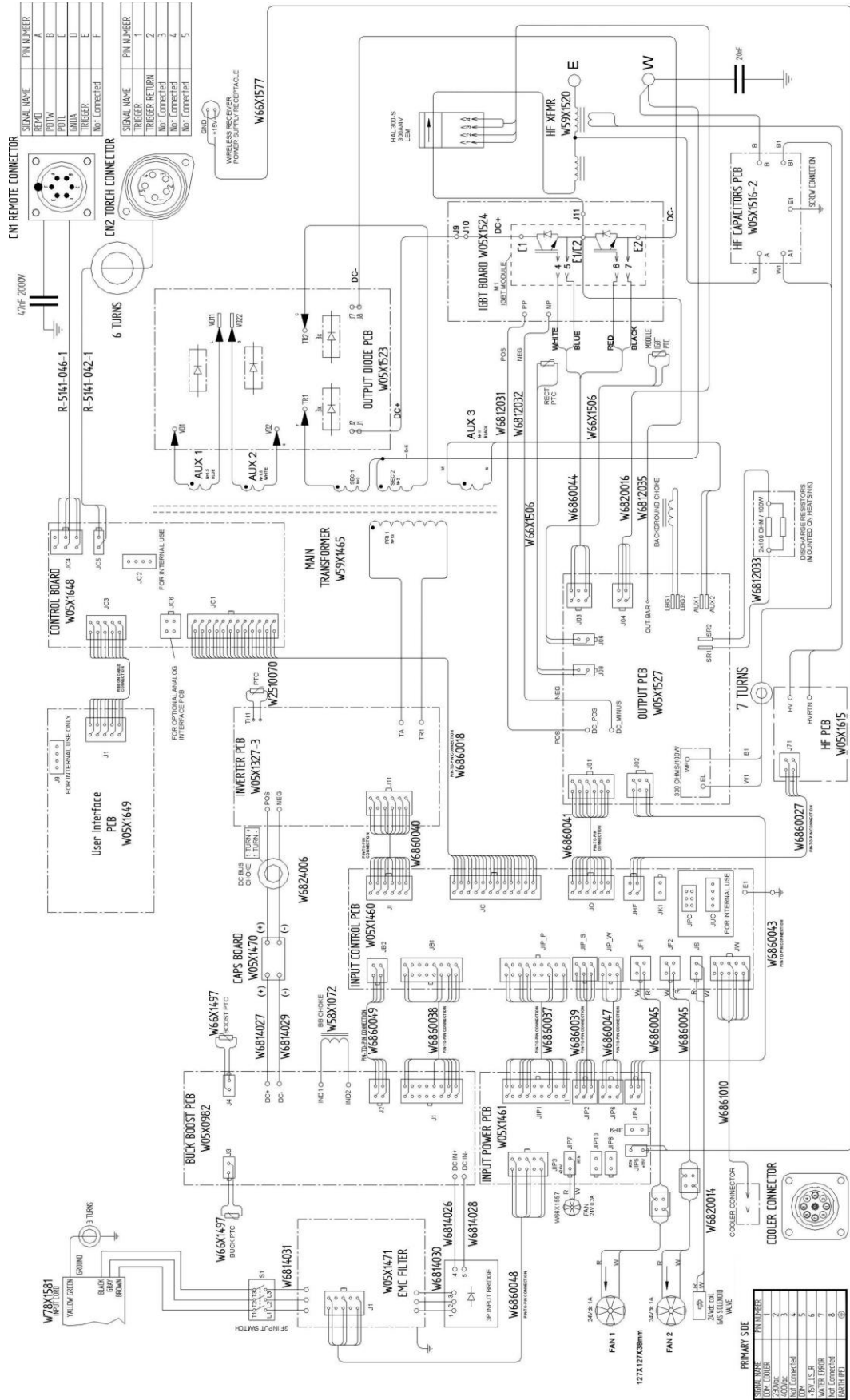

INPUT

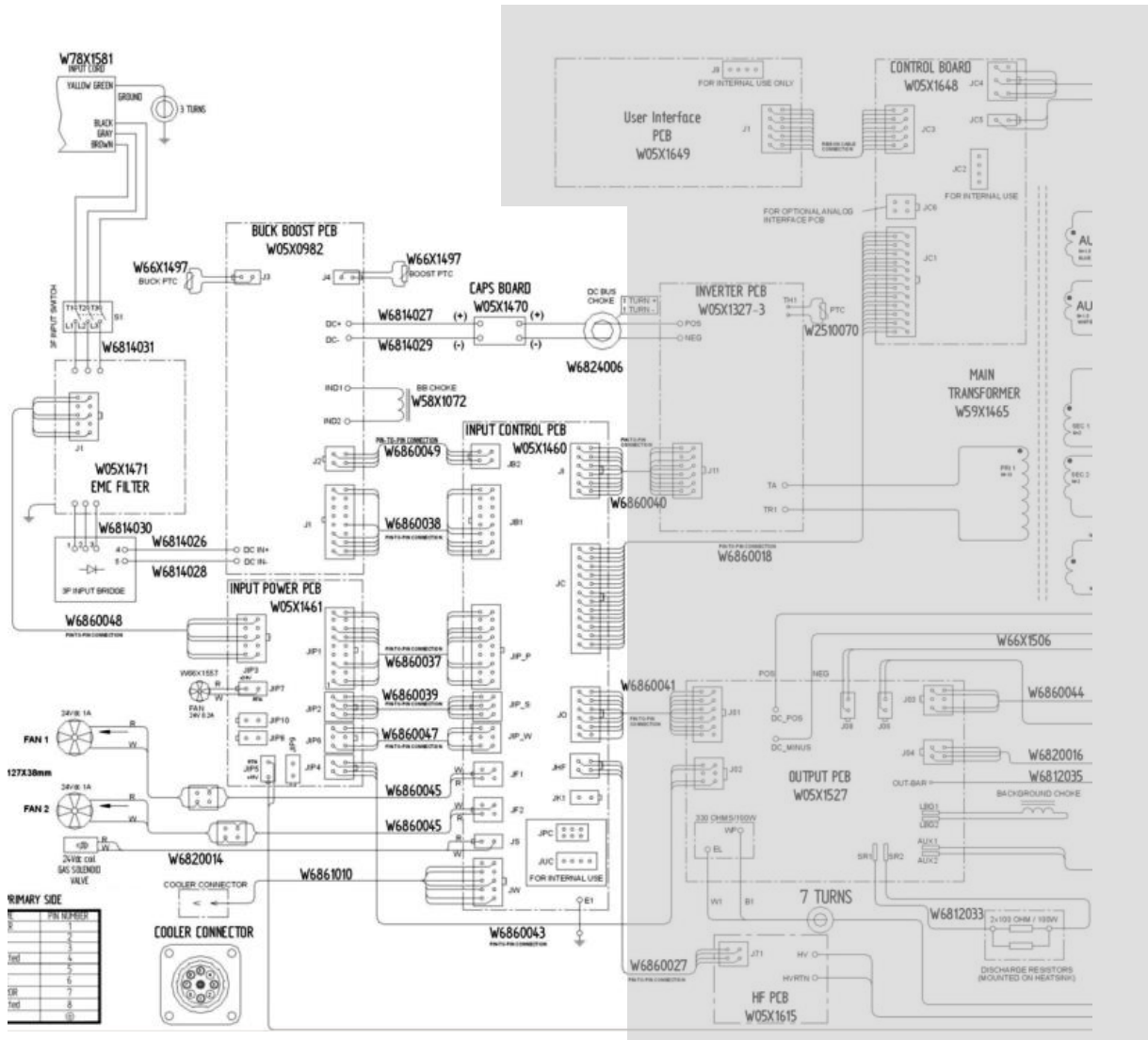

GENERAL DESCRIPTION

The **ASPECT™300** is an inverter based welding power source that offers multi-mode (TIG DC, TIG AC STICK DC and STICK AC) constant current welding. The machine can be operated on three phases input voltage 230Vac or 400Vac 50 or 60 Hz thanks to the Buck/Boost circuitry available on this welding power source. The welding response of these Invertec has been optimized for the stick (SMAW) and TIG (GTAW) welding processes.

EMC FILTER

EMC filter circuit, prevents noise from the machine from being transmitted along the main power line and vice versa, necessary to be in accordance with all relevant directives and standards. EMC filter is also providing the AC power supply to the Input Power Board.

INPUT BRIDGE, INPUT POWER BOARD, BUCK BOOST BOARD, INPUT CONTROL PCB

When the main switch is closed the 230 Vac or 400Vac input power is applied to the input rectifier through the EMC filter where it is rectified to a DC voltage. This rectified input voltage (260 – 565VDC dependent on input voltage) is applied to the

Buck/Boost Power Board. The Buck/Boost Power Board houses a soft-start circuit consisting of a 100 ohm resistor and a DC relay. Initially the DC relay is not activated and the incoming DC voltage is applied to the DC bus capacitors via the 100 ohm resistor. The resistor functions as a current limiting device allowing the DC bus capacitors to charge slowly. The boost switch is active when the input voltage is at 230VAC input. Under this condition the Buck switch is held on the entire time. The Buck switch is active when the input voltage is at 400VAC. Under this condition the Boost switch is not active for most of the time. The Buck/Boost circuit operates at 20kHz. The Buck/Boost circuit's output is a 400 Volt regulated bus that is applied to the Caps Board and to the Inverter Board. Two PTC thermal sensors are present on Buck/Boost heatsink and they are managed by the input control board.

Input Power board is responsible to provide the auxiliary supplies for the machine circuits. The Input Control boards houses the Buck/Boost PWM and driver circuits; it is also driving the machine power-up sequence (pre-charge), fan, HF, gas solenoid and Cooler ON/OFF. It also responsible for all PTC thermal sensors managements and for the rectification of the output current feedback used also by the inverter board output current control circuit.

INVERTER-OUTPUT TRANSFORMER AND OUTPUT DIODE PCB

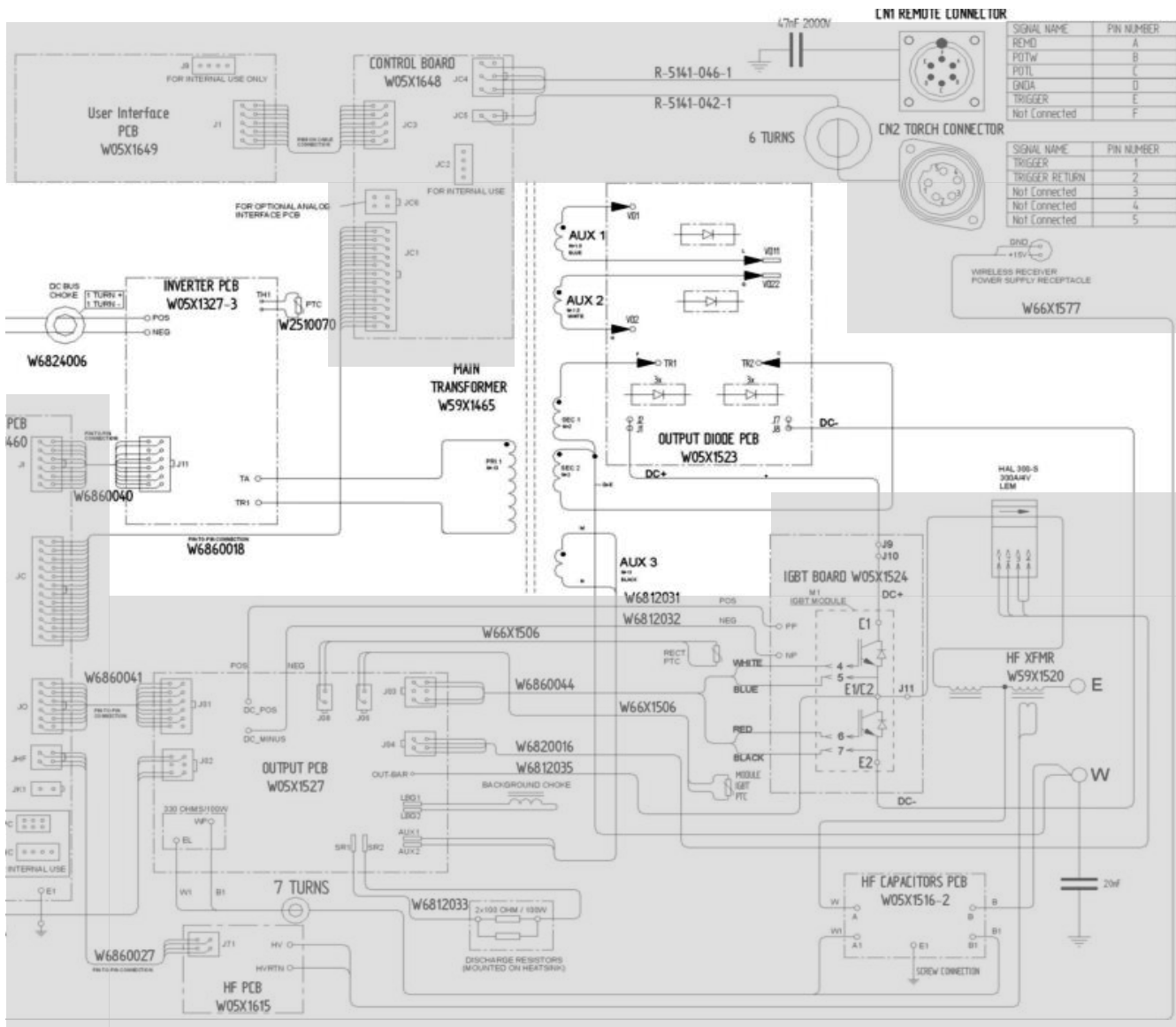

INVERTER, OUTPUT TRANSFORMER AND OUTPUT DIODE PCB

The 400VDC created by the Buck/Boost Board and filtered by the DC bus capacitors is applied to an IGBT controlled full wave bridge inverter that is located on the Inverter Board.

The IGBT switch the DC power from the bus capacitors "on and off," thus supplying pulsed DC current to the main transformer primary windings.

The full bridge inverter switching frequency is 35KHz. Current transformer located on the inverter board monitor the primary current. If the primary current become abnormally high, the inverter control circuit will shut off the IGBTs, thus disabling the machine's output. A PTC thermal protector is also present, to the inverter heatsink, to protect the IGBTs from overheating conditions.

The main transformer insulate the primary circuit from the secondary circuit and reduces the high voltage (low current) input applied to the primary winding and through transformer action develops a lower secondary voltage capable of high output currents. Main transformer has also 2 auxiliary windings for the doubler circuits, that provide the extra voltage required when special stick electrodes, like cellulosic, are used with the machine or during HF TIG arc starting and 1 auxiliary winding for the output PCB snubber capacitor precharge.

The AC output of the Main Transformer is applied to the Output Diode PCB for full rectification depending on the output polarity selected.

OUTPUT BOARD, IGBT BOARD AND HF BOARD

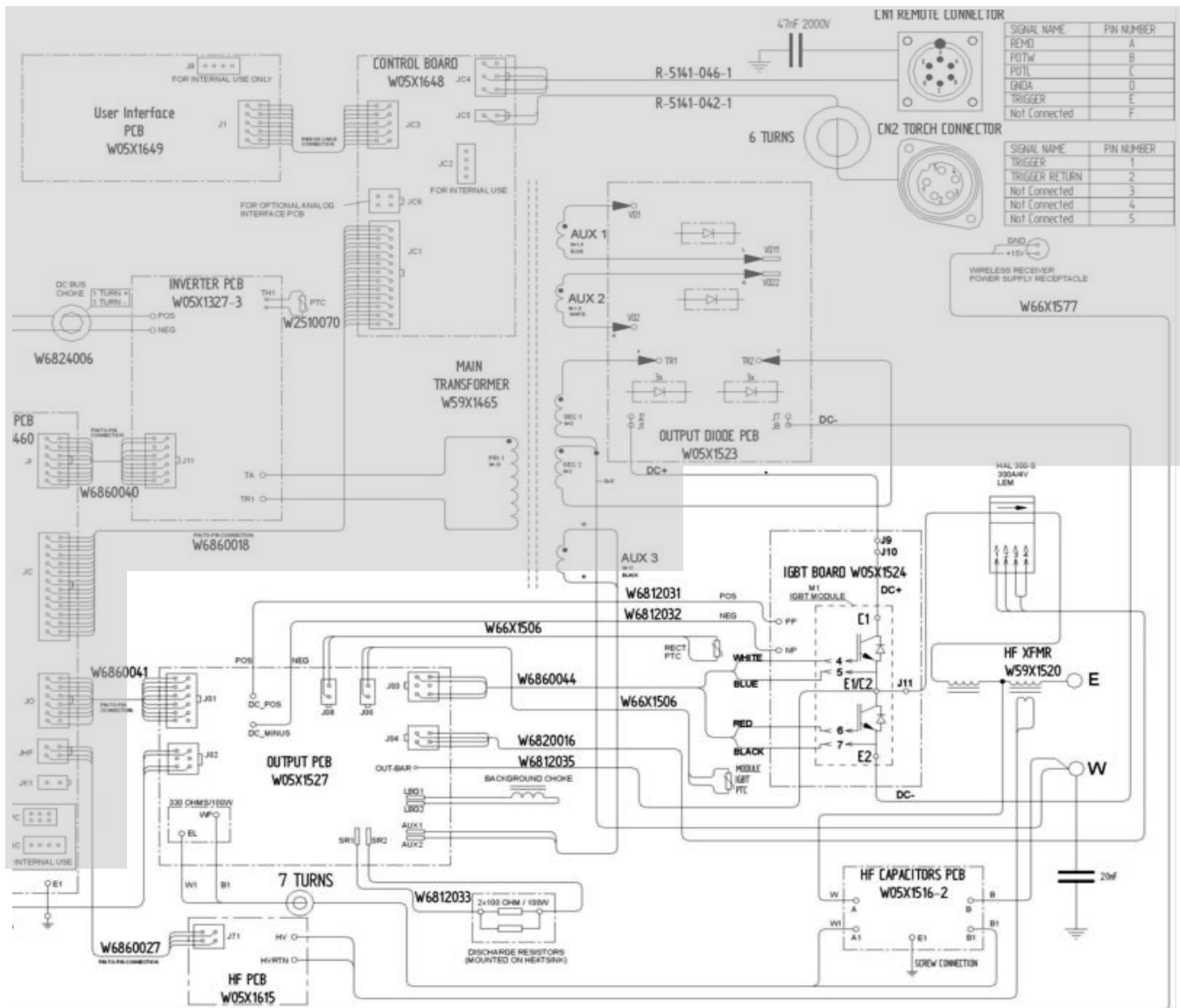

OUTPUT BOARD, IGBT BOARD

The OUTPUT board provides the managing signals and the insulated power supply for the driver of the Output IGBT module. Background circuit necessary for the switching transition in AC mode, is present in this board: 2 amps background current control circuit is present on the output board. The background circuit is supplied by the 75Vdc provided by the input power board. This output board also houses:

- the pre-charge circuit for the snubber capacitor and the active snubber discharge circuit for the power IGBT module used for AC switching.
- The lift tig arc starting detection

On the Output PCB is also connected the output current transducer. The output current feedback is passing through this board and through the input control board, where it is rectified, to reach the microprocessor on the control PCB.

To the IGBT board is connected the IGBT module. The IGBT board receives the driver signals from the Output Board and depending on which of the two IGBTs is active at any given moment the welding

output of the machine can be either DC positive, DC negative or AC.

HF BOARD, HF TRANSFORMER

The HF Board generates a set of 97Hz pulses of about 1000V. These pulses are applied to the high voltage/frequency transformer that is located in the negative welding output leg of the machine and are amplified to about 10KV.

This high frequency/voltage pulse is transferred to the TIG torch via the high frequency transformer.

This allows the remote starting of the TIG arc without the need for the tungsten electrode to touch the work. This high frequency pulse is switched off when the welding arc is established.

The HF command signals are received from the microprocessor on the Control Board and stays on, if the welding arc is not established for about 3 seconds maximum. The HF Board is supplied from the input power board with 24Vdc and 15Vdc. HF is disable in Stick and Lift TIG modes.

CONTROL AND USER INTERFACE BOARD (code 52125)

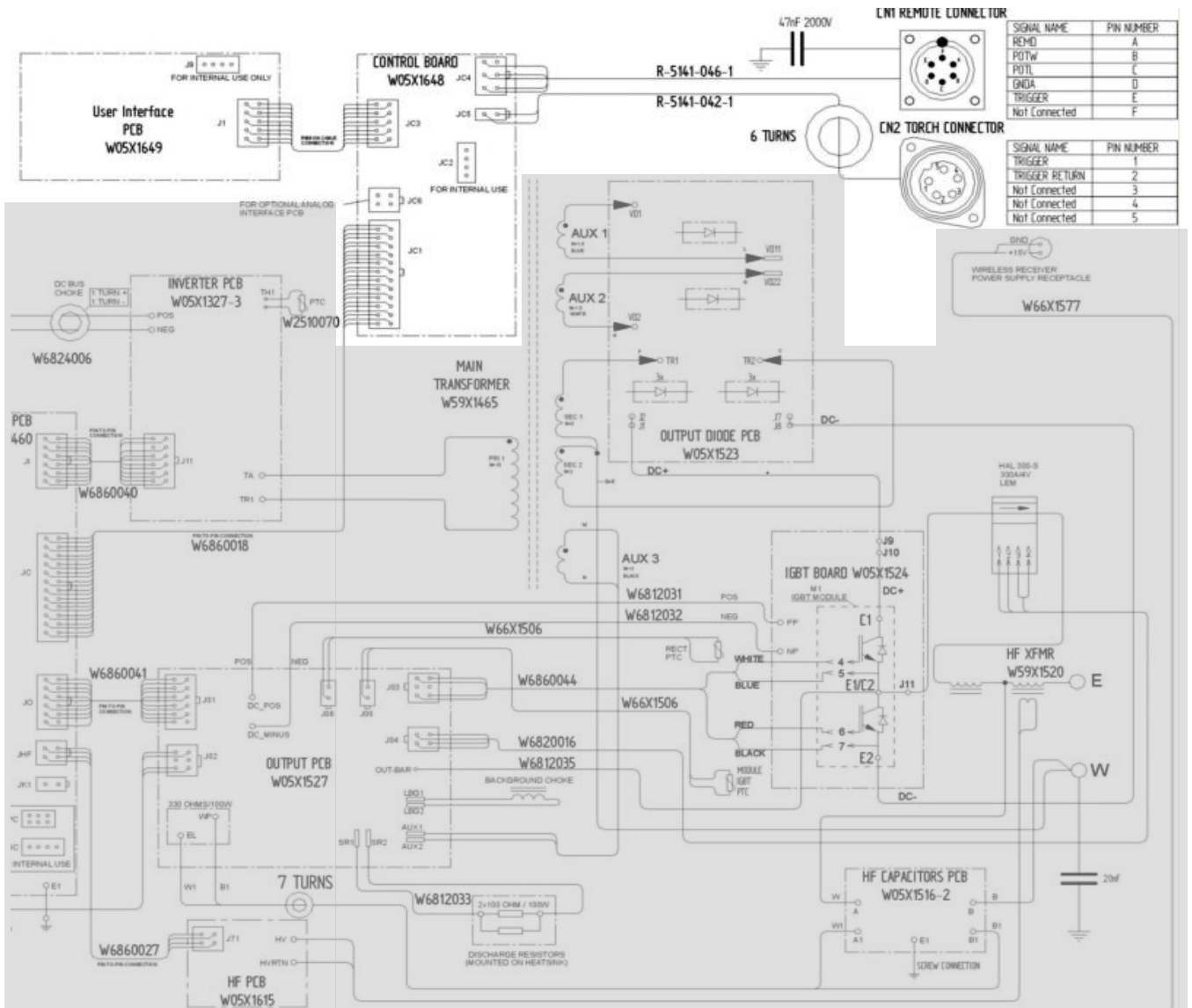

CONTROL AND USER INTERFACE BOARD

The User Interface board houses the control panel, LEDs, push buttons, encoder and functions as the interface between the user and the ASPECT™ 300 machine.

The Control Board managing all the functions of the machine, a micro processor is present on it to make the correct operation. The Control Board receives signals and power from Input Control board and selecting parameters from the User Interface creating the reference signal for the inverter and the driver signals for the output IGB module.

The control Board boards is also responsible to generate the selected AC waveform (Triangular, Square, Sinusoidal or Soft) for AC welding and

to generate the wished DC waveform (like, pulse , upslope, downslope,...).

Control Board and User interface communicate via serial bus.

The Control Board supplies power for the User Interface Board and supplies signals to the User Interface to show set and actual current values, error codes and pre-set values. It also receives signals from the TIG torch connector (pin 1 & 2) or remote connector (pin D & E) to initiate the welding output. The remote control signals (Pins A, B & C) are also fed into the Control Board from the 6 pin connector located on the front of the machine.

Control board communicated by a different serial bus to the input control board mainly for information about input voltage status.

CONTROL AND USER INTERFACE BOARD (code 50595)

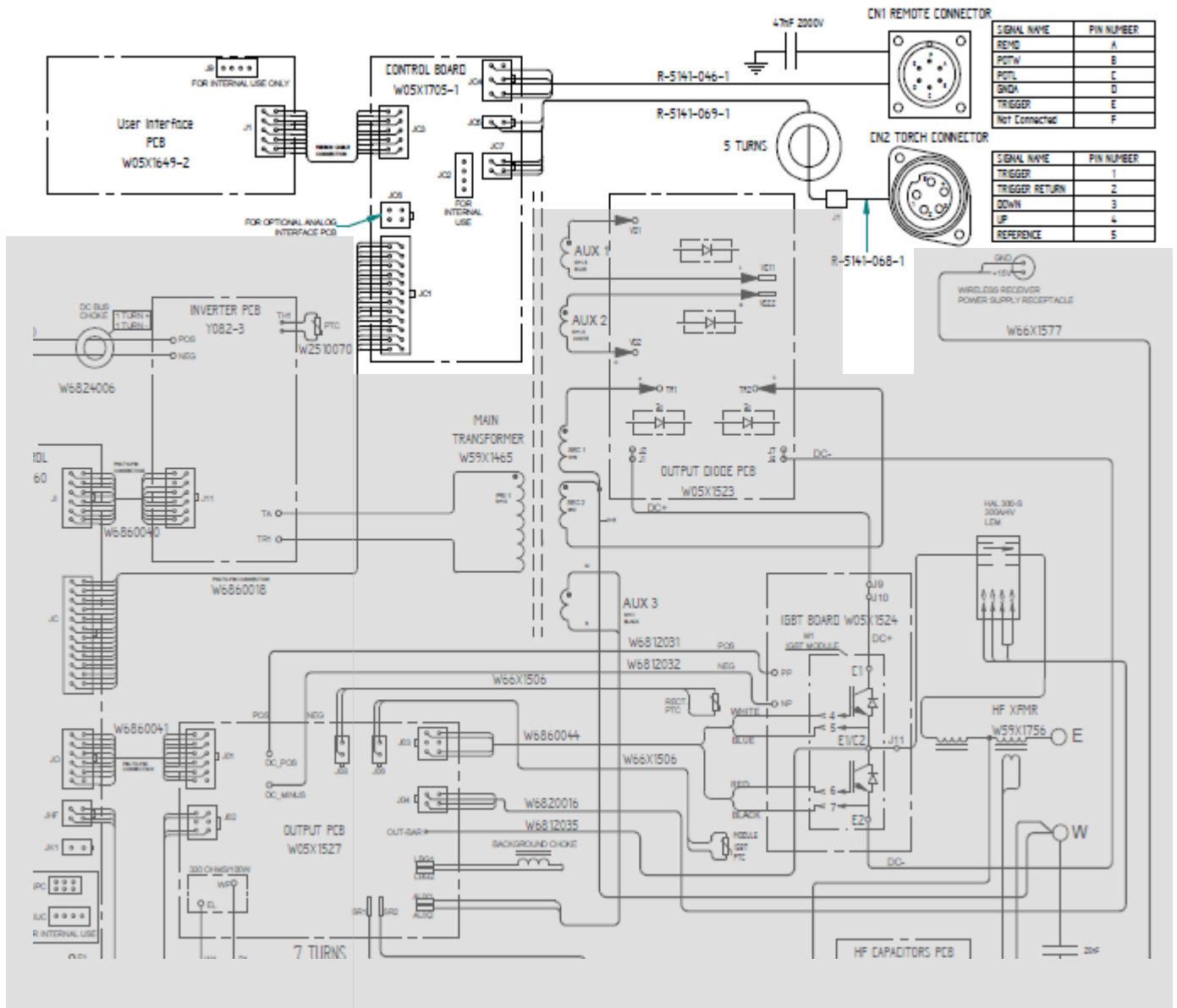

CONTROL AND USER INTERFACE BOARD

The User Interface board houses the control panel, LEDs, push buttons, encoder and functions as the interface between the user and the ASPECT™300 machine.

The Control Board managing all the functions of the machine, a micro processor is present on it to make the correct operation. The Control Board receives signals and power from Input Control board and selecting parameters from the User Interface creating the reference signal for the inverter and the driver signals for the output IGB module.

The control Board boards is also responsible to generate the selected AC waveform (Triangular, Square, Sinusoidal or Soft) for AC welding and

to generate the wished DC waveform (like, pulse , upslope, downslope,...).

Control Board and User interface communicate via serial bus.

The Control Board supplies power for the User Interface Board and supplies signals to the User Interface to show set and actual current values, error codes and pre-set values. It also receives signals from the TIG torch connector (pin 1 & 2 for Trigger and 3,4,&5 for UP/down function) or remote connector (pin D & E) to initiate the welding output. The remote control signals (Pins A, B & C) are also fed into the Control Board from the 6 pin connector located on the front of the machine.

Control board communicated by a different serial bus to the input control board mainly for information about input voltage status.

OVERLOAD PROTECTION

ASPECT™300 is electrically protected from producing higher than normal output currents. An electronic protection circuit limits the current to within the capabilities of the machine.

THERMAL PROTECTION

Thermal Protection Devices protect the machine from excessive operating temperatures.

Excessive temperature may be caused by a lack of cooling air or by operating the machine beyond the duty cycle and output rating. If excessive operating temperature should occur, the Thermal LED indicator on the User Interface board, will turn ON and the thermostat will prevent output current.

The thermal protection device is self-resetting once the machine cools sufficiently. If the shut down was caused by excessive output or duty cycle and the fan is operating normally, the power switch may be left on and the reset should occur within about 15 minute period. If the fan is not turning or the air intake louvers are obstructed, the input power must be removed and the fan problem or air obstruction must be corrected.

INSULATED GATE BIPOLAR TRANSISTOR (IGBT) OPERATION

An IGBT is a type of transistor. IGBTs are semiconductors well suited for high frequency switching and high current applications. Drawing A shows an IGBT in a passive mode. There is no gate signal, zero volts relative to the source, and therefore, no current flow. The drain terminal of the IGBT may be connected to a voltage supply; but since there is no conduction the circuit will not supply current to components connected to the source. The circuit is turned off like a light switch in the OFF position.

Drawing B shows the IGBT in an active mode. When the gate signal, a positive DC voltage relative to the source, is applied to the gate terminal of the IGBT, it is capable of conducting current. A voltage supply connected to the drain terminal will allow the IGBT to conduct and supply current to circuit components coupled to the source. Current will flow through the conducting IGBT to downstream components as long as the positive gate signal is present. This is similar to turning ON a light switch

IGBT

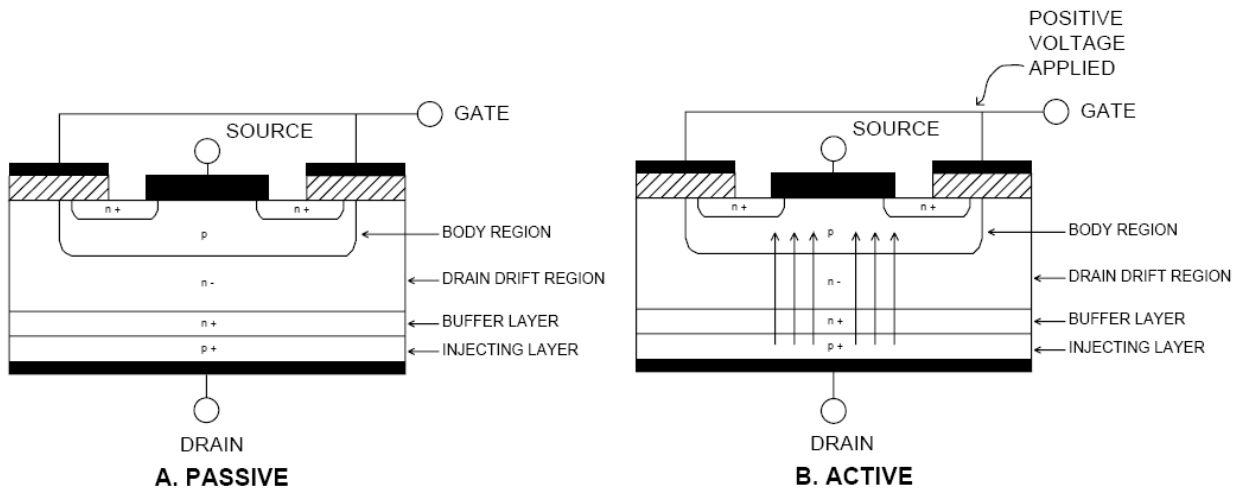

TROUBLESHOOTING AND REPAIR SECTION

- How to use troubleshooting Guide
- Troubleshooting Guide
- Case cover removal and capacitor discharge procedure
- EMC Filter Board test
- Input Rectifier test
- Buck/Boost Board test
- Input Power board test
- Input Control board test
- Inverter board resistance and voltage test
- Output board test
- Output Diode board resistance test
- IGBT board resistance test
- HF board test
- Control board and User Interface board test
- Gas solenoid test

HOW TO USE TROUBLESHOOTING GUIDE

Service and repair should be performed by only Lincoln Electric Factory Trained Personnel. Unauthorized repairs performed on this equipment may result in danger to the technician and machine operator and will invalidate your factory warranty. For your safety and to avoid Electrical Shock, please observe all safety notes and precautions detailed throughout this manual.

.....

This Troubleshooting Guide is provided to help you locate and repair possible machine malfunctions. Simply follow the three-step procedure listed below.

Step 1. LOCATE PROBLEM (SYMPTOM). Look under the column labeled "PROBLEMS". This column describes possible symptoms that the machine may exhibit. Find the listing that best describes the symptom that the machine is exhibiting. Symptoms are grouped into three main categories: Output Problems, Function Problems, and LED Function Problems.

Step 2. PERFORM EXTERNAL TESTS. The second column, labeled "CHECKS", lists the obvious external possibilities that may contribute to the machine symptom. Perform these tests/checks in the order listed. In general, these tests can be conducted without removing the case wrap-around cover.

Step 3. PERFORM COMPONENT TESTS. The last column, labeled "RECOMMENDED COURSE OF ACTION" lists the most likely components that may have failed in your machine. It also specifies the appropriate test procedure to verify that the subject component is either good or bad. If there are a number of possible components, check the components in the order listed to eliminate one possibility at a time until you locate the cause of your problem.

All of the referenced test procedures referred to in the Troubleshooting Guide are described in detail at the end of this chapter. Refer to the Troubleshooting and Repair Table of Contents to locate each specific Test Procedure. All of the referred to test points, components, terminal strips, etc., can be found on the referenced electrical wiring diagrams and schematics. Refer to the Wiring Diagrams Section Table of Contents to locate the appropriate diagram.

WARNING



ELECTRIC SHOCK can kill

- Have an electrician install and service this equipment
- Turn the input power off at the fuse box before working on equipment
- Do not touch electrically hot parts
- Prior to performing preventive maintenance, perform the following capacitor discharge procedure to avoid electric shock

Sometimes machine failures appear to be due to PC board failures. These problems can sometimes be traced to poor electrical connections. To avoid problems when troubleshooting and replacing PC boards, please use the following procedure:

1. Determine to the best of your technical ability that the PC board is the most likely component causing the failure symptom.
2. Check for loose connections at the PC board to assure that the PC board is properly connected.
3. If the problem persists, replace the suspect PC board using standard practices to avoid static electrical damage and electrical shock.
4. Test the machine to determine if the failure symptom has been corrected by the replacement PC board.



NOTE: Allow the machine to heat up so that all electrical components can reach their operating temperature.

5. Remove the replacement PC board and substitute it with the original PC board to recreate the original problem.
 - If the original problem does not reappear by substituting the original board, then the PC board was not the problem. Continue to look for bad connections in the control wiring harness, junction blocks, and terminal strips.
 - If the original problem is recreated by the substitution of the original board, then the PC board was the problem. Reinstall the replacement PC board and test the machine.
6. Always indicate that this procedure was followed when warranty reports are to be submitted.

NOTE: Following this procedure and writing on the warranty report, "INSTALLED AND SWITCHED PC BOARDS TO VERIFY PROBLEM," will help avoid denial of legitimate PC board warranty claims.

TROUBLESHOOTING

!! WARNING !! BEFORE CONNECT POWER SUPPLY, MAKE A CAREFUL VISUAL INSPECTION INSIDE THE MACHINE , CHECK ALL THE BOARDS AND HARNESS.

PROBLEMS / SYMPTOMS	CHECKS / ERROR DESCRIPTION	RECOMMENDED COURSE OF ACTION
A VISUAL DAMAGE IS EVIDENT WHEN YOU OPEN THE COVER	-----	<ul style="list-style-type: none"> CHANGE THE BROKEN PART AND PERFORM THE TESTS FOR THE OTHER MACHINE COMPONENTS*
MACHINE IS DEAD, NO LED, NO FAN	<ul style="list-style-type: none"> MAKE SURE THAT THE INPUT LINE IS PRESENT CHECK THE INPUT SWITCH PERFORM THE EMC BOARD TEST AND INPUT POWER BOARD TEST 	<ul style="list-style-type: none"> CONNECT THE INPUT LINE REPLACE THE INPUT SWITCH IF NECESSARY* REPLACE THE EMC BOARD OR INPUT POWER BOARD IF NECESSARY*
THE MAIN INPUT FUSES OR BREAKERS REPEATEDLY FAIL	<ul style="list-style-type: none"> MAKE CERTAIN THE FUSES OR BREAKERS ARE PROPERLY SIZED FOR THE INPUT DRAW OF THE MACHINE. SEE MACHINE RATING PLATE OR TECHNICAL SPECIFICATION AVAILABLE IN THIS SERVICE MANUAL 3PH INPUT BRIDGE OR ONE OF THE MACHINE PRIMARYSIDE CIRCUITS MAY BE FAULTY 	<ul style="list-style-type: none"> USE CORRECT SIZE OF FUSES OR CIRCUIT BREAKER PERFORM THE 3PH INPUT BRIDGE* PERFORM THE BUCK/BOOST TEST* PERFORM THE CAPS BOARD TEST* PERFORME THE INVERTER TEST*
THE THERMAL LED IS LIT PERMANENTLY	<ul style="list-style-type: none"> ONE OF THE MACHINE THERMAL SENSOR IS DEFECT. THE INPUT CONTROL BOARD IS DEFECT THE CONTROL BOARD IS DEFECT 	<ul style="list-style-type: none"> CHECK THE THERMAL SENSORS* CHECK THE HARNESS OF THE THERMAL SENSORS* PERFORM THE INPUT CONTROL BOARD TEST* PERFORM THE CONTROL BOARD TEST*
 LEDs ON THE FRONT PANEL IS BLINKING AND ERROR 01 OR ERROR 02 IS DISPLAYED.	<ul style="list-style-type: none"> INDICATES THAT AN INPUT UNDERVOLTAGE OR OVERVOLTAGE PROTECTION IS ACTIVE. THE MACHINE RESTARTS AUTOMATICALLY WHEN THE INPUT VOLTAGE RETURNS IN THE CORRECT RANGE, IF THE ERROR PERSISTS FOLLOW THE RECOMMENDED TESTS 	<ul style="list-style-type: none"> CHECK THE VALUE OF THE INPUT VOLTAGE , MUST BE 230VAC OR 400VAC +/- 15% PERFORM THE EMC FILTER TEST* PERFORM THE INPUT POWER BOARD TEST*
 LEDs ON THE FRONT PANEL BLINKING AND ERROR 03 IS DISPLAYED.	<ul style="list-style-type: none"> INDICATES THAT THE MACHINE IS INCORRECTLY CONNECTED TO THE SUPPLY LINE 	<ul style="list-style-type: none"> CHECK THAT ALL OF THE 3 PHASES ARE ARRIVING TO THE 3PH INPUT BRIDGE* PERFORM THE EMC FILTER BOARD TEST*
 LEDs ON THE FRONT PANEL BLINKING AND ERROR 06 IS DISPLAYED.	<ul style="list-style-type: none"> INVERTER AUXILIARY VOLTAGE FAULT CONDITION DETECTED 	<ul style="list-style-type: none"> PERFORM THE INPUT POWER BOARD TEST (FOCUS ON AUXILIARY VOLTAGE +15VDC)*
ERROR 12 IS DISPLAYED	<ul style="list-style-type: none"> IGBT OUTPUT SWITCH MODULE OVERLOAD VOLTAGE 	<ul style="list-style-type: none"> PERFORM THE OUTPUT CONTROL BOARD TEST* VERIFY THE ISOTOP RESISTOR CONNECTED TO SR1 AND SR2 ON THE OUTPUT CONTROL BOARD*
THE WATER COOLER (IF CONNECTED) IS NOT WORKING. ERROR 11 IS DISPLAYED.	<ul style="list-style-type: none"> PERFORM THE INPUT CONTROL BOARD TEST; FOCUS ON JIP_W AND JW CONNECTORS TO CHECK IF WATER COOLER POWER SUPPLY IS PRESENT CHECK FUSE "FS1" ON INPUT CONTROL BOARD 	<ul style="list-style-type: none"> IF POWER SUPPLY IS PRESENT AT JIP_W BUT NOT AT JW , REPLACE THE INPUT CONTROL BOARD* IF FUSE "FS1" IS OPEN, REPLACE AND PERFORM THE WATER COOLER TESTS*

* This tests and repair should only be performed by Lincoln Electric Trained Personnel. Unauthorized repairs performed on this equipment may result in danger to the technician and machine operator and will invalidate your factory warranty. For your safety and to avoid Electrical Shock, please observe all safety notes and precautions detailed throughout this manual.

CASE COVER REMOVAL AND DC BUS CAPACITOR DISCHARGE PROCEDURE

WARNING

Service and repair should be performed only by Lincoln Electric factory trained personnel. Unauthorized repairs performed on this equipment may result in danger to the technician or machine operator and will invalidate your factory warranty. For your safety and to avoid electrical shock, please observe all safety notes and precautions detailed throughout this manual.

If for any reason you do not understand the test procedures or are unable to perform the test/repairs safely, contact your Local Lincoln Electric Service Department for electrical troubleshooting assistance before you proceed.

.....

DESCRIPTION

This procedure will aid the technician in the removal and replacement of the case sheet metal cover and discharging the DC link capacitor making it safe for the technician to work on the machine.

MATERIALS NEEDED

Phillips screwdriver PH02

ASPECT™300 - CASE COVER REMOVAL

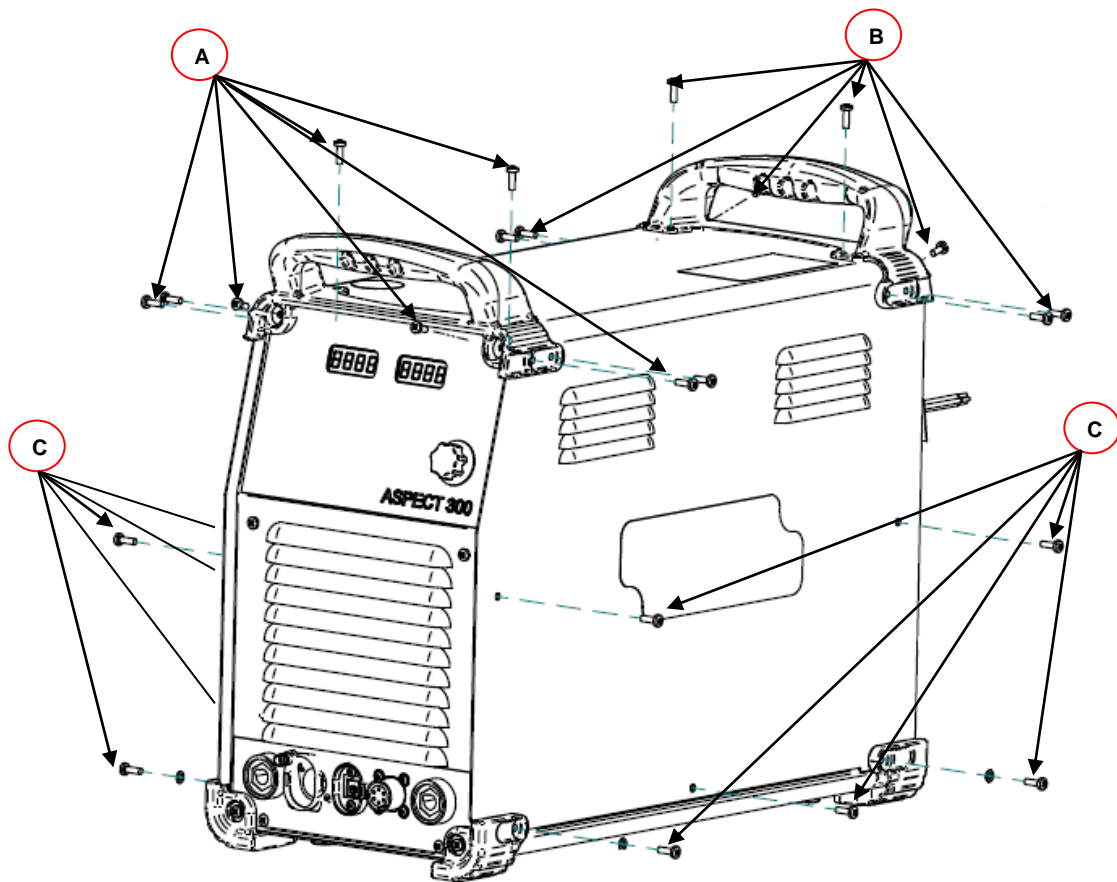

Procedure:

1. Turn ON/OFF switch to OFF position.
2. **Disconnect Input Power from the machine !**
3. Remove the 16 screws of the rear and front plastic handle (8xA & 8xB)
4. Remove the 10 screws from the right and left side of the machine (C).
5. Don't remove the 4 bottom rubber corners
6. Pull up the red case cover taking care of the ground wire connection.
7. Follow the next page for **DC BUS capacitors discharge procedure !**

DC BUS CAPACITORS DISCHARGE PROCEDURE

WARNING



ELECTRIC SHOCK can kill

Have an electrician install and service this equipment
Turn the input power off at the fuse box before working on equipment

Do not touch electrically hot parts

Prior to performing preventive maintenance, perform the following capacitor discharge procedure to avoid electric shock.

INPUT DC BUS CAPACITORS DISCHARGE PROCEDURE

1. Remove input power to the ASPECT™300
2. Remove the cover following the instruction available in this Service manual.
3. Check the voltage across the two terminals. Voltage should be zero. If any voltage remains, apply the following procedure.
4. Obtain a high resistance and high wattage resistor (25-1000 ohms and 25 watts minimum). This resistor is NOT supplied with the machine. NEVER USE A SHORTING STRAP FOR THIS PROCEDURE.
5. Locate the two terminals **DC+** and **DC -** on the Caps Board (See Figure 1).
6. Use electrically insulate gloves and insulated pliers. Hold the body of the resistor and connect the resistor leads across the two terminals. Hold the resistor in place for 10 seconds. DO NOT TOUCH CAPACITOR TERMINALS WITH YOUR BARE HANDS.



Figure 1 – W05X1470 Caps Board

EMC FILTER BOARD TEST

WARNING

Service and repair should be performed by only Lincoln Electric factory trained personnel. Unauthorized repairs performed on this equipment may result in danger to the technician or machine operator and will invalidate your factory warranty. For your safety and to avoid electrical shock, please observe all safety notes and precautions detailed throughout this manual. If for any reason you do not understand the test procedures or are unable to perform the test/repairs safely, contact your Local Lincoln Electric Service Department for electrical troubleshooting assistance before you proceed.

.....

TEST DESCRIPTION

This test will determine if the EMC Filter board has failed.

MATERIALS NEEDED

Volt/Ohmmeter
Schematic X1471

EMC FILTER BOARD TES (continued)

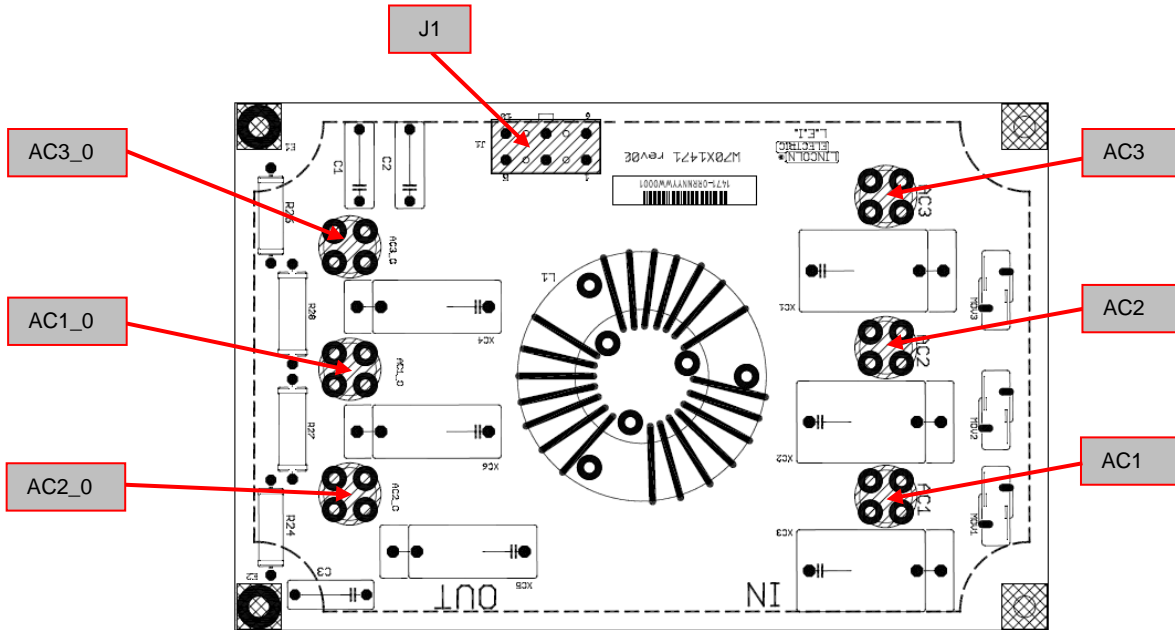

Figure 2 – W05X1471 – EMC FILTER BOARD

TEST PROCEDURE

⚠ Use always electrically insulate gloves during this test procedure

1. Remove main input power to the ASPECT™300
2. Perform the **Case removal** and **Discharge procedure**
3. Locate the EMC Filter Board W05X1547 (see major components location available in this manual).
4. Visually check for burned or damaged components. If any components are physically damaged the EMC Filter board should be replaced
5. Using the Volt-Ohmmeter (ohm mode) perform the tests as indicated in **Test Table 1**. See **Figure 2** for correct test points location.
6. Carefully apply the correct input voltage 230Vac/3ph +/-15% or 400Vac/3ph +/-15% via the input cable to the ASPECT™300.
7. Switch to ON position the main switch and using the voltmeter in AC mode perform the tests as indicated in **Test Table 2**. See **Figure 2** for correct test points location.
8. If any of the tests listed on Test Tables are not correct the EMC Filter Board may be faulty. Please follow the EMC Filter Board removal and replacement procedure.

Test Table 1 - EMC Filter Board Resistance Tests

Positive Probe (RED)	Negative Probe (BLACK)	Value
AC1	AC1_0	0 (zero) ohm
AC2	AC2_0	0 (zero) ohm
AC3	AC3_0	0 (zero) ohm
AC1	J1/3 and J1/8	0 (zero) ohm
AC2	J1/1 and J1/6	0 (zero) ohm
AC3	J1/5 and J1/10	0 (zero) ohm

Test Table 2 - EMC Filter Board Voltage Tests

Positive Probe (RED)	Negative Probe (BLACK)	Value (Machine connected to 230Vac/3ph)	Value (Machine connected to 400Vac/3ph)
AC1	AC2	230Vac +/-15%	400Vac +/- 15%
AC1	AC3	230Vac +/-15%	400Vac +/- 15%
AC1_0	AC2_0	230Vac +/-15%	400Vac +/- 15%
AC1_0	AC3_0	230Vac +/-15%	400Vac +/- 15%
J1/3 and J1/8	J1/1 and J1/6	230Vac +/-15%	400Vac +/- 15%
J1/3 and J1/8	J1/5 and J1/10	230Vac +/-15%	400Vac +/- 15%

INPUT RECTIFIER TEST

WARNING

Service and repair should be performed by only Lincoln Electric factory trained personnel. Unauthorized repairs performed on this equipment may result in danger to the technician or machine operator and will invalidate your factory warranty. For your safety and to avoid electrical shock, please observe all safety notes and precautions detailed throughout this manual. If for any reason you do not understand the test procedures or are unable to perform the test/repairs safely, contact your Local Lincoln Electric Service Department for electrical troubleshooting assistance before you proceed.

.....

TEST DESCRIPTION

This test will determine if the Input Rectifier Bridge has failed.

MATERIALS NEEDED

Volt/Ohmmeter
Machine Wiring Diagram

INPUT RECTIFIER TEST (continued)

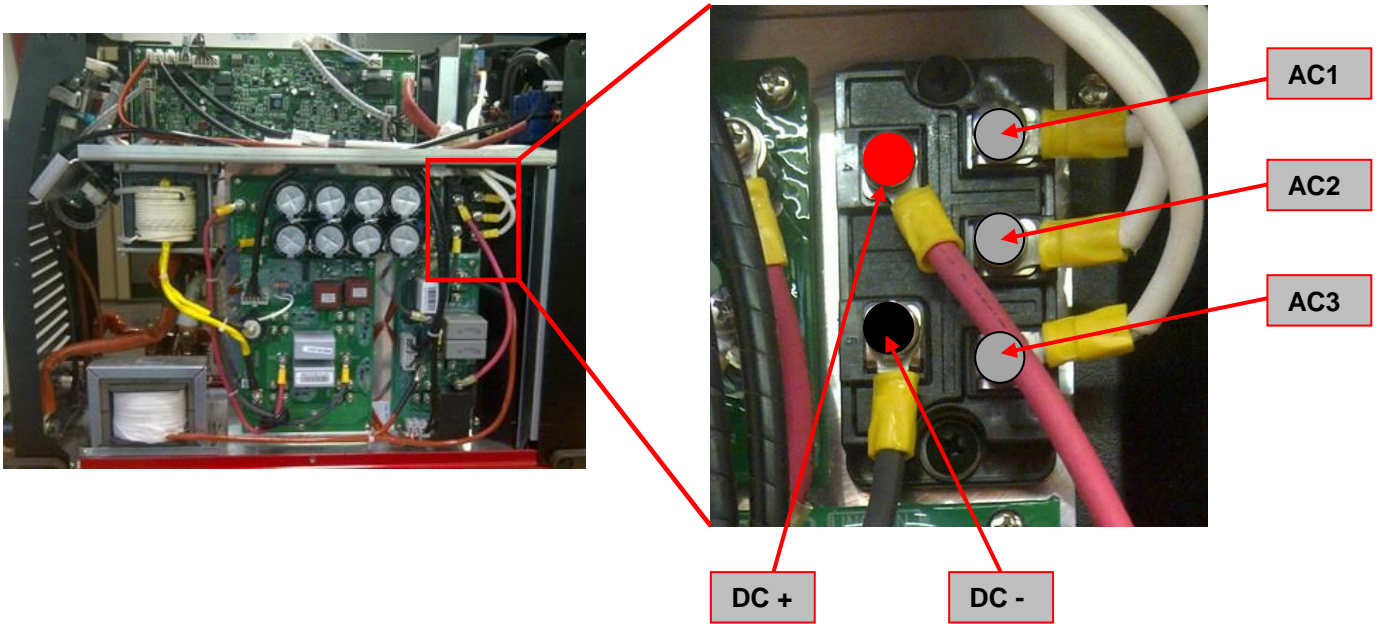

Figure 3 – Input Rectifier Bridge location and Test Points

TEST PROCEDURE

⚠ Use always electrically insulate gloves during this test procedure

1. Remove main input power to the ASPECT™300.
2. Perform the **Case removal** and **Discharge procedure**
3. Locate the Input Rectifier Bridge on the right side of the machine. See **Figure 3**.
4. Perform the tests as detailed in **Test table 3**. See also **Figure 3** for terminals locations.
5. If the tests results are questionable, label and remove all of the leads from the Input Rectifier Bridge and re-test.
6. If any portion of the test fails, the input rectifier may be faulty and must be replaced.

Test table 3 – Input Rectifier Bridge Test

<i>Positive Probe (RED)</i>	<i>Negative Probe (BLACK)</i>	<i>Value</i>
Terminal AC1	Terminal DC+	0.3 - 1.0V Forward Diode Drop
Terminal AC2	Terminal DC+	0.3 - 1.0V Forward Diode Drop
Terminal AC3	Terminal DC+	0.3 - 1.0V Forward Diode Drop
Terminal DC-	Terminal AC1	0.3 - 1.0V Forward Diode Drop
Terminal DC-	Terminal AC2	0.3 - 1.0V Forward Diode Drop
Terminal DC-	Terminal AC3	0.3 - 1.0V Forward Diode Drop

BUCK/BOOST BOARD TEST

WARNING

Service and repair should be performed by only Lincoln Electric factory trained personnel. Unauthorized repairs performed on this equipment may result in danger to the technician or machine operator and will invalidate your factory warranty. For your safety and to avoid electrical shock, please observe all safety notes and precautions detailed throughout this manual. If for any reason you do not understand the test procedures or are unable to perform the test/repairs safely, contact your Local Lincoln Electric Service Department for electrical troubleshooting assistance before you proceed.

.....

TEST DESCRIPTION

This test will aid the technician to determine if the Buck/Boost Board is receiving the correct input voltages and if the Buck/Boost board is producing the correct output voltage to the Inverter Board. It will also determine if the soft-start relay coil is good. The outputs and input voltages between the Input Control Board and the Buck/Boost Board will also be tested. This test will NOT determine the functionality of the entire board.

MATERIALS NEEDED

Volt/Ohmmeter
Phillips screwdriver
Schematic X0982 for code 52125
Schematic X0982-2 for code 50595

BUCK/BOOST BOARD TEST (continued)

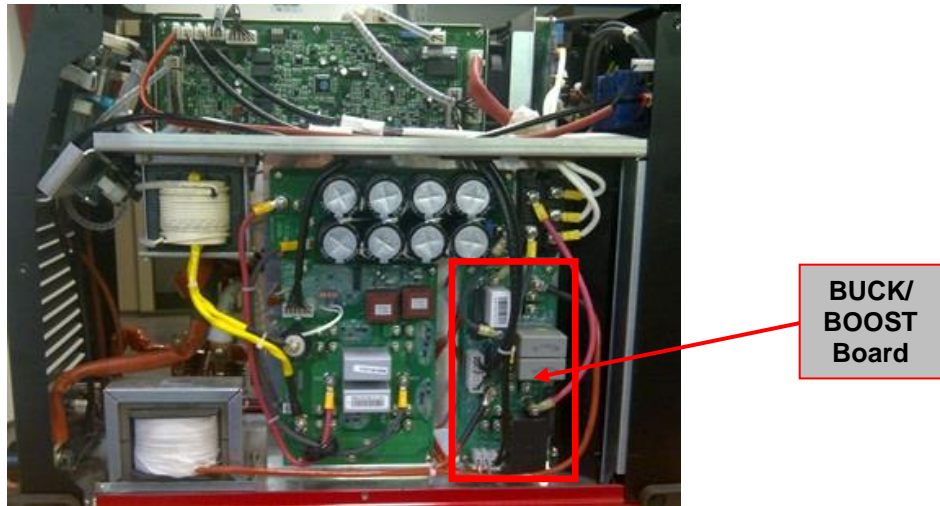

Figure 4 – W05X0982-1 & W05X0982-2 BUCK/BOOST Board location

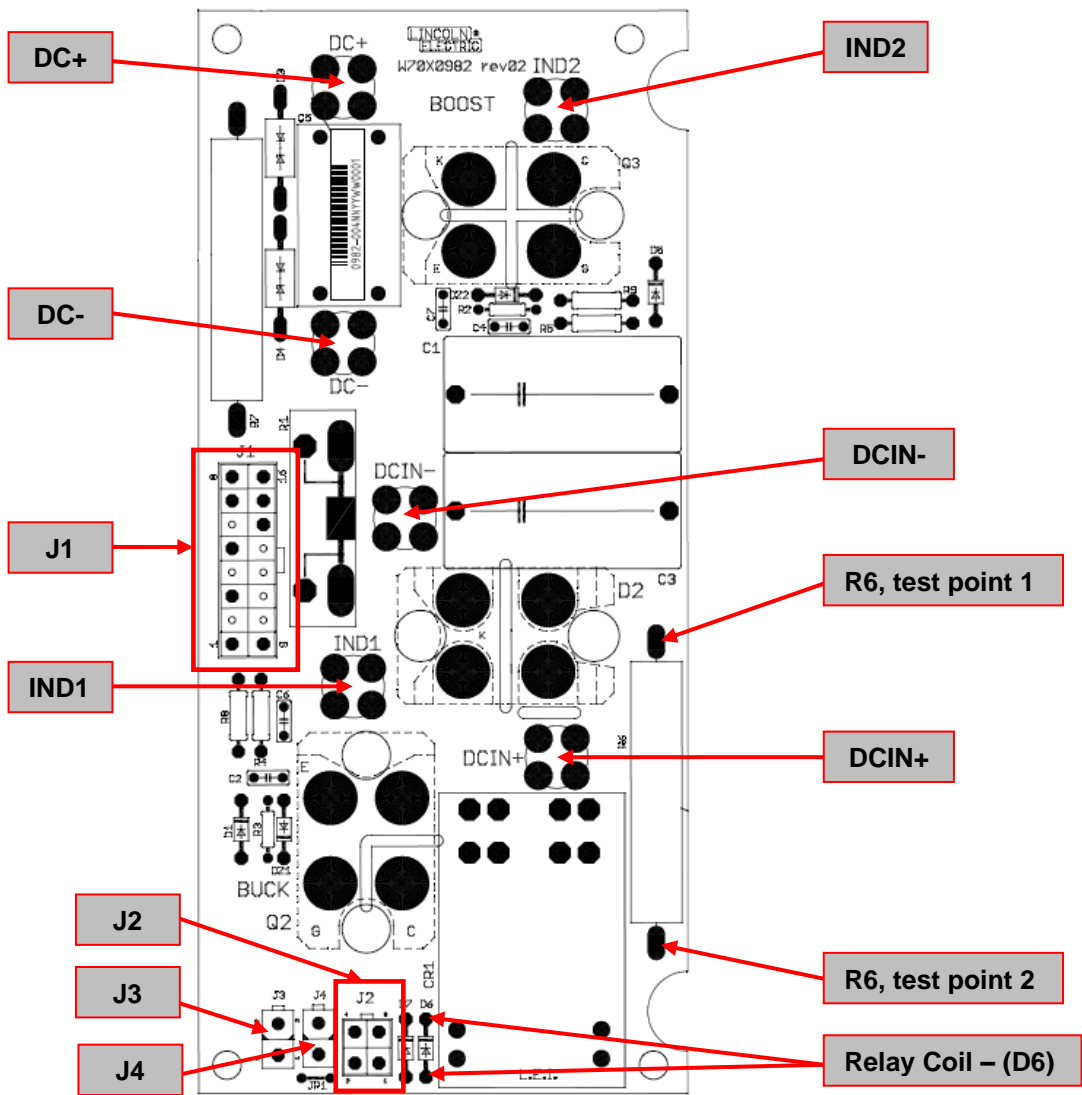

Figure 5 – W05X0982-1 & W05X0982-2 BUCK/BOOST Board Test

BUCK/BOOST BOARD TEST (continued)

TEST PROCEDURE

⚠ Use always electrically insulate gloves during this test procedure

1. Remove main input power to the ASPECT™300.
2. Perform the **Case removal and Discharge procedure**
3. Locate the Buck/Boost board on the right side of the machine. See **Figure 4**.
4. Visually check for burned or damaged components. If any components are physically damaged the Buck/Boost board should be replaced
5. Perform the resistance and voltage tests detailed in **Test Table 4** and **Test Table 5**. See **Figure 5** for Test Point locations

Test table 4 – BUCK/BOOST - Resistance Tests

<i>Machine condition</i>	<i>Test Points</i>	<i>Expected reading</i>	<i>Note</i>
Machine disconnected from input voltage and capacitors discharged.	IND1 to IND2	Zero Ohms	Continuity of input choke
Machine disconnected from input voltage and capacitors discharged	R6 Test Point 1 to R6 Test Point 2	90 to 100 Ohms	Soft-Start Resistor. If a very low resistance is indicated the soft start relay contacts may be stuck closed.
Machine disconnected from input voltage and capacitors discharged	Relay Coil Test Points (D6)	350 Ohms +/- 10%	Soft-Start relay coil resistance check.
Machine disconnected from input voltage and capacitors discharged	IND2 (positive test probe) to DC- (negative test probe)	Open (Test Diode mode)	<u>Measurement taken with the leads disconnected from test points.</u> If short circuit is found the boost transistor may be damaged. Replace the Buck/Boost board.
Machine disconnected from input voltage and capacitors discharged	IND2 (negative test probe) to DC- (positive test probe)	Forward diode drop (Test Diode mode)	<u>Measurement taken with the leads disconnected from test points.</u> If a short circuit is found the boost transistor may be damaged. Replace the Buck/Boost board.
Machine disconnected from input voltage and capacitors discharged	R6 Test Point 1 (positive test probe) to IND1 (negative test probe)	Open (Test Diode mode)	If a short circuit is found the buck transistor may be damaged. Replace the Buck/Boostboard
Machine disconnected from input voltage and capacitors discharged	R6 Test Point 1 (negative test probe) to IND1 (positive test probe)	Forward diode drop (Test Diode mode)	If a short circuit is found the buck transistor may be damaged. Replace the Buck/Boost board.
Machine disconnected from input voltage and capacitors discharged	Plug J4 pin1 to J4 pin2	60-70 Ohm +/-20% @20°C	Boost PTC
Machine disconnected from input voltage and capacitors discharged	Plug J3 pin1 to J3 pin 2	50-60 Ohm +/-20% @20°C	Buck PTC

Test table 5 – BUCK/BOOST - Voltage Tests

<i>Machine AC input voltage</i>	<i>Test Points</i>	<i>Expected reading</i>	<i>Note</i>
400Vac	DCIN+ to DCIN-	560Vdc +/-15%	Input voltage to buck/boost circuit. Machine powered, no load
400Vac / 230Vac	DC+ to DC-	400Vdc	Filtered output of buck/boost circuit.
400Vac / 230Vac	Plug J2 Pin 3(+) to Pin 1(-)	24 Vdc	Present when soft-start is completed. Machine powered, no load
400Vac	Plug J1 Pin 1(+) to Pin 9(-)	+15V/20kHz (oscilloscope needed)	Buck drive signal from Input Control board. Machine powered, no load
230Vac	Plug J1 Pin 1(+) to Pin 9(-)	+15Vdc	Buck drive signal from Input Control board. Machine powered, no load
400Vac	Plug J1 Pin 8(+) to Pin 7(-)	0 Vdc	Boost drive signal from Input Control board. Machine powered, no load
230Vac	Plug J1 Pin 8(+) to Pin 7(-)	+15V/20kHz (oscilloscope needed)	Boost drive signal from Input Control board. Machine powered, no load

INPUT POWER BOARD TEST

WARNING

Service and repair should be performed by only Lincoln Electric factory trained personnel. Unauthorized repairs performed on this equipment may result in danger to the technician or machine operator and will invalidate your factory warranty. For your safety and to avoid electrical shock, please observe all safety notes and precautions detailed throughout this manual. If for any reason you do not understand the test procedures or are unable to perform the test/repairs safely, contact your Local Lincoln Electric Service Department for electrical troubleshooting assistance before you proceed.

.....

TEST DESCRIPTION

This test will help to determine if the Input Power board is providing all the correct auxiliary voltages to the machine boards.

MATERIALS NEEDED

Volt/Ohmmeter
Schematic X1461

INPUT POWER BOARD TEST (continued)



Figure 6 – W05X1461 INPUT POWER Board location

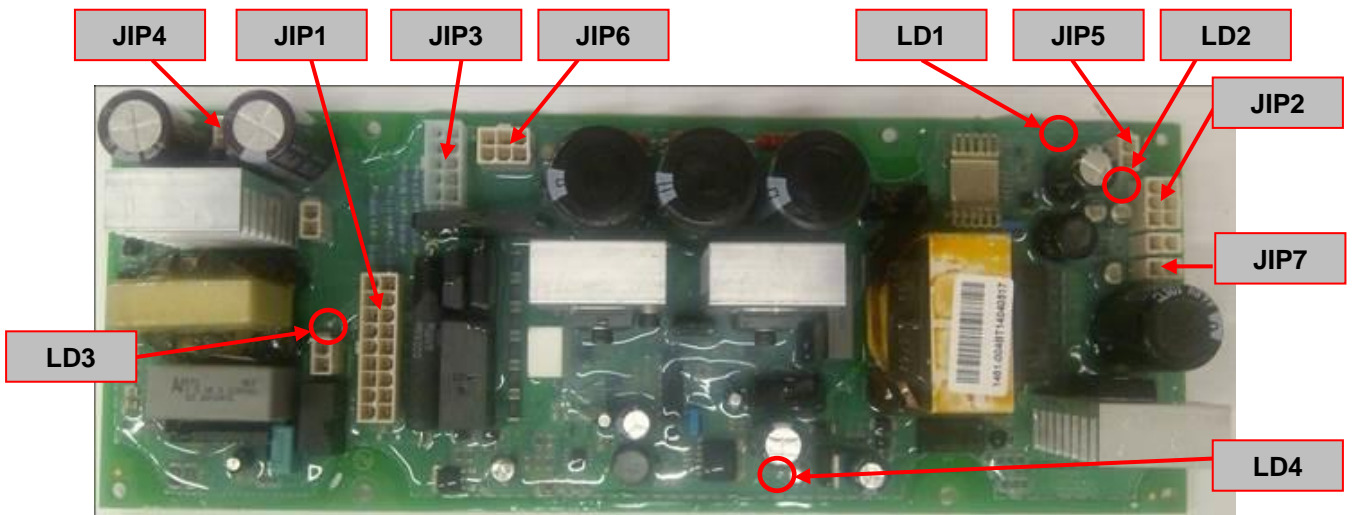
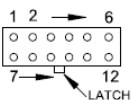

Figure 7 – W05X1461 INPUT POWER Board Test Points

CONNECTOR PIN NUMBERS:

EX. 12 PIN CONNECTOR



VIEW OF CONNECTOR ON PC BOARD

INPUT POWER BOARD TEST (continued)

TEST PROCEDURE

 **Use always electrically insulate gloves during this test procedure**

1. Remove main input power to the ASPECT™300.
2. Perform the **Case removal** and **Discharge procedure**
3. Locate the Input Power Board on the upper left side of the machine. See **Figure 6**.
4. Visually check for burned or damaged components. If any components are physically damaged the Input Power board should be replaced
5. Carefully apply 400Vac-3ph +/-15% or 230Vac-3ph +/-15% via the input cable to the ASPECT™300, switch ON the machine and wait till the power LED on front panel is steady green.
6. Perform the voltage tests detailed in **Test Table 6**. See **Figure 7** for Test Point locations

Test table 6 – INPUT POWER BOARD - Voltage Tests

<i>Machine AC input voltage</i>	<i>Test Points</i>	<i>Expected reading</i>	<i>LEDs status and color</i>	<i>Note</i>
400Vac or 230Vac	Plug JIP3 pin 1&6 to pin 3&8	400Vac or 230Vac	-	AC Input voltage from EMC Filter board
400Vac or 230Vac	Plug JIP3 pin 1&6 to pin 5&10	400Vac or 230Vac	-	AC Input voltage from EMC Filter board
400Vac	Plug JIP1 pin 1(+) to pin 6&15 (-)	115Vdc	-	Rectified AC input Line
400Vac or 230Vac	Plug JIP1 pin 3&12(+) to pin 6&15(-)	400Vdc +/- 1%	-	Vdc BUS feedback from Buck/Boost output
400Vac or 230Vac	Plug JIP1 pin 7(+) to pin 6&15(-)	+15Vdc	-	+15Vdc primary side generated by Input Power Board
400Vac or 230Vac	Plug JIP1 pin 18(+) to pin 9(-)	+15Vdc	LD4 ON Green	+15Vdc insulated for Buck driver, generated by Input Power Board
400Vac or 230Vac	Plug JIP1 pin 16(+) to pin 6&15(-)	+15Vdc	LD3 ON Green	+15Vdc primary side for Boost driver, generated by Input Power Board
400Vac or 230Vac	Plug JIP2 pin 1(+) to pin 2&4 (-)	+24Vdc	-	+24Vdc secondary side generated by the Input Power Board
400Vac or 230Vac	Plug JIP2 pin 3(+) to pin 2&4 (-)	-15Vdc	LD2 ON Green	-15Vdc secondary side generated by the Input Power Board
400Vac or 230Vac	Plug JIP2 pin 5(+) to pin 2&4 (-)	+4,5 Vdc	-	Input Power Board (Q1) thermal signal to Input control board
400Vac or 230Vac	Plug JIP2 pin 6(+) to pin 2&4 (-)	+15Vdc	LD1 ON Green	+15Vdc secondary side generated by the Input Power Board
400Vac or 230Vac	Plug JIP4 pin 1&3(+) to pin 2&4(-)	+75Vdc	-	+75Vdc generated by the Input Power Board
400Vac or 230Vac	Plug JIP5 pin 2(+) to pin 1(-)	+15Vdc	LD1 ON Green	+15Vdc secondary side generated by the Input Power Board to supply the wireless receiver
400Vac or 230Vac	Plug JIP7 pin 2(+) to pin 1(-)	+24Vdc	-	+24Vdc secondary side generated by the Input Power Board to supply the small shelf fan
400Vac	Pug JIP6 pin 1&4 to pin 3&6	400Vac	-	Water cooler supply voltage – unit connected to 400Vac
230Vac	Pug JIP6 pin 1&4 to pin 3&6	230Vac	-	Water cooler supply voltage – unit connected to 230Vac

INPUT CONTROL BOARD TEST

WARNING

Service and repair should be performed by only Lincoln Electric factory trained personnel. Unauthorized repairs performed on this equipment may result in danger to the technician or machine operator and will invalidate your factory warranty. For your safety and to avoid electrical shock, please observe all safety notes and precautions detailed throughout this manual. If for any reason you do not understand the test procedures or are unable to perform the test/repairs safely, contact your Local Lincoln Electric Service Department for electrical troubleshooting assistance before you proceed.

.....

TEST DESCRIPTION

This test will help to determine if the Input Control Board is receiving the correct auxiliary voltages and signals and if it provides all the correct signals to the machine boards.

MATERIALS NEEDED

Volt/Ohmmeter
Schematic X1460

INPUT CONTROL BOARD TEST (continued)

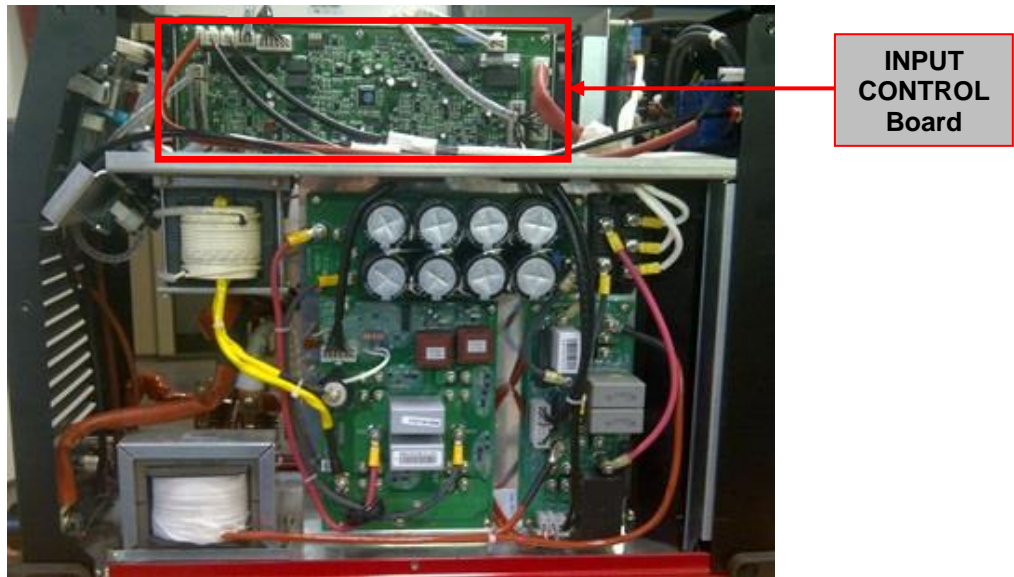

Figure 8 – W05X1460 INPUT CONTROL Board location

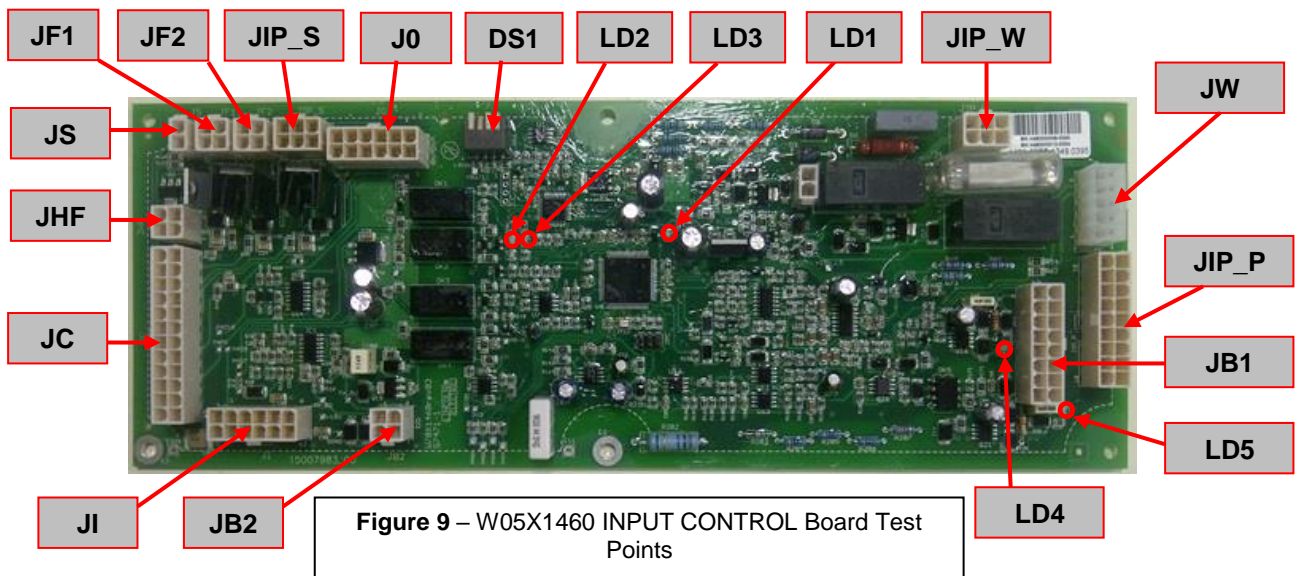
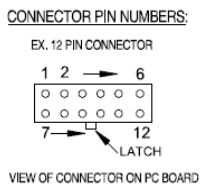

Figure 9 – W05X1460 INPUT CONTROL Board Test Points



INPUT CONTROL BOARD TEST (continued)

TEST PROCEDURE

⚠ Use always electrically insulate gloves during this test procedure

1. Remove main input power to the ASPECT™ 300.
2. Perform the **Case Removal and Discharge procedure**
3. Locate the Input Control Board on the upper right side of the machine. See **Figure 8**.
4. Visually check for burned or damaged components. If any components are physically damaged the Input Control board should be replaced
5. Carefully apply 400Vac/3ph +/-15% or 230Vac-3ph +/-15% via the input cable to the ASPECT™300, switch ON the machine and wait till the power LED on front panel is steady green.
6. Perform the voltage tests detailed in **Test Table 7**. See **Figure 9** for Test Point locations.

Test table 7 – INPUT CONTROL BOARD - Voltage Tests

<i>Machine AC input voltage</i>	<i>Test Points</i>	<i>Expected reading</i>	<i>LEDs status and color</i>	<i>Note</i>
400Vac	Plug JB1 pin 1(+) to pin 9(-)	+15V/20kHz (oscilloscope needed)	LD5 ON green	Buck driver signal to the Buck IGBT on Buck/Boost board
230Vac	Plug JB1 pin 1(+) to pin 9(-)	+15 Vdc	LD5 ON green	Buck driver signal to the Buck IGBT on Buck/Boost board
400Vac or 230Vac	Plug JB1 pin 5(+) to pin 7&16(-)	400Vdc +/-1%	-	DC BUS feedback from Buck Boost Board
400Vac	Plug JB1 pin 8(+) to pin 7&16(-)	0 Vdc	LD4 OFF	Boost driver signal to the Boost IGBT on Buck/Boost board
230Vac	Plug JB1 pin 8(+) to pin 7&16(-)	+15V/20kHz (oscilloscope needed)	LD4 ON green	Boost driver signal to the Boost IGBT on Buck/Boost board
400Vac or 230Vac	Plug JB2 pin 3(+) to pin 1(-)	+24Vdc	-	Buck-Boost board Soft Start relay power supply
400Vac or 230Vac	Plug JC pin 1(+) to pin 2(-) & Plug J1 pin 12(+) to pin 6(-) & Plug JIP_S pin 6(+) to pin 2&4(-) & Plug JO pin 11(+) to pin 5(-)	+15Vdc	-	+15Vdc to supply the Control and Inverter boards generated by the Input Power board
400Vac or 230Vac	Plug JC pin 3(+) to pin 2(-)	24Vdc=Fan OFF 0Vdc=Fan ON	-	Enable FAN1 signal from Control Board
400Vac or 230Vac	Plug JC pin 4(+) to pin 2(-) & Plug J1 pin 10(+) to pin 6(-)	0 - 4Vdc (during welding)	-	Output current feedback to Control board from Output board 0-300A -> 0-4V
400Vac or 230Vac	Plug JC pin 5(+) to pin 2(-) & Plug JO pin 1(+) to Pin 5(-)	0 - 10Vdc (during welding or OCV)	-	Output voltage feedback to Control board from Output board 0-100V -> 0-10V
400Vac or 230Vac	Plug JC pin 7(+) to pin 2(-) & Plug J1 pin 1(+) to pin 6(-)	0Vdc=Inv ON 12Vdc=Inv OFF	-	Signal used to regulate OCV voltage or to switch OFF inverter
400Vac or 230Vac	Plug JC pin 9(+) to pin 2(-)	0Vdc or 5Vdc	-	Ready_OK signal - 5 Vdc = start-up sequence 0 Vdc = machine ready
400Vac or 230Vac	Plug JC pin 12(+) to pin 2(-) & Plug J1 pin 2(+) to pin 6(-)	0 - 6,4Vdc (during welding)	-	Output set current from Control board to Inverter board 0-320A -> 0-6,4V

INPUT CONTROL BOARD TEST (continued)

Test table 7 – INPUT CONTROL BOARD - Voltage Tests (continued)

<i>Machine AC input voltage</i>	<i>Test Points</i>	<i>Expected reading</i>	<i>LEDs status and color</i>	<i>Note</i>
400Vac or 230Vac	Plug JC pin 17(+) to pin 2(-)	24Vdc=G.Sol. OFF 0Vdc=G.Sol. ON	-	Enable gas solenoid signal from Control board
400Vac or 230Vac	Plug JC pin 18(+) to pin 2(-)	15Vdc=HF ON 0Vdc=HF OFF	-	Enable HF signal from Control board (15Vdc are present only for 3 seconds)
400Vac or 230Vac	Plug JC pin 21(+) to pin 2(-)	24Vdc=Fan OFF 0Vdc=Fan ON	-	Enable FAN signal from Control Board
400Vac or 230Vac	Plug JI pin 4(+) to pin 6(-) & Plug JO pin 3(+) to pin 5(-) & Plug JIP_S pin 3(+) to pin 4&2(-)	-15Vdc	-	-15Vdc to supply the Inverter and Output boards generated by the Input Power board
400Vac or 230Vac	Plug JO pin 8(+) to pin 5(-)	7 - 7,5 Vdc=LIFT TIG or VRD enabled 15Vdc=all other modes	-	Lift TIG and VRD Australian mode: output voltage signal to control board when Tig torch is not touching the work piece
400Vac or 230Vac	Plug JS pin 2(+) to pin 1(-)	+24Vdc = Solenoid ON	-	Gas Solenoid power supply when machine in TIG mode and trigger pressed
400Vac or 230Vac	Plug JF1 pin 4(+) to pin 1(-)	+24Vdc = Fan ON	-	Fan power supply
400Vac or 230Vac	Plug JF2 pin 4(+) to pin 1(-)	+24Vdc = Fan1 ON	-	Fan1 power supply
400Vac or 230Vac	Plug JF1 & JF2 pin 2(+) to pin 1(-)	1,5Vdc=low speed 5Vdc=high speed	-	Fan speed signal
400Vac	Plug JW pin 1 to pin 8	400Vac	-	Water cooler power supply when machine connected to 400Vac input line
230Vac	Plug JW pin 1 to pin 6	230Vac	-	Water cooler power supply when machine connected to 230Vac input line
400Vac or 230Vac	Plug JW pin 4(+) to pin 3(-)	+15Vdc with Coolarc disconnected 0Vdc with Coolarc connected	-	+15Vdc primary side generated by the Input Power board
400Vac or 230Vac	Plug JW pin 10(+) to pin 3(-)	0Vdc= water OK 9,5Vdc=water problem	-	Water flow sensor signal from Coolarc unit
400Vac or 230Vac	Plug JIP_P pin7&16(+) To pin 6&15(-)	+15Vdc	-	+15Vdc primary side generated by Input Power Board
400Vac or 230Vac	-	-	LD1 ON green	Microprocessor is flashed and is working
400Vac	-	-	LD2 ON green	All three phases power supply are present, when LD 2 is OFF single phase is detected
230Vac	-	-	LD2 flashing green	Indicates the machine is supplied at 230Vac
400Vac or 230Vac	-	-	LD3 OFF	LD3 blinking= overvoltage condition

Dip Switch bank - DS1 = For ASPECT 300 European Version all dip switches must be in OFF position

INVERTER BOARD RESISTANCE TEST

WARNING

Service and repair should be performed by only Lincoln Electric factory trained personnel. Unauthorized repairs performed on this equipment may result in danger to the technician or machine operator and will invalidate your factory warranty. For your safety and to avoid electrical shock, please observe all safety notes and precautions detailed throughout this manual. If for any reason you do not understand the test procedures or are unable to perform the test/repairs safely, contact your Local Lincoln Electric Service Department for electrical troubleshooting assistance before you proceed.

.....

TEST DESCRIPTION

This test will help determine if the “power section” of the inverter board are functioning correctly. This test will NOT indicate if the entire PC board is functional. This resistance test is preferable to a voltage test with the machine energized because this board can be damaged easily. In addition, it is dangerous to work on this board with the machine energized.

MATERIALS NEEDED

Volt/Ohmmeter
Schematic X1327

INVERTER BOARD RESISTANCE TEST (continued)

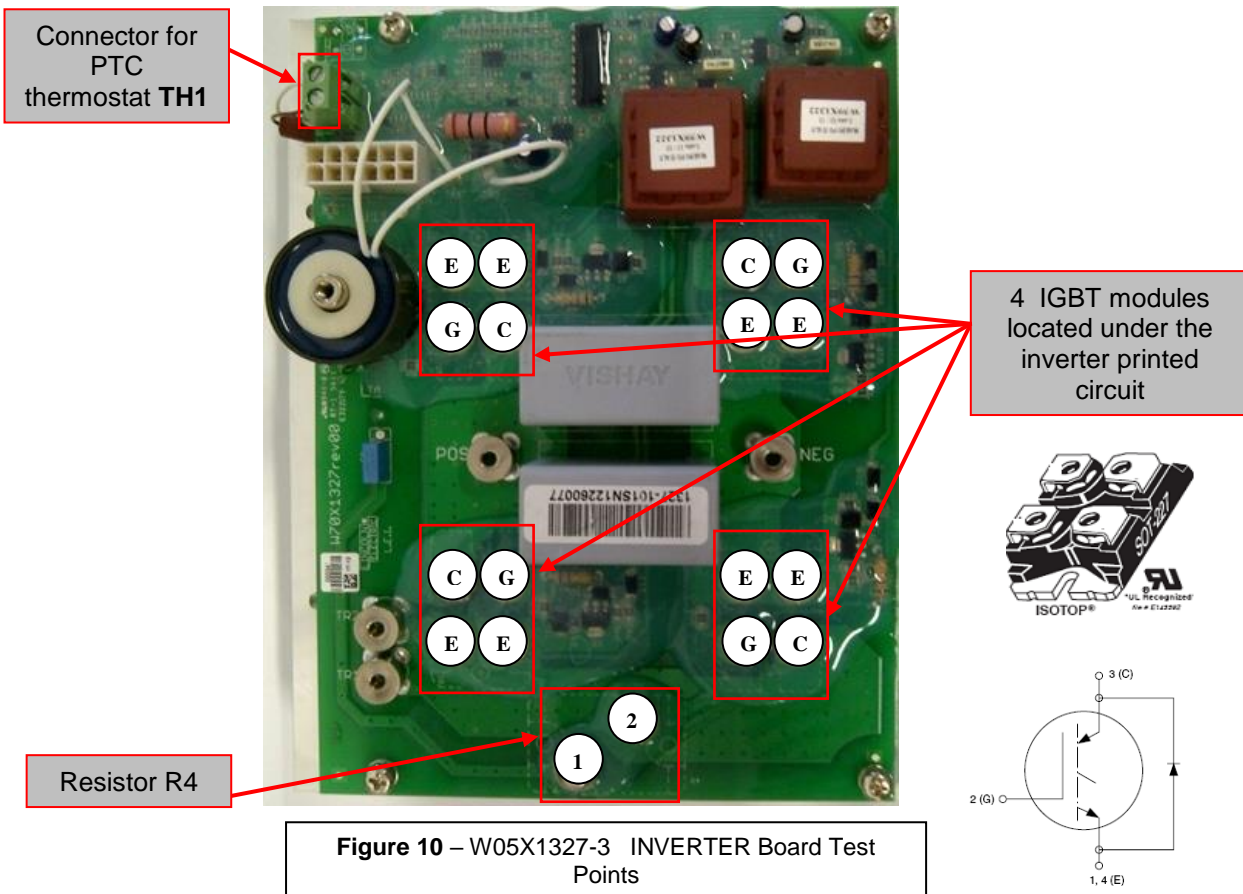

Figure 10 – W05X1327-3 INVERTER Board Test Points

TEST PROCEDURE

1. Remove main input power to the ASPECT™300
2. Perform the **Case removal** and **Discharge procedure**
3. Visually check for burned or damaged components. If any components are physically damaged the inverter board and damaged components should be replaced.
4. Check the PTC thermostat **TH1**, connected to the green connector (See **Figure 10** for Test Point locations.), with ohmmeter; correct value should be 53 ohms +/- 20% @ 25°C
5. Check the resistor **R4** between points 1&2 (See **Figure 10** for Test Point locations.), correct value should be 100 ohms +/-20%, when inverter is fully connected to the machine harnesses.
6. Check each IGBT module (**Q1,Q2,Q7,Q8**), with multimeter in diode test mode (See **Figure 10** for Test Point locations.), following the table below:

IGBT modules - table tests

Positive Probe (RED)	Negative Probe (BLACK)	Value
Emitter (E)	Collector (C)	0.3V - 0.7V Forward Diode Drop
Collector (C)	Emitter (E)	Open/Capacitor charge
Emitter (E)	Gate (G)	0.3V - 0.7V Forward Diode Drop

INVERTER BOARD VOLTAGE TEST

WARNING

Service and repair should be performed by only Lincoln Electric factory trained personnel. Unauthorized repairs performed on this equipment may result in danger to the technician or machine operator and will invalidate your factory warranty. For your safety and to avoid electrical shock, please observe all safety notes and precautions detailed throughout this manual. If for any reason you do not understand the test procedures or are unable to perform the test/repairs safely, contact your Local Lincoln Electric Service Department for electrical troubleshooting assistance before you proceed.

.....

TEST DESCRIPTION

This test will help to determine if the main inverter board is receiving the correct input voltages and if the correct regulated voltages are being processed and maintained by the inverter.

MATERIALS NEEDED

Volt/Ohmmeter
Schematic X1327

INVERTER BOARD VOLTAGE TEST (continued)

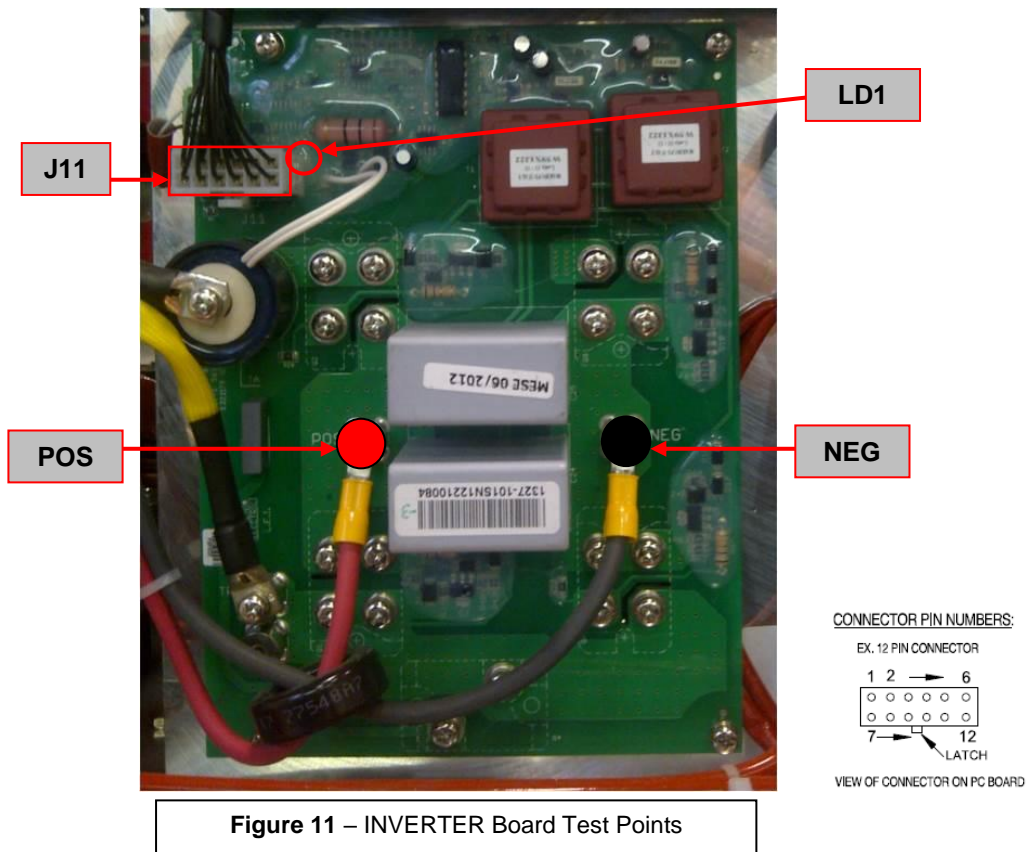

TEST PROCEDURE

⚠ Use always electrically insulate gloves during this test procedure

1. Carefully apply 400Vac +/- 15% or 230Vac-3ph +/-15% to the ASPECT™ 300
2. Turn the machine input switch to ON position, and wait till the power LED on front panel is steady green.
3. Perform the voltage tests detailed in **Test Table 8**. See **Figure 11** for Test Point locations:

Test table 8 – INVERTER BOARD - Voltage Tests

<i>Machine AC input voltage</i>	<i>Test Points</i>	<i>Expected reading</i>	<i>LEDs status and color</i>	<i>Note</i>
400Vac or 230Vac	POS(+) to NEG(-)	400Vdc	-	Vdc BUS from Buck/Boost board
400Vac or 230Vac	Plug J11 pin 1(+) to pin 6(-)	12Vdc = inverter OFF 0Vdc=inverter ON	-	Used to regulate OCVor to switch OFF inverter
400Vac or 230Vac	Plug J11 pin 2(+) to pin 6(-)	0 - 6,4Vdc (during welding)	-	Output set current from Control board 0-320A -> 0-6,4V
400Vac or 230Vac	Plug J11 pin 4(+) to pin 6(-)	-15Vdc	-	-15Vdc power supply generated by the input power board
400Vac or 230Vac	Plug J11 pin 11(+) to pin 6(-)	0 Vdc	-	Thermostat on the inverter heat sink signal If value close to 15Vdc = thermal condition
400Vac or 230Vac	Plug J11 pin 12(+) to pin 6(-)	+15Vdc	LD1 ON green	+15Vdc power supply generated by the input power board

OUTPUT BOARD TEST

WARNING

Service and repair should be performed by only Lincoln Electric factory trained personnel. Unauthorized repairs performed on this equipment may result in danger to the technician or machine operator and will invalidate your factory warranty. For your safety and to avoid electrical shock, please observe all safety notes and precautions detailed throughout this manual. If for any reason you do not understand the test procedures or are unable to perform the test/repairs safely, contact your Local Lincoln Electric Service Department for electrical troubleshooting assistance before you proceed.

.....

TEST DESCRIPTION

This test will help to determine if the output board is receiving the correct input signals and if the correct signals are being processed and applied to the IGBT board.

MATERIALS NEEDED

Volt/Ohmmeter
Schematic X1527

OUTPUT BOARD TEST (continued)

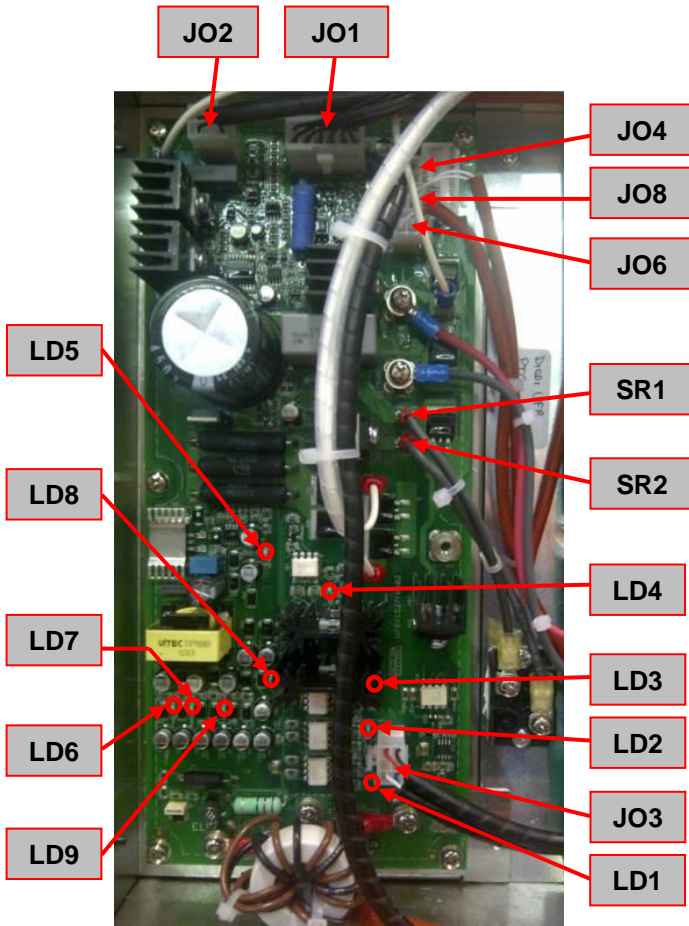

Figure 13 – W05X1527 OUTPUT Board Test Points

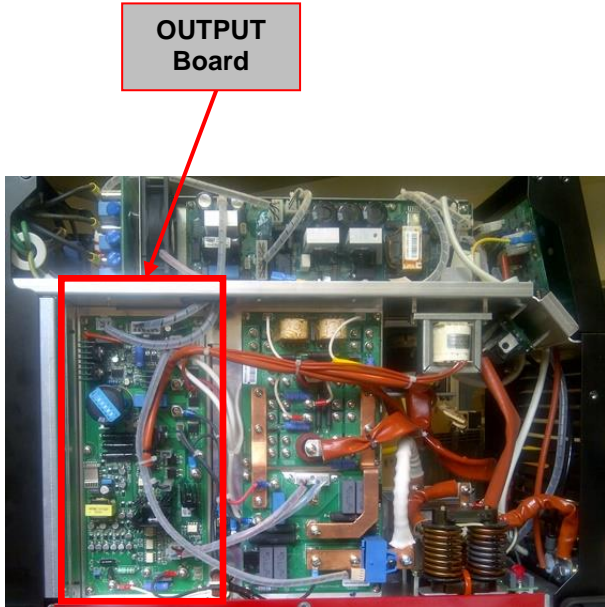
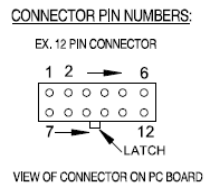

Figure 12 – OUTPUT board location



TEST PROCEDURE

- ⚠ Use always electrically insulate gloves during this test procedure
- 1. Remove main input power to the ASPECT™300
- 2. Perform the **Case removal** and **Discharge procedure**
- 3. Locate the Output board on the left side of the machine. See **Figure 12**.
- 4. Visually check for burned or damaged components. If any components are physically damaged the Output board should be replaced
- 5. Perform the tests detailed in **Test Table 9**. See **Figure 13** for Test Point locations:

Test table 9 – OUTPUT BOARD - Resistance Tests

Machine AC input voltage	Test Points	Expected reading	LEDs status and color	Note
Machine disconnected from input voltage and capacitors discharged	SR1 to SR2	50 Ohms +/-10%	-	Snubber Capacitor discharge resistor
Machine disconnected from input voltage and capacitors discharged	Plug JO3 pin 1 to pin 4	1,5 KOhms	-	Gate-Emitter Output IGBT module NEGATIVE
Machine disconnected from input voltage and capacitors discharged	Plug JO3 pin 3 to pin 6	1,5 KOhms	-	Gate-Emitter Output IGBT module POSITIVE
Machine disconnected from input voltage and capacitors discharged	Plug JO6 pin 1 to pin 2	50 - 60 Ohms +/-10% @ 20°C	-	Output IGBT thermal sensor (PTC)
Machine disconnected from input voltage and capacitors discharged	Plug JO8 pin 1 to pin 2	40 - 50 Ohms +/- 10% @ 20°C	-	Output diodes thermal sensor (PTC)

OUTPUT BOARD TEST (continued)

6. Carefully apply 400Vac +/- 15% or 230Vac-3ph +/-15% to the ASPECT™300
7. Turn the machine input switch to ON position, and wait till the power LED on front panel is steady green.
8. Perform the tests detailed in **Test Table 10**. See **Figure 13** for Test Point locations:

Test table 10 – OUTPUT BOARD - Tests

<i>Machine AC input voltage</i>	<i>Test Points</i>	<i>Expected reading</i>	<i>LEDs status and color</i>	<i>Note</i>
400Vac or 230Vac	Plug JO1 pin 1(+) to pin 5(-)	0 - 10Vdc (during welding or OCV)	-	Output voltage feedback to Control board 0-100V -> 0-10V
400Vac or 230Vac	Plug JO1 pin 3(+) to pin 5(-)	-15Vdc	-	-15Vdc power supply generated by the input power board
400Vac or 230Vac	Plug JO1 pin 4(+) to pin 5(-)	0 - 4Vdc (during welding)	-	Output current feedback to Control board from Output board 0-300A -> 0-4V
400Vac or 230Vac	Plug JO1 pin 8(+) to pin 5(-)	7,0 - 7,5 Vdc=LIFT TIG or VRD enabled 15Vdc=all other modes	-	Lift TIG and VRD Australian mode: output voltage signal to control board when Tig torch is not touching the work piece
400Vac or 230Vac	Plug JO1 pin 10(+) to pin 5(-)	5Vdc=OK 0Vdc=thermal error	-	Output thermal error
400Vac or 230Vac	Plug JO1 pin 11(+) to pin 5(-)	+15Vdc	-	+15Vdc power supply generated by the input power board
400Vac or 230Vac	Plug JO2 pin 3&6(+) to pin 1&4(-)	+75Vdc	-	+75Vdc power supply generated by the input power board
400Vac or 230Vac TIG DC, Electrode Negative mode	Plug JO3 pin 1(+) to pin 4(-)	+15Vdc	LD2 ON red	Gate signal to NEGATIVE output IGBT module
400Vac or 230Vac TIG DC, Electrode Positive mode or Stick mode	Plug JO3 pin 3(+) to pin 6(-)	+15Vdc	LD1 ON red	Gate signal to POSITIVE output IGBT module
400Vac or 230Vac	Plug JO4 pin 1(+) to pin 4(-)	+15Vdc	-	+15Vdc for Current Sensor
400Vac or 230Vac	Plug JO4 pin 2(+) to pin 4(-)	-15Vdc	-	-15Vdc for Current Sensor
400Vac or 230Vac	Plug JO4 pin 3(+) to pin 4(-)	0 – 4 Vdc (during welding)	-	Output current feedback from current sensor 0-300A -> 0-4V
400Vac or 230Vac	-	-	LD3 red	Positive background. Example: DC LIFT TIG and Stick DC modes
400Vac or 230Vac	-	-	LD4 red	Negative background. Example: DC TIG HF (with trigger pressed)
400Vac or 230Vac	Plug JO1 pin 6(+) to pin 5 (-)	0V = OK 5Vdc = Error snubber circuit		
400Vac or 230Vac	-	Always in any welding modes and condition	LD5 ON green	+15V background circuit present
400Vac or 230Vac	-	Always in any welding modes and condition	LD6 ON green	AC POSITIVE switch driver power supply
400Vac or 230Vac	-	Always in any welding modes and condition	LD7 ON green	AC NEGATIVE switch driver power supply
400Vac or 230Vac	-	Always in any welding modes and condition	LD8 ON green	Background POSITIVE switch driver power supply
400Vac or 230Vac	-	Always in any welding modes and condition	LD9 ON green	Background NEGATIVE switch driver power supply

OUTPUT DIODE BOARD RESISTANCE TEST

WARNING

Service and repair should be performed by only Lincoln Electric factory trained personnel. Unauthorized repairs performed on this equipment may result in danger to the technician or machine operator and will invalidate your factory warranty. For your safety and to avoid electrical shock, please observe all safety notes and precautions detailed throughout this manual. If for any reason you do not understand the test procedures or are unable to perform the test/repairs safely, contact your Local Lincoln Electric Service Department for electrical troubleshooting assistance before you proceed.

.....

TEST DESCRIPTION

This test will help determine if the “power section” of the output diode board are functioning correctly. This test will NOT indicate if the entire PC board is functional but will give you the first feedback regarding the status of the output power components.

MATERIALS NEEDED

Volt/Ohmmeter
Schematic X1523

OUTPUT DIODE BOARD RESISTANCE TEST (continued)

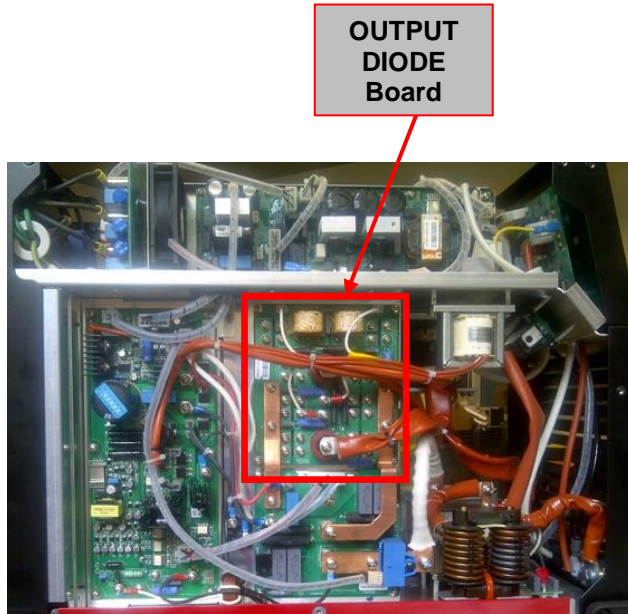

Figure 14 – W05X1523 OUTPUT DIODE board location

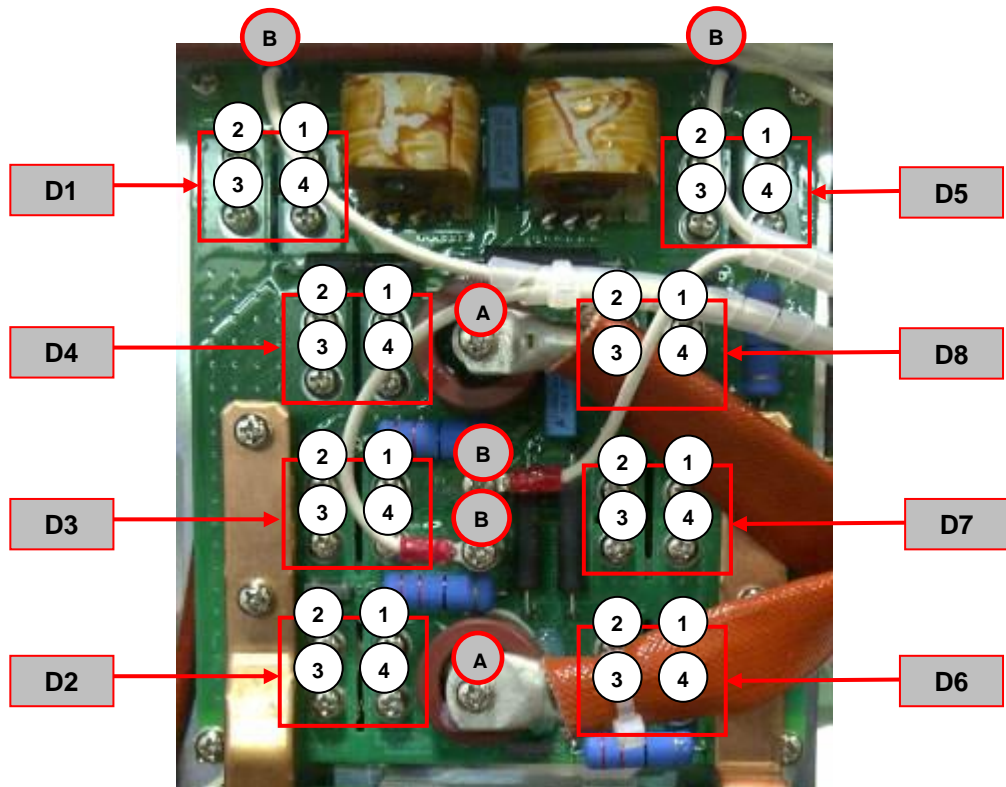
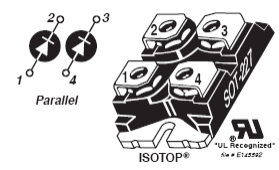

Figure 15 – W05X1523 OUTPUT DIODE board test points



OUTPUT DIODE BOARD RESISTANCE TEST (continued)

TEST PROCEDURE

⚠ **Use always electrically insulate gloves during this test procedure**

1. Remove main input power to the ASPECT™300
2. Perform the **Case removal** and **Discharge procedure**
3. Locate the Output Diode board on the left side of the machine. See **Figure 14**.
4. Visually check for burned or damaged components. If any components are physically damaged the Output Diode board and /or diode modules should be replaced
5. Disconnect the two transformer cables (**A**) and the four auxiliary windings cables (**B**). Mark their position before removing them.
6. Follow the **Test table 11** to perform the Diode modules tests. See **Figure 15** for Test Point locations. NOTE: If a short circuit is detected during this test, to determinate which is the diode module defected is necessary to remove the Output Diode board and check one by one the diode modules alone. See Output Diode board disassembly procedure available inside this manual.

Test table 11 - Output Diode modules test

Positive Probe (RED)	Negative Probe (BLACK)	Value
4 (anode)	3 (cathode)	0.3V - 0.7V Forward Diode Drop
3 (cathode)	4 (anode)	OPEN
1 (anode)	2 (cathode)	0.3V - 0.7V Forward Diode Drop
2 (cathode)	1 (anode)	OPEN

IGBT BOARD RESISTANCE TEST

WARNING

Service and repair should be performed by only Lincoln Electric factory trained personnel. Unauthorized repairs performed on this equipment may result in danger to the technician or machine operator and will invalidate your factory warranty. For your safety and to avoid electrical shock, please observe all safety notes and precautions detailed throughout this manual. If for any reason you do not understand the test procedures or are unable to perform the test/repairs safely, contact your Local Lincoln Electric Service Department for electrical troubleshooting assistance before you proceed.

.....

TEST DESCRIPTION

This test will help determine if the “power section” of the IGBT board are functioning correctly. This test will NOT indicate if the entire PC board is functional but will give you the first feedback regarding the status of the output power components.

MATERIALS NEEDED

Volt/Ohmmeter
Schematic X1524

IGBT BOARD RESISTANCE TEST (continued)

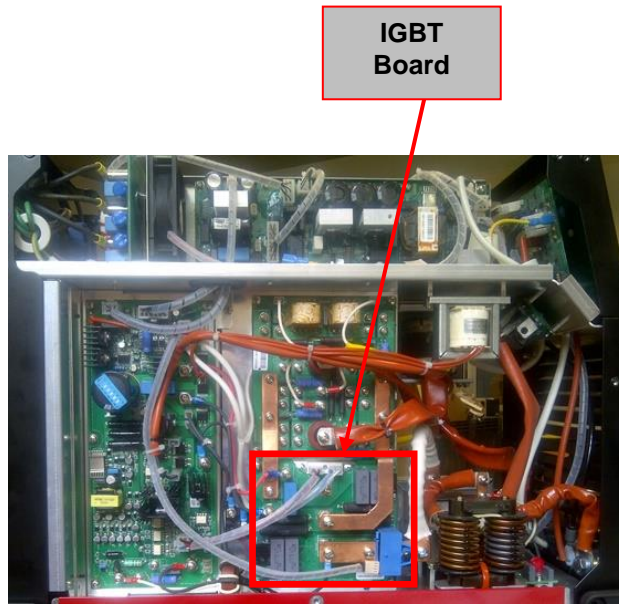

Figure 16 – W05X1524 IGBT board location

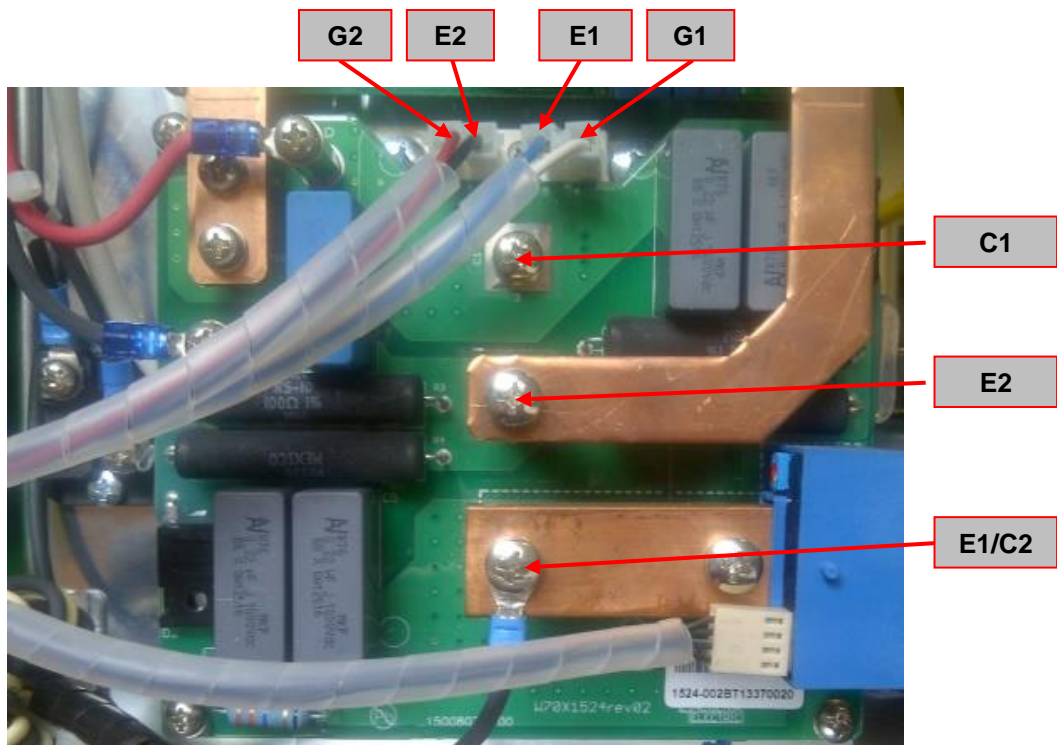

Figure 17 – W05X1524 IGBT board test points

IGBT BOARD RESISTANCE TEST (continued)

TEST PROCEDURE

⚠ Use always electrically insulate gloves during this test procedure

1. Remove main input power to the ASPECT™300
2. Perform the **Case removal** and **Discharge procedure**
3. Locate the IGBT board on the left side of the machine. See **Figure 16**.
4. Visually check for burned or damaged components. If any components are physically damaged the IGBT board and /or IGBT module should be replaced
5. Disconnect the cables **E1, G1, E2, G2**. Mark their position before removing them.
6. Follow the **Test table 12** to perform the IGBT board tests. See **Figure 17** for Test Point locations.

Test table 12 – IGBT board test

Positive Probe (RED)	Negative Probe (BLACK)	Value
E2	G2	OPEN
C2	E2	OPEN
E2	C2	0,3 - 0,7 V
E1	G1	OPEN
C1	E1	OPEN
E1	C1	0,3 - 0,7 V

HF BOARD TEST

WARNING

Service and repair should be performed by only Lincoln Electric factory trained personnel. Unauthorized repairs performed on this equipment may result in danger to the technician or machine operator and will invalidate your factory warranty. For your safety and to avoid electrical shock, please observe all safety notes and precautions detailed throughout this manual. If for any reason you do not understand the test procedures or are unable to perform the test/repairs safely, contact your Local Lincoln Electric Service Department for electrical troubleshooting assistance before you proceed.

.....

TEST DESCRIPTION

This test will help to determine if the HF (High Frequency) board (w05X1615) is faulty.

MATERIALS NEEDED

Volt/Ohmmeter
Oscilloscope
Schematic X1615

HF BOARD TEST (continued)



Figure 18 – W05X1615 HF board location

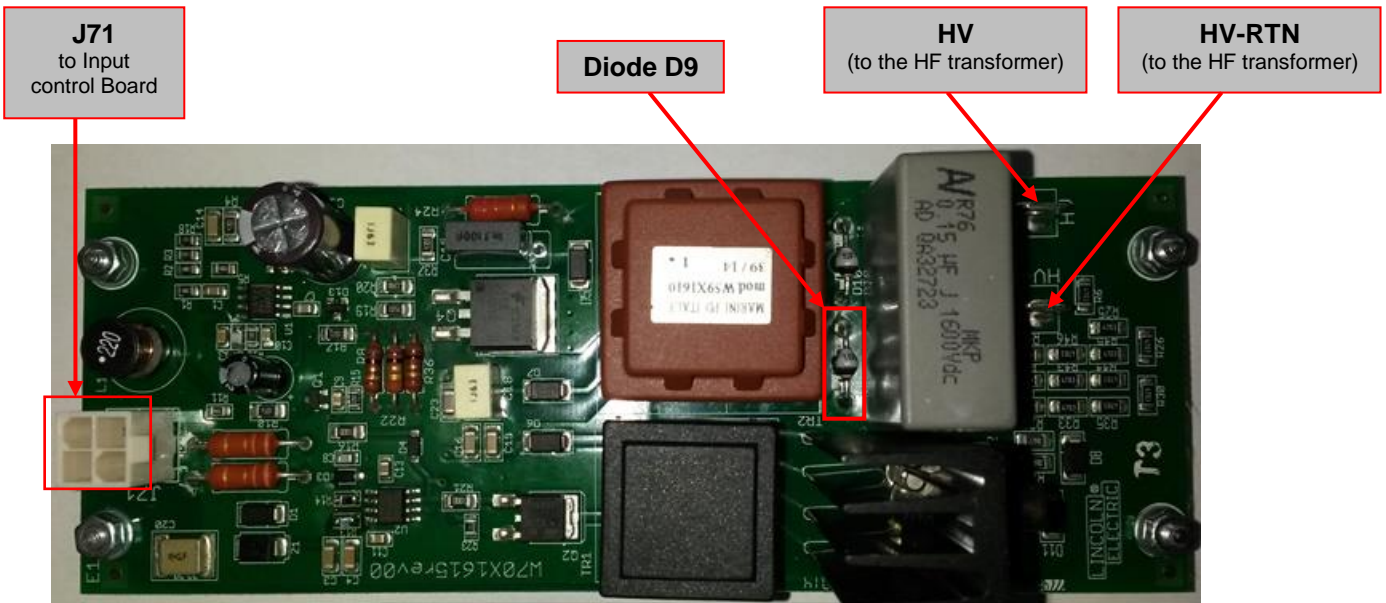
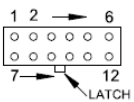

Figure 19 – W05X1615 HF board test points

CONNECTOR PIN NUMBERS:

EX. 12 PIN CONNECTOR



VIEW OF CONNECTOR ON PC BOARD

HF BOARD TEST (continued)

TEST PROCEDURE

⚠ Use always electrically insulate gloves during this test procedure

1. Carefully apply 400Vac +/- 15% or 230Vac-3ph +/-15% to the ASPECT™300
2. Turn the machine input switch to ON position and wait till the power LED on front panel is steady green.
3. Set the machine to TIG DC or AC HF welding mode and connect the TIG torch to the machine.
4. Check between **J71** pin 2 & pin 4 for 24Vdc always present
5. Check between **HV-RTN** and **cathode of diode D10** for 1000V +/- 40V
6. Press the trigger and check between **J71** pin 3 & pin 4 for 15Vdc (only for 3 seconds)
7. When 15Vdc are present between **J71** pin 3 & pin 4 check waveform, as indicated on the figure below, between cathode and anode of **D12**. NOTE: HV and HV-RTN have to be connected to the HF transformer during this test.

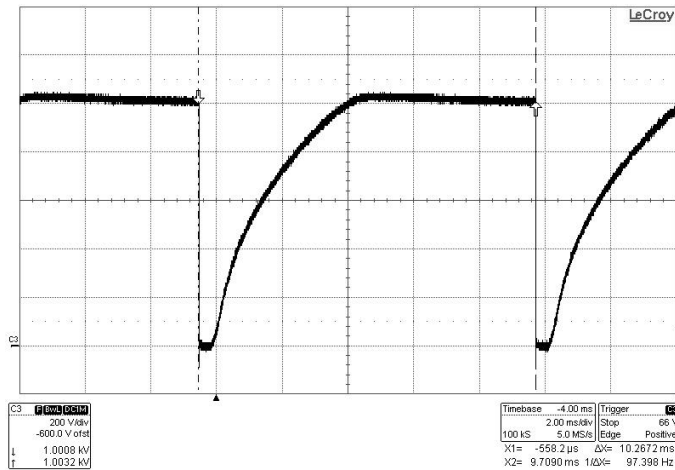

CONTROL BOARD AND USER INTERFACE TEST

WARNING

Service and repair should be performed by only Lincoln Electric factory trained personnel. Unauthorized repairs performed on this equipment may result in danger to the technician or machine operator and will invalidate your factory warranty. For your safety and to avoid electrical shock, please observe all safety notes and precautions detailed throughout this manual. If for any reason you do not understand the test procedures or are unable to perform the test/repairs safely, contact your Local Lincoln Electric Service Department for electrical troubleshooting assistance before you proceed.

.....

TEST DESCRIPTION

The control board and UI are not easy to be checked, as it works mainly with software; this section will help, as best as possible, to determine if the control board or the User Interface are faulty and how to interpret error codes.

MATERIALS NEEDED

Volt/Ohmmeter
Schematic X1648 (Control Board_ CODE 52125)
Schematic X1649 (UI Board_ CODE 52125)
Schematic X1705 (Control Board_ CODE 50595)
Schematic X1642 (UI Board_ CODE 50595)

Calibration must be done if the control board is replaced!

CONTROL BOARD AND USER INTERFACE TEST (continued)

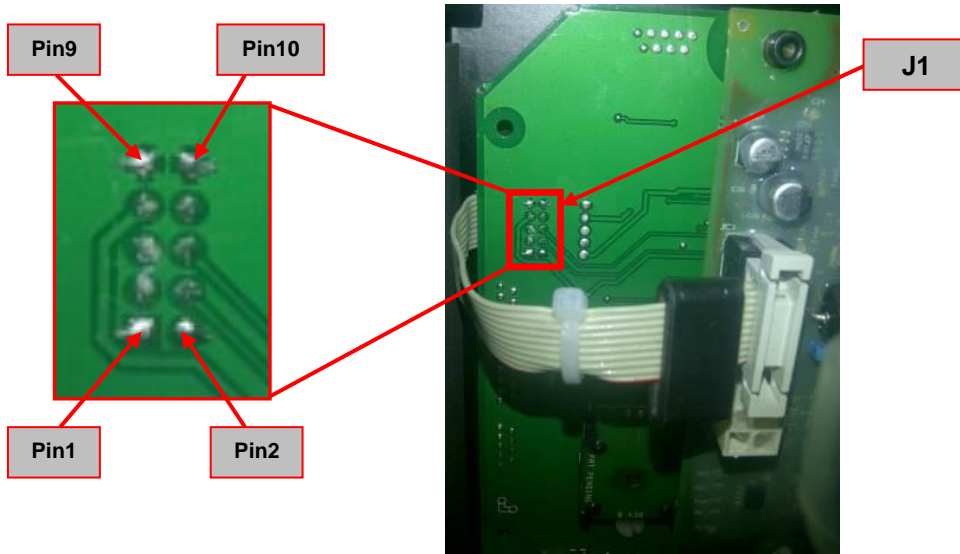

Figure 22 – W05X1649 User Interface boards test points

TEST PROCEDURE

⚠ Use always electrically insulate gloves during this test procedure

1. Remove main input power to the ASPECT™300.
2. Perform the **Case Removal** and **Discharge procedure**
3. Locate the Control and UI boards on the upper side of the machine front panel. See **Figure 20**.
4. Visually check for burned or damaged components. If any components are physically damaged the Control or UI board should be replaced
5. Carefully apply 400Vac/3ph +/-15% or 230Vac-3ph +/-15% via the input cable to the ASPECT™300 and switch ON the machine and wait till the power LED on front panel is steady green.
6. Perform the voltage tests detailed in **Test Table 13**. See **Figure 21** and **Figure 22** for Test Point locations.

Test table 13 – CONTROL AND UI BOARD - Tests

Machine AC input voltage	Test Points	Expected reading	LEDs status and color	Note
400Vac or 230Vac	Plug JC1 pin 1(+) to pin 2(-)	+15Vdc	LD2 ON green	+15Vdc to supply the Control boards generated by the Input Power board
400Vac or 230Vac	-	+5Vdc	LD1 ON green	+5Vdc generated by the Control Board
400Vac or 230Vac	-	-15Vdc	LD3 ON green	-15Vdc generated by the Control Board
400Vac or 230Vac	Plug JC1 pin 3(+) to pin 2(-)	24Vdc=Fan OFF 0Vdc=Fan ON	-	Enable FAN1 signal from Control Board
400Vac or 230Vac	Plug JC1 pin 4(+) to pin 2(-)	0 - 4Vdc	-	Output current feedback to Control board from Output board 0-300A -> 0-4V
400Vac or 230Vac	Plug JC1 pin 5(+) to pin 2(-)	0 - 10Vdc	-	Output voltage feedback to Control board from Output board 0-100V -> 0-10V
400Vac or 230Vac	Plug JC1 pin 7(+) to pin 2(-)	0Vdc=Inv ON 12Vdc=Inv OFF	-	Signal used to regulate OCV voltage or to switch OFF inverter
400Vac or 230Vac	Plug JC1 pin 9(+) to pin 2(-)	0Vdc or 5Vdc	-	Ready_OK signal - 5 Vdc = start-up sequence 0 Vdc = machine ready
400Vac or	Plug JC1 pin 12(+) to	0 - 6,4V	-	Output set current from Control board to

230Vac	pin 2(-)			Inverter board 0-320A -> 0-6,4V
400Vac or 230Vac	Plug JC1 pin 17(+) to pin 2(-)	24Vdc=G.Sol. OFF 0Vdc=G.Sol. ON	-	Enable gas solenoid signal from Control board
400Vac or 230Vac	Plug JC1 pin 18(+) to pin 2(-)	15Vdc=HF ON 0Vdc=HF OFF	-	Enable HF signal from Control board
400Vac or 230Vac	Plug JC1 pin 21(+) to pin 2(-)	24Vdc=Fan OFF 0Vdc=Fan ON	-	Enable FAN signal from Control Board
400Vac or 230Vac	Plug JC4 pin 4(+) to pin 1(-)	+15Vdc	-	+15Vdc insulated from the SGND, generated by the Control board; power supply for the remote circuit.
400Vac or 230Vac	Plug JC5 pin 2(+) to pin 1(-)	15Vdc=trigger not pushed 0Vdc= trigger pushed	-	Trigger signal
400Vac or 230Vac	Plug J1 pin 1&2(+) to pin 9&10(-)	+15Vdc	-	+15Vdc to supply the UI boards generated by the Input Power board
400Vac or 230Vac	Plug J1 pin 7&8(+) to pin 9&10(-)	+5Vdc	-	+5Vdc generated by the Control Board

Dip Switch bank "SW1":

For ASPECT™ 300 **CE version** all dip switches must be OFF.

For ASPECT™ 300 **Austalia version** dip switch 1=ON 2,3,4=OFF



GAS SOLENOID TEST

WARNING

Service and repair should be performed by only Lincoln Electric factory trained personnel. Unauthorized repairs performed on this equipment may result in danger to the technician or machine operator and will invalidate your factory warranty. For your safety and to avoid electrical shock, please observe all safety notes and precautions detailed throughout this manual. If for any reason you do not understand the test procedures or are unable to perform the test/repairs safely, contact your Local Lincoln Electric Service Department for electrical troubleshooting assistance before you proceed.

.....

TEST DESCRIPTION

This test will aid the technician to determine if the Gas solenoid is receiving the correct input voltage and if the solenoid is good

MATERIALS NEEDED

Volt/Ohmmeter
Machine Schematic

GAS SOLENOID TEST (continued)

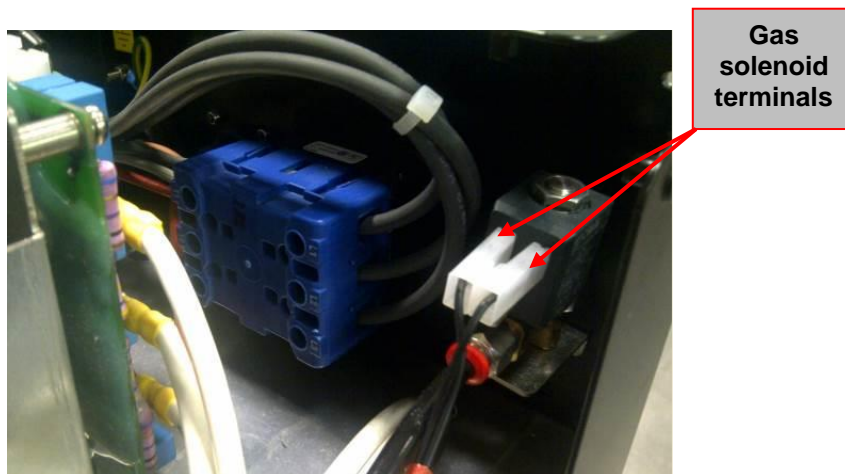

TEST PROCEDURE

⚠ Use always electrically insulate gloves during this test procedure

1. Carefully apply 400Vac +/- 15% or 230Vac-3ph +/-15% to the ASPECT™300
2. Turn the machine input switch to ON position, and wait till the power LED on front panel is steady green.
3. Set the machine to TIG DC or AC HF welding mode and connect the TIG torch to the machine.
4. Located the Gas solenoid on the internal upper right side of the rear panel, see picture above.
5. Push the trigger and with voltmeter check for +24Vdc between Gas solenoid terminals.
6. If voltage supply is not present the Input Control board is not sending the correct activation voltage. May be a problem can be present on the Input Control board or on the Control board, perform the Input control board and Control board tests.
7. If the voltage supply is present at the Gas solenoid terminals, check the solenoid resistance.
8. Remove the two leads from the Gas solenoid and check the Gas solenoid coil resistance. Normal coil resistance is 55 Ohms +/-10%
9. If the coil resistance is very high or very low the Gas solenoid may be faulty, replace.

DISASSEMBLY OPERATIONS

EMC FILTER BOARD REMOVAL AND REPLACEMENT PROCEDURE

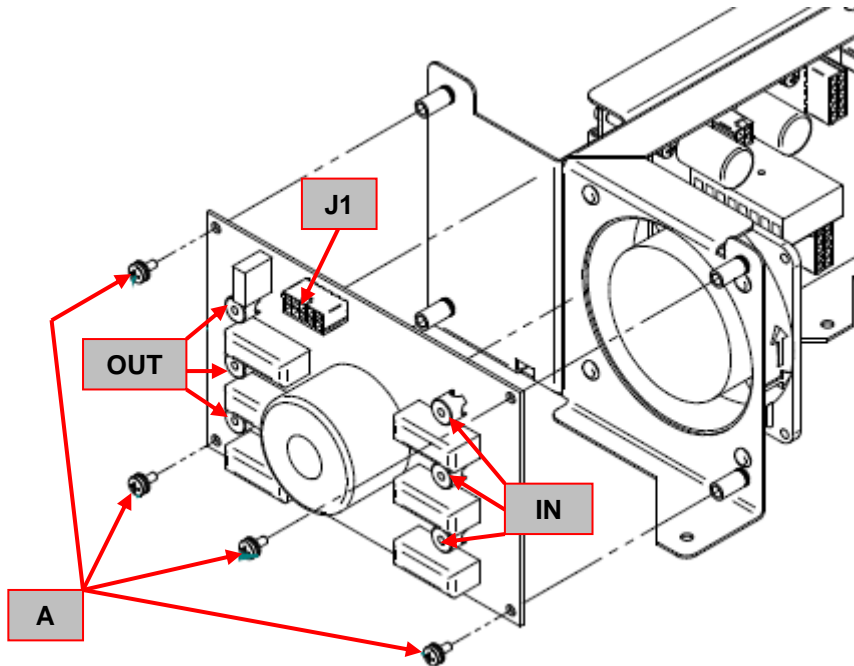
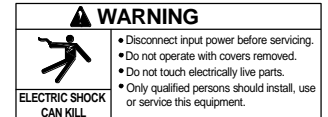

Figure 23

REMOVAL PROCEDURE

Necessary tool:

- A short Phillips screwdriver PH02

1. Remove main input power to the ASPECT™300.
2. Perform the **Case Removal and Discharge procedure**
3. Locate the EMC board W05X1471. See **Figure 23**
4. Disconnect the connectors **J1**. See **Figure 23**
5. Using a short Phillips screwdriver PH02 remove the 3 input cables “IN” and the 3 Output cables “OUT” from the EMC board. See **Figure 23**
6. Using a short Phillips screwdriver PH02 remove the 4 screws (**A**) that fix the EMC board to the machine frame. See **Figure 23**.
7. Remove the EMC board from the machine.
8. **For the new Input Board re-assembly operations**, make the previous steps in the reverse order

!! During performing the following steps take note of the size and type of screws being removed and associated washers. Upon reassembly the same type and size screw and washers **MUST** be used.

DISASSEMBLY OPERATIONS

3 PHASES INPUT RECTIFIER BRIDGE REMOVAL AND REPLACEMENT PROCEDURE

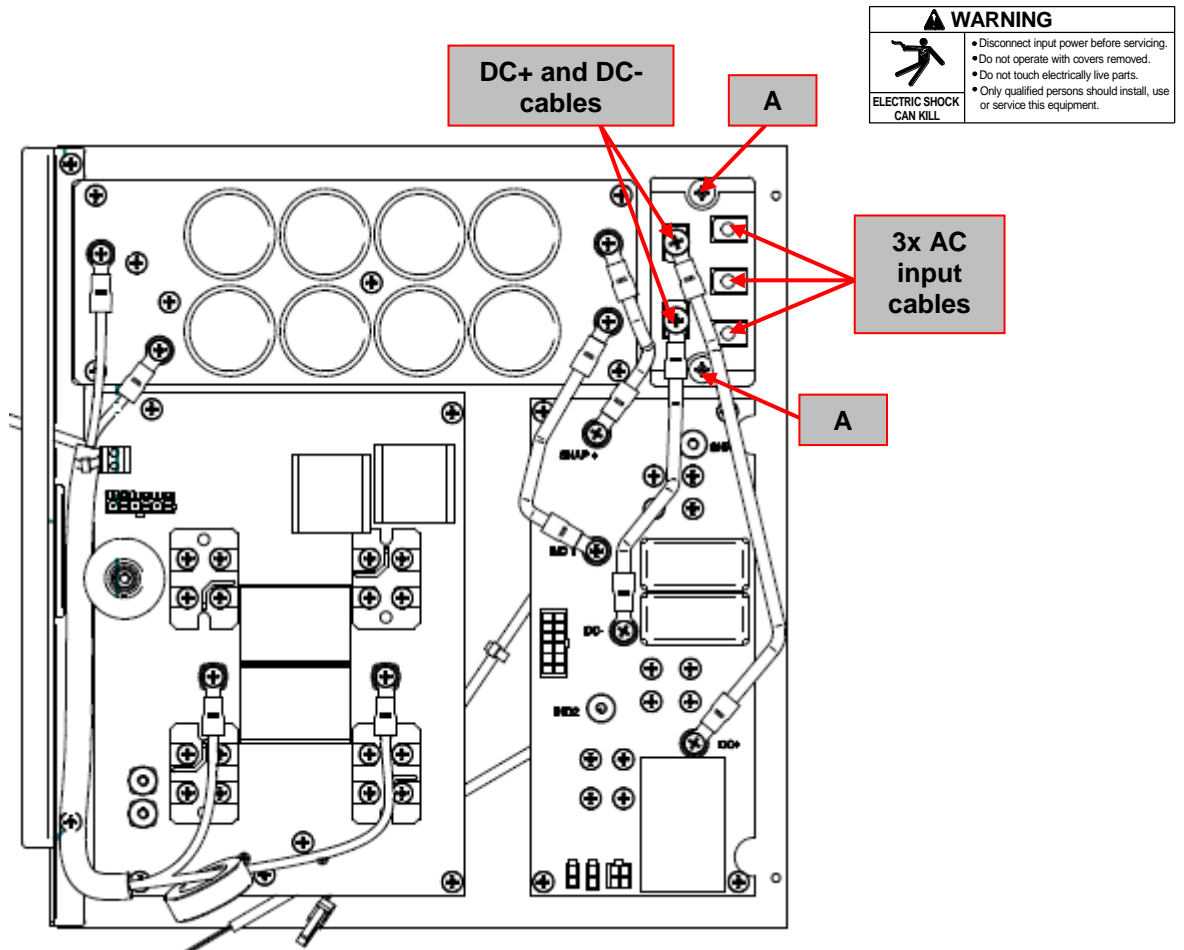

Figure 24

REMOVAL PROCEDURE

Necessary tools:

- Phillips screwdriver PH02
- Dow Corning 340 Heat Sink Compound
- Torque wrench

1. Remove main input power to the ASPECT™300.
2. Perform the **Case Removal** and **Discharge procedure**
3. Locate the 3 phases input rectifier bridge W6814030 on the right side of the machine. See **Figure24**
4. Using a Phillips screwdriver PH02 remove the 3 AC input cables and the 2 output DC+ and DC- cables from the 3 phases input rectifier bridge. See **Figure 24**
5. Using a Phillips screwdriver PH02 remove the 2 screws (**A**) that fix the 3 phases input rectifier bridge to the heat sink. See **Figure 24**
6. Remove the 3 phases input rectifier bridge from the machine.

!! During performing the following steps take note of the size and type of screws being removed and associated washers. Upon reassembly the same type and size screw and washers **MUST** be used.

REASSEMBLY PROCEDURE

1. Clean the heat sink mounting surface from the old thermal compound.
2. Apply a thin layer of new thermal compound to the mating surfaces (Dow Corning 340)
3. Assemble the new 3 phases input rectifier bridge to the heat sink using the 2 screws (**A**) previously removed (torque 1,5Nm max.)
4. Assemble the 3 AC input cables and the 2 output cables DC+ and DC- previously removed (torque 1,5Nm max.)

DO NOT USE CORDLESS SCREWDRIVERS FOR THE POWER MODULES!



DISASSEMBLY OPERATIONS

BUCK/BOOST BOARD REMOVAL AND REPLACEMENT PROCEDURE

WARNING	
	<ul style="list-style-type: none">• Disconnect input power before servicing.• Do not operate with covers removed.• Do not touch electrically live parts.• Only qualified persons should install, use or service this equipment.

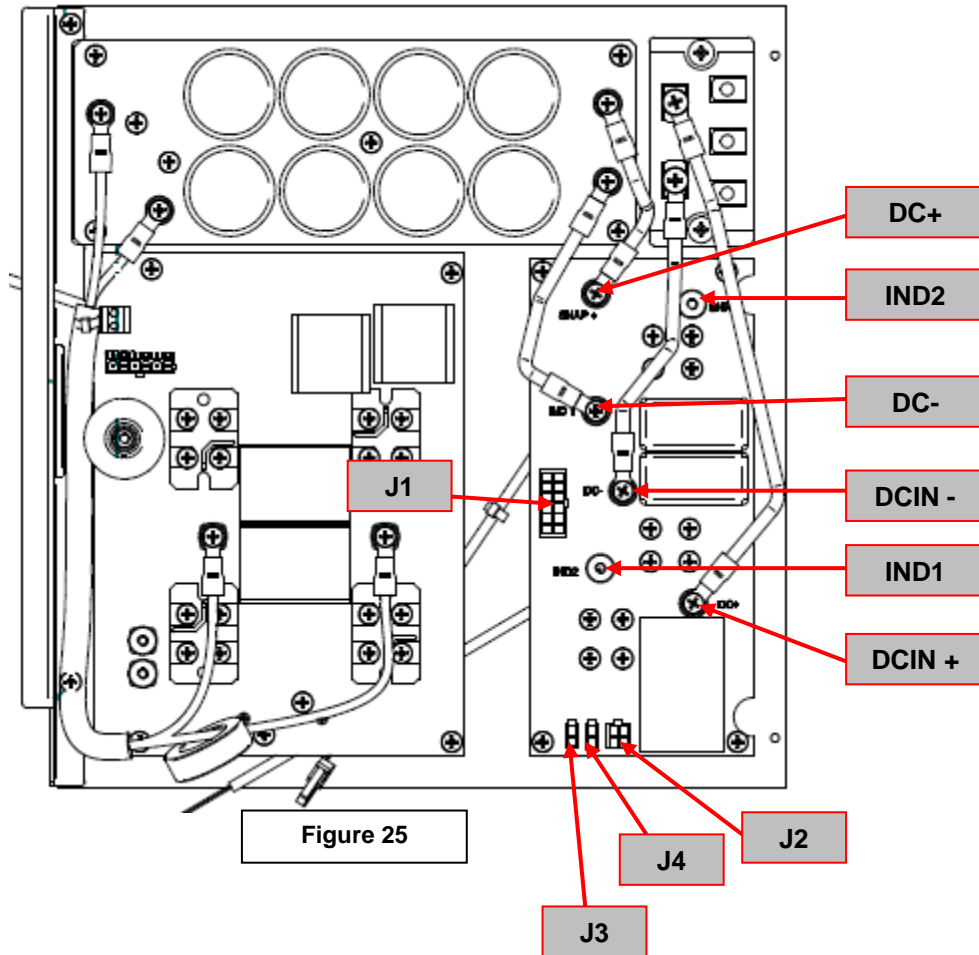

REMOVAL PROCEDURE

Necessary tools:

- Phillips screwdriver PH02
- Dow Corning 340 Heat Sink Compound
- Torque wrench
- Silicon sealer

!! During performing the following steps take note of the size and type of screws being removed and associated washers. Upon reassembly the same type and size screw and washers **MUST** be used.

1. Remove main input power to the ASPECT™300
2. Perform the **Case Removal and Discharge procedure**
3. Locate the Buck/Boost board W05X0982 on the right side of the machine, see **Figure 25**
4. Remove connectors **J1**, **J2**, **J3** and **J4** from the Buck/Boost board. Label **J3** and **J4** for reassembly step. See **Figure 25**
5. Using the Phillips screwdriver remove the cables from terminal **DCIN+**, **DCIN-**, **DC+** and **DC-**. Label them before disconnecting. See **Figure 25**
6. Using the Phillips screwdriver remove the cables from terminal **IND1** and **IND2**. Label them before disconnecting. See **Figure 25**

DISASSEMBLY OPERATIONS

BUCK/BOOST BOARD REMOVAL AND REPLACEMENT PROCEDURE (continued)

 <p>WARNING</p>	<ul style="list-style-type: none"> • Disconnect input power before servicing. • Do not operate with covers removed. • Do not touch electrically live parts. • Only qualified persons should install, use or service this equipment.
<p>ELECTRIC SHOCK CAN KILL</p>	

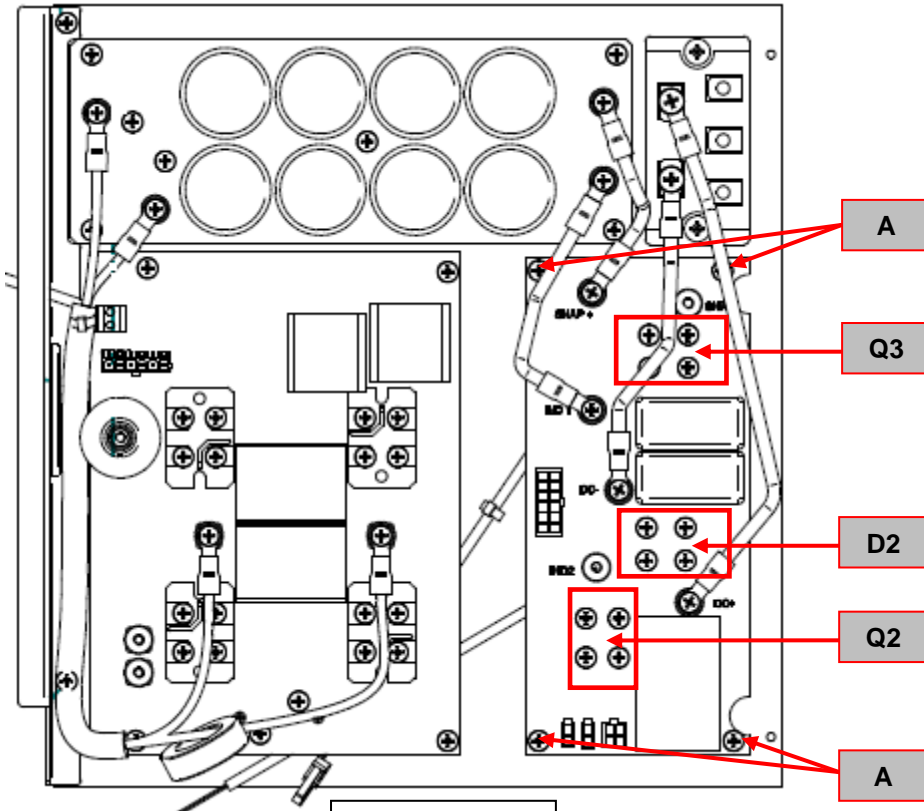

Figure 26

- Using the Phillips screwdriver remove the four screws from the module **D2**. Carefully remove the silicon sealant to access the screws if present. See **Figure 26**
- Using the Phillips screwdriver remove the four screws from the module **Q3**. Carefully remove the silicon sealant to access the screws if present. See **Figure 26**
- Using the Phillips screwdriver remove the four screws from the module **Q2**. Carefully remove the silicon sealant to access the screws if present. See **Figure 26**
- Locate the 4 corner screws (**A**) and using the phillips screwdriver remove them. See **Figure 26**
- Carefully remove the Buck/Boost board.
- Note the position and type of the module **Q3**, **Q2** and **D2**. See **Figure 26**
- Carefully remove the two screws from the module(s) to be replaced and remove the module(s) from the heat sink.

REASSEMBLY PROCEDURE

- Clean the heat sink mounting surfaces from the old thermal compound.
- Apply a thin layer of new thermal compound to the new module(s) mating surface (Dow Corning 340)
- Carefully assemble the new module(s) to the heat sink in the correct position using the two screws previously removed (torque 1,5Nm max.). Be carefully about component type and polarity. One end of the module has an hole and the other end has a "U", new module(s) must be mounted in the same configuration
- Install the new Buck/Boost board using the four screws (**A**) previously removed from the board corners.
Attention!: Do not tighten these screws yet.
- Mount the 4 screws previously removed from module **D2** (torque 0,8Nm max.). Seal screw heads with silicon. Do the same for module **Q3** and **Q2**.
- Finish tightening the 4 Buck/Boost board corner screws (torque 1,5Nm max.).
- Using the screws previously removed reconnect the leads **DCIN+**, **DCIN-**, **DC+**, **DC-**, **IND1** and **IND2** (torque 1,5Nm max.).
- Reconnect connectors **J1**, **J2**, **J3** and **J4** to the Buck/Boost board
- Replace cable tie where necessary

PAY ATTENTION! of how to position the open end mounting of modules to heat-sink.



See printed circuit board for reference

DO NOT USE CORDLESS SCREWDRIVERS FOR THE POWER MODULES!



DISASSEMBLY OPERATIONS

CAPS BOARD REMOVAL AND REPLACEMENT PROCEDURE

⚠ WARNING	
	<ul style="list-style-type: none">• Disconnect input power before servicing.• Do not operate with covers removed.• Do not touch electrically live parts.• Only qualified persons should install, use or service this equipment.
ELECTRIC SHOCK CAN KILL	

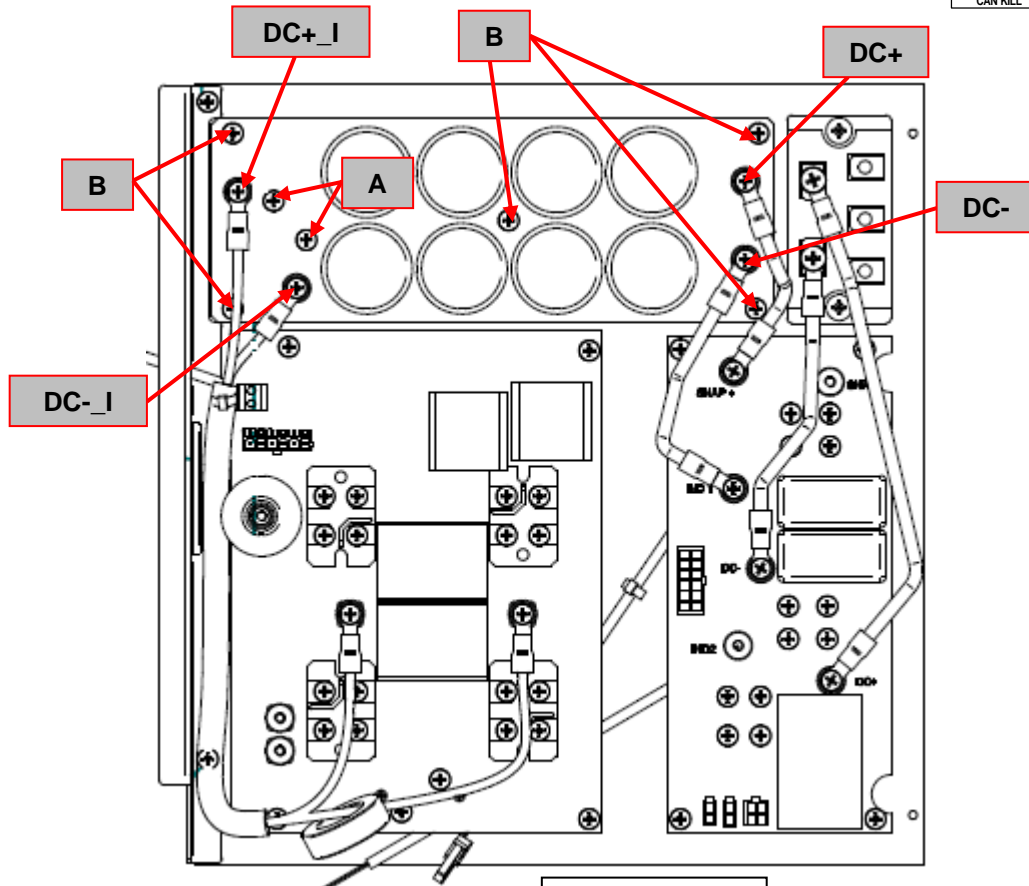

Figure 27

REMOVAL PROCEDURE

Necessary tools:

- Phillips screwdriver PH02
- Torque wrench

1. Remove main input power to the ASPECT™300
2. Perform the **Case Removal** and **Discharge procedure**
3. Locate the Caps board W05X1470 on the right side of the machine, see **Figure 27**
4. Using the Phillips screwdriver remove the cables from terminal **DC+**, **DC-**, **DC+_I** and **DC-_I**. See **Figure 27**
5. Using the Phillips screwdriver remove the 2 screws (**A**) that connect the Caps board to the resistor R3. See **Figure 27**
6. Using the Phillips screwdriver remove the 5 screws (**B**) and remove carefully the Caps board from the machine. See **Figure 27**

!! During performing the following steps take note of the size and type of screws being removed and associated washers. Upon reassembly the same type and size screw and washers **MUST** be used.

REASSEMBLY PROCEDURE

1. Install the new Caps board using the 5 screws (**B**) previously removed. **Attention!**:Do not tighten these screws yet.
2. Mount the 2 screws (**A**) that fix the Caps board to resistor R3 (torque 1,2Nm max.).
3. Finish tightening the 5 screws (**B**) (torque 1,2Nm max.).
4. Using the screws previously removed reconnect the cables to terminal **DC+**, **DC-**, **DC+_I** and **DC-_I** (torque 1,5Nm max.). See **Figure 27**

DISASSEMBLY OPERATIONS

INVERTER BOARD REMOVAL AND REPLACEMENT PROCEDURE

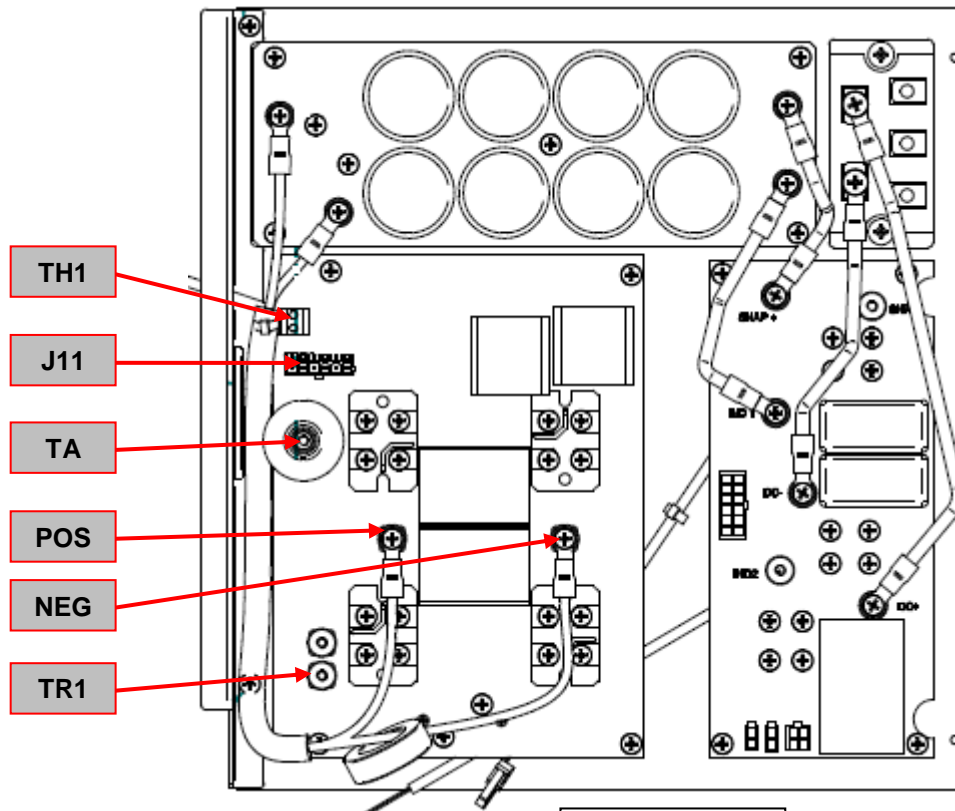
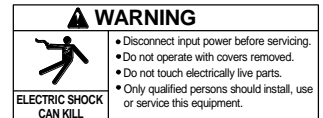

Figure 28

REMOVAL PROCEDURE

Necessary tools:

- Phillips screwdriver PH02
- Small Slot Head Screwdriver
- Torque wrench
- Dow Corning 340 Heat Sink Compound
- Silicon sealer

!! During performing the following steps take note of the size and type of screws being removed and associated washers. Upon reassembly the same type and size screw and washers **MUST** be used.

1. Remove main input power to the ASPECT™300
2. Perform the **Case Removal** and **Discharge procedure**
3. Locate the Inverter board W05X1327-3 on the right side of the machine, see **Figure 28**
4. Remove the connector **J11** from the Inverter board. See **Figure 28**
5. Using the small slot head screwdriver remove the two leads from the terminal **TH1**. See **Figure 28**
6. Using the phillips screwdriver remove and label the main transformer lead connected from the terminal **TA**. See **Figure 28**
7. Using the phillips screwdriver remove and label the main transformer lead connected from the terminal **TR1**. See **Figure 28**
8. Using the phillips screwdriver remove the red positive capacitor lead from **POS** terminal. See **Figure 28**
9. Using the phillips screwdriver remove the black negative capacitor lead from **NEG** terminal. See **Figure 28**

DISASSEMBLY OPERATIONS

INVERTER BOARD REMOVAL AND REPLACEMENT PROCEDURE (continued)

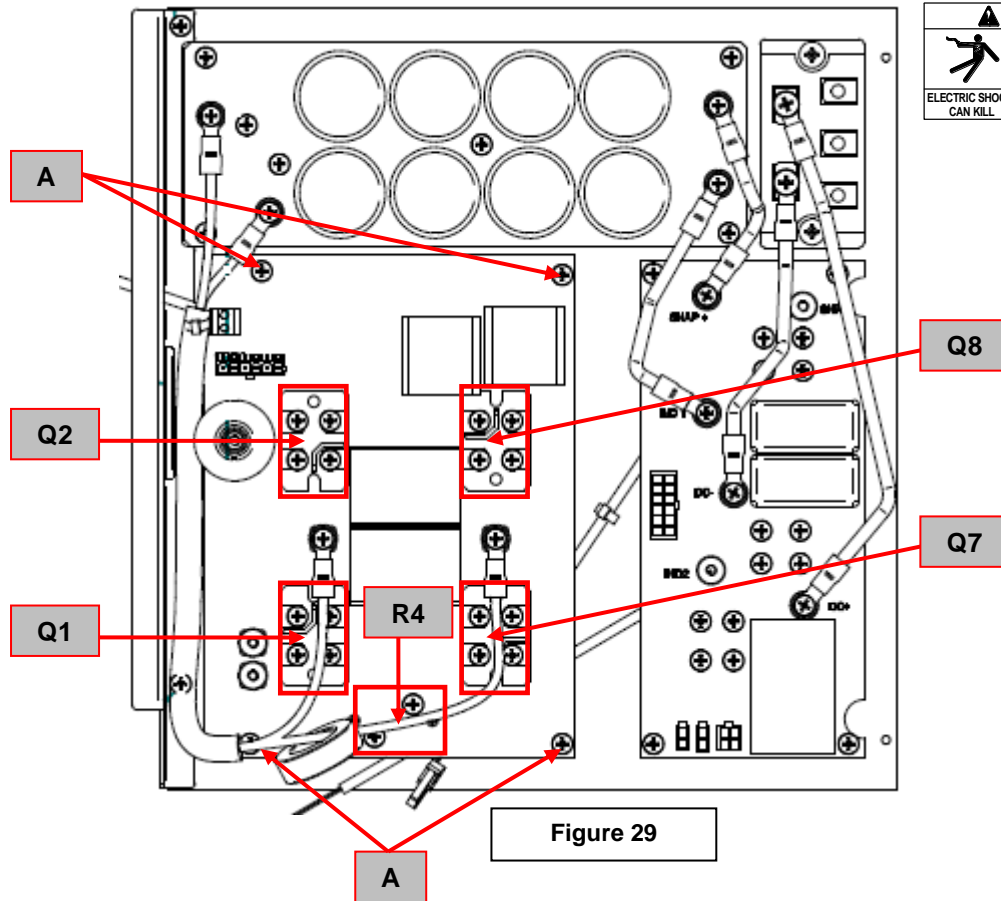

WARNING	
	<ul style="list-style-type: none"> • Disconnect input power before servicing. • Do not operate with covers removed. • Do not touch electrically live parts. • Only qualified persons should install, use or service this equipment.
ELECTRIC SHOCK CAN KILL	

Figure 29

10. Using the Phillips screwdriver remove the 4 screws from each module **Q1,Q2,Q7** and **Q8**. Carefully remove the silicon sealant to access the screws if present. See **Figure 29**
11. Using the Phillips screwdriver remove the 2 screws that fix the inverter board to the resistor **R4**. See **Figure 29**
12. Using the Phillips screwdriver remove the 4 screws (**A**) on the corners of the inverter board. See **Figure 29**
13. Carefully remove the Inverter board from the machine.
14. Carefully remove the 2 screws from the module(s) to be replaced. Take note of type and size of the mounting screws.

REASSEMBLY PROCEDURE

1. Clean the heat sink mounting surfaces from the old thermal compound.
2. Apply a thin layer of new thermal compound to the new module(s) mating surface (Dow Corning 340)
3. Carefully assemble the new module(s) to the heat sink in the correct position using the 2 screws previously removed (torque 1,5Nm max.). Be carefully about component type and polarity. One end of the module has an hole and the other end has a "U", new module(s) must be mounted in the same configuration
4. Install the inverter board using the 4 screws (**A**) previously removed from the board corners. **Attention!:** Do not tighten these screws yet. (torque 0,8Nm max.)
5. Mount the 4 screws previously removed from each module **Q1,Q2,Q7** and **Q8** (torque 1,2Nm max.). Seal screw heads with silicon.
6. Mount the 2 screws previously removed from the resistor **R4** (torque 1,2Nm max.). Seal screw heads with silicon.
7. Finish tightening the 4 Inverter board corner screws (torque 1,2Nm max.).
8. Reconnect the black negative capacitor lead to **NEG** terminal (torque 1,5Nm max.). See **Figure 28**
9. Reconnect the red positive capacitor lead to **POS** terminal (torque 1,5Nm max.). See **Figure 28**
10. Reconnect the main transformer lead to **TA** terminal (torque 1,5Nm max.). See **Figure 28**
11. Reconnect the main transformer lead to **TR1** terminal (torque 1,5Nm max.). See **Figure 28**
12. Using the small slot head screwdriver reconnect the two leads to the terminal **TH1**. See **Figure 28**
13. Reconnect the connector **J11** to the correct receptacle on inverter board. See **Figure 28**

PAY ATTENTION! of how to position the open end mounting of modules to heat-sink.

See printed circuit board for reference

DO NOT USE CORDLESS SCREWDRIVERS FOR THE POWER MODULES!



DISASSEMBLY OPERATIONS

INPUT POWER BOARD REMOVAL AND REPLACEMENT PROCEDURE

⚠ WARNING	
	<ul style="list-style-type: none">• Disconnect input power before servicing.• Do not operate with covers removed.• Do not touch electrically live parts.• Only qualified persons should install, use or service this equipment.
ELECTRIC SHOCK CAN KILL	

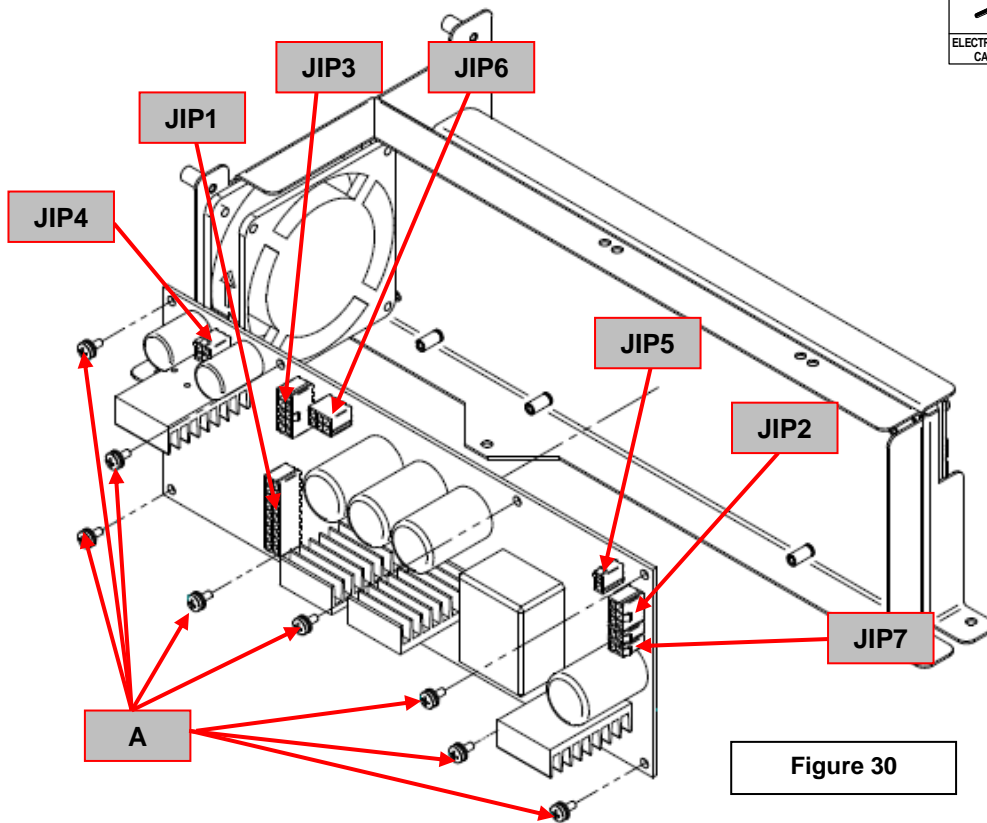

Figure 30

REMOVAL PROCEDURE

Necessary tools:

- Phillips screwdriver PH02
- Torque wrench

1. Remove main input power to the ASPECT™300
2. Perform the **Case Removal** and **Discharge procedure**
3. Locate the Input Power board W05X1461 on the upper left side of the machine, see **Figure 30**
4. Remove the connectors **JIP1**, **JIP2**, **JIP3**, **JIP4**, **JIP5**, **JIP6** and **JIP7** from the Input Power board. See **Figure 30**
5. Using the phillips screwdriver remove the 8 screws (**A**) that fix the Input Power board to the machine frame. See **Figure 30**
6. Carefully Remove the Input Power Board from the machine.
7. **For the Input Power Board re-assembly operations**, make the previous steps in the reverse order. Screw torque 2 N/m

DISASSEMBLY OPERATIONS

INPUT CONTROL BOARD REMOVAL AND REPLACEMENT PROCEDURE

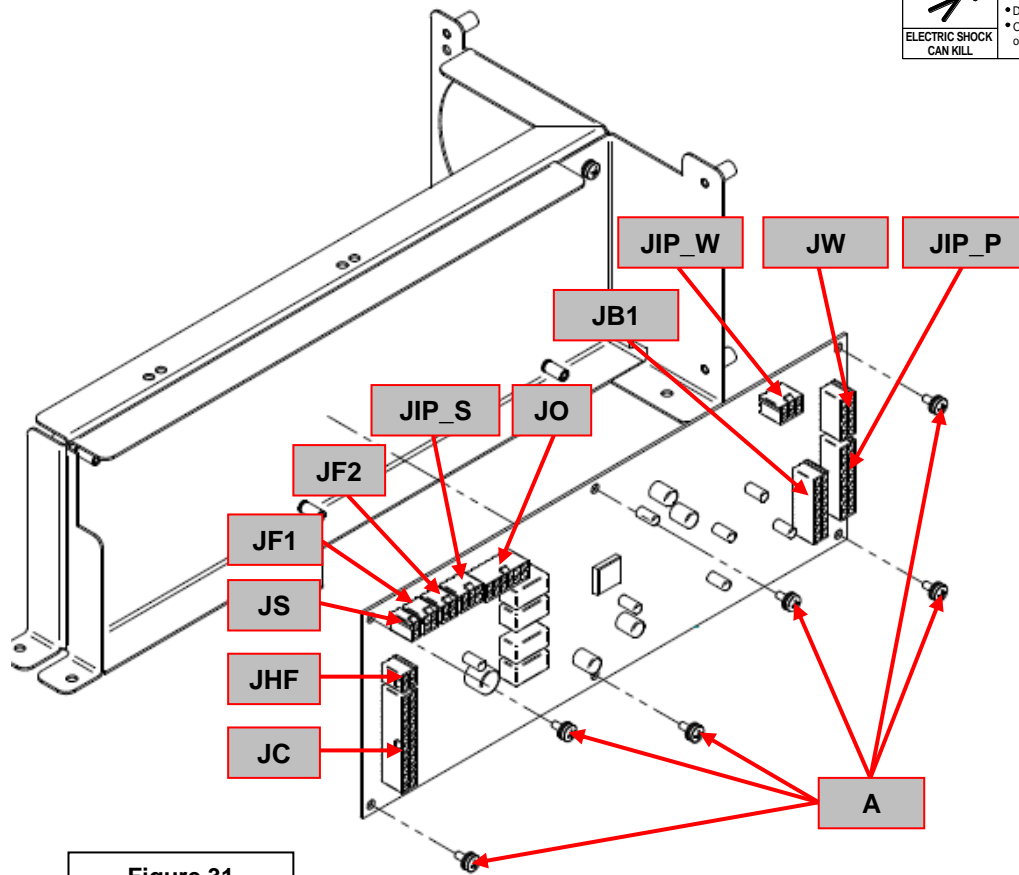
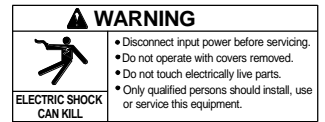

Figure 31

REMOVAL PROCEDURE

Necessary tools:

- Phillips screwdriver PH02
- Torque wrench

1. Remove main input power to the ASPECT™300
2. Perform the **Case Removal** and **Discharge procedure**
3. Locate the Input Control board W05X1460 on the upper right side of the machine, see **Figure 31**
4. Remove the connectors **JC, JHF, JS, JF1, JF2, JIP_S, JO, JB1, JIP_W, JW** and **JIP_P**, see **Figure 31**
5. Using the phillips screwdriver remove the 6 screws (**A**) that fix the Input Control board to the machine frame. See **Figure 31**
6. Carefully Remove the Input Control Board from the machine.
7. **For the Input Control Board re-assembly operations**, make the previous steps in the reverse order. Screw torque 2 N/m

DISASSEMBLY OPERATIONS

OUTPUT BOARD REMOVAL AND REPLACEMENT PROCEDURE

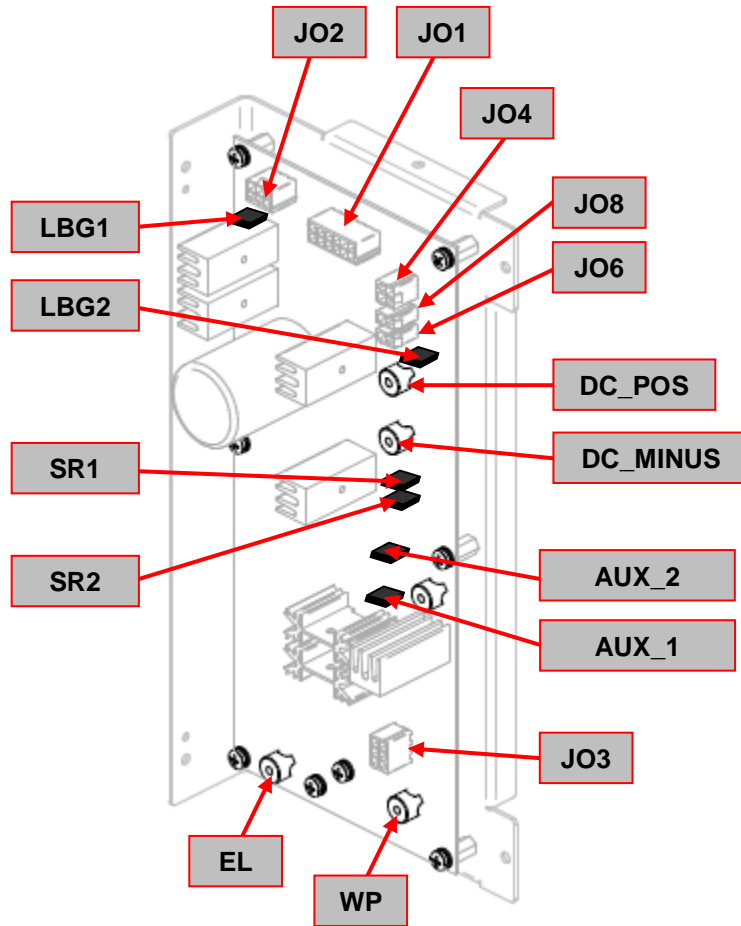
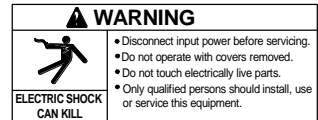

Figure 32

REMOVAL PROCEDURE

Necessary tools:

- Phillips screwdriver PH02
- Small pliers
- Torque wrench

!! During performing the following steps take note of the size and type of screws being removed and associated washers. Upon reassembly the same type and size screw and washers **MUST** be used.

1. Remove main input power to the ASPECT™300
2. Perform the **Case Removal and Discharge procedure**
3. Locate the Output board W05X1527 on the left side of the machine, see **Figure 32**
4. Remove the connectors **JO1, JO2, JO3, JO4, JO6** and **JO8**. See **Figure 32**
5. Remove and label the connectors **JO6** and **JO8**. See **Figure 32**
6. Using small pliers disconnect and label cables from terminals **LBG1, LBG2, SR1, SR2, AUX_1** and **AUX_2**. See **Figure 32**
7. Using the phillips screwdriver remove and label the leads connected to the terminals **DC_POS** and **DC_MINUS**. See **Figure 32**
8. Using the phillips screwdriver remove and label the leads connected to the terminals **EL** and **WP**. See **Figure 32**

DISASSEMBLY OPERATIONS

OUTPUT BOARD REMOVAL AND REPLACEMENT PROCEDURE (continued)

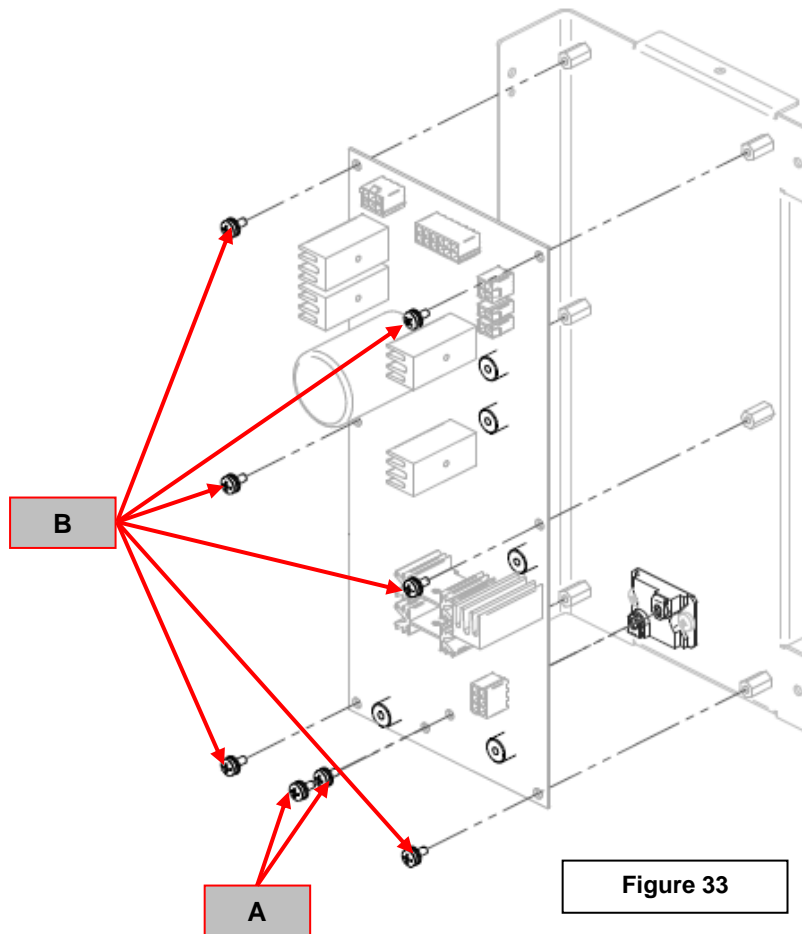
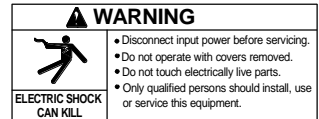

Figure 33

9. Using the phillips screwdriver remove the 2 screws (**A**) that fix the output board to the resistor **R20**.
See **Figure 33**
10. Using the phillips screwdriver remove the 6 screws (**B**) that fix the output board to the machine frame.
See **Figure 33**
11. Carefully remove the Output Control Board from the machine

REASSEMBLY PROCEDURE

1. Install the new output board using the 6 screws (**B**) previously removed from the board. **Attention!:** Do not tighten these screws yet.
2. Mount the 2 screws previously removed from the resistor **R20** (torque 0,8Nm max.).
3. Finish tightening the 6 screws (**B**), torque 1,5Nm max.
4. Using the phillips screwdriver reconnect the the leads previously removed to the terminals **EL** and **WP** (torque 1,5Nm max.). See **Figure 32**
5. Using the phillips screwdriver reconnect the the leads previously removed to the terminals **DC_POS** and **DC_MINUS** (torque 1,5Nm max.). See **Figure 32**
5. Reconnect the the leads previously removed to the terminals **LBG1**, **LBG2**, **SR1**, **SR2**, **AUX_1** and **AUX_2**.
See **Figure 32**
6. Reconnect the connectors **JO1**, **JO2**, **JO3**, **JO4**, **JO6** and **JO8** to the correct receptacles. See **Figure 32**

DO NOT USE CORDLESS SCREWDRIVERS FOR THE POWER MODULES!



DISASSEMBLY OPERATIONS

OUTPUT DIODE PCB REMOVAL AND REPLACEMENT PROCEDURE

WARNING	
	<ul style="list-style-type: none">• Disconnect input power before servicing.• Do not operate with covers removed.• Do not touch electrically live parts.• Only qualified persons should install, use or service this equipment.
ELECTRIC SHOCK CAN KILL	

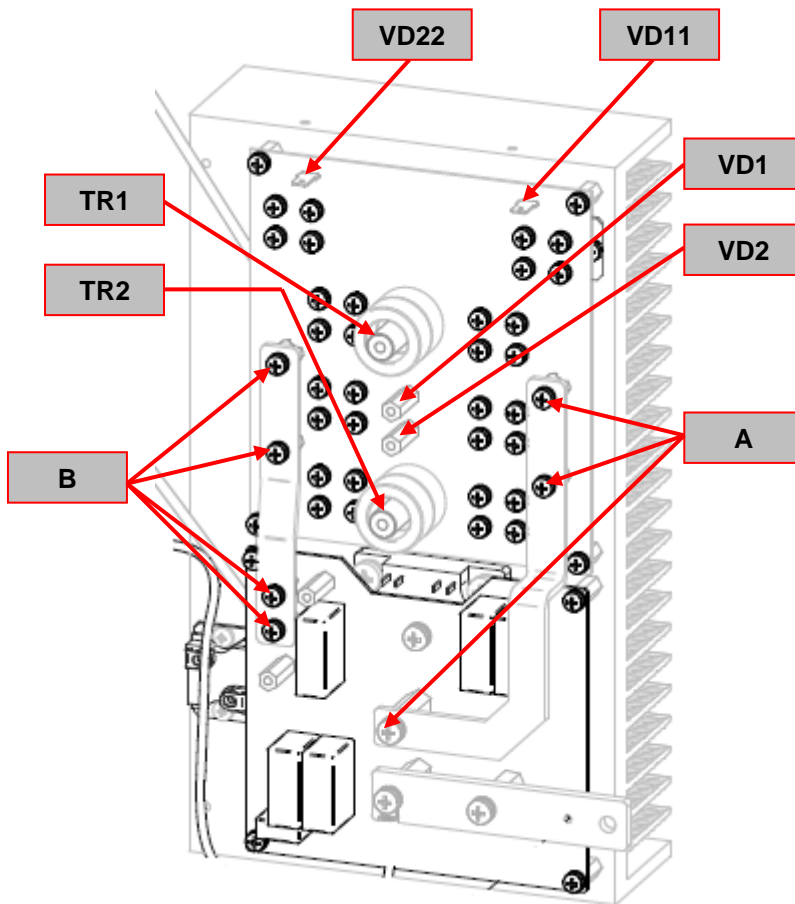

Figure 34

REMOVAL PROCEDURE

Necessary tools:

- Phillips screwdriver PH02
- Small pliers
- Torque wrench
- Dow Corning 340 Heat Sink Compound
- Silicon sealer

!! During performing the following steps take note of the size and type of screws being removed and associated washers. Upon reassembly the same type and size screw and washers **MUST** be used.

1. Remove main input power to the ASPECT™300
2. Perform the **Case Removal** and **Discharge procedure**
3. Locate the Output Diode board W05X1523 on the left side of the machine, see **Figure 34**
4. Using small pliers disconnect and label cables from terminals **VD11** and **VD22**.
See **Figure 34**
5. Using the phillips screwdriver remove and label the leads connected to the terminals **VD1** and **VD2**.
See **Figure 34**
6. Using the phillips screwdriver remove and label the main transformer leads connected to the terminals **TR1** and **TR2**. See **Figure 34**
7. Using the phillips screwdriver remove the 3 screws (**A**) from the right copper bar and carefully remove it.
8. Using the phillips screwdriver remove the 4 screws (**B**) from the left copper bar and carefully remove it.

DISASSEMBLY OPERATIONS

OUTPUT DIODE PCB REMOVAL AND REPLACEMENT PROCEDURE (continued)

⚠ WARNING	
	<ul style="list-style-type: none"> • Disconnect input power before servicing. • Do not operate with covers removed. • Do not touch electrically live parts. • Only qualified persons should install, use or service this equipment.
ELECTRIC SHOCK CAN KILL	

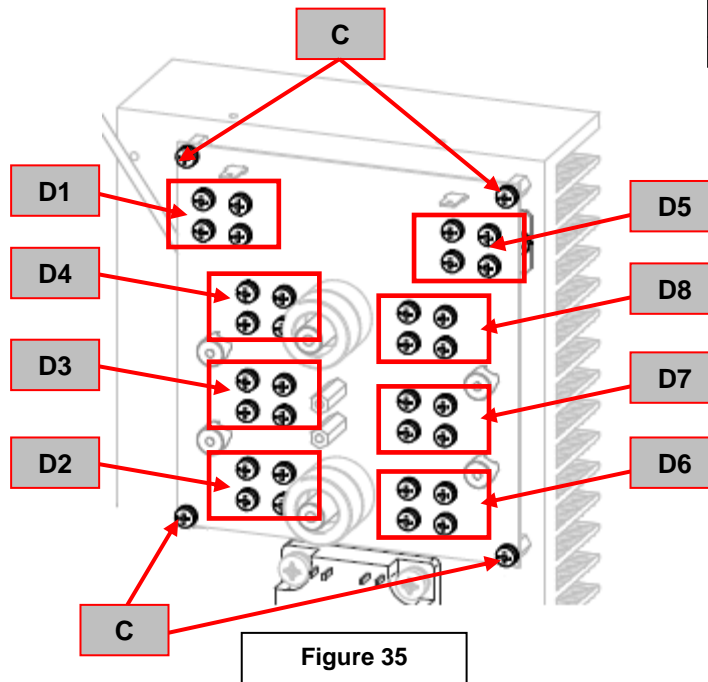

9. Using the Phillips screwdriver remove the 4 screws from each diode module **D1, D2, D3, D4, D5, D6, D7** and **D8**. Carefully remove the silicon sealant to access the screws if present. See **Figure 35**
10. Using the phillips screwdriver remove the 4 corner screws (**C**) that fix the Output Diode board. See **Figure 35**
11. Carefully remove Output Diode board from the machine.
12. Carefully remove the 2 screws from the diode module(s) to be replaced. Take note of type and size of the mounting screws

REASSEMBLY PROCEDURE

1. Clean the heat sink mounting surfaces from the old thermal compound.
2. Apply a thin layer of new thermal compound to the new Diode module(s) mating surface (Dow Corning 340)
3. Carefully assemble the new Diode module(s) to the heat sink in the correct position using the 2 screws previously removed (torque 1,3 Nm max.). Be carefully about component type and polarity. One end of the module has an hole and the other end has a "U", new modules(s) must be mounted in the same configuration.
4. Install the Output Diode board using the 4 screws (**A**) previously removed from the board corners. **Attention!:** Do not tighten these screws yet (torque 0,8Nm max.). See **Figure 35**
5. Mount the 4 screws previously removed from each module **D1, D2, D3, D4, D5, D6, D7** and **D8** (torque 1,2Nm max.). Seal screw heads with silicon. See **Figure 35**
6. Finish tightening the 4 Output Diode board corner screws (**C**) (torque 1,2Nm max.). See **Figure 35**
7. Using the phillips screwdriver reinstall the 3 screws (**A**) to the right copper bar. (torque 3Nm max.). See **Figure 34**
8. Using the phillips screwdriver reinstall the 4 screws (**B**) to the left copper bar. (torque 3Nm max.). See **Figure 34**
9. Reconnect the previously removed and labeled cables to terminals **VD11** and **VD22**. See **Figure 34**
10. Using the phillips screwdriver reconnect the previously removed and labeled leads to the terminals **VD1** and **VD2** (torque 3Nm max.). See **Figure 34**
11. Using the phillips screwdriver reconnect the previously removed and labeled main transformer leads to the terminals **TR1** and **TR2** (torque 3Nm max.). See **Figure 34**

PAY ATTENTION ! of how to position the open end mounting of modules to heat-sink.



See printed circuit board for reference

DO NOT USE CORDLESS SCREWDRIVERS FOR THE POWER MODULES!



DISASSEMBLY OPERATIONS

IGBT PCB AND IGBT MODULE REMOVAL AND REPLACEMENT PROCEDURE

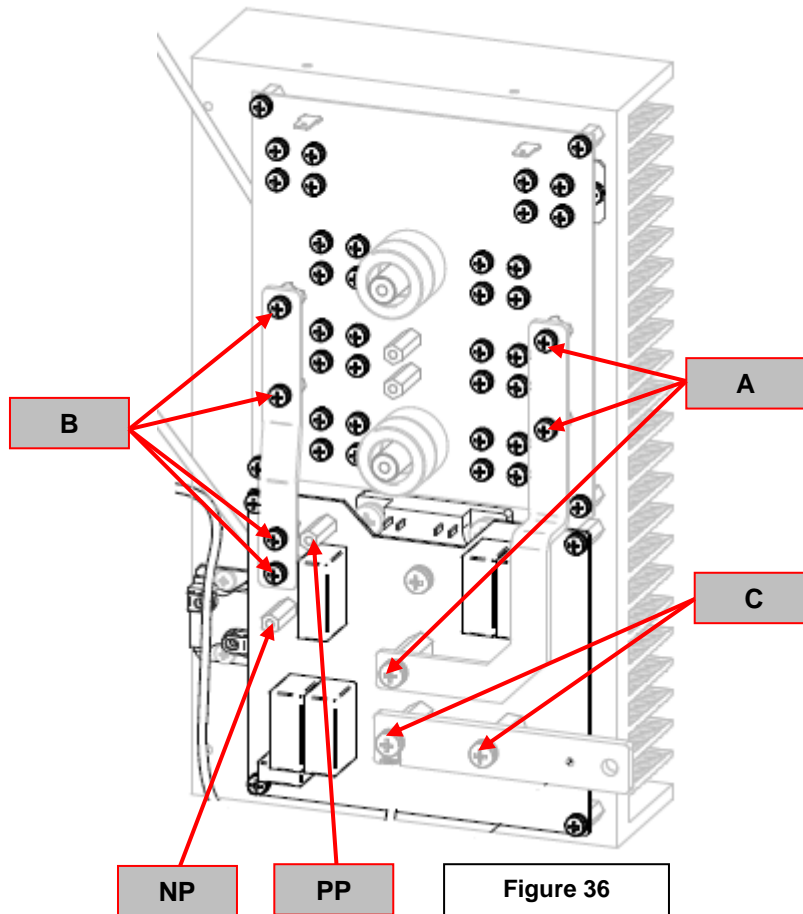
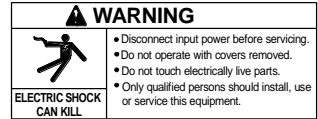

REMOVAL PROCEDURE

Necessary tools:

- Phillips screwdriver PH02
- 8mm wrench
- Small pliers
- Torque wrench
- Dow Corning 340 Heat Sink Compound

!! During performing the following steps take note of the size and type of screws being removed and associated washers. Upon reassembly the same type and size screw and washers **MUST** be used.

1. Remove main input power to the ASPECT™300
2. Perform the **Case Removal** and **Discharge procedure**
3. Locate the IGBT board W05X1524 on the left side of the machine, see **Figure 36**
4. Using the phillips screwdriver remove and label the leads connected to the terminals **PP** and **NP**.
See **Figure 36**
5. Using the phillips screwdriver remove the 3 screws (**A**) from the right copper bar and carefully remove it.
6. Using the phillips screwdriver remove the 4 screws (**B**) from the left copper bar and carefully remove it.
7. Using the phillips screwdriver remove the 2 screws (**C**) from the bottom copper bar and carefully remove it.

DISASSEMBLY OPERATIONS

IGBT PCB AND IGBT MODULE REMOVAL AND REPLACEMENT PROCEDURE (continued)

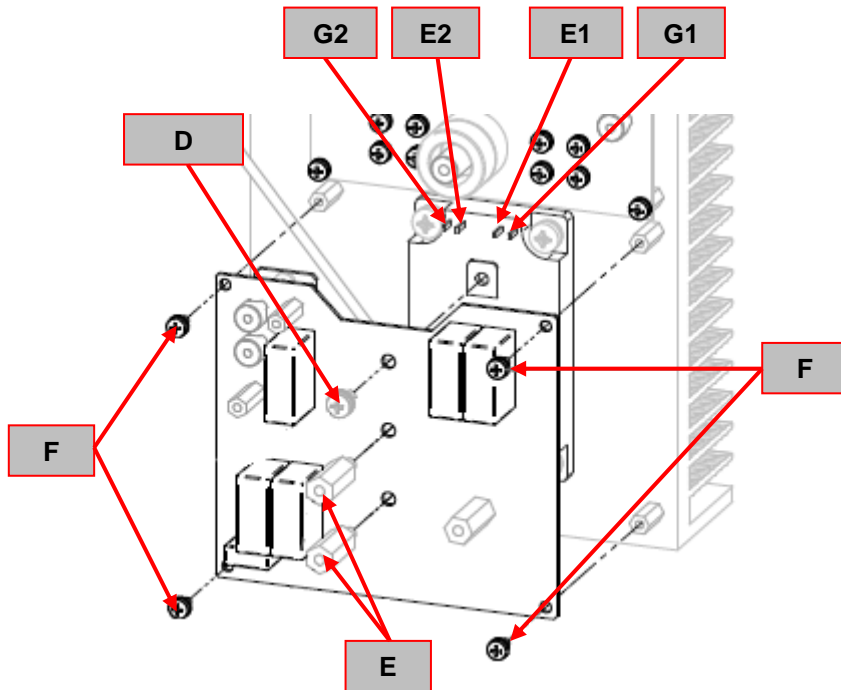
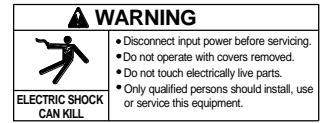

Figure 37



8. Using small pliers remove and label the leads connected to the IGBT module terminals **G2, E2, E1, G1**. See **Figure 37**
9. Using the phillips screwdriver remove the screw (**D**). See **Figure 37**
10. Using the 8 mm wrench remove the 2 standoff (**E**). See **Figure 37**
11. Using the phillips screwdriver remove the 4 corner screws (**F**) that fix the IGBT board. See **Figure 37**
12. Carefully remove the IGBT board from the machine.

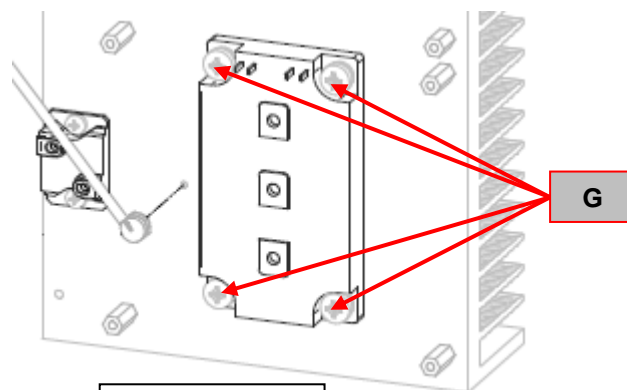

Figure 38

13. Using the phillips screwdriver remove the 4 screws (**G**) that fix the IGBT module to the heat sink. See **Figure 38**
14. Carefully remove the IGBT module from the machine.

DISASSEMBLY OPERATIONS

IGBT PCB AND IGBT MODULE REMOVAL AND REPLACEMENT PROCEDURE (continued)

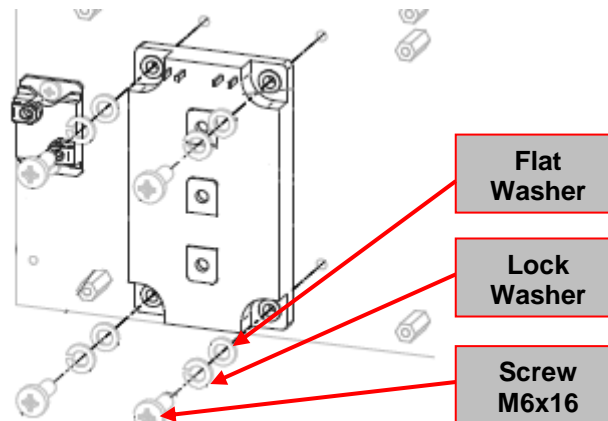
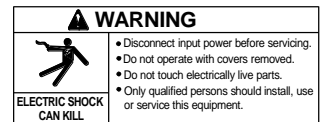

Figure 39

REASSEMBLY PROCEDURE

1. Clean the heat sink mounting surfaces from the old thermal compound.
2. Apply a thin layer of new thermal compound to the new IGBT module mating surface (Dow Corning 340)
3. Carefully assemble the new IGBT module to the heat sink in the correct position using the 4 screws (G) and correct sequence of washers as indicated in **Figure 39** (torque: min. 4 Nm – max. 6 Nm.)
4. Install the IGBT board using the 4 screws (F) previously removed from the board corners. See **Figure 37**.
Attention!: Do not tighten these screws yet (torque 0,8Nm max.).
5. Mount the screw (D) and the 2 standoff (E) previously removed (torque: min. 2 Nm – max. 4 Nm.). See **Figure 37**.
6. Finish tightening the 4 IGBT board corner screws (F) (torque 1,2Nm max.). See **Figure 37**
7. Reconnect the previously removed and labeled cables to IGBT module terminals G2, E2, E1, G1. See **Figure 37**
8. Using the phillips screwdriver reinstall the 2 screws (C) from the bottom copper bar (torque 3Nm max.). See **Figure 36**
9. Using the phillips screwdriver reinstall the 4 screws (B) from the left copper bar (torque 3Nm max.). See **Figure 36**
10. Using the phillips screwdriver reinstall the 3 screws (A) from the right copper bar (torque 3Nm max.). See **Figure 36**.
11. Using the phillips screwdriver reconnect the previously removed and labeled leads to the terminals PP and NP (torque 3Nm max.). See **Figure 36**

DO NOT USE CORDLESS SCREWDRIVERS FOR THE POWER MODULES!



DISASSEMBLY OPERATIONS

CONTROL BOARD REMOVAL AND REPLACEMENT PROCEDURE

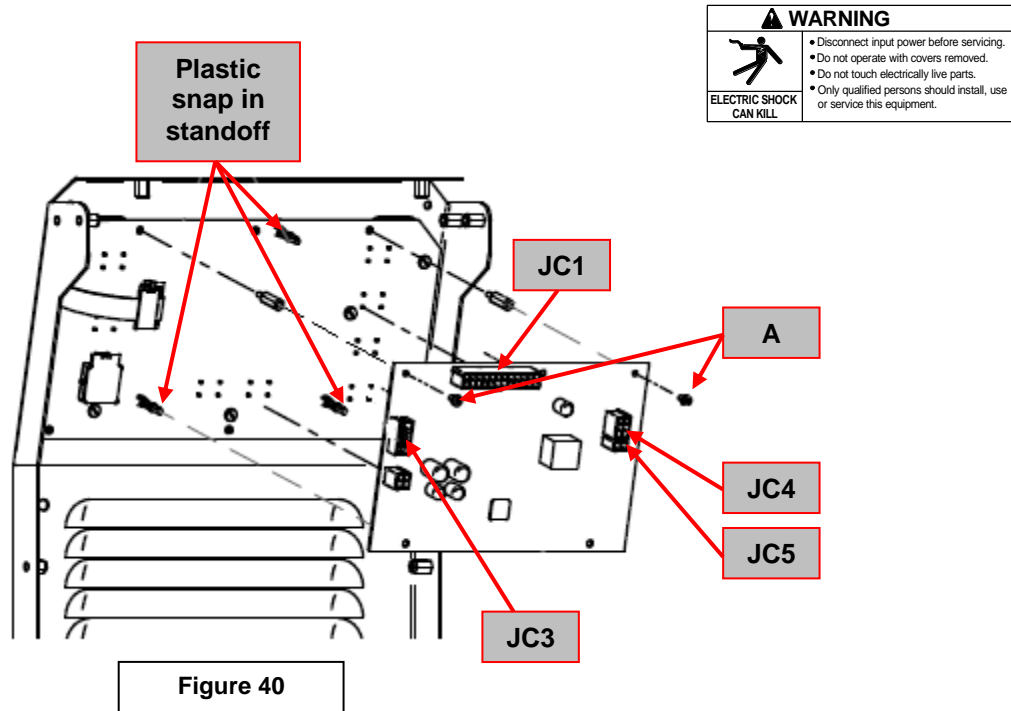

REMOVAL PROCEDURE

Necessary tools:

- Allen wrench 2,5mm
- Small pliers

1. Remove main input power to the ASPECT™300
2. Perform the **Case Removal and Discharge procedure**
3. Locate the Control board on W05X1462 or W05X1705-1 on the back upper part of the front panel, see **Figure 40**
4. Remove the connectors **JC1**, **JC3**, **JC4** and **JC5** from the Control board. See **Figure 40**
5. Using the 4mm allen wrench remove the 2 screws (**A**). See **Figure 40**
6. Using the small pliers unlock one by one, pulling carefully the Control board, the 3 plastic snap in standoff that are fixing the Control board to the User Interface board. See **Figure 40**
7. Remove carefully the Control board from the machine
8. **For the new Control board re-assembly operations**, make the previous steps in the reverse order

DISASSEMBLY OPERATIONS

USER INTERFACE BOARD AND LIGHT GUIDE REMOVAL AND REPLACEMENT PROCEDURE

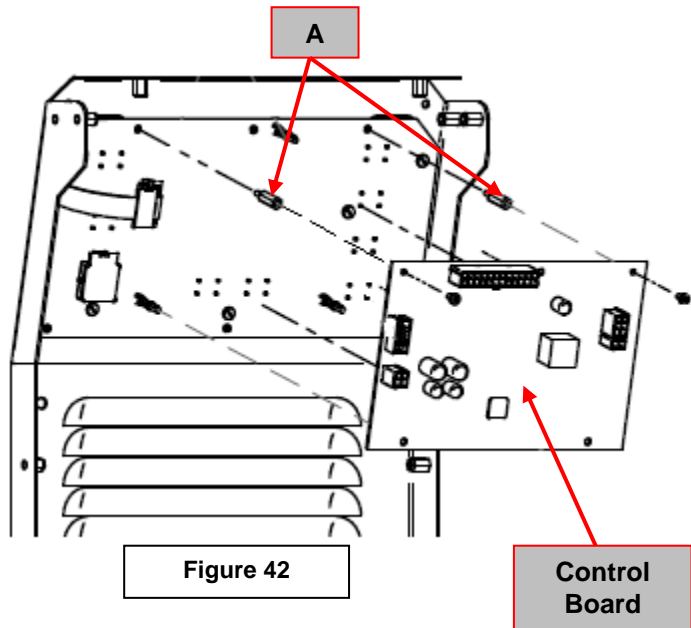
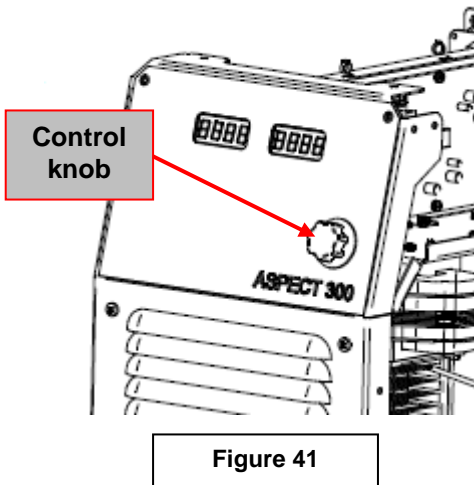
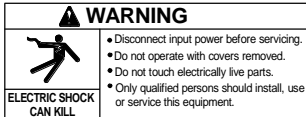

REMOVAL PROCEDURE

Necessary tools:

- Wrench 5,5 mm
- Allen wrench 2 mm
- Slot head screwdriver

1. Remove main input power to the ASPECT™300
2. Perform the **Case Removal and Discharge procedure**.
3. Locate the Control knob, see **Figure 41**
4. Using a 2 mm allen wrench loosen the knob retaining screw and remove the knob from the control encoder shaft.
5. Remove the Control board following the instructions provided in the previous page. See **Figure 42**
6. Using the 5,5mm wrench remove the 2 metal standoff (**A**). See **Figure 42**
7. Carefully pull the User Interface board W05X1649 or W05X1642-2 to be able to unlock it from the 5 metal locking pins.
8. Remove the User Interface together with the light guide from the machine.

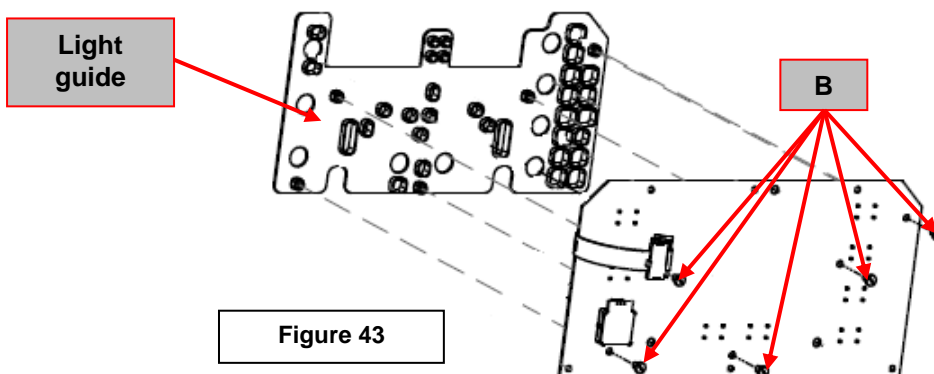

9. Using a slot head screwdriver carefully remove the 5 plastic screws (**B**) that fix the light guide to the User Interface board. See **Figure 43**
10. Remove the light guide from the User Interface board.
11. **For the new User Interface board re-assembly operations**, make the previous steps in the reverse order.

DISASSEMBLY OPERATIONS

HF BOARD REMOVAL AND REPLACEMENT PROCEDURE

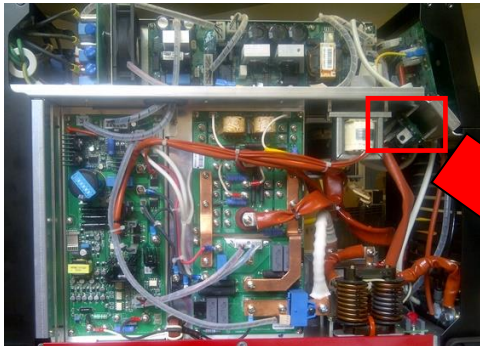
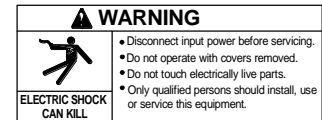

Figure 44

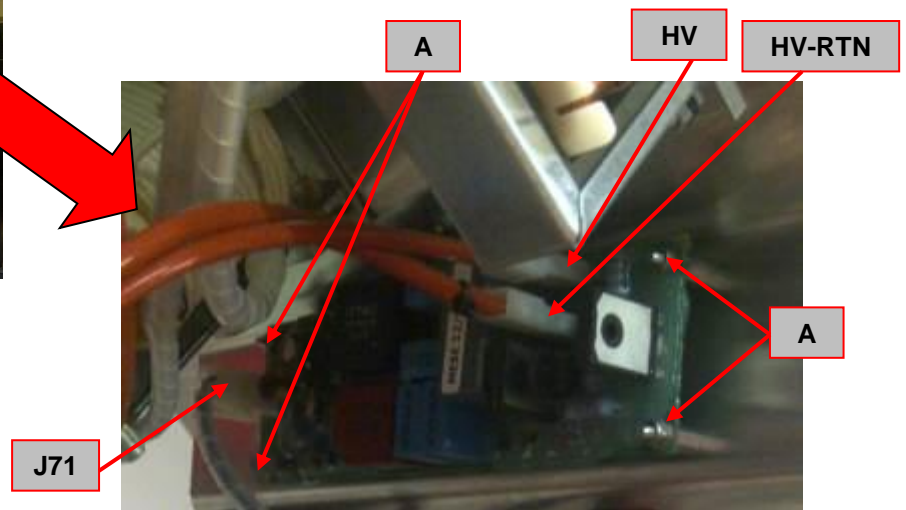

Figure 45

REMOVAL PROCEDURE

Necessary tools:

- Wrench 5,5 mm

1. Remove main input power to the ASPECT™300
2. Perform the **Case Removal** and **Discharge procedure**
3. Locate the HF board W05X1615, see **Figure 44**
4. Disconnect the two HF transformer terminals **HV** and **HV-RTN**. Take note about the lead marked with a black tie , it must be re-connected to the same terminal. See **Figure 45**
5. Remove connector **J71** from HF board. See **Figure 45**
6. Using the 5,5 mm wrench remove the 4 nuts (**A**) that fix the HF board to the machine frame. See **Figure 45**
7. Remove the HF board from the machine.
8. **For the HF board re-assembly operations**, make the previous steps in the reverse order. **Note:** the new HF board will come with the standoffs already mounted, remove them before reinstall the new board inside the machine (standoffs are already present on the machine frame, from the removal procedure sequence). This operation is suggested to avoid complete removal of machine front panel.

RETEST AFTER REPAIR

Should a machine under test be rejected for any reason requiring the removal of any mechanical part that could affect the machine's electrical characteristics, or if any electrical components are repaired or replaced, the machine must be retested.

Machine input and output

ASPECT™ 300

Input Voltage	Input Current	Rated Output
230Vac-3ph-50/60Hz	27,4A	Stick mode 270A/30,8V @35%
400Vac-3ph-50/60Hz	16,5A	Stick Mode 270A/30,8V @35%

Output Current/Voltage range	
STICK DC & AC	5A/20V - 270A/30,8V
TIG DC & AC	2A/10V – 300A/22V

Open Circuit Voltage	
STICK DC & AC	57 V
TIG HF DC & AC*	94V**

* Disconnect JP1 from HF board before measure this voltage with multimeter

** Available only for 3 seconds after trigger pressed

CALIBRATION PROCEDURE

Calibration must be done every time the control board is replaced!

NOTE: the external reference voltmeter must to be connected as close as possible to output dines to minimize the difference in reading between internal meter and external instrument.

Note: during calibration the menu LED is lit on during all the process.

1.1.1. Set up

Connect the trigger connector and close the trigger.

- Make sure that the correct load is connected and set for I₂ 270A output. [$U_2 = (20 + 0,04 * I_2)$]
- Holding the WAVE SHAPE, SEL and PULSE push buttons, switch ON the unit.
- The displays will show CALI PROC after the power-up sequence is complete.
- Wait until the precharge is completed and the displays blink showing SET CUR?
- Push SEL to go forward. The displays show ISET 270
- Push SEL to confirm. The displays show ENBL OUT?
 - Leds DC polarity and Output ON are lit ON.
- Push SEL to go forward.
- The displays show OUTP ENBL

1.1.2. Output adjustment

- Push SEL to go forward. The displays show ADJ 270.
- Push SEL to go forward. The displays show ADJ and a number.
- Turn the encoder clockwise to increase the output current, counterclockwise to decrease it, until the current meter shows 270.
- Push SEL to go forward.

1.1.3. Current meter calibration

- The left displays shows CURR and the right displays the output of the internal current meter.
- Turn the encoder clockwise to increase the reading, counterclockwise to decrease it, until the internal current meter matches the readout of the external reference meter.
- Push SEL to confirm.

1.1.4. Voltage meter calibration

- The displays start blinking:
- The left displays shows MSTR and the right displays the output of the internal voltage meter.
- Push SEL to go forward. The displays stop blinking
- Turn the encoder clockwise to increase the reading, counterclockwise to decrease it, until the internal voltage meter matches the readout of the external reference meter.
- Push SEL to confirm.
- The displays show the voltage and current meters.

1.1.5. Burn-in

- Push SEL to go forward. The displays show BURN IN and the output is switched to AC. **(A)**
 - Leds AC polarity and Output ON are lit ON
- Wait until the thermal protection is engaged, then the output is disabled, the fans will start and the displays show COOL DOWN.
- Thermal Led is ON; polarity and output leds are OFF.
- After the unit has finished cooling (about 50s) the output will be resumed for 10 seconds.
 - Thermal led is OFF; AC polarity and Output led are ON.
- The displays show CALI COMP.
- Turn OFF the machine.

To Skip the Burn-in

- At point **(A)** of the above section 1.1.5, press SEL to stop the burn in procedure.
- The displays show CALI COMP.
- Turn OFF the machine.

Open Trigger button when calibration is completed.

ELECTRICAL SCHEMATICS

Block Diagram :

ASPECT 300 code 52125

