

Operator's Manual

FLEXTEC™ 650

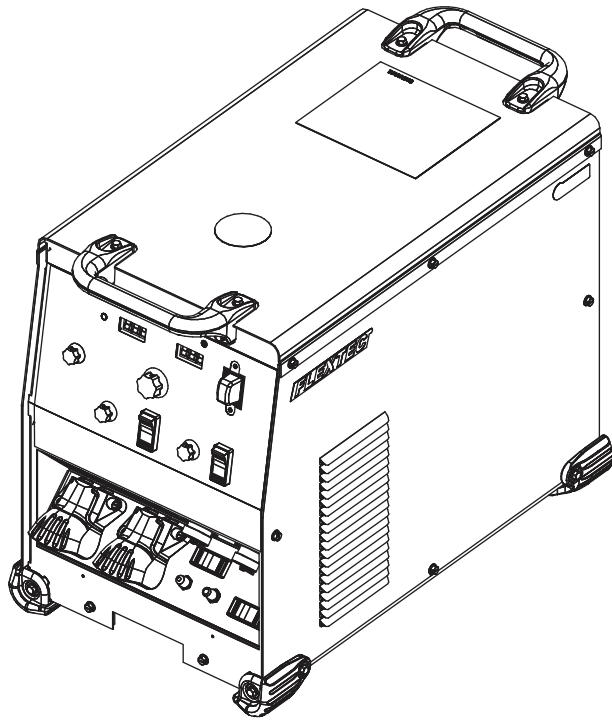

For use with machines having Code Numbers:
11936, 12340, 12621



Register your machine:

www.lincolnelectric.com/register

Authorized Service and Distributor Locator:

www.lincolnelectric.com/locator

Save for future reference

Date Purchased

Code: (ex: 10859)

Serial: (ex: U1060512345)

THANK YOU FOR SELECTING A QUALITY PRODUCT BY LINCOLN ELECTRIC.

PLEASE EXAMINE CARTON AND EQUIPMENT FOR DAMAGE IMMEDIATELY

When this equipment is shipped, title passes to the purchaser upon receipt by the carrier. Consequently, claims for material damaged in shipment must be made by the purchaser against the transportation company at the time the shipment is received.

SAFETY DEPENDS ON YOU

Lincoln arc welding and cutting equipment is designed and built with safety in mind. However, your overall safety can be increased by proper installation ... and thoughtful operation on your part. **DO NOT INSTALL, OPERATE OR REPAIR THIS EQUIPMENT WITHOUT READING THIS MANUAL AND THE SAFETY PRECAUTIONS CONTAINED THROUGHOUT.** And, most importantly, think before you act and be careful.

WARNING

This statement appears where the information must be followed exactly to avoid serious personal injury or loss of life.

CAUTION

This statement appears where the information must be followed to avoid minor personal injury or damage to this equipment.



KEEP YOUR HEAD OUT OF THE FUMES.

DON'T get too close to the arc. Use corrective lenses if necessary to stay a reasonable distance away from the arc.

READ and obey the Safety Data Sheet (SDS) and the warning label that appears on all containers of welding materials.

USE ENOUGH VENTILATION or exhaust at the arc, or both, to keep the fumes and gases from your breathing zone and the general area.

IN A LARGE ROOM OR OUTDOORS, natural ventilation may be adequate if you keep your head out of the fumes (See below).

USE NATURAL DRAFTS or fans to keep the fumes away from your face.

If you develop unusual symptoms, see your supervisor. Perhaps the welding atmosphere and ventilation system should be checked.

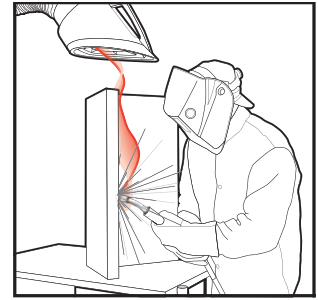

WEAR CORRECT EYE, EAR & BODY PROTECTION

PROTECT your eyes and face with welding helmet properly fitted and with proper grade of filter plate (See ANSI Z49.1).

PROTECT your body from welding spatter and arc flash with protective clothing including woolen clothing, flame-proof apron and gloves, leather leggings, and high boots.

PROTECT others from splatter, flash, and glare with protective screens or barriers.

IN SOME AREAS, protection from noise may be appropriate.

BE SURE protective equipment is in good condition.

Also, wear safety glasses in work area **AT ALL TIMES.**



SPECIAL SITUATIONS

DO NOT WELD OR CUT containers or materials which previously had been in contact with hazardous substances unless they are properly cleaned. This is extremely dangerous.

DO NOT WELD OR CUT painted or plated parts unless special precautions with ventilation have been taken. They can release highly toxic fumes or gases.

Additional precautionary measures

PROTECT compressed gas cylinders from excessive heat, mechanical shocks, and arcs; fasten cylinders so they cannot fall.

BE SURE cylinders are never grounded or part of an electrical circuit.

REMOVE all potential fire hazards from welding area.

ALWAYS HAVE FIRE FIGHTING EQUIPMENT READY FOR IMMEDIATE USE AND KNOW HOW TO USE IT.



SECTION A: WARNINGS



CALIFORNIA PROPOSITION 65 WARNINGS



WARNING: Breathing diesel engine exhaust exposes you to chemicals known to the State of California to cause cancer and birth defects, or other reproductive harm.

- Always start and operate the engine in a well-ventilated area.
- If in an exposed area, vent the exhaust to the outside.
- Do not modify or tamper with the exhaust system.
- Do not idle the engine except as necessary.

For more information go to www.P65warnings.ca.gov/diesel

WARNING: This product, when used for welding or cutting, produces fumes or gases which contain chemicals known to the State of California to cause birth defects and, in some cases, cancer. (California Health & Safety Code § 25249.5 *et seq.*)



WARNING: Cancer and Reproductive Harm
www.P65warnings.ca.gov

ARC WELDING CAN BE HAZARDOUS. PROTECT YOURSELF AND OTHERS FROM POSSIBLE SERIOUS INJURY OR DEATH. KEEP CHILDREN AWAY. PACEMAKER WEARERS SHOULD CONSULT WITH THEIR DOCTOR BEFORE OPERATING.

Read and understand the following safety highlights. For additional safety information, it is strongly recommended that you purchase a copy of "Safety in Welding & Cutting - ANSI Standard Z49.1" from the American Welding Society, P.O. Box 351040, Miami, Florida 33135 or CSA Standard W117.2-1974. A Free copy of "Arc Welding Safety" booklet E205 is available from the Lincoln Electric Company, 22801 St. Clair Avenue, Cleveland, Ohio 44117-1199.

BE SURE THAT ALL INSTALLATION, OPERATION, MAINTENANCE AND REPAIR PROCEDURES ARE PERFORMED ONLY BY QUALIFIED INDIVIDUALS.



FOR ENGINE POWERED EQUIPMENT.

- 1.a. Turn the engine off before troubleshooting and maintenance work unless the maintenance work requires it to be running.
- 1.b. Operate engines in open, well-ventilated areas or vent the engine exhaust fumes outdoors.
- 1.c. Do not add the fuel near an open flame welding arc or when the engine is running. Stop the engine and allow it to cool before refueling to prevent spilled fuel from vaporizing on contact



with hot engine parts and igniting. Do not spill fuel when filling tank. If fuel is spilled, wipe it up and do not start engine until fumes have been eliminated.

- 1.d. Keep all equipment safety guards, covers and devices in position and in good repair. Keep hands, hair, clothing and tools away from V-belts, gears, fans and all other moving parts when starting, operating or repairing equipment.
- 1.e. In some cases it may be necessary to remove safety guards to perform required maintenance. Remove guards only when necessary and replace them when the maintenance requiring their removal is complete. Always use the greatest care when working near moving parts.
- 1.f. Do not put your hands near the engine fan. Do not attempt to override the governor or idler by pushing on the throttle control rods while the engine is running.
- 1.g. To prevent accidentally starting gasoline engines while turning the engine or welding generator during maintenance work, disconnect the spark plug wires, distributor cap or magneto wire as appropriate.
- 1.h. To avoid scalding, do not remove the radiator pressure cap when the engine is hot.



ELECTRIC AND MAGNETIC FIELDS MAY BE DANGEROUS



- 2.a. Electric current flowing through any conductor causes localized Electric and Magnetic Fields (EMF). Welding current creates EMF fields around welding cables and welding machines
- 2.b. EMF fields may interfere with some pacemakers, and welders having a pacemaker should consult their physician before welding.
- 2.c. Exposure to EMF fields in welding may have other health effects which are now not known.
- 2.d. All welders should use the following procedures in order to minimize exposure to EMF fields from the welding circuit:
 - 2.d.1. Route the electrode and work cables together - Secure them with tape when possible.
 - 2.d.2. Never coil the electrode lead around your body.
 - 2.d.3. Do not place your body between the electrode and work cables. If the electrode cable is on your right side, the work cable should also be on your right side.
 - 2.d.4. Connect the work cable to the workpiece as close as possible to the area being welded.
 - 2.d.5. Do not work next to welding power source.



ELECTRIC SHOCK CAN KILL.



- 3.a. The electrode and work (or ground) circuits are electrically “hot” when the welder is on. Do not touch these “hot” parts with your bare skin or wet clothing. Wear dry, hole-free gloves to insulate hands.
- 3.b. Insulate yourself from work and ground using dry insulation. Make certain the insulation is large enough to cover your full area of physical contact with work and ground.

In addition to the normal safety precautions, if welding must be performed under electrically hazardous conditions (in damp locations or while wearing wet clothing; on metal structures such as floors, gratings or scaffolds; when in cramped positions such as sitting, kneeling or lying, if there is a high risk of unavoidable or accidental contact with the workpiece or ground) use the following equipment:

- Semiautomatic DC Constant Voltage (Wire) Welder.
 - DC Manual (Stick) Welder.
 - AC Welder with Reduced Voltage Control.
- 3.c. In semiautomatic or automatic wire welding, the electrode, electrode reel, welding head, nozzle or semiautomatic welding gun are also electrically “hot”.
 - 3.d. Always be sure the work cable makes a good electrical connection with the metal being welded. The connection should be as close as possible to the area being welded.
 - 3.e. Ground the work or metal to be welded to a good electrical (earth) ground.
 - 3.f. Maintain the electrode holder, work clamp, welding cable and welding machine in good, safe operating condition. Replace damaged insulation.
 - 3.g. Never dip the electrode in water for cooling.
 - 3.h. Never simultaneously touch electrically “hot” parts of electrode holders connected to two welders because voltage between the two can be the total of the open circuit voltage of both welders.
 - 3.i. When working above floor level, use a safety belt to protect yourself from a fall should you get a shock.
 - 3.j. Also see Items 6.c. and 8.



ARC RAYS CAN BURN.



- 4.a. Use a shield with the proper filter and cover plates to protect your eyes from sparks and the rays of the arc when welding or observing open arc welding. Headshield and filter lens should conform to ANSI Z87.1 standards.
- 4.b. Use suitable clothing made from durable flame-resistant material to protect your skin and that of your helpers from the arc rays.
- 4.c. Protect other nearby personnel with suitable, non-flammable screening and/or warn them not to watch the arc nor expose themselves to the arc rays or to hot spatter or metal.



FUMES AND GASES CAN BE DANGEROUS.



- 5.a. Welding may produce fumes and gases hazardous to health. Avoid breathing these fumes and gases. When welding, keep your head out of the fume. Use enough ventilation and/or exhaust at the arc to keep fumes and gases away from the breathing zone. **When welding hardfacing (see instructions on container or SDS) or on lead or cadmium plated steel and other metals or coatings which produce highly toxic fumes, keep exposure as low as possible and within applicable OSHA PEL and ACGIH TLV limits using local exhaust or mechanical ventilation unless exposure assessments indicate otherwise. In confined spaces or in some circumstances, outdoors, a respirator may also be required. Additional precautions are also required when welding on galvanized steel.**
- 5.b. The operation of welding fume control equipment is affected by various factors including proper use and positioning of the equipment, maintenance of the equipment and the specific welding procedure and application involved. Worker exposure level should be checked upon installation and periodically thereafter to be certain it is within applicable OSHA PEL and ACGIH TLV limits.
- 5.c. Do not weld in locations near chlorinated hydrocarbon vapors coming from degreasing, cleaning or spraying operations. The heat and rays of the arc can react with solvent vapors to form phosgene, a highly toxic gas, and other irritating products.
- 5.d. Shielding gases used for arc welding can displace air and cause injury or death. Always use enough ventilation, especially in confined areas, to insure breathing air is safe.
- 5.e. Read and understand the manufacturer’s instructions for this equipment and the consumables to be used, including the Safety Data Sheet (SDS) and follow your employer’s safety practices. SDS forms are available from your welding distributor or from the manufacturer.
- 5.f. Also see item 1.b.



WELDING AND CUTTING SPARKS CAN CAUSE FIRE OR EXPLOSION.

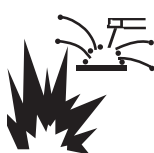

- 6.a. Remove fire hazards from the welding area. If this is not possible, cover them to prevent the welding sparks from starting a fire. Remember that welding sparks and hot materials from welding can easily go through small cracks and openings to adjacent areas. Avoid welding near hydraulic lines. Have a fire extinguisher readily available.
- 6.b. Where compressed gases are to be used at the job site, special precautions should be used to prevent hazardous situations. Refer to "Safety in Welding and Cutting" (ANSI Standard Z49.1) and the operating information for the equipment being used.
- 6.c. When not welding, make certain no part of the electrode circuit is touching the work or ground. Accidental contact can cause overheating and create a fire hazard.
- 6.d. Do not heat, cut or weld tanks, drums or containers until the proper steps have been taken to insure that such procedures will not cause flammable or toxic vapors from substances inside. They can cause an explosion even though they have been "cleaned". For information, purchase "Recommended Safe Practices for the Preparation for Welding and Cutting of Containers and Piping That Have Held Hazardous Substances", AWS F4.1 from the American Welding Society (see address above).
- 6.e. Vent hollow castings or containers before heating, cutting or welding. They may explode.
- 6.f. Sparks and spatter are thrown from the welding arc. Wear oil free protective garments such as leather gloves, heavy shirt, cuffless trousers, high shoes and a cap over your hair. Wear ear plugs when welding out of position or in confined places. Always wear safety glasses with side shields when in a welding area.
- 6.g. Connect the work cable to the work as close to the welding area as practical. Work cables connected to the building framework or other locations away from the welding area increase the possibility of the welding current passing through lifting chains, crane cables or other alternate circuits. This can create fire hazards or overheat lifting chains or cables until they fail.
- 6.h. Also see item 1.c.
- 6.i. Read and follow NFPA 51B "Standard for Fire Prevention During Welding, Cutting and Other Hot Work", available from NFPA, 1 Batterymarch Park, PO box 9101, Quincy, MA 022690-9101.
- 6.j. Do not use a welding power source for pipe thawing.



CYLINDER MAY EXPLODE IF DAMAGED.

- 7.a. Use only compressed gas cylinders containing the correct shielding gas for the process used and properly operating regulators designed for the gas and pressure used. All hoses, fittings, etc. should be suitable for the application and maintained in good condition. 
- 7.b. Always keep cylinders in an upright position securely chained to an undercarriage or fixed support.
- 7.c. Cylinders should be located:
 - Away from areas where they may be struck or subjected to physical damage.
 - A safe distance from arc welding or cutting operations and any other source of heat, sparks, or flame.
- 7.d. Never allow the electrode, electrode holder or any other electrically "hot" parts to touch a cylinder.
- 7.e. Keep your head and face away from the cylinder valve outlet when opening the cylinder valve.
- 7.f. Valve protection caps should always be in place and hand tight except when the cylinder is in use or connected for use.
- 7.g. Read and follow the instructions on compressed gas cylinders, associated equipment, and CGA publication P-1, "Precautions for Safe Handling of Compressed Gases in Cylinders," available from the Compressed Gas Association, 14501 George Carter Way Chantilly, VA 20151.



FOR ELECTRICALLY POWERED EQUIPMENT.



- 8.a. Turn off input power using the disconnect switch at the fuse box before working on the equipment.
- 8.b. Install equipment in accordance with the U.S. National Electrical Code, all local codes and the manufacturer's recommendations.
- 8.c. Ground the equipment in accordance with the U.S. National Electrical Code and the manufacturer's recommendations.

Refer to
<http://www.lincolnelectric.com/safety>
for additional safety information.

Installation	Section A
Technical Specifications	A-1, A-2
Safety Precautions	A-3
VRD™ (Voltage Reduction Device)	A-3
Select Suitable Location	A-3
Lifting	A-3
Stacking	A-3
Environmental Limitations	A-3
Input and Grounding Connections	A-3
High Frequency Protection	A-3
High Temperature Operation	A-3
Input Connection	A-4
Input Fuse and Supply Wire Considerations	A-4
Input Voltage Selection	A-4
Cable Connections	A-5
Recommended Electrode and Work Cable for Arc Welding	A-6
Output Cable Guidelines	A-6
Control Cable Connections, Paralleling	A-7
Connection Diagrams Flextec 650 to Wire Feeders and Tractor	A-8 thru A-12

Operation	Section B
Safety Precautions	B-1
Graphic Symbols	B-1, B-2
Product Description	B-2
Duty Cycle	B-2
Design Features	B-2
Recommended Processes and Equipment	B-3
Case Front Controls	B-4
Case Back Controls	B-5
Internal Controls	B-6
Power-Up Sequence	B-7
Common Welding Procedures, Weld Controls and Displays	B-7 thru B-10

Accessories	Section C
Options / Accessories	C-1

Maintenance	Section D
Safety Precautions	D-1
Visual Inspection	D-1
Routine Maintenance	D-1
Periodic Maintenance	D-1

Section E	Troubleshooting
How to Use Troubleshooting Guide	E-1
Troubleshooting Guide	E-2
Error Codes	E-3, E-4

Wiring Diagram and Dimension Print	Section F
---	------------------

Parts List	P-711 Series
-------------------------	---------------------

TECHNICAL SPECIFICATIONS - FLEXTEC™ 650

POWER SOURCE-INPUT VOLTAGE AND CURRENT					
Model	Duty Cycle	Input Voltage ± 10%	Input Amperes	Idle Power (W)	Power Factor @ Rated Output
K3060-2	60% rating	380 / 460 / 575 / 3 / 50 / 60	61 / 50 / 40	230 MAX.(Fan On)	88%
	100% rating		57 / 47 / 38	100 MAX. (Fan Off)	
RATED OUTPUT*					
Process	Duty Cycle	Amperes	Volts at Rated Amperes		
GMAW (CV)	60%	750 *	44V		
	100%	650 *			
GTAW (CC)	60%	750	34V		
	100%	650			
SMAW (CC)	60%	750 *	44V		
	100%	650 *			
FCAW-GS (CV)	60%	750 *			
	100%	650 *			
FCAW-SS (CV)	60%	750 *			
	100%	650 *			
SAW (CV)	60%	750 *			
	100%	650 *			

* Output is limited to 600A / 100% and 700A / 60% when used with K3091-1 Multi-Process Switch.

RECOMMENDED INPUT WIRE AND FUSE SIZES (1)					
VOLTAGE 50/60Hz	Maximum Input Amperes	Cord Size(3) AWG SIZES (mm)	Type 75°C Copper Wire in Conduit AWG (mm ²)	COPPER GROUNDING CONDUCTOR AWG (mm ²)	Fuse (Super Lag) or Breaker Size (2)
380/3/50	70 A	4(25)	4(25)	8 (10)	90
460/3/60	58 A	4(25)	6(16)	8 (10)	80
575/3/60	46 A	6(16)	8 (10)	10 (6)	60

- (1) Cord and Fuse Sizes based upon the U.S. National Electric Code and maximum output for 40°C (104°) ambient.
- (2) Also called “inverse time” or “thermal/magnetic” circuit breakers; circuit breakers that have a delay in tripping action that decreases as the magnitude of current increases.
- (3) Type SJ cord or similar in 30°C ambient.

WELDING PROCESS				
PROCESS	OUTPUT RANGE (AMPERES)		OCV (U_o)	OCV (U_r)
GMAW (CV)	40-815		60	---
GTAW (CC)	10-815		24	15
SMAW (CC)	15-815		60	15
FCAW-GS (CV)	40-815		60	---
FCAW-SS (CV)	40-815		60	---
SAW (CV)	40-815		60	---

PHYSICAL DIMENSIONS				
MODEL	HEIGHT	WIDTH	DEPTH	WEIGHT
K3060-2	21.8 in (554 mm)	16.14 in (410 mm)	29.33 in (745 mm)	165lbs (74.8kg)*

TEMPERATURE RANGES	
OPERATING TEMPERATURE RANGE Environmentally Hardened: 14°F to 131°F (-10°C to 55°C **)	STORAGE TEMPERATURE RANGE Environmentally Hardened: -40°F to 185°F (-40°C to 85°C)

IP23 180°(H) Insulation Class

* Weight does not include input cord.

** Power Source is de-rated at temperatures above 40C.

AUXILIARY RECONNECT INPUT RANGES		
"A" LEAD POSITION	VRD Enabled	VRD Disabled
380 Volt Reconnect	Low Limit - 340 Vac High Limit - 420 Vac	Low Limit - 340 Vac High Limit - 455 Vac
460 Volt Reconnect	Low Limit - 390 Vac High Limit - 505 Vac	Low Limit - 390 Vac High Limit - 520 Vac
575 Volt Reconnect	Low Limit - 485 Vac High Limit - 620 Vac	Low Limit - 485 Vac High Limit - 655 Vac

⚠ WARNING



ELECTRIC SHOCK can kill.

ONLY QUALIFIED PERSONNEL SHOULD PERFORM THIS INSTALLATION.

- **TURN OFF INPUT POWER TO THE POWER SOURCE AT THE DISCONNECT SWITCH OR FUSE BOX BEFORE WORKING ON THIS EQUIPMENT. TURN OFF THE INPUT POWER TO ANY OTHER EQUIPMENT CONNECTED TO THE WELDING SYSTEM AT THE DISCONNECT SWITCH OR FUSE BOX BEFORE WORKING ON THE EQUIPMENT.**
- **DO NOT TOUCH ELECTRICALLY HOT PARTS.**
- **ALWAYS CONNECT THE FLEXTEC™ 650 GROUNDING LUG (LOCATED INSIDE THE RECONNECT INPUT ACCESS DOOR) TO A PROPER SAFETY (EARTH) GROUND.**

VRD™ (VOLTAGE REDUCTION DEVICE)

The VRD™ feature provides additional safety in the CC-Stick mode. The VRD™ reduces the OCV (Open Circuit Voltage) at the welding output terminals while not welding to less than 35VDC peak.

The VRD™ requires that the welding cable connections be kept in good electrical condition because poor connections will contribute to poor starting. Having good electrical connections also limits the possibility of other safety issues such as heat-generated damage, burns and fires.

The machine is shipped with VRD™ “Disabled”. The VRD™ function can be disabled or enabled via dip switches on the control P.C. board. Dip switch setting will differ depending on input voltage.

The control board and dip switches can be accessed by removing the case top and side as shown in the **Operation Section** figure B.3.

SELECT SUITABLE LOCATION

LOCATION AND VENTILATION FOR COOLING

Place the welder where clean cooling air can freely circulate in through the rear louvers and out through the case sides. Dirt, dust, or any foreign material that can be drawn into the welder should be kept at a minimum. Failure to observe these precautions can result in excessive operating temperatures and nuisance shutdowns.

LIFTING

The FLEXTEC™ 650 has 2 lifting eyelets and 2 handles that can be used to lift the machine. Both handles or both eyelets should be used when lifting the FLEXTEC™ 650.

When using a crane or overhead device to lift using the handles, a lifting strap should be connected to both handles. Do not attempt to lift the FLEXTEC™ 650 with accessories attached to it.

TILTING

Place the machine directly on a secure, level surface or on a recommended undercarriage. The machine may topple over if this procedure is not followed.

STACKING

Multiple FLEXTEC™ 650's cannot be stacked.

ENVIRONMENTAL LIMITATIONS

The FLEXTEC™ 650 is IP23 rated for use in an outdoor environment. The FLEXTEC™ 650 should not be subjected to falling water during use nor should any parts of it be submerged in water. Doing so may cause improper operation as well as pose a safety hazard. The best practice is to keep the machine in a dry, sheltered area.

⚠ CAUTION

Do not mount the FLEXTEC™ 650 over combustible surfaces. Where there is a combustible surface directly under stationary or fixed electrical equipment, that surface shall be covered with a steel plate at least .060” (1.6mm) thick, which shall extend not less than 5.90” (150mm) beyond the equipment on all sides.

INPUT AND GROUNDING CONNECTIONS

MACHINE GROUNDING



The frame of the welder must be grounded. A ground terminal marked with the symbol shown is located inside the reconnect/input connection area for this purpose. See your local and national electrical codes for proper grounding methods.

HIGH FREQUENCY PROTECTION

Locate the FLEXTEC™ 650 away from radio controlled machinery. The normal operation of the FLEXTEC™ 650 may adversely affect the operation of RF controlled equipment, which may result in bodily injury or damage to the equipment.

HIGH TEMPERATURE OPERATION

WELDER OUTPUT RATINGS AT 55°C ELEVATED TEMPERATURES			
AMPS	DUTY CYCLE	VOLTS	TEMPERATURES
600	100%	44V	55°C
650	50%		
750	30%		

⚠ WARNING



ELECTRIC SHOCK can kill.

ONLY A QUALIFIED ELECTRICIAN SHOULD CONNECT THE INPUT LEADS TO THE FLEXTEC™ 650. CONNECTIONS SHOULD BE MADE IN ACCORDANCE WITH ALL LOCAL AND NATIONAL ELECTRICAL CODES AND THE CONNECTION DIAGRAM LOCATED ON THE INSIDE OF THE RECONNECT/INPUT ACCESS DOOR OF THE MACHINE. FAILURE TO DO SO MAY RESULT IN BODILY INJURY OR DEATH.

INPUT CONNECTION

(See Figure A.1)

Use a three-phase supply line. A 1.75 inch (45 mm) diameter access hole for the input supply is located on the case back. Remove the reconnect access panel located on the case back and connect W, V, U and ground according to the Input Supply Connection Diagram decal.

INPUT FUSE AND SUPPLY WIRE CONSIDERATIONS

Refer to Specification in this Installation Section for recommended fuse, wire sizes and type of the copper wires. Fuse the input circuit with the recommended super lag fuse or delay type breakers (also called "inverse time" or "thermal/magnetic" circuit breakers). Choose input and grounding wire size according to local or national electrical codes. Using input wire sizes, fuses or circuit breakers smaller than recommended may result in "nuisance" shut-offs from welder inrush currents, even if the machine is not being used at high currents.

INPUT VOLTAGE SELECTION

Welders are shipped connected for 460 Volt input voltage. To move this connection to a different input voltage, see Figure A.1 which is illustrated below. Refer to Auxiliary Reconnect Input Ranges table in the **Technical Specification Section**. If the Auxiliary lead (indicated as 'A') is placed in the wrong position and power is applied to the machine, the machine will protect itself and display an error message:

- "Err" "713 or 714" will be shown on the display.
- The control board and switch boards will blink out error 713 or 714 on their status leds.
- The weld output will be turned off and the control board will force itself into an idle state.
- The machine will need to have the misconnect condition removed before it will recover. Power must be removed prior to changing reconnect position.

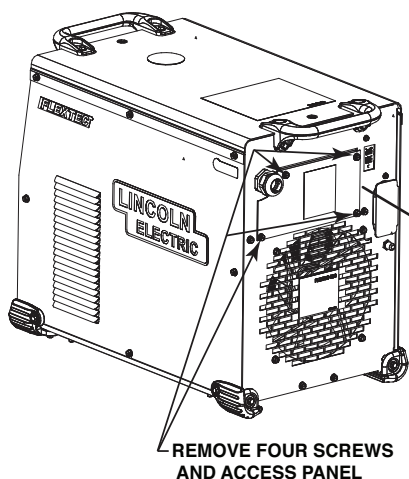

REMOVE FOUR SCREWS AND ACCESS PANEL

FIGURE A.1

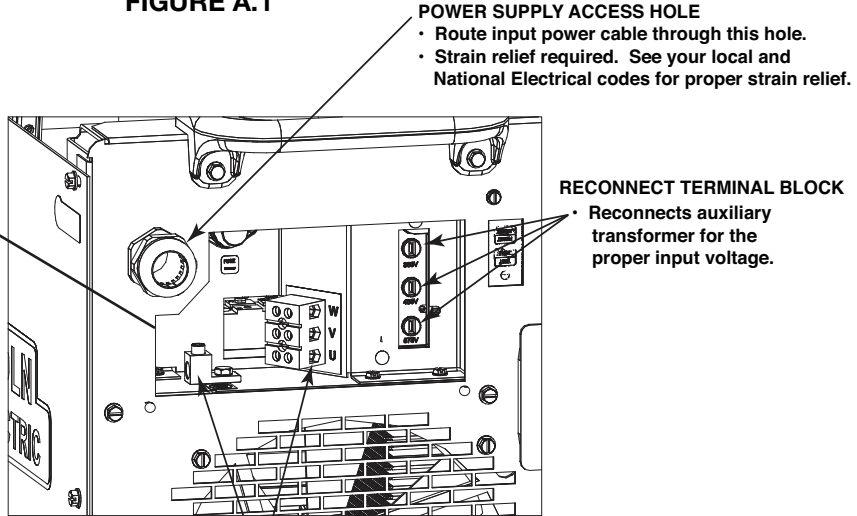

POWER SUPPLY ACCESS HOLE

- Route input power cable through this hole.
- Strain relief required. See your local and National Electrical codes for proper strain relief.

RECONNECT TERMINAL BLOCK

- Reconnects auxiliary transformer for the proper input voltage.

POWER SUPPLY TERMINAL BLOCK

- Line Cord/Cable attaches here.
- A ground terminal marked with the symbol shown is provided separate from this block for connecting the ground lead of the line cord. (See your local and national electrical codes for proper grounding methods.)

CABLE CONNECTIONS

See **FIGURE A.2** for locating **6-pin** and **14-pin** connectors on the front of the FLEXTEC™ 650.

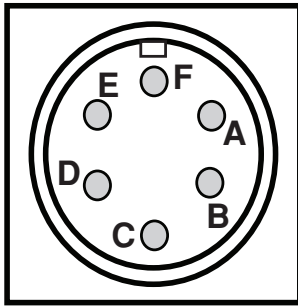

6-PIN REMOTE CONTROL CONNECTOR		
Function	Pin	Wiring
6-pin remote control connector for remote or hand/foot amptrol.	A	77 Remote potentiometer, 5K
	B	76 Remote potentiometer, wiper
	C	75 Remote potentiometer, common
	D	Trigger, common
	E	Trigger, input
	F	Ground

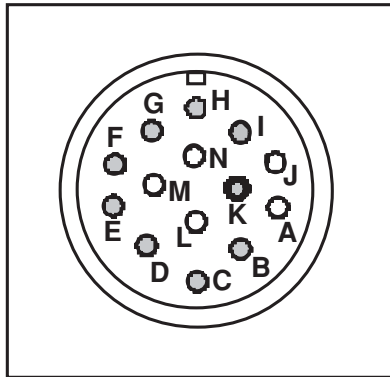

14-PIN CONNECTOR FOR WIRE FEEDER		
Function	Pin	Wiring
14 pin connector for wire feeder connectivity.	A	115 VAC
	B	Ground
	C	Trigger, Common
	D	Trigger input
	E	77 Remote potentiometer, 5K
	F	76 Remote potentiometer, wiper
	G	75 Remote potentiometer, common
	H	Voltage Sense (21)
	I	Motor (42 VAC)
	J	115 VAC
	K	Motor (42 VAC)
	L	
	M	
	N	

FIGURE A.2

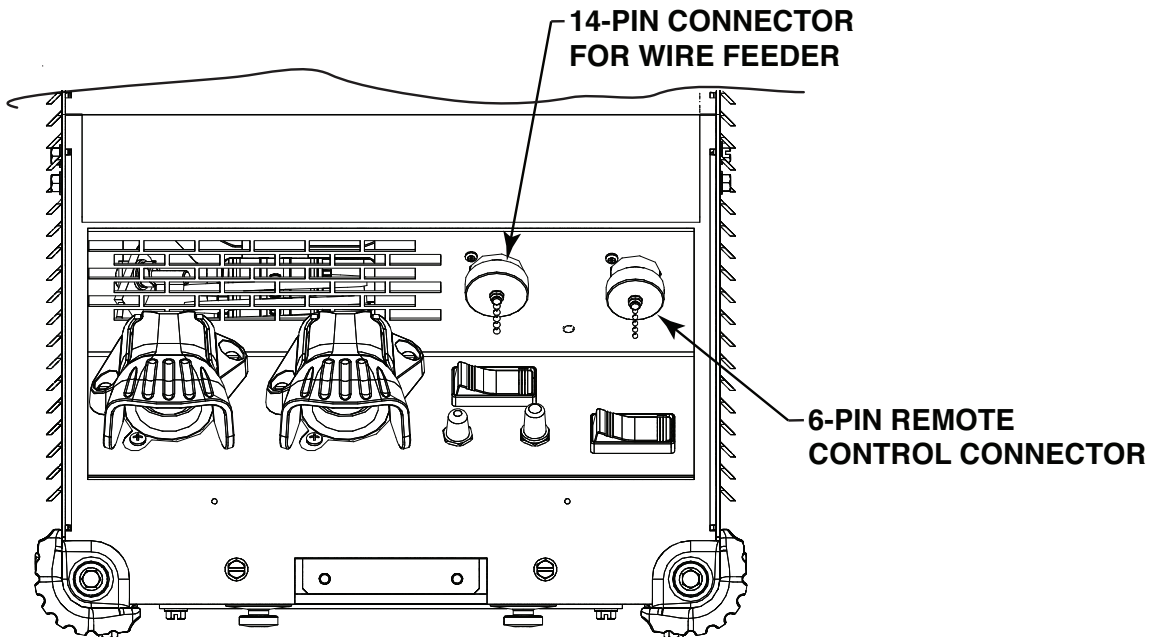

RECOMMENDED ELECTRODE AND WORK CABLE SIZES FOR ARC WELDING

General Guidelines

Connect the electrode and work cables between the appropriate output studs of the FLEXTEC™ 650 per the following guidelines:

- Most welding applications run with the electrode being positive (+). For those applications, connect the electrode cable between the wire drive feed plate and the positive (+) output stud on the power source. Connect a work lead from the negative (-) power source output stud to the work piece.
- When negative electrode polarity is required, such as in some Innershield applications, reverse the output connections at the power source (electrode cable to the negative (-) stud, and work cable to the positive (+) stud).

The following recommendations apply to all output polarities and weld modes:

- **Select the appropriate size cables per the “Output Cable Guidelines”** (See Table A.1). Excessive voltage drops caused by undersized welding cables and poor connections often result in unsatisfactory welding performance. Always use the largest welding cables (electrode and work) that are practical, and be sure all connections are clean and tight.

Note: Excessive heat in the weld circuit indicates undersized cables and/or bad connections.

- **Route all cables directly to the work and wire feeder, avoid excessive lengths and do not coil excess cable.** Route the electrode and work cables in close proximity to one another to minimize the loop area and therefore the inductance of the weld circuit.
- **Always weld in a direction away from the work (ground) connection.**

TABLE A.1

OUTPUT CABLE GUIDELINES

AMPERES	PERCENT DUTY CYCLE	CABLE SIZES FOR COMBINED LENGTHS OF ELECTRODE AND WORK CABLES (RUBBER COVERED COPPER - RATED 167°F or 75°C)**				
		0 to 50Ft. (0 to 15m)	50 to 100Ft. (15 to 30m)	100 to 150 Ft. (30 to 46m)	150 to 200 Ft. (46 to 61m)	200 to 250 Ft. (61 to 76m)
		200	60	2	2	2
200	100	2	2	2	1	1/0
250	30	3	3	2	1	1/0
250	40	2	2	1	1	1/0
250	60	1	1	1	1	1/0
250	100	1	1	1	1	1/0
300	60	1	1	1	1/0	2/0
300	100	2/0	2/0	2/0	2/0	3/0
350	40	1/0	1/0	2/0	2/0	3/0
400	60	2/0	2/0	2/0	3/0	4/0
400	100	3/0	3/0	3/0	3/0	4/0
500	60	2/0	2/0	3/0	3/0	4/0
600	60	3/0	3/0	3/0	4/0	2-3/0
600	80	2-1/0	2-1/0	2-1/0	2-2/0	2-3/0
600	100	2-1/0	2-1/0	2-1/0	2-2/0	2-3/0
650	60	3/0	3/0	4/0	2-2/0	2-3/0
650	80	2-1/0	2-1/0	2-1/0	2-2/0	2-3/0
700	100	2-2/0	2-2/0	2-3/0	2-3/0	2-4/0
800	80	3-1/0	3-1/0	3-1/0	2-3/0	2-4/0
800	100	2-3/0	2-3/0	2-3/0	2-3/0	2-4/0

** Tabled values are for operation at ambient temperatures of 104°F(40°C) and below. Applications above 104°F(40°C) may require cables larger than recommended, or cables rated higher than 167°F(75°C).

CONTROL CABLE CONNECTIONS

General Guidelines

Genuine Lincoln control cables should be used at all times (except where noted otherwise). Lincoln cables are specifically designed for the communication and power needs of the FLEXTEC™ 650. Most are designed to be connected end to end for ease of extension. Generally, it is recommended that the total length not exceed 100 feet (30.5 m). The use of non-standard cables, especially in lengths greater than 25 feet, can lead to communication problems (system shutdowns), poor motor acceleration (poor arc starting), and low wire driving force (wire feeding problems). Always use the shortest length of control cable possible, and DO NOT coil excess cable.

Regarding cable placement, best results will be obtained when control cables are routed separate from the weld cables. This

minimizes the possibility of interference between the high currents flowing through the weld cables, and the low level signals in the control cables.

PARALLELING

FLEXTEC™ 650 power sources may be paralleled for increased output requirements. No kit is required for paralleling of FLEXTEC™ 650 power sources. The FLEXTEC™ 650 can only be paralleled for constant current processes (mode switch must be in the SMAW position). Connect the power sources as shown, and set the output control of each power source to one half of the desired arc current. (See Figure A.3)

FIGURE A.3
PARALLELING DIAGRAM

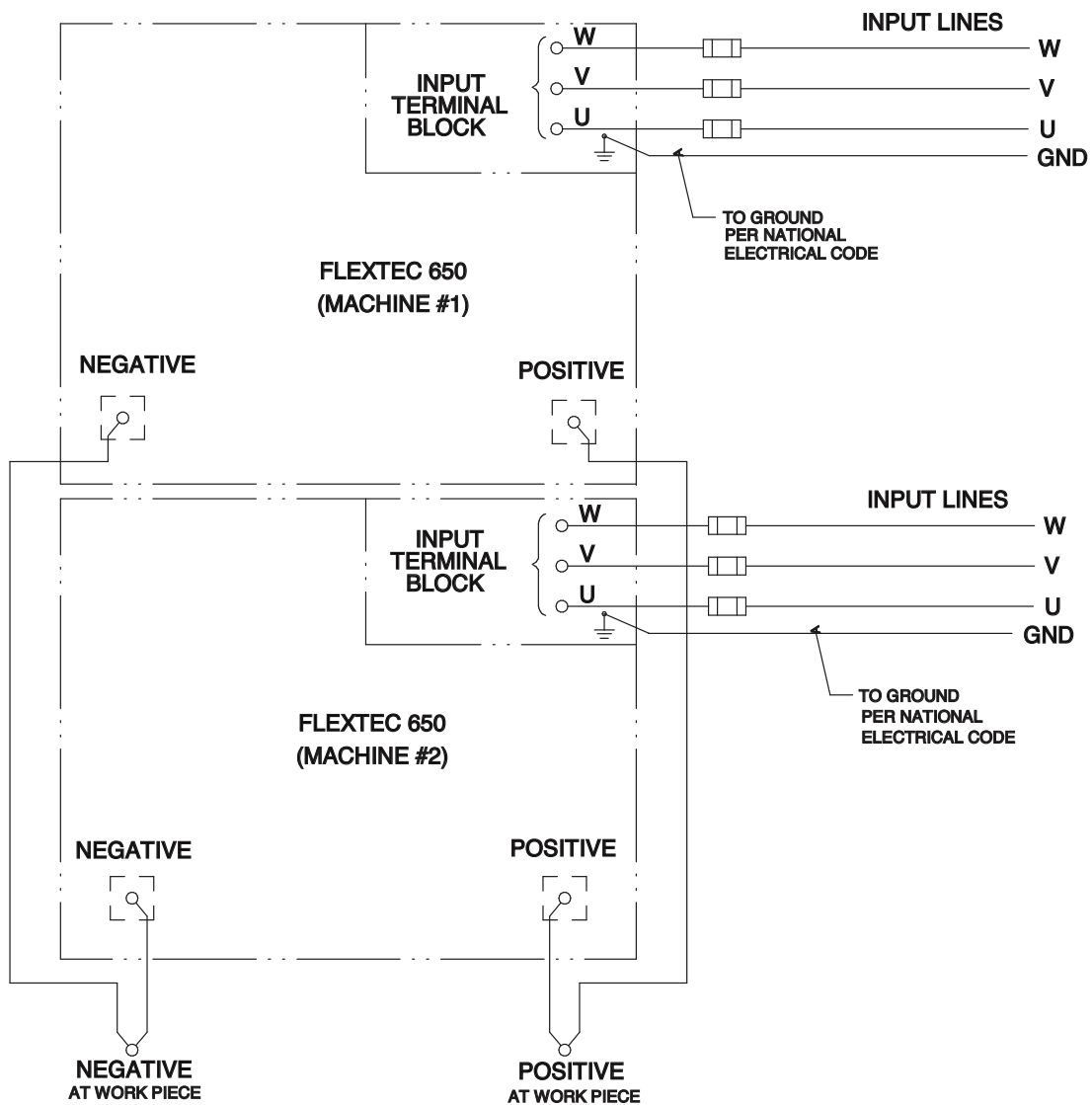

CONNECTING LF-72 AND LF-74 TO THE FLEXTEC™ 650

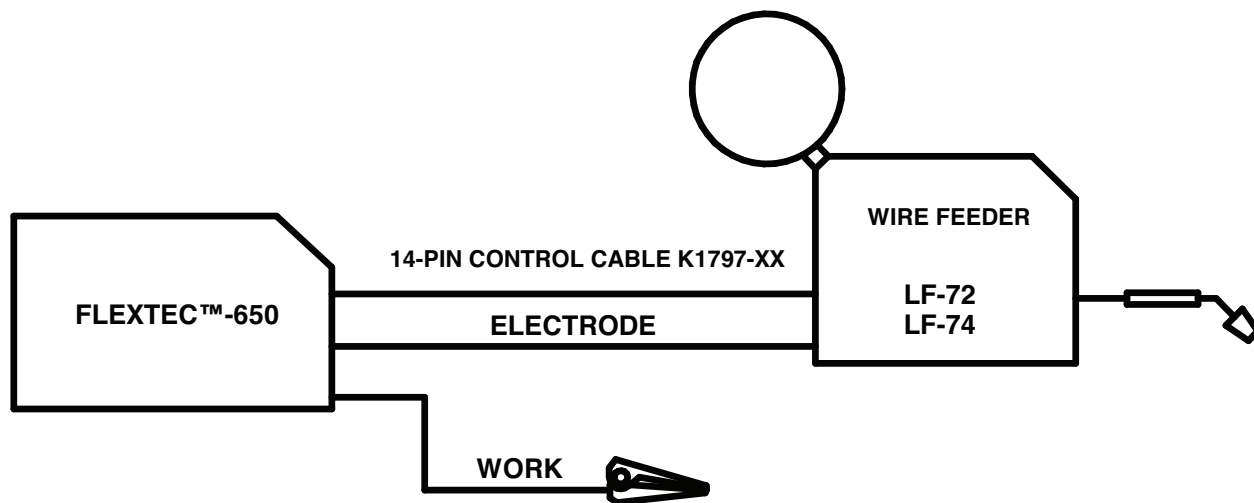

CONTROL SETTING	
WELD MODE	CV, CV-INNERSHIELD
WELD TERMINALS	OFF
REMOTE/LOCAL	LOCAL
	(REMOTE IF K2329-1 INSTALLED)
VOLTMETER POLARITY	PROCESS DEPENDENT

CONNECTING LN-10 AND DH-10 TO THE FLEXTEC™ 650

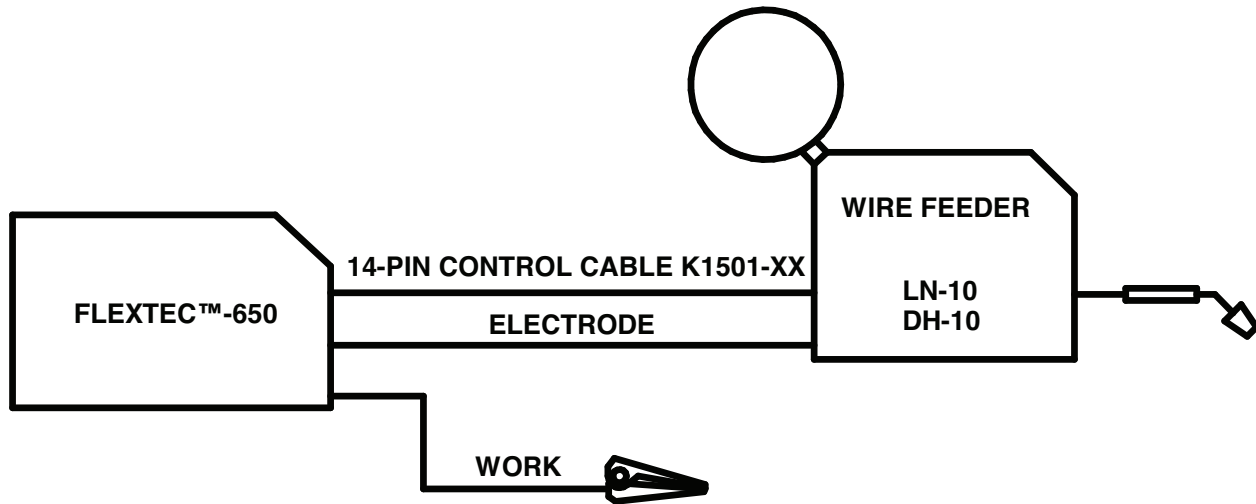

CONTROL SETTING	
WELD MODE	CV, CV-INNERSHIELD
WELD TERMINALS	OFF
REMOTE/LOCAL	REMOTE
VOLTMETER POLARITY	PROCESS DEPENDENT

LN-10, DH-10 CONTROL SWITCH SETUP

Initial set up of the LN-10, DH-10 control for the system components being used and for general operator preferences is done using a pair of 8-pole DIP switches located inside the LN-10, DH-10 control box.

Setting the DIP Switches

The DIP switches are each labeled with an “ON” arrow showing the on direction for each of the 8 individual switches in each DIP switch (S1 and S2). The functions of these switches are also labeled and set as described below:

Setup DIP Switch Access

- 1) Shut off the input power to the LN-10, DH-10 control by turning off the power at the welding power source it is connected to.
- 2) Remove the two screws on the top of the LN-10, DH-10 control box door and swing the door down to open.
- 3) Locate the two 8-pole DIP switches, near the top left corner of the LN-10, DH-10 Control P.C. board, labeled S1 and S2.
- 4) Switch settings are only programmed during input power-up restoration.

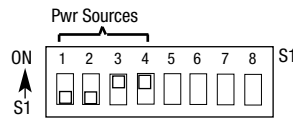

CONNECTING LN-25 PRO, LN-25 PIPE, ACTIV8 TO THE FLEXTEC™ 650

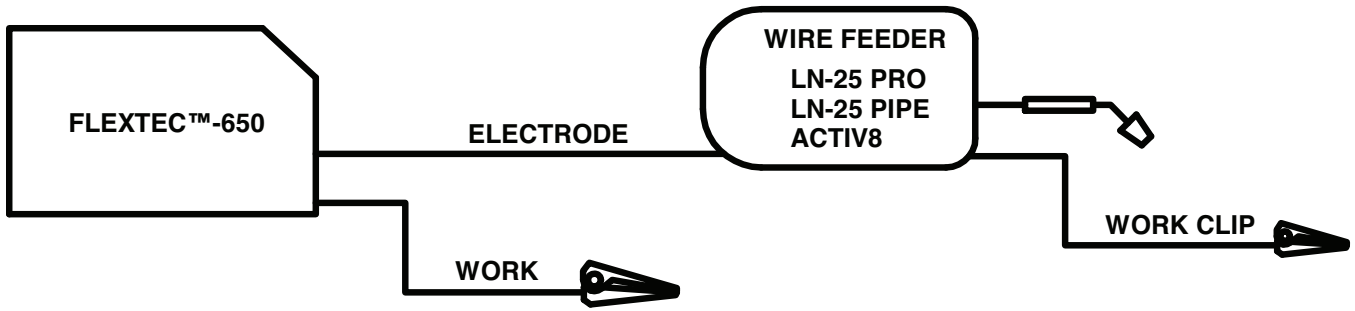

CONTROL SETTING	
WELD MODE	CV, CV-INNERSHIELD
WELD TERMINALS	ON
REMOTE/LOCAL	LOCAL
VOLTMETER POLARITY	PROCESS DEPENDENT

CONNECTING LN-25 PRO DUAL POWER TO THE FLEXTEC™ 650

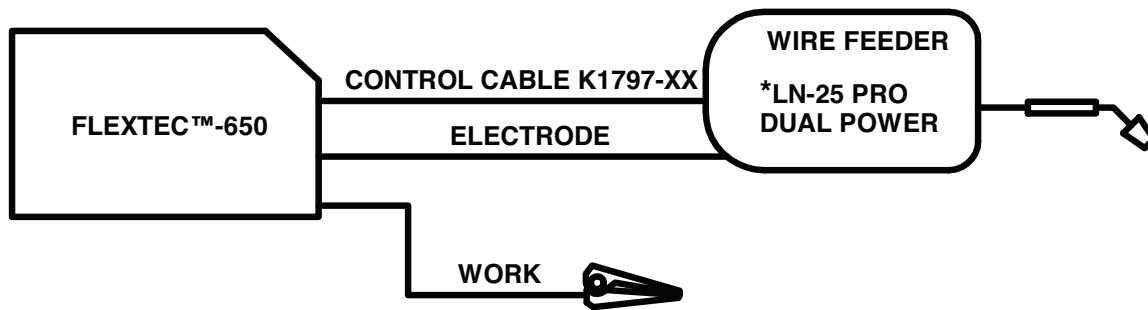

CONTROL SETTING	
WELD MODE	CV, CV-INNERSHIELD
WELD TERMINALS	OFF
REMOTE/LOCAL	REMOTE
VOLTMETER POLARITY	PROCESS DEPENDENT

*CONTROL CABLE SETUP SHOWN. REFER TO LN-25 PRO CONNECTION DIAGRAM IF SETTING UP "ACROSS-THE-ARC" FEEDER.

CONNECTING LN-7 TO THE FLEXTEC™ 650

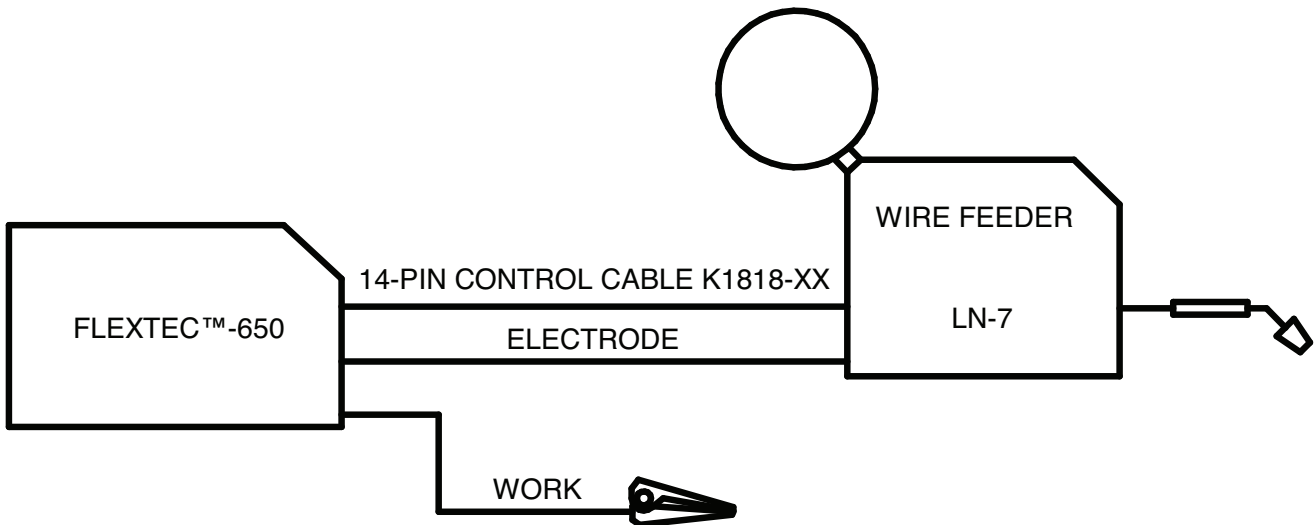

CONTROL SETTING	
WELD MODE	CV, CV-INNERSHIELD
WELD TERMINALS	OFF
REMOTE/LOCAL	LOCAL
VOLTMETER POLARITY	PROCESS DEPENDENT

CONNECTING LN-8 AND LN-9 TO THE FLEXTEC™ 650

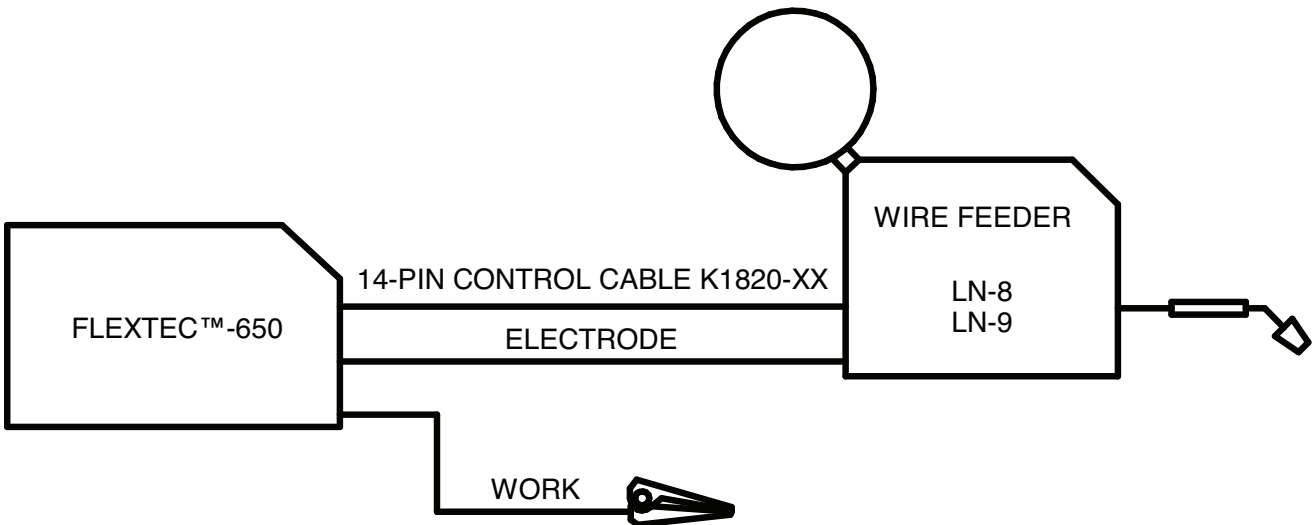

CONTROL SETTING	
WELD MODE	CV, CV-INNERSHIELD
WELD TERMINALS	OFF
REMOTE/LOCAL	REMOTE
VOLTMETER POLARITY	PROCESS DEPENDENT

CONNECTING NA-3, NA-5 TO THE FLEXTEC™ 650

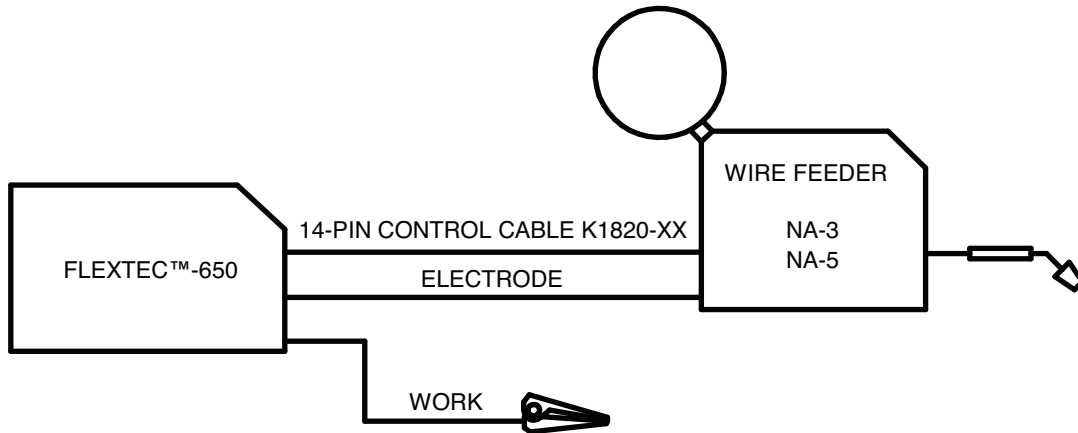

FOR NA-3, NA-4 WIRE FEEDERS ONLY:
 - MOVE JUMPER LEAD ON VARIABLE VOLTAGE BOARD TO "L" PIN.

FOR NA-5 WIRE FEEDER ONLY:
 - MOVE "BLUE" JUMPER LEAD ON VOLTAGE BOARD TO "AUTO" TERMINAL.

CONTROL SETTING	
WELD MODE	CV- SAW
WELD TERMINALS	OFF
REMOTE/LOCAL	REMOTE
VOLTMETER POLARITY	PROCESS DEPENDENT

CONNECTING LT-7 TO THE FLEXTEC™ 650

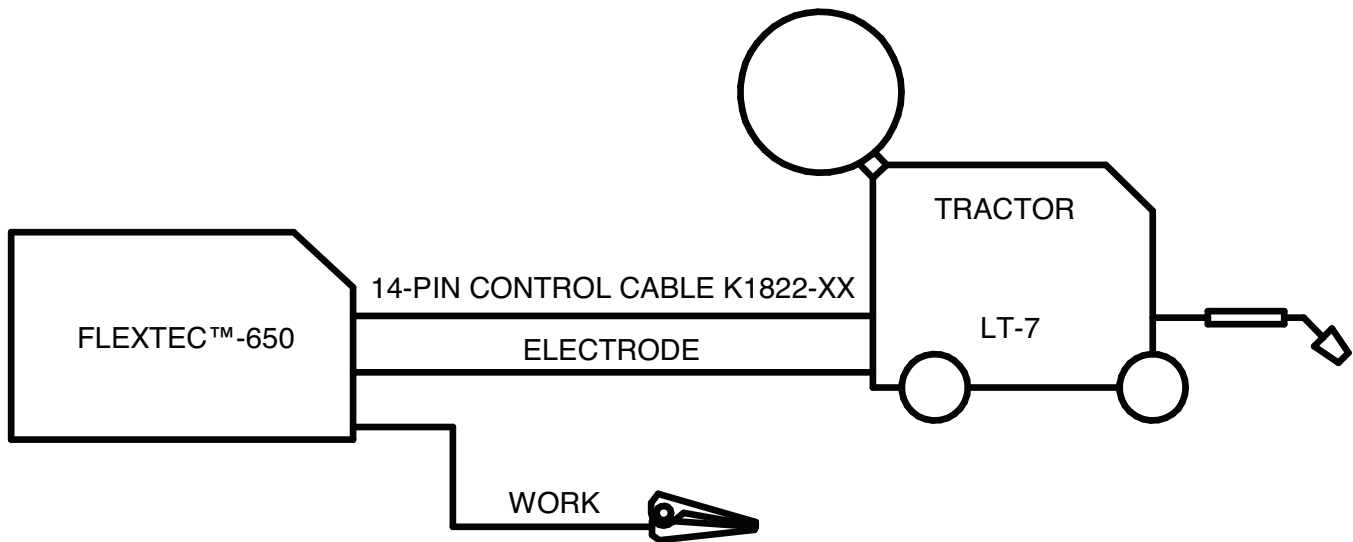

CONTROL SETTING	
WELD MODE	CV- SAW
WELD TERMINALS	OFF
REMOTE/LOCAL	REMOTE
VOLTMETER POLARITY	PROCESS DEPENDENT

SAFETY PRECAUTIONS

Read this entire section of operating instructions before operating the machine.

WARNING



ELECTRIC SHOCK can kill.

- Unless using cold feed feature, when feeding with gun trigger, the electrode and drive mechanism are always electrically energized and could remain energized several seconds after the welding ceases.
- Do not touch electrically live parts or electrodes with your skin or wet clothing.
- Insulate yourself from the work and ground.
- Always wear dry insulating gloves.



FUMES AND GASES can be dangerous.

- Keep your head out of fumes.
- Use ventilation or exhaust to remove fumes from breathing zone.

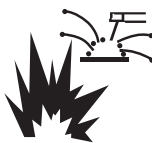

WELDING SPARKS can cause fire or explosion.

- Keep flammable material away.
- Do not weld on containers that have held combustibles.



ARC RAYS can burn.

- Wear eye, ear, and body protection.

Observe additional guidelines detailed in the beginning of this manual.

GRAPHIC SYMBOLS THAT APPEAR ON THIS MACHINE OR IN THIS MANUAL



INPUT POWER



ON



OFF



HIGH TEMPERATURE



CIRCUIT BREAKER



WIRE FEEDER



POSITIVE OUTPUT



NEGATIVE OUTPUT



3 PHASE INVERTER



INPUT POWER







THREE PHASE



DIRECT CURRENT

GRAPHIC SYMBOLS THAT APPEAR ON THIS MACHINE OR IN THIS MANUAL

U_r	REDUCED OPEN CIRCUIT VOLTAGE
U_0	OPEN CIRCUIT VOLTAGE
U_1	INPUT VOLTAGE
U_2	OUTPUT VOLTAGE
I_1	INPUT CURRENT
I_2	OUTPUT CURRENT
	PROTECTIVE GROUND
	WARNING or CAUTION
	Explosion
	Dangerous Voltage
	Shock Hazard

PRODUCT DESCRIPTION

The FLEXTEC™ 650 is a multi-process CC/CV DC inverter and is rated for 650 amps, 44 volts at a 100% duty cycle. The FLEXTEC™ 650 is intended for both factory and field operation. It comes in a compact, rugged case that is designed for portability and outdoor use with an IP23 environmental rating. The user interface of the FLEXTEC™ 650 is simple and intuitive. Weld modes are selected via a 5 position selector switch. Volts and Amps are displayed on an easy to view LED display, and the amps and volts are set via a large output control knob. A hot start and an arc control knob allow for finer tuning of the welding arc for the application.

The FLEXTEC™ 650 is designed for the North America and export markets and operates on 3 phase 380V, 460V, or 575V 50hz or 60hz power.

DUTY CYCLE

The FLEXTEC™ 650 is capable of welding at a 100% duty cycle (continuous welding) at 650 amps rated output. The 60% duty cycle rating is 750 amps (based off of a ten minute cycle – 6 minutes on time and 4 minutes off time). The maximum output of the machine is 815 amps.

The FLEXTEC™ 650 is also rated for Desert Duty, elevated temperature operation, in a 55°C ambient. The machine is de-rated for this application. (See Table in the Installation Section.

DESIGN FEATURES

- Severe Duty Design for outdoor use (IP23 rating)
- Passive Power Factor Correction – reliably gives 88% power factor for lower installation costs.
- 91% Efficiency rating – reduces electrical utility costs.
- Simple user interface - user interface is designed with the operator in mind. Getting setup for the weld is several clicks away and even the most novice welder can be confident he is setup properly.
- F.A.N. (fan as needed). Cooling fan runs when the output is energized and for a 5 minute cool down period after output is disabled
- Thermal protection by thermostats with Thermal Indicator LED.
- Reversible handles for ease of lifting and transporting
- Multiple options for lifting / transporting: Reversible handles; eyelet lifting bolts; and single forklift fork access
- Error Codes display on LED screen for ease of trouble shooting
- Electronic over current protection.
- Input voltage mis-connection protection.
- Utilizes digital signal processing and microprocessor control.
- VRD™ (Voltage Reduction Device)- Enable this function for reduced OCV in CC modes for added safety.

RECOMMENDED PROCESSES AND EQUIPMENT

RECOMMENDED PROCESSES

The FLEXTEC™ 650 is designed for CC-SMAW, CC-GTAW (lift tig), CV-GMAW, CV-FCAW-SS, CV-FCAW-GS and CV-SAW welding processes. CAG (arc gouging) is also supported.

PROCESS LIMITATIONS

The FLEXTEC™ 650 is suitable only for the processes listed.

Note: When used with K3091-1 Multi-Process Switch, the output is limited to 600A / 100% and 700A / 60%.

EQUIPMENT LIMITATIONS

Operating Temperature Range is -10° C to + 55° C.
Output De-rated at Temperatures above 40°C.

COMMON EQUIPMENT PACKAGES

Basic Package	
K3060-2	Flextec 650
K2327-5	LF-72 Bench Model
K2149-1	Work Cable
3100211	Harris Regulator and gas hose

Common Optional Kits	
K857	Remote Output Control (25 feet)
K857-1	Remote Output Control (100 feet)
K870	Foot Amptrol
K963-3	Hand Amptrol
K3091-1	Multi-Process Switch
K3129-1	CE Filter Kit

Compatible Wire Feeders	
All Models	LF-72
	LF-74
	LN-10
	DH-10
	LN-25 Pro
	LT-7 Tractor
	LN-8
	LN-9
	NA SERIES

CASE FRONT CONTROL DESCRIPTIONS

(See Figure B.1)

1. Power Switch: Controls input power to the Flextec 650.
2. Voltage Display Meter
3. Amperage Display Meter
4. Thermal LED: A yellow light that comes on when an over temperature situation occurs. Output is disabled until the machine cools down. When cool, the light goes out and output is enabled.
5. Weld Process Selector Switch: A rotary switch that toggles through the five available weld modes for the Flextec 650 – CC-SMAW; CC-GTAW; CV; CV-Innershield; CV-SAW.
6. Hot Start Control Dial
7. Output Control Dial: Sets the output current or voltage for the selected weld process.
8. Local/Remote Selector Toggle Switch: Sets the control of the output to local (output control knob) or remote (K857 hand amptrol or K870 foot amptrol).
9. Arc Force Control Dial
10. Weld Terminals On/Remote selector switch.
11. 14 pin wire feeder circular connector.
12. 115V or 42V wire feeder selector switch.
13. Circuit breaker reset buttons for the 14 pin wire feeder connector.
14. 6 pin remote circular connector.
15. Positive and negative welding output studs.
16. Wire Feeder Voltmeter Polarity Selection Switch.
17. VRD™ (Voltage Reduction Device) Indicator Lights

FIGURE B.1

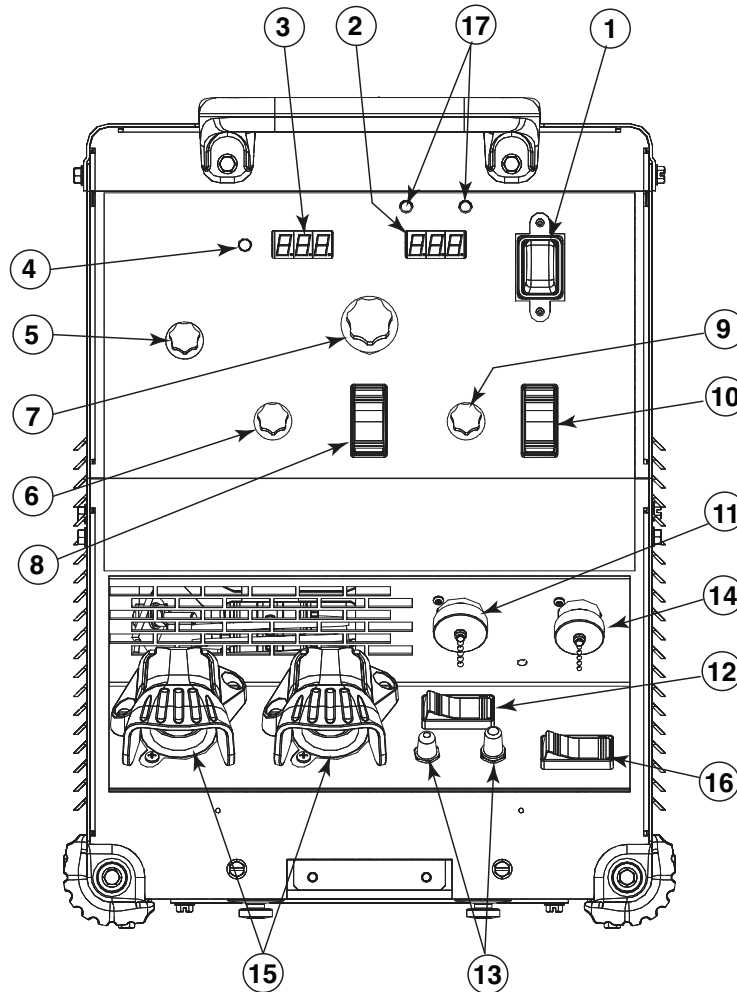

CASE BACK CONTROLS

(See Figure B.2)

1. Input Power Cord Access Hole.
2. Access Panel – Allows access for connecting input power and configuring the machine.
3. Input Power Reconnect – Configures the machine for the input supply voltage.
4. OPTION – GFCI protection for the 115V auxiliary output.
5. 115 volt, 15 amp auxiliary output duplex with protective environmental cover.
6. 15 Amp Circuit Breaker for the 115V auxiliary power.

FIGURE B.2

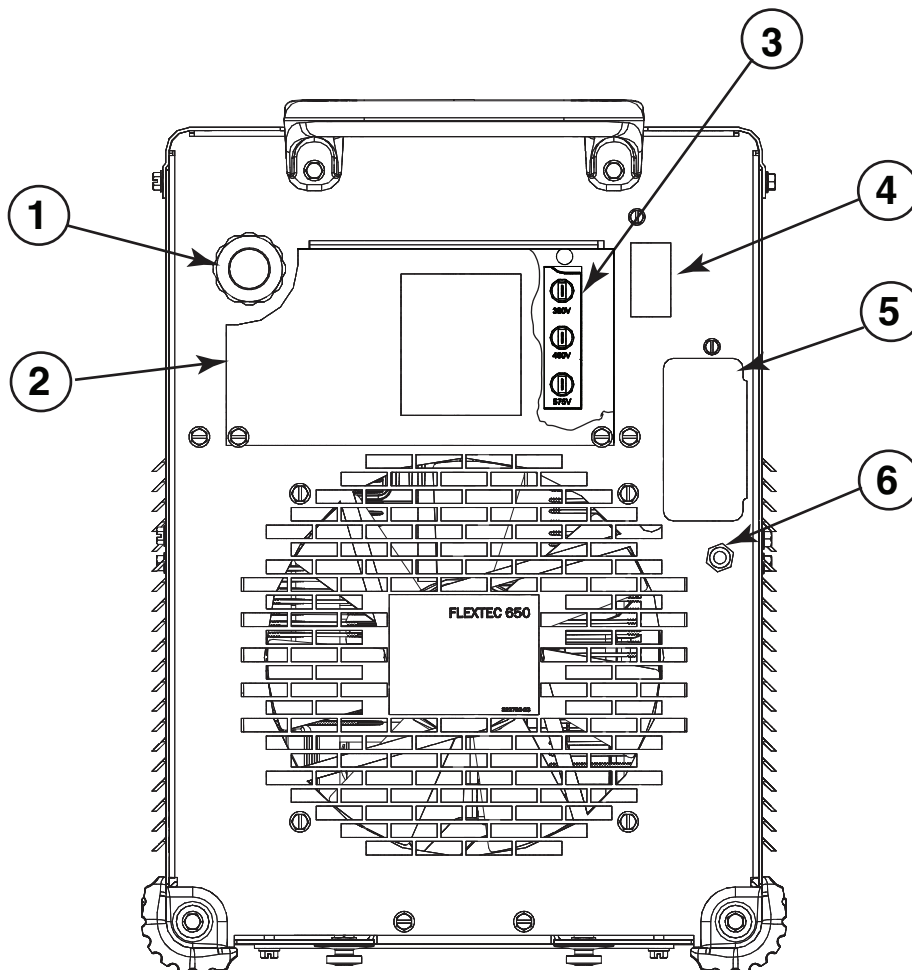

INTERNAL CONTROLS - ENABLING VRD™

To Enter **VRD™ Mode (VRD™ Enabled)**

Internal Controls Description

The Control PC Board has one bank of Dip Switches. As shipped from the factory VRD™ mode is disabled and the Dip Switches are all in the “off” position. For proper operation ensure that the “A” lead is connected properly according to the Auxiliary Reconnect Input Ranges table see **Technical Specification Section**.

a. For **380V input**: Switch #5 in the “ON” Position.

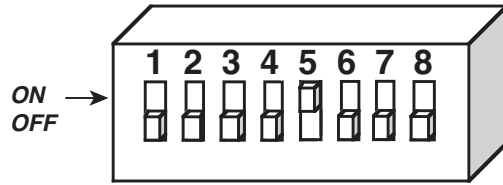

b. For **460V input**: Switch #6 in the “ON” Position.

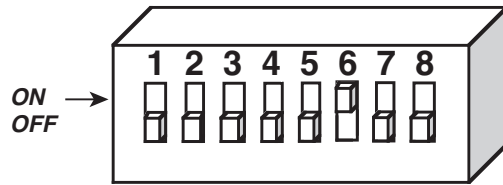

c. For **575V input**: Switch #5 and #6 in the “ON” Position

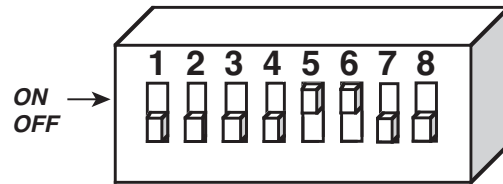
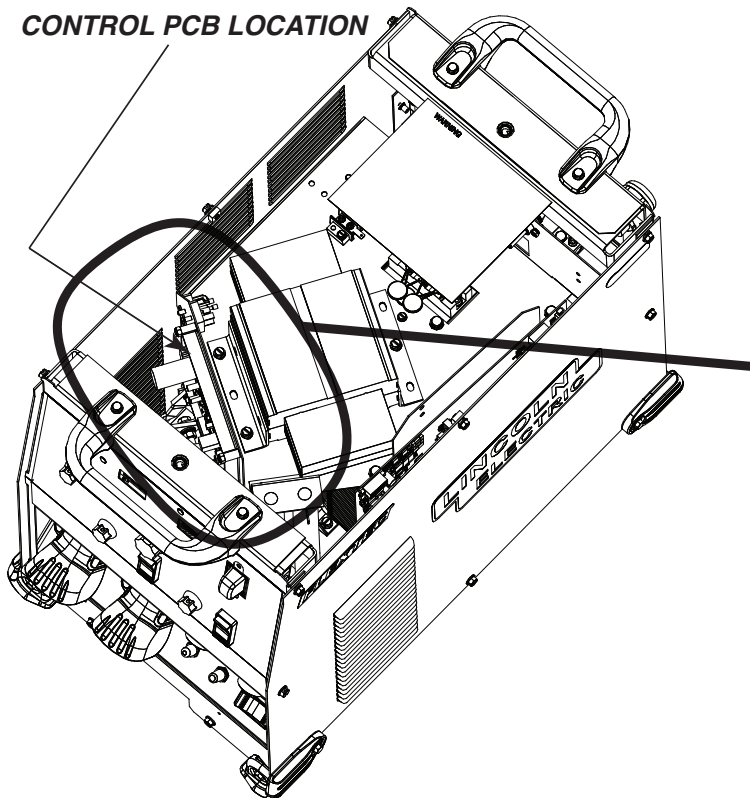
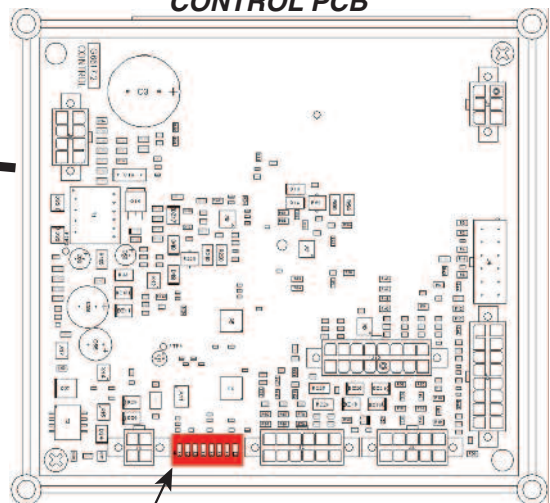

FIGURE B.3

CONTROL PCB LOCATION



CONTROL PCB



DIP SWITCH LOCATION

POWER-UP SEQUENCE

When power is applied to the FLEXTEC™ 650, the displays will illuminate and display the voltage and/or amperage settings.

COMMON WELDING PROCEDURES

WARNING

MAKING A WELD

The serviceability of a product or structure utilizing the welding programs is and must be the sole responsibility of the builder/user. Many variables beyond the control of The Lincoln Electric Company affect the results obtained in applying these programs. These variables include, but are not limited to, welding procedure, plate chemistry and temperature, weldment design, fabrication methods and service requirements. The available range of a welding program may not be suitable for all applications, and the build/user is and must be solely responsible for welding program selection.

The FLEXTEC™ 650 is a multi-process inverter welder. The **Weld Process Selector Switch** is used to set the desired weld mode. The FLEXTEC™ 650 has 5 selectable welding modes:

1. **SMAW** – This is a CC (constant current) weld mode used for the SMAW stick welding process.
2. **GTAW** – This is a CC (constant current) weld mode used for the GTAW TIG welding process.
3. **CV** – This is CV (constant voltage) weld mode used for welding the GMAW MIG welding process and the FCAW-GS flux cored gas shielded welding process.
4. **CV-Innershield** – This is a CV (constant voltage) weld mode used for welding the FCAW-SS, flux cored self shielded welding process.
5. **CV-SAW** – This is a CV (constant voltage) weld mode used for welding the SAW submerged arc welding process.

The FLEXTEC™ 650 is also capable of gouging. Gouging can be done in either the SMAW mode or the CV and CV-Innershield modes.

In addition to the weld process selector switch, a hot start control dial, output control dial and arc control dial are provided to setup and fine tune the welding procedure.

WELD CONTROLS AND DISPLAYS

Weld Process Selector Switch

5 Position switch used to select the welding process.

Hot Start Control Dial

- The Hot Start control regulates the starting current at arc initiation. Hot Start can be set to “0” and no additional current is added at arc start. Increasing from 0 to 10 will increase the additional current (relative to the preset current) that is added at arc initiation.

Arc Control Dial

- Full range selection of arc control from -10 to +10. In CV mode, this control is an inductance control. In stick mode, the control adjusts the arc force.

Output Control Dial

- Output control is conducted via a single turn potentiometer.
- Adjustment is indicated by the meters.
- When in REMOTE modes, this control sets the maximum welding current. Full depression of a foot or hand amptrol results in the preset level of current.

Voltage Display Meter

- Prior to CV operation (current flow), the meter displays desired preset voltage value (+/- .5V).
- Prior to STICK or TIG operation, the meter displays the Open Circuit Voltage of the Power Source or three dashes if the output has not been turned on.
- During welding, this meter displays actual average volts.
- After welding, the meter holds the actual voltage value for 5 seconds. The displays blink indicating that the machine is in the "Hold" period.
- Output adjustment while in the "Hold" period results in the "prior to operation" characteristics.

Amperage Display Meter

- Prior to STICK or TIG operation (current flow), the meter displays preset current value (either 2 amps or +/- 3% (e.g. 3 amps on 100), whichever is greater).
- Prior to CV operation, the meter displays three dashes indicating non-presettable AMPS.
- During welding, this meter displays actual average amps.
- After welding, the meter holds the actual current value for 5 seconds. The displays blink indicating that the machine is in the "Hold" period.
- Output adjustment while in the "Hold" period results in the "prior to operation" characteristics.

Weld Terminals On/Remote Toggle Switch

- This switch determines the trigger location.
- When set to the “ON” position, the weld terminals are at OCV (open circuit voltage) and ready to weld.
- When set to the “REMOTE” position, output is enabled through a remote trigger.

Control - Local/Remote Toggle Switch

- Set the switch to “LOCAL” to control output at the Flextec via the Output Control dial.
- Set the switch to “REMOTE” to control output via a remote device (K857 hand amptrol or K870 foot amptrol) connected to the 6-pin remote connector or a wire feeder connected to the 14-pin connector.

Wire Feeder Selector Switch

- This switch configures wire feeder supply voltage in the 14 pin connector to either 42 volt or 115 volt.
- If the switch is in the incorrect position for the attached wire feeder, there will be no power supplied to the wire feeder.

Wire Feeder Voltmeter Polarity Switch

- The switch provides a work connection for wire feeder voltmeters. Place the switch in the position of the electrode polarity indicated by the decal. The switch does not change the welding polarity.

Thermal Light

- This status light indicates when the power source has been driven into thermal overload. If the output terminals were “ON”, the output will be turned back on once the unit cools down to an acceptable temperature level. If the unit was operating in the “REMOTE” mode, the trigger will need to be opened before or after the thermal has cleared and closed after the machine has cooled down to an acceptable temperature to establish output.

VRD™ (VOLTAGE REDUCTION DEVICE) INDICATOR LIGHT

There are 2 indicator lights on the case front of the Flextec™ 650 above the Voltage LED Display to indicate the status of VRD™ operation. As shipped, the VRD™ function is disabled. VRD™ is enabled by setting dip switches on the Control P.C. board (See Internal Controls Figure B.3 in this **Operation Section**). When VRD™ is active:

- A green light indicates the OCV (open circuit voltage) is less than 35V peak.
- A red light indicates the OCV is at or above 35V peak.
- Both lights will illuminate for 5 seconds at power up.

For each weld mode, the VRD™ lights function as shown in Table B.1:

BASIC MODES OF OPERATION

SMAW

This weld mode is a constant current (CC) mode featuring continuous control from 15 – 815 amps. It is intended for the SMAW stick welding processes and arc gouging.

Output Control Local/Remote – When the control is set to “LOCAL” (no remote potentiometer/control plugged into the 6 pin or 14 pin connectors), the output is controlled through the Output Control Dial on the front of the FLEXTEC™ 650. Set this switch to “REMOTE” when an external potentiometer/control is connected.

- When a remote potentiometer is connected, the output control on the FLEXTEC™ 650 and the remote act as a master/slave configuration. Use the control dial on the FLEXTEC™ 650 to set the maximum welding current. The remote will control output from minimum to the pre-set maximum.

Hot Start - The Hot Start control regulates the starting current at arc initiation. Hot Start can be set to “0” and no additional current is added at arc start. Increasing from 0 to 10 will increase the additional current (relative to the preset current) that is added at arc initiation.

TABLE B.1

VRD™ Indicator Lights			
Mode	VRD™ “ON”	VRD™ “OFF”	
CC-SMAW	OCV	No lights are active	
CC-GTAW	While welding		
CV-GAS CV-Innershield CV-SAW	OCV		
			Red (OCV Not Reduced) Weld Terminals ‘ON’
			Red (OCV Not Reduced) Weld Terminals Remotely Controlled Gun Trigger Closed
			Green (NO OCV) Weld Terminals Remotely Controlled Gun Trigger Open
	While welding		
	Green or Red (depends on weld voltage)*		

* It is normal for the lights to alternate between colors while welding.

Arc Control – The Arc Control regulates the Arc Force to adjust the short circuit current. The minimum setting (-10) will produce a "soft" arc and will produce minimal spatter. The maximum setting (+10) will produce a "crisp" arc and will minimize electrode sticking.

Weld Terminals On/Remote – Set to "ON" and the machine is in the ready to weld state.

Voltage Display Meter – This display will display three dashed lines when the machine is in the idle state. This indicates that voltage is not settable in this weld mode. While output is enabled, the actual welding voltage will be displayed. After welding, the meter holds the actual voltage value for 5 seconds. Output adjustment while in the "hold" period results in the "prior to operation" characteristics stated above. The displays blink indicating that the machine is in the "hold" period.

GTAW

This weld mode is a constant current (CC) mode featuring continuous control from 10 – 815 amps. It is intended for the GTAW tig welding processes.

Hot Start - Hot start regulates the arc initiation current. A setting of +10 results in the most positive arc initiation.

Arc Control – This control is not used in the GTAW mode.

Weld Terminals On/Remote

- When set to the "ON" position, the weld terminals are at OCV (open circuit voltage) and ready to weld.
- When set to the "remote" position, output is enabled through a remote trigger.

Voltage Display Meter – This display will display three dashed lines when the machine is in the idle state.

This indicates that voltage is not settable in this weld mode. While output is enabled, the actual welding voltage will be displayed. After welding, the meter holds the actual voltage value for 5 seconds. Output adjustment while in the "hold" period results in the "prior to operation" characteristics stated above. The displays blink indicating that the machine is in the "hold" period.

Amperage Display Meter – This display will display the pre-set welding current when the machine is in the idle state. After welding, the meter holds the actual amperage value for 5 seconds. Output adjustment while in the "hold" period results in the "prior to operation" characteristics stated above. The displays blink indicating that the machine is in the "hold" period.

Output Control Local/Remote – When the control is set to "LOCAL" (no remote potentiometer/control plugged into the 6 pin or 14 pin connectors), the output is controlled through the Output Control Dial on the front of the FLEXTEC™ 650. Set this switch to "REMOTE" when an external potentiometer/control is connected.

- When a remote potentiometer is connected, the output control on the FLEXTEC™ 650 and the remote act as a master/slave configuration. Use the control dial on the FLEXTEC™ 650 to set the maximum welding current. The remote will control output from minimum to the pre-set maximum.

Output Control Dial

- When the Local/Remote is set to "LOCAL", this dial sets the welding amperage.
- When the Local/Remote is set to "REMOTE", this dial sets the maximum welding amperage. The remote potentiometer controls the amperage from minimum to this pre-set maximum.

CV-Gas

This weld mode is a constant voltage (CV) mode featuring continuous control from 10 to 45 volts. It is intended for the GMAW, FCAW-GS, MCAW welding processes and arc gouging.

Hot Start – Rotate from the "0" position to the "10" position to provide more energy during the start of a weld.

Arc Control – The Arc Control regulates pinch effect. At the minimum setting (-10), minimizes pinch and results in a soft arc. Low pinch settings are preferable for welding with gas mixes containing mostly inert gases. At the maximum setting (+10), maximizes pinch effect and results in a crisp arc. High pinch settings are preferable for welding FCAW and GMAW with CO₂.

Weld Terminals On/Remote

- When set to the "ON" position, the weld terminals are at OCV (open circuit voltage) and ready to weld. This selection is used for across the arc wire feeders.
- When set to the "REMOTE" position, output is enabled through a remote trigger.

Amperage Display Meter – This display will display three dashed lines when the machine is in the idle state. This indicates that amperage is not settable in this weld mode. While output is enabled, the actual welding amperage will be displayed. After welding, the meter holds the actual amperage value for 5 seconds. Output adjustment while in the "hold" period results in the "prior to operation" characteristics stated above.

The displays blink indicating that the machine is in the "hold" period.

Voltage Display Meter – This display will display the pre-set welding voltage when the machine is in the idle state. After welding, the meter holds the actual voltage value for 5 seconds. Output adjustment while in the "hold" period results in the "prior to operation" characteristics stated above. The displays blink indicating that the machine is in the "hold" period.

Output Control Local/Remote – When the control is set to "LOCAL" (no remote potentiometer/control plugged into the 6 pin or 14 pin connectors), the output is controlled through the Output Control Dial on the front of the FLEXTEC™ 650. Set this switch to "REMOTE" when an external potentiometer/control is connected.

Output Control Dial

- When the Local/Remote is set to "LOCAL", this dial sets the welding voltage.
- When the Local/Remote is set to "REMOTE", this dial is disabled.

CV-Innershield

This weld mode is a constant voltage (CV) mode featuring continuous control from 10 to 45 volts. It is intended for the FCAW-SS welding process and arc gouging.

Hot Start – Toggle from the “0” position to the “10” position to provide more energy during the start of a weld.

Arc Control – The Arc Control regulates pinch effect. At the minimum setting (-10), minimizes pinch and results in a soft arc. At the maximum setting (+10), maximizes pinch effect and results in a crisp arc.

Weld Terminals On/Remote

- When set to the “ON” position, the weld terminals are at OCV (open circuit voltage) and ready to weld. This selection is used for across the arc wire feeders.
- When set to the “REMOTE” position, output is enabled through a remote trigger.

Amperage Display Meter – This display will display three dashed lines when the machine is in the idle state. This indicates that amperage is not settable in this weld mode. While output is enabled, the actual welding amperage will be displayed. After welding, the meter holds the actual amperage value for 5 seconds. Output adjustment while in the “hold” period results in the “prior to operation” characteristics stated above. The displays blink indicating that the machine is in the “hold” period.

Voltage Display Meter – This display will display the pre-set welding voltage when the machine is in the idle state. After welding, the meter holds the actual voltage value for 5 seconds. Output adjustment while in the “hold” period results in the “prior to operation” characteristics stated above. The displays blink indicating that the machine is in the “hold” period.

Output Control Local/Remote – When the control is set to “LOCAL” (no remote potentiometer/control plugged into the 6 pin or 14 pin connectors), the output is controlled through the Output Control Dial on the front of the FLEXTEC™ 650. Set this switch to “REMOTE” when an external potentiometer/control is connected.

Output Control Dial

- When the Local/Remote is set to “LOCAL”, this dial sets the welding voltage.
- When the Local/Remote is set to “REMOTE”, this dial is disabled.

CV-SAW

This weld mode is a constant voltage (CV) mode featuring continuous control from 10 to 45 volts. It is intended for the CV-SAW submerged arc welding process.

Hot Start – Not used for this welding process.

Arc Control – Not used for this welding process .

Weld Terminals On/Remote

- When set to the “ON” position, the weld terminals are at OCV (open circuit voltage) and ready to weld. This selection is used for across the arc wire feeders.
- When set to the “REMOTE” position, output is enabled through a remote trigger.

Amperage Display Meter – This display will display three dashed lines when the machine is in the idle state. This indicates that amperage is not settable in this weld mode. While output is enabled, the actual welding amperage will be displayed. After welding, the meter holds the actual amperage value for 5 seconds. Output adjustment while in the “hold” period results in the “prior to operation” characteristics stated above. The displays blink indicating that the machine is in the “hold” period.

Voltage Display Meter – This display will display the pre-set welding voltage when the machine is in the idle state. After welding, the meter holds the actual voltage value for 5 seconds. Output adjustment while in the “hold” period results in the “prior to operation” characteristics stated above. The displays blink indicating that the machine is in the “hold” period.

Output Control Local/Remote – When the control is set to “LOCAL” (no remote potentiometer/control plugged into the 6 pin or 14 pin connectors), the output is controlled through the Output Control Dial on the front of the FLEXTEC™ 650. Set this switch to “REMOTE” when an external potentiometer/control is connected.

Output Control Dial

- When the Local/Remote is set to “LOCAL”, this dial sets the welding voltage.
- When the Local/Remote is set to “REMOTE”, this dial is disabled.

OPTIONS / ACCESSORIES

General Options

K2149-1 Work Lead Package.



K1842-10 10ft. Weld Power Cable (Lug to Lug).

K3091-1 Multi-Process Switch



Inverter and Wire Feeder

Cart Rear-wheeled cart with front casters and gas bottle platform. Convenient handles allow for easy cable storage. Small footprint fits through 30 in. (762 mm) door. Not intended for use with double head wire feeders. **Order K3059-2**



Fume Extracting Systems



Accessory Kit For stick welding. Includes 35 ft. (10.7 m) 2/0 electrode cable with lug, 30 ft. (9.1 m) 2/0 work cable with lugs, head shield, filter plate, cover plate, work clamp and electrode holder. 400 amp capacity. **Order K704**



Remote Output Control Consists of a control box with choice of two cable lengths. Permits remote adjustment of output.

Order K857 for 25 ft. (7.6 m)
Order K857-1 for 100 ft. (30 m)



TIG Options

Pro-Torch™ TIG Torches – PTA-9, PTA-17, PTA-26 – 2 piece power cord.

Foot Amptrol®

Provides 25 ft. (7.6 m) of remote current control for TIG welding. (6-pin plug connection).

Order K870



Hand Amptrol® - Provides 25 ft. (7.6 m) of remote current control for TIG welding. (6-pin plug connection).

Order K963-3



Arc Start Switch - May be used in place of the Foot or Hand Amptrol®. Comes with a 25 ft. (7.6m) cable. Attaches to the TIG torch for convenient finger control to start and stop the weld cycle at the current set on the machine.

Order K814



GFCI KIT - Order K3157-1

K3129-1 CE Filter Kit

Dual Cylinder Inverter and Wire Feeder Cart - Rear-wheeled cart with front casters and dual gas bottle platform. Convenient handles allow for easy cable storage. Small footprint fits through 30in. (762 mm) door. Can be used with dual head wire feeders.

Order K3059-3



SAFETY PRECAUTIONS

WARNING



- ELECTRIC SHOCK can kill.**
- **Only Qualified personnel should perform this maintenance.**
 - **Turn the input power OFF at the disconnect switch or fuse box before working on this equipment.**
-

See additional warning information throughout this Operator's Manual

VISUAL INSPECTION

Clean interior of machine with a low pressure air stream. Make a thorough inspection of all components. Look for signs of overheating, broken leads or other obvious problems. Many problems can be uncovered with a good visual inspection.

ROUTINE MAINTENANCE

VRD™ Functionality should be checked once per day or once per shift. VRD™ functionality can be verified by the indicator lights on the front of the power source. One of the lights will be illuminated at all times when VRD™ is enabled. No lights will be illuminated when VRD™ is disabled. VRD™ can be verified by cycling power as well. When VRD™ is enabled, the VRD™ indicator lights will illuminate for 5 seconds at power up and one light will remain illuminated.

1. Every 6 months or so the machine should be cleaned with a low pressure airstream. Keeping the machine clean will result in cooler operation and higher reliability. Be sure to clean these areas:
 - All printed circuit boards
 - Power switch
 - Main transformer
 - Heatsink fins
 - Input rectifier
 - Auxiliary transformer
 - Reconnect switch area
 - Fan (blow air through the rear louvers)
2. Examine the sheet metal case for dents or breakage. Repair the case as required. Keep the case in good condition to insure that high voltage parts are protected and correct spacings are maintained. All external sheet metal screws must be in place to insure case strength and electrical ground continuity.

PERIODIC MAINTENANCE

Thermal Protection

Thermostats protect the machine from excessive operating temperatures. Excessive temperatures may be caused by a lack of cooling air or operating the machine beyond the duty cycle and output rating. If excessive operating temperature should occur, the thermostat will prevent output voltage or current. The meter will remain energized during this time. Thermostats are self-resetting once the machine cools sufficiently. If the thermostat shutdown was caused by excessive output or duty cycle and the fan is operating normally, the Power Switch may be left on and the reset should occur within a 15 minute period.

HOW TO USE TROUBLESHOOTING GUIDE

WARNING

Service and Repair should only be performed by Lincoln Electric Factory Trained Personnel. Unauthorized repairs performed on this equipment may result in danger to the technician and machine operator and will invalidate your factory warranty. For your safety and to avoid Electrical Shock, please observe all safety notes and precautions detailed throughout this manual.

This Troubleshooting Guide is provided to help you locate and repair possible machine malfunctions. Simply follow the three-step procedure listed below.

Step 1. LOCATE PROBLEM (SYMPTOM).

Look under the column labeled “PROBLEM (SYMPTOMS)”. This column describes possible symptoms that the machine may exhibit. Find the listing that best describes the symptom that the machine is exhibiting.

Step 2. POSSIBLE CAUSE.

The second column labeled “POSSIBLE CAUSE” lists the obvious external possibilities that may contribute to the machine symptom.

Step 3. RECOMMENDED COURSE OF ACTION

This column provides a course of action for the Possible Cause, generally it states to contact your local Lincoln Authorized Field Service Facility.

If you do not understand or are unable to perform the Recommended Course of Action safely, contact your local Lincoln Authorized Field Service Facility.

CAUTION

If for any reason you do not understand the test procedures or are unable to perform the tests/repairs safely, contact your **Local Lincoln Authorized Field Service Facility** for technical troubleshooting assistance before you proceed.

Observe all Safety Guidelines detailed throughout this manual

PROBLEMS (SYMPTOMS)	POSSIBLE CAUSE	RECOMMENDED COURSE OF ACTION
Major physical or electrical damage is evident when the sheet metal covers are removed.	1. Contact your local authorized Lincoln Electric Field Service facility for technical assistance.	1.If all recommended possible areas of misadjustment have been checked and the problem persists, Contact your local Lincoln Authorized Field Service Facility.
Machine won't weld, can't get any output.	1. If the displays show an Err ### see the fault section for corrective action. 2 If the thermal LED is lit refer to the thermal section. 3 If the output terminals are in remote control switch to "ON" and check for output voltage. If output voltage is now present check for correct remote control connection and operation.	
Thermal LED is lit.	1. Check for proper fan operation. <ul style="list-style-type: none"> • Check for material blocking intake or exhaust louvers. • Blow air in the rear louvers to clear dirt from the fan. Note: The Fan As Needed circuitry automatically shuts off the fan 5 minutes after welding has stopped. 2. Welding output ratings may have been exceeded. Allow the machine to cool down and reset.	
Wire feeder won't work. Apparently no power to wire feeder	1. Check the 115/42V wire feeder switch (located on the case front) to make sure it is properly set for the input voltage requirement of the wire feeder. 2. Check circuit breakers by the wire feeder receptacles on the front of the machine. Reset if required. 3. Check the control cable between the power source and the wire feeder for continuity.	

⚠ CAUTION

If for any reason you do not understand the test procedures or are unable to perform the tests/repairs safely, contact your **Local Lincoln Authorized Field Service Facility** for technical troubleshooting assistance before you proceed.

Observe all Safety Guidelines detailed throughout this manual

USING THE STATUS LED TO TROUBLESHOOT SYSTEM PROBLEMS

Errors are displayed on the amperage and voltage display meters. In addition, there are status lights on the control pc board and the switch pc board that contain error sequences.

Included in this section is information about the fault codes indicated on the status lights and some basic troubleshooting charts for both machine and weld performance.

The status lights on the main control board and the switch pc board are dual-color LED's. Normal operation for each is steady green.

FLEXTEC™ 650 Fault Codes			
Error Code#	Description	Possible Cause	Corrective Action
21	Device that controls sequence of the welding operation halted due to an error.		Weld Terminals Remote: Re-trigger to recover from error. Weld Terminals Local: Toggle Remote/Local Switch to recover from error.
31	Primary Over Current.	Check the input power (voltage and frequency). Verify the primary reconnect is properly configured for the input voltage.	Machine needs to be turned off and back on to reset.
36	Thermal Fault	Machine shut off output due to elevated internal temperatures.	1. Check for material blocking intake or exhaust louvers. <ul style="list-style-type: none"> • Blow air in the rear louvers to clear dirt from the fan. Note: The Fan As Needed circuitry automatically shuts off the fan 5 minutes after welding has stopped. 2. Welding output ratings may have been exceeded. Allow the machine to cool down and reset.
45	VRD™ Voltage limit exceeded.	During OCV, the voltage exceeded allowable VRD™ levels. <ul style="list-style-type: none"> • Verify dip switch settings are correct for the input voltage. 	Machine needs to be turned off and back on to reset.
712	Communication Fault	CAN communication between the control pcb and switch pcb has been interrupted.	Inspect harness for damage / loose connections.

⚠ CAUTION

If for any reason you do not understand the test procedures or are unable to perform the tests/repairs safely, contact your **Local Lincoln Authorized Field Service Facility** for technical troubleshooting assistance before you proceed.

Observe all Safety Guidelines detailed throughout this manual

FLEXTEC™ 650 Fault Codes			
Error Code#	Description	Possible Cause	Corrective Action
713	Input Power Mismatch. Supply Voltage is too high.	Occurs upon power up when the supply voltage to the switch pcb exceeded acceptable levels.	Verify the primary reconnect is properly configured for the input voltage. Machine needs to be turned off and back on to reset.
714	Input Power Mismatch. Supply Voltage is too low.	Occurs upon power up when the supply voltage to the switch pcb is below acceptable levels.	Verify the primary reconnect is properly configured for the input voltage. Machine needs to be turned off and back on to reset.
715	Under Voltage Lockout.	The supply voltage to the switch pcb is below acceptable levels	Machine needs to be turned off and back on to reset.
719	Switch PCB Error.		Machine needs to be turned off and back on to reset.
If any of these conditions persist contact an authorized Lincoln Field Service Shop.			

⚠ CAUTION

If for any reason you do not understand the test procedures or are unable to perform the tests/repairs safely, contact your **Local Lincoln Authorized Field Service Facility** for technical troubleshooting assistance before you proceed.

Flextec 650 Wiring Diagram (Code 11936)

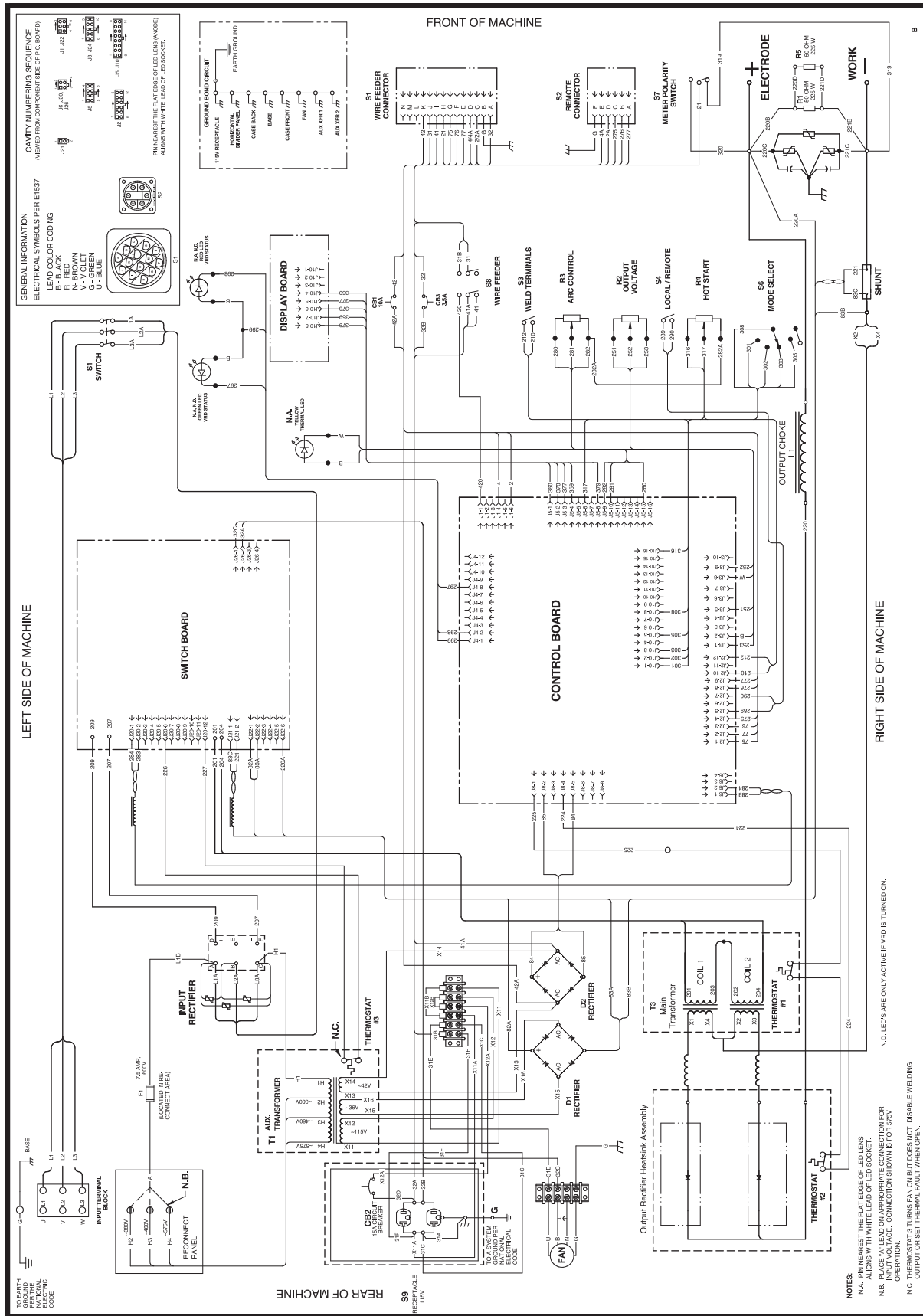

NOTE: This diagram is for reference only. It may not be accurate for all machines covered by this manual. The specific diagram for a particular code is pasted inside the machine on one of the enclosure panels. If the diagram is illegible, write to the Service Department for a replacement. Give the equipment code number.

Flextec 650 Wiring Diagram (Code 12340)

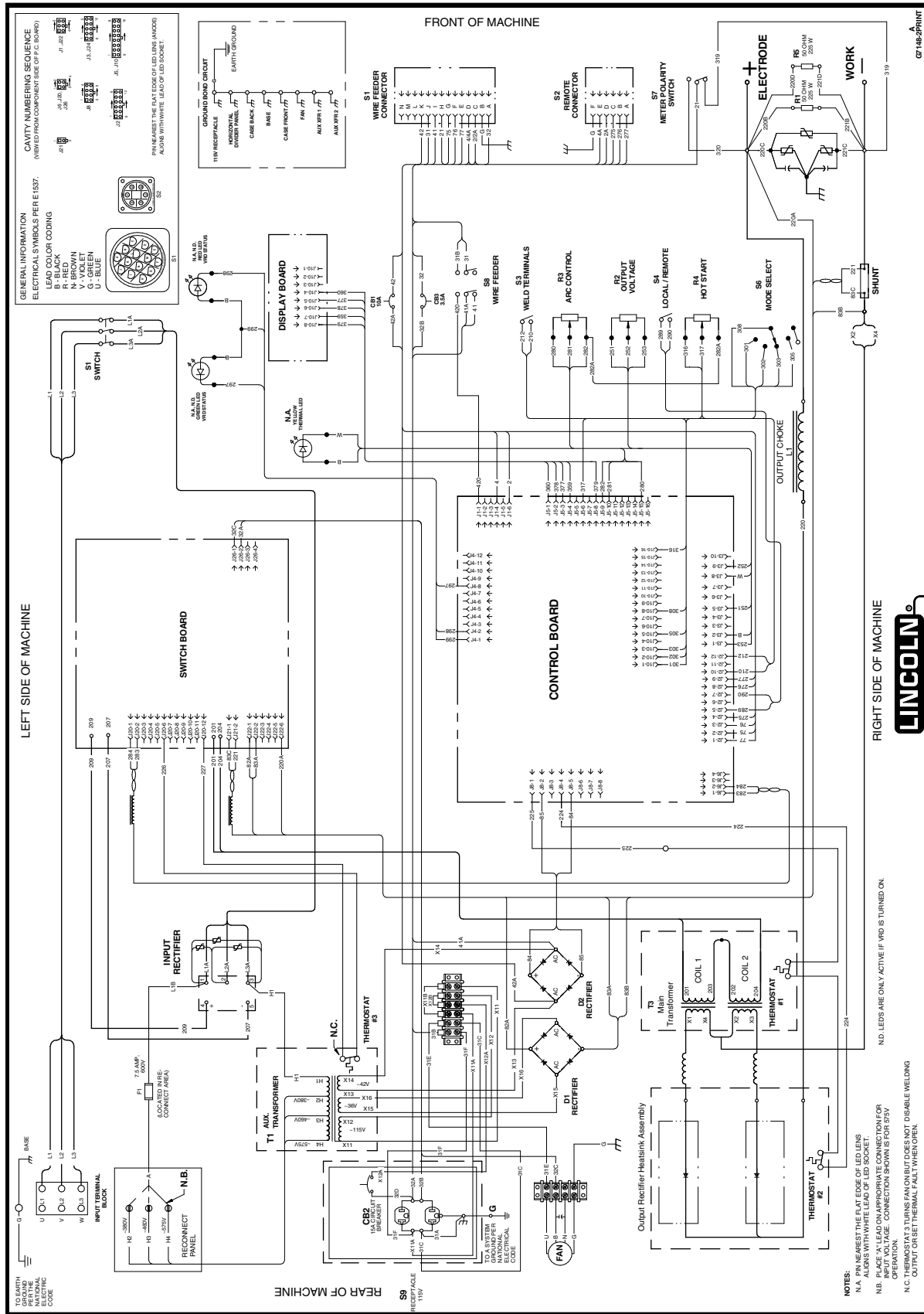

NOTE: This diagram is for reference only. It may not be accurate for all machines covered by this manual. The specific diagram for a particular code is pasted inside the machine on one of the enclosure panels. If the diagram is illegible, write to the Service Department for a replacement. Give the equipment code number.

Flextec 650 Wiring Diagram (Code 12621)

Hold for G7148-5

NOTE: This diagram is for reference only. It may not be accurate for all machines covered by this manual. The specific diagram for a particular code is pasted inside the machine on one of the enclosure panels. If the diagram is illegible, write to the Service Department for a replacement. Give the equipment code number.

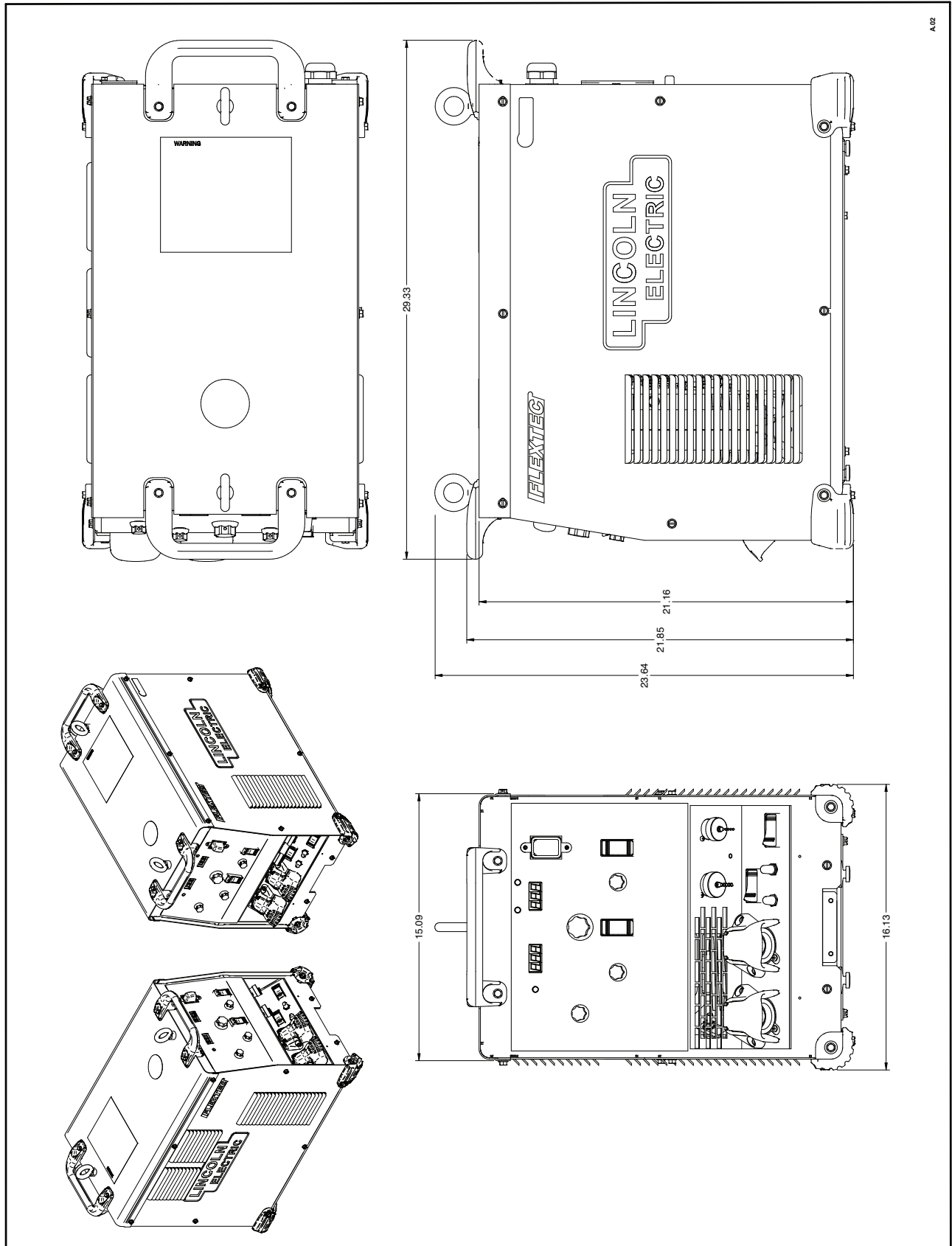

A102

L16096

			
WARNING	<ul style="list-style-type: none"> ● Do not touch electrically live parts or electrode with skin or wet clothing. ● Insulate yourself from work and ground. 	<ul style="list-style-type: none"> ● Keep flammable materials away. 	<ul style="list-style-type: none"> ● Wear eye, ear and body protection.
Spanish AVISO DE PRECAUCION	<ul style="list-style-type: none"> ● No toque las partes o los electrodos bajo carga con la piel o ropa mojada. ● Aíslese del trabajo y de la tierra. 	<ul style="list-style-type: none"> ● Mantenga el material combustible fuera del área de trabajo. 	<ul style="list-style-type: none"> ● Protéjase los ojos, los oídos y el cuerpo.
French ATTENTION	<ul style="list-style-type: none"> ● Ne laissez ni la peau ni des vêtements mouillés entrer en contact avec des pièces sous tension. ● Isolez-vous du travail et de la terre. 	<ul style="list-style-type: none"> ● Gardez à l'écart de tout matériel inflammable. 	<ul style="list-style-type: none"> ● Protégez vos yeux, vos oreilles et votre corps.
German WARNUNG	<ul style="list-style-type: none"> ● Berühren Sie keine stromführenden Teile oder Elektroden mit Ihrem Körper oder feuchter Kleidung! ● Isolieren Sie sich von den Elektroden und dem Erdboden! 	<ul style="list-style-type: none"> ● Entfernen Sie brennbares Material! 	<ul style="list-style-type: none"> ● Tragen Sie Augen-, Ohren- und Körperschutz!
Portuguese ATENÇÃO	<ul style="list-style-type: none"> ● Não toque partes elétricas e electrodos com a pele ou roupa molhada. ● Isole-se da peça e terra. 	<ul style="list-style-type: none"> ● Mantenha inflamáveis bem guardados. 	<ul style="list-style-type: none"> ● Use proteção para a vista, ouvido e corpo.
Japanese 注意事項	<ul style="list-style-type: none"> ● 通電中の電気部品、又は溶材にヒフやぬれた布で触れないこと。 ● 施工物やアースから身体が絶縁されている様にして下さい。 	<ul style="list-style-type: none"> ● 燃えやすいものの側での溶接作業は絶対にしてはなりません。 	<ul style="list-style-type: none"> ● 目、耳及び身体に保護具をして下さい。
Chinese 警告	<ul style="list-style-type: none"> ● 皮肤或湿衣物切勿接触带电部件及焊条。 ● 使你自已与地面和工件绝缘。 	<ul style="list-style-type: none"> ● 把一切易燃物品移离工作场所。 	<ul style="list-style-type: none"> ● 佩戴眼、耳及身体劳动保护用具。
Korean 위험	<ul style="list-style-type: none"> ● 전도체나 용접봉을 젖은 헝겍 또는 피부로 절대 접촉치 마십시오. ● 모재와 접지를 접촉치 마십시오. 	<ul style="list-style-type: none"> ● 인화성 물질을 접근시키지 마십시오. 	<ul style="list-style-type: none"> ● 눈, 귀와 몸에 보호장구를 착용하십시오.
Arabic تحذير	<ul style="list-style-type: none"> ● لا تلمس الاجزاء التي يسري فيها التيار الكهربائي أو الألكترود بجند الجسم أو بالملابس المبللة بالماء. ● ضع عازلا على جسمك خلال العمل. 	<ul style="list-style-type: none"> ● ضع المواد القابلة للاشتعال في مكان بعيد. 	<ul style="list-style-type: none"> ● ضع أدوات وملابس واقية على عينيك وأذنيك وجسمك.

READ AND UNDERSTAND THE MANUFACTURER'S INSTRUCTION FOR THIS EQUIPMENT AND THE CONSUMABLES TO BE USED AND FOLLOW YOUR EMPLOYER'S SAFETY PRACTICES.

SE RECOMIENDA LEER Y ENTENDER LAS INSTRUCCIONES DEL FABRICANTE PARA EL USO DE ESTE EQUIPO Y LOS CONSUMIBLES QUE VA A UTILIZAR, SIGA LAS MEDIDAS DE SEGURIDAD DE SU SUPERVISOR.

LISEZ ET COMPRENEZ LES INSTRUCTIONS DU FABRICANT EN CE QUI REGARDE CET EQUIPMENT ET LES PRODUITS A ETRE EMPLOYES ET SUIVEZ LES PROCEDURES DE SECURITE DE VOTRE EMPLOYEUR.

LESEN SIE UND BEFOLGEN SIE DIE BETRIEBSANLEITUNG DER ANLAGE UND DEN ELEKTRODENEINSATZ DES HERSTELLERS. DIE UNFALLVERHÜTUNGSVORSCHRIFTEN DES ARBEITGEBERS SIND EBENFALLS ZU BEACHTEN.

			
<ul style="list-style-type: none"> ● Keep your head out of fumes. ● Use ventilation or exhaust to remove fumes from breathing zone. 	<ul style="list-style-type: none"> ● Turn power off before servicing. 	<ul style="list-style-type: none"> ● Do not operate with panel open or guards off. 	WARNING
<ul style="list-style-type: none"> ● Los humos fuera de la zona de respiración. ● Mantenga la cabeza fuera de los humos. Utilice ventilación o aspiración para gases. 	<ul style="list-style-type: none"> ● Desconectar el cable de alimentación de poder de la máquina antes de iniciar cualquier servicio. 	<ul style="list-style-type: none"> ● No operar con panel abierto o guardas quitadas. 	Spanish AVISO DE PRECAUCION
<ul style="list-style-type: none"> ● Gardez la tête à l'écart des fumées. ● Utilisez un ventilateur ou un aspirateur pour ôter les fumées des zones de travail. 	<ul style="list-style-type: none"> ● Débranchez le courant avant l'entretien. 	<ul style="list-style-type: none"> ● N'opérez pas avec les panneaux ouverts ou avec les dispositifs de protection enlevés. 	French ATTENTION
<ul style="list-style-type: none"> ● Vermeiden Sie das Einatmen von Schweißrauch! ● Sorgen Sie für gute Be- und Entlüftung des Arbeitsplatzes! 	<ul style="list-style-type: none"> ● Strom vor Wartungsarbeiten abschalten! (Netzstrom völlig öffnen; Maschine anhalten!) 	<ul style="list-style-type: none"> ● Anlage nie ohne Schutzgehäuse oder Innenschutzverkleidung in Betrieb setzen! 	German WARNUNG
<ul style="list-style-type: none"> ● Mantenha seu rosto da fumaça. ● Use ventilação e exaustão para remover fumo da zona respiratória. 	<ul style="list-style-type: none"> ● Não opere com as tampas removidas. ● Desligue a corrente antes de fazer serviço. ● Não toque as partes elétricas nuas. 	<ul style="list-style-type: none"> ● Mantenha-se afastado das partes moventes. ● Não opere com os painéis abertos ou guardas removidas. 	Portuguese ATENÇÃO
<ul style="list-style-type: none"> ● ヒュームから頭を離すようにして下さい。 ● 換気や排煙に十分留意して下さい。 	<ul style="list-style-type: none"> ● メンテナンス・サービスに取りかかる際には、まず電源スイッチを必ず切ってください。 	<ul style="list-style-type: none"> ● パネルやカバーを取り外したままで機械操作をしないで下さい。 	Japanese 注意事項
<ul style="list-style-type: none"> ● 頭部遠離煙霧。 ● 在呼吸區使用通風或排風器除煙。 	<ul style="list-style-type: none"> ● 維修前切斷電源。 	<ul style="list-style-type: none"> ● 儀表板打開或沒有安全罩時不準作業。 	Chinese 警告
<ul style="list-style-type: none"> ● 얼굴로부터 용접가스를 멀리하십시오. ● 호흡지역으로부터 용접가스를 제거하기 위해 가스제거기나 통풍기를 사용하십시오. 	<ul style="list-style-type: none"> ● 보수전에 전원을 차단하십시오. 	<ul style="list-style-type: none"> ● 판넬이 열린 상태로 작동치 마십시오. 	Korean 위험
<ul style="list-style-type: none"> ● ابعد رأسك بعيداً عن الدخان. ● استعمل التهوية أو جهاز ضغط الدخان للخارج لكي تبعد الدخان عن المنطقة التي تتنفس فيها. 	<ul style="list-style-type: none"> ● أقطع التيار الكهربائي قبل القيام بأية صيانة. 	<ul style="list-style-type: none"> ● لا تشغيل هذا الجهاز اذا كانت الاغطية الحديدية الواقية ليست عليه. 	Arabic تحذير

LEIA E COMPREENDA AS INSTRUÇÕES DO FABRICANTE PARA ESTE EQUIPAMENTO E AS PARTES DE USO, E SIGA AS PRÁTICAS DE SEGURANÇA DO EMPREGADOR.

使う機械や溶材のメーカーの指示書をよく読み、まず理解して下さい。そして貴社の安全規定に従って下さい。

請詳細閱讀並理解製造廠提供的說明以及應該使用的銀焊材料，並請遵守貴方的有關勞動保護規定。

이 제품에 동봉된 작업지침서를 숙지하시고 귀사의 작업자 안전수칙을 준수하시기 바랍니다.

اقرأ بتمعن وافهم تعليمات المصنع المنتج لهذه المعدات والمواد قبل استعمالها واتبع تعليمات الوقاية لصاحب العمل.

CUSTOMER ASSISTANCE POLICY

The business of The Lincoln Electric Company is manufacturing and selling high quality welding equipment, consumables, and cutting equipment. Our challenge is to meet the needs of our customers and to exceed their expectations. On occasion, purchasers may ask Lincoln Electric for advice or information about their use of our products. We respond to our customers based on the best information in our possession at that time. Lincoln Electric is not in a position to warrant or guarantee such advice, and assumes no liability, with respect to such information or advice. We expressly disclaim any warranty of any kind, including any warranty of fitness for any customer's particular purpose, with respect to such information or advice. As a matter of practical consideration, we also cannot assume any responsibility for updating or correcting any such information or advice once it has been given, nor does the provision of information or advice create, expand or alter any warranty with respect to the sale of our products.

Lincoln Electric is a responsive manufacturer, but the selection and use of specific products sold by Lincoln Electric is solely within the control of, and remains the sole responsibility of the customer. Many variables beyond the control of Lincoln Electric affect the results obtained in applying these types of fabrication methods and service requirements.

Subject to Change – This information is accurate to the best of our knowledge at the time of printing. Please refer to www.lincolnelectric.com for any updated information.



THE LINCOLN ELECTRIC COMPANY

22801 St. Clair Avenue • Cleveland, OH • 44117-1199 • U.S.A.
Phone: +1.216.481.8100 • www.lincolnelectric.com