

# WELD-PAK 3200HD WIRING DIAGRAM M20801 REV: A

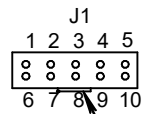

- Do not operate with covers removed.
- Disconnect input power by unplugging power cord before servicing.
- Do not touch electrically live parts
- Only qualified persons should install, use or service this machine.

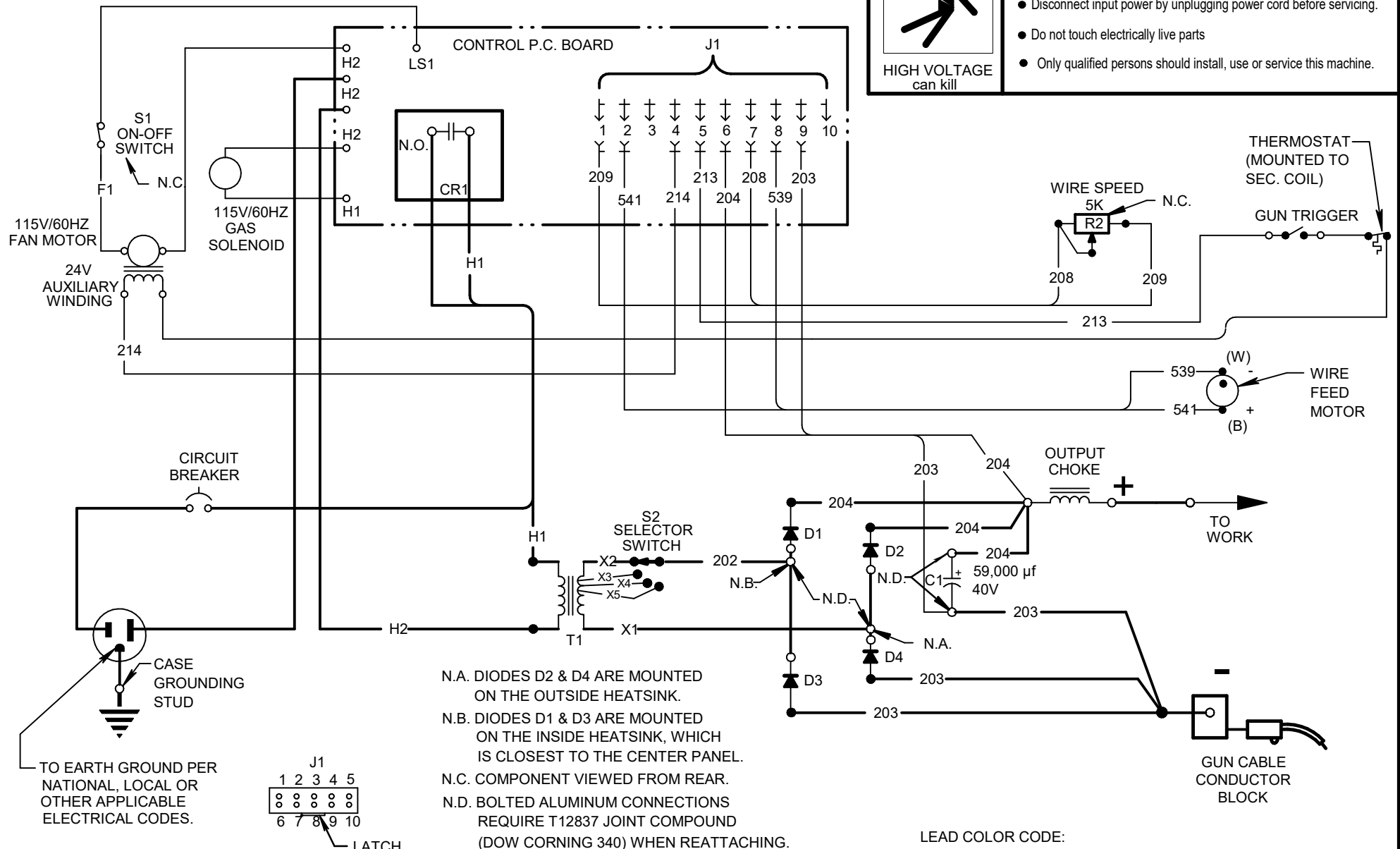

CAVITY NUMBERING SEQUENCE (COMPONENT SIDE OF BOARD)

- N.A. DIODES D2 & D4 ARE MOUNTED ON THE OUTSIDE HEATSINK.
- N.B. DIODES D1 & D3 ARE MOUNTED ON THE INSIDE HEATSINK, WHICH IS CLOSEST TO THE CENTER PANEL.
- N.C. COMPONENT VIEWED FROM REAR.
- N.D. BOLTED ALUMINUM CONNECTIONS REQUIRE T12837 JOINT COMPOUND (DOW CORNING 340) WHEN REATTACHING.

LEAD COLOR CODE:  
B-BLACK  
W-WHITE

