

POWER MIG 215 MACHINE SCHEMATIC L12308 REV: A

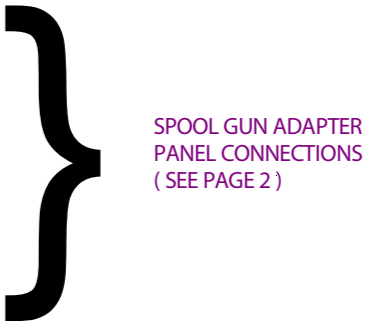

CAVITY NUMBERING SEQUENCE (COMPONENT SIDE OF P.C. BOARD)	LEAD COLOR CODE:	COMPONENT VALUE UNITS:
<p>(NON-LEAD SIDE OF CONNECTOR)</p> <p>J4 (TRIGGER, TACHOMETER, MOTOR SIDE)</p>	B-BLACK G-GREEN O-ORANGE R-RED U-BLUE W-WHITE Y-YELLOW	CAPACITOR: MFD/VOLTS RESISTOR: OHMS/WATTS CONNECTOR PIN NUMBERS: EX. 12 PIN CONNECTOR VIEW OF CONNECTOR ON PC BOARD
LABELS: COMMON FRAME GROUND EARTH GROUND		

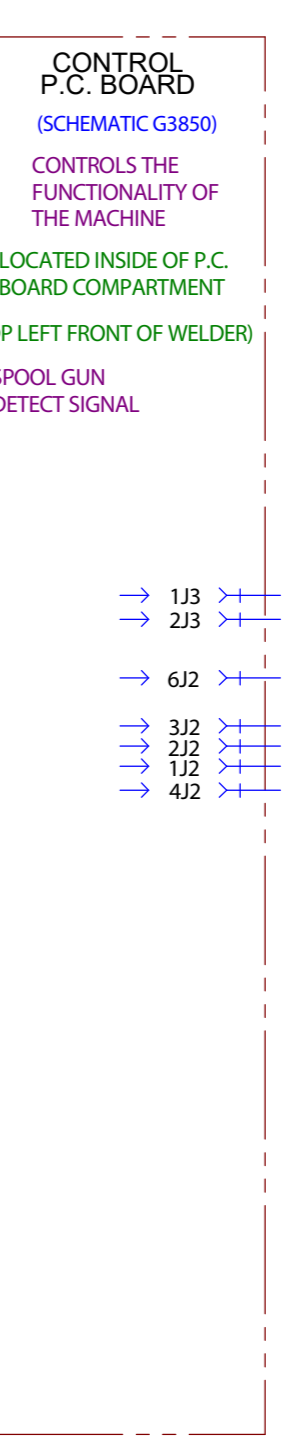
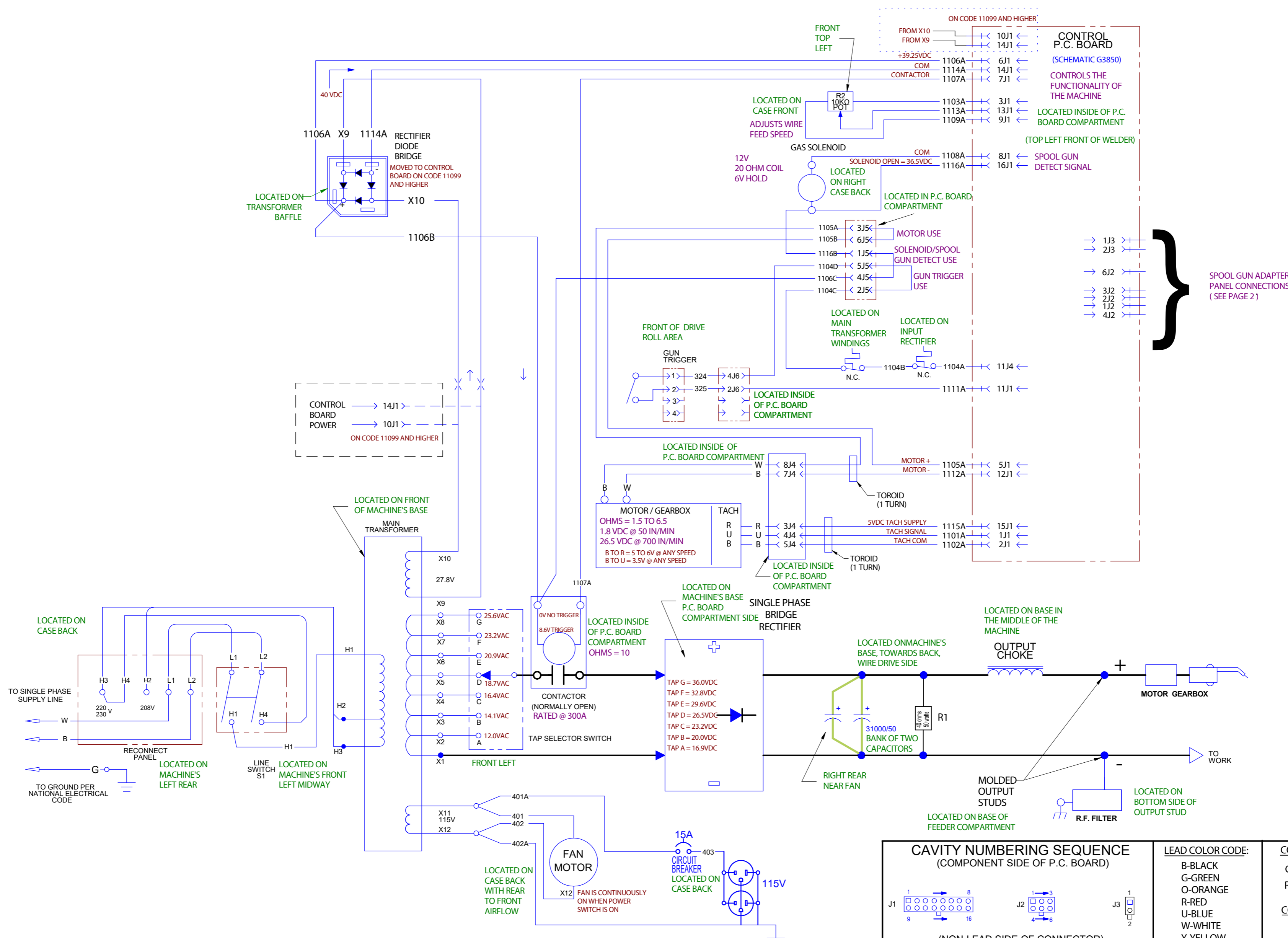
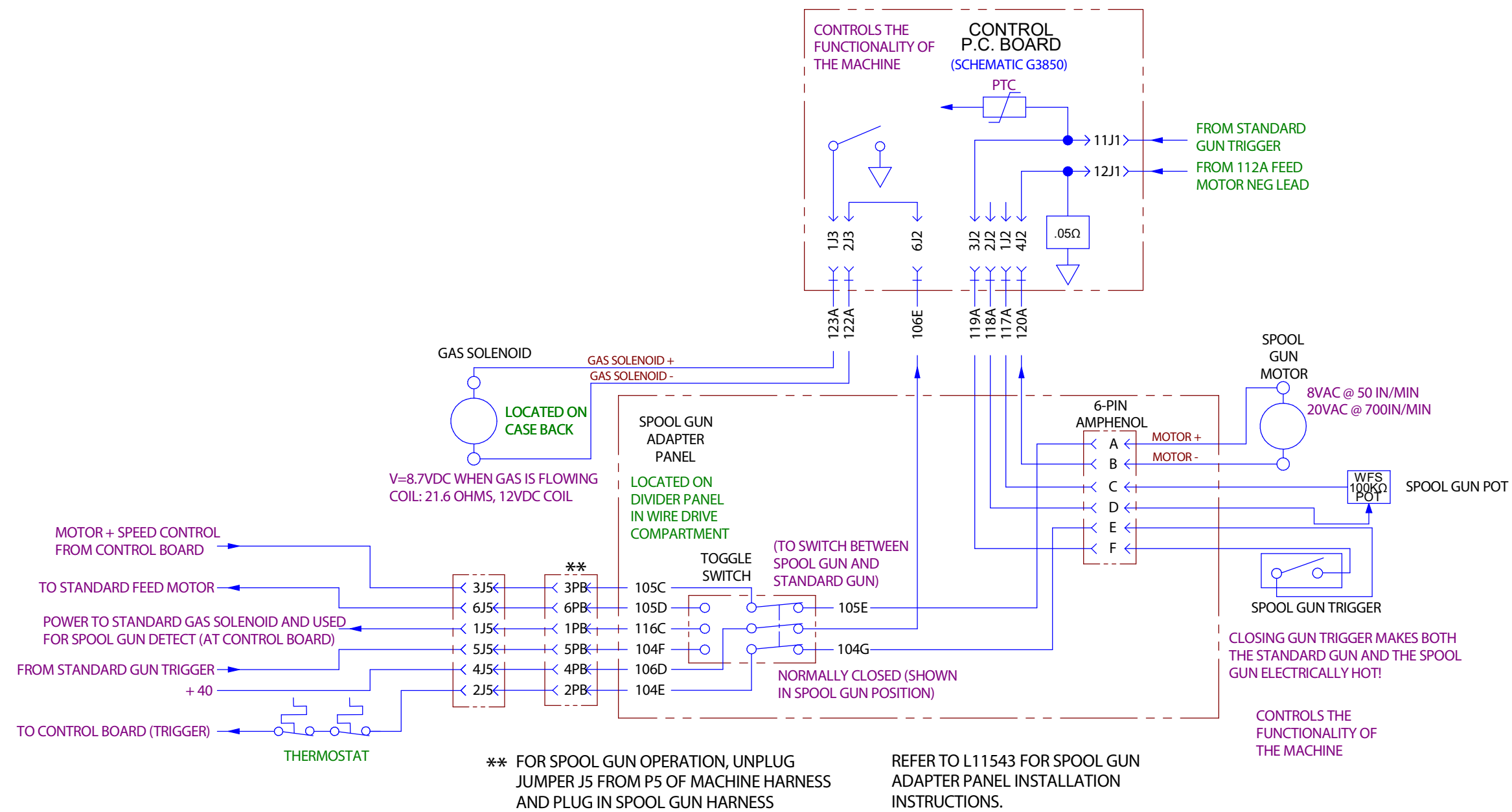

CAVITY NUMBERING SEQUENCE (COMPONENT SIDE OF P.C. BOARD)	LEAD COLOR CODE:	COMPONENT VALUE UNITS:
<p>(NON-LEAD SIDE OF CONNECTOR)</p>	<p>B-BLACK G-GREEN O-ORANGE R-RED U-BLUE W-WHITE Y-YELLOW</p> <p>LABELS: COMMON FRAME GROUND EARTH GROUND</p>	<p>CAPACITOR: MFD/VOLTS RESISTOR: OHMS/WATTS</p> <p>CONNECTOR PIN NUMBERS: EX. 12 PIN CONNECTOR</p> <p>VIEW OF CONNECTOR ON PC BOARD</p>