

REPLACEMENT PARTS LIST **117-086, 83095, 83096, P3095, 20676**  
 90A MIG WELDER  
 MODEL 83095 & 83096 (117-086)

# 117-086, 83095, 83096, P3095, 20676

Item	Lincoln Stock #	Customer #	Description
1	239-288-666	1752242	Ground Clamp
2	238-694-666	1752180	Ground Cable
3	248-376-666	800042676	Power Cord
4	312-499-666	2380083	Knob Wire Speed
5	<b>238-695-666</b>	<b>800042696</b>	<b>Mig Gun Assy</b>
6	246-501-666	2380064	Heat Switch
7	246-499-666	1752208	Power Switch
8	880-465-666	800042704	Circuit Board
9	880-463-888	800042679	Transformer
10	412-740-666	1752702	Handle Bracket
11	412-742-666	800042700	Handle Tube
12	246-500-666	1752217	Thermostat
13	880-464-666	800042695	Rectifier
14	411-088-016	800042698	Internal Panel
15	411-091-016	800042711	Rear Panel
16	411-092-016	800042713	Base
17	131-428-666	800042499	Spindle Kit
18	880-467-666	2380068	Wire Feed Unit

Item	Lincoln #	Stock	Customer #	Description
19	312-500-666		800042705	Knob Gas/No Gas
20	411-089-116		800042699	Front Panel - 83095, 83096

## Not Shown

21	411-093-026		800042715	Cover
22	411-090-026		800042703	Left Side Panel
23	412-741-666		2380098	Hinge
24	KP21T-50, KH725	43480, M15578, 334-203-000		Nozzle for Steel Welding
	KP21T-62	43300, 334-210-300		Nozzle for Aluminium Welding
	KP21-62-FAS	43290, KP1956-1, M15577, 334-211-300		Spot Welding Nozzle
	KP1939-1, KH726			Flux Core Nozzle
25	KP11-25, KH710	43090, M15522, 334-159-300, KP2039-1B1		Contact Tips .025"
	KP11-30, KH711	43100, M15523, 334-160-300, KP2039-2B1		Contact Tips .030"
26	KP2080-1			Steel Liner (replaces plastic)
27	334-579-666	800042737		Conductor Tube with Cover
	334-439-000			Gas Diffuser only
28	131-429-666	190000412		Handle Assy
29	252-071-666	2380132		Gas Valve
30	<b>059-245-666</b>			<b>Gas Hose</b>
31	<b>334-303-001</b>	<b>334-286-666</b>		<b>Gas Regulator</b>

10/22/2009

Model	Primary Input	Duty Cycle
117-086	120V, 15 amp plug	10% @ 80 amps

Agency	Rated Output	Voltage Settings	Welding Thickness
CSA	80 amps	4	26 ga.(GS) or 18 ga. (GL) to 3/16"

# 117-086, 83095, 83096, P3095, 20676

Input 120Vac

### Drive Motor DCv readings

	Max speed	Min speed
Min 1 -	17.8	7.1
Min 2 -	19.1	7.7
Max 1 -	20.1	9.9
Max 2 -	20.6	9.9

### DC Open Circuit Voltages

Trigger Pulled	Trigger not Pulled
Min1 - 18.7	26.1
Min2 - 20.7	28.8
Max1 - 23.3	32.3
Max2 - 26.3	36.3

### AC Transformer Voltages

Min1 -	21.9
Min2 -	24.1
Max1 -	27.0
Max2 -	30.4

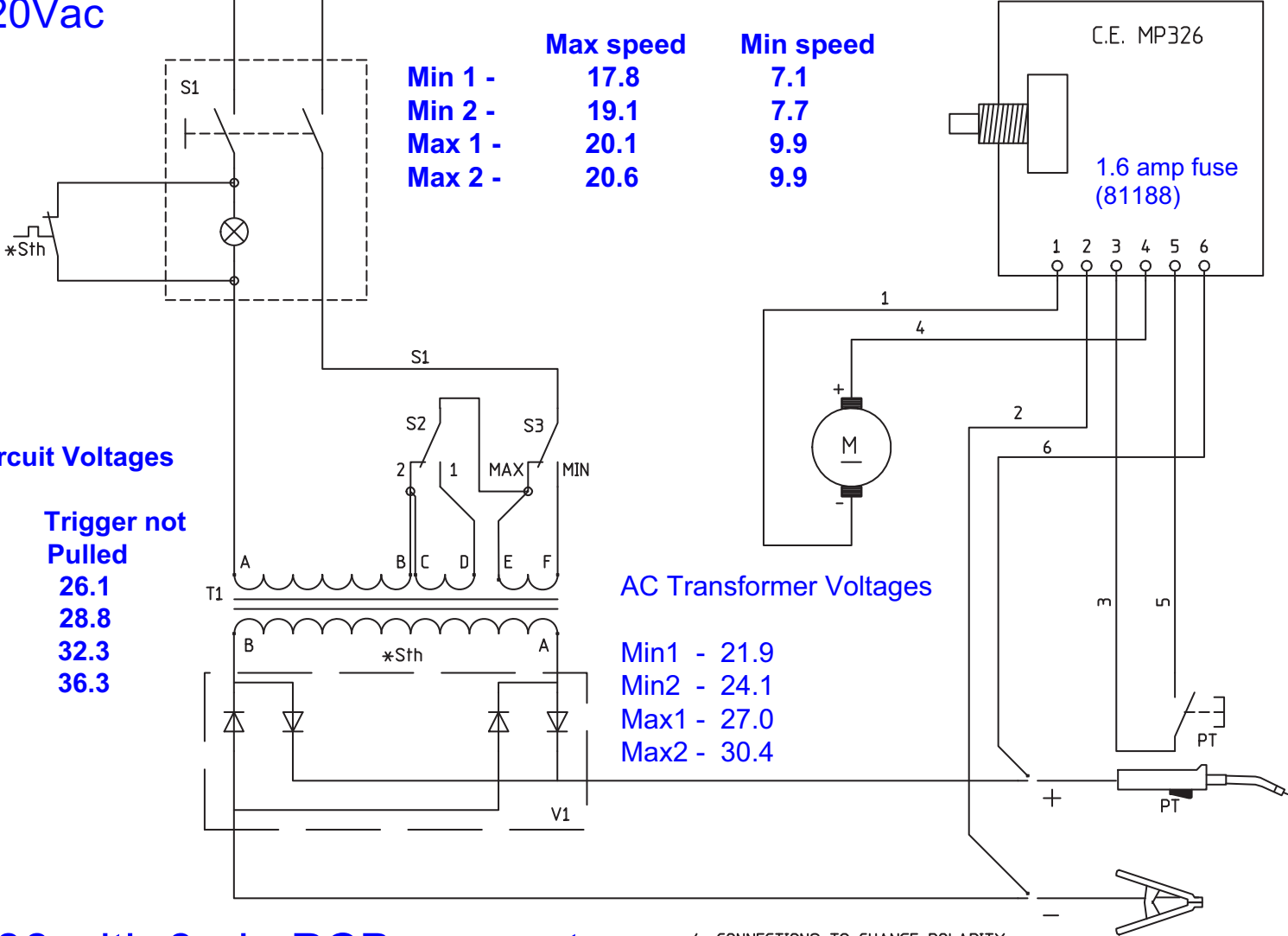

117-086 with 6-pin PCB connector

+/- CONNECTIONS TO CHANGE POLARITY

# 117-086, 83095, 83096, P3095, 20676

## 117-086 wiring with 4-pin PCB connector

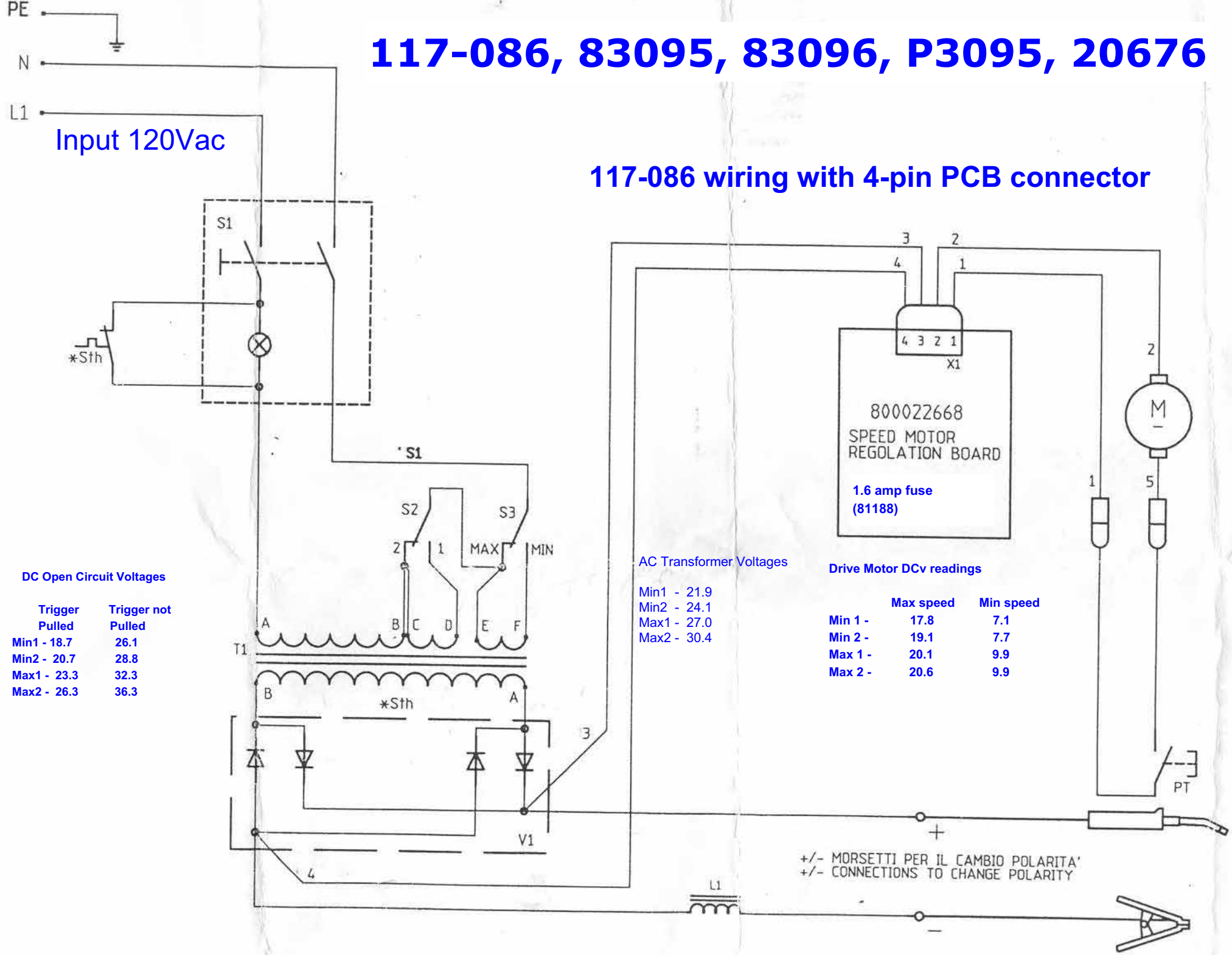

### DC Open Circuit Voltages

Trigger Pulled	Trigger not Pulled
Min1 - 18.7	26.1
Min2 - 20.7	28.8
Max1 - 23.3	32.3
Max2 - 26.3	36.3

### AC Transformer Voltages

- Min1 - 21.9
- Min2 - 24.1
- Max1 - 27.0
- Max2 - 30.4

### Drive Motor DCv readings

	Max speed	Min speed
Min 1 -	17.8	7.1
Min 2 -	19.1	7.7
Max 1 -	20.1	9.9
Max 2 -	20.6	9.9

+/- MORSETTI PER IL CAMBIO POLARITA'  
 +/- CONNECTIONS TO CHANGE POLARITY

117-086-000, 83095





117-086-000, 83095





117-086-000, 83095



117-086-000 Accy. kit



800042615