

SMALL WIRE FEEDER WELDERS MACHINE SCHEMATIC M24683 REV:A

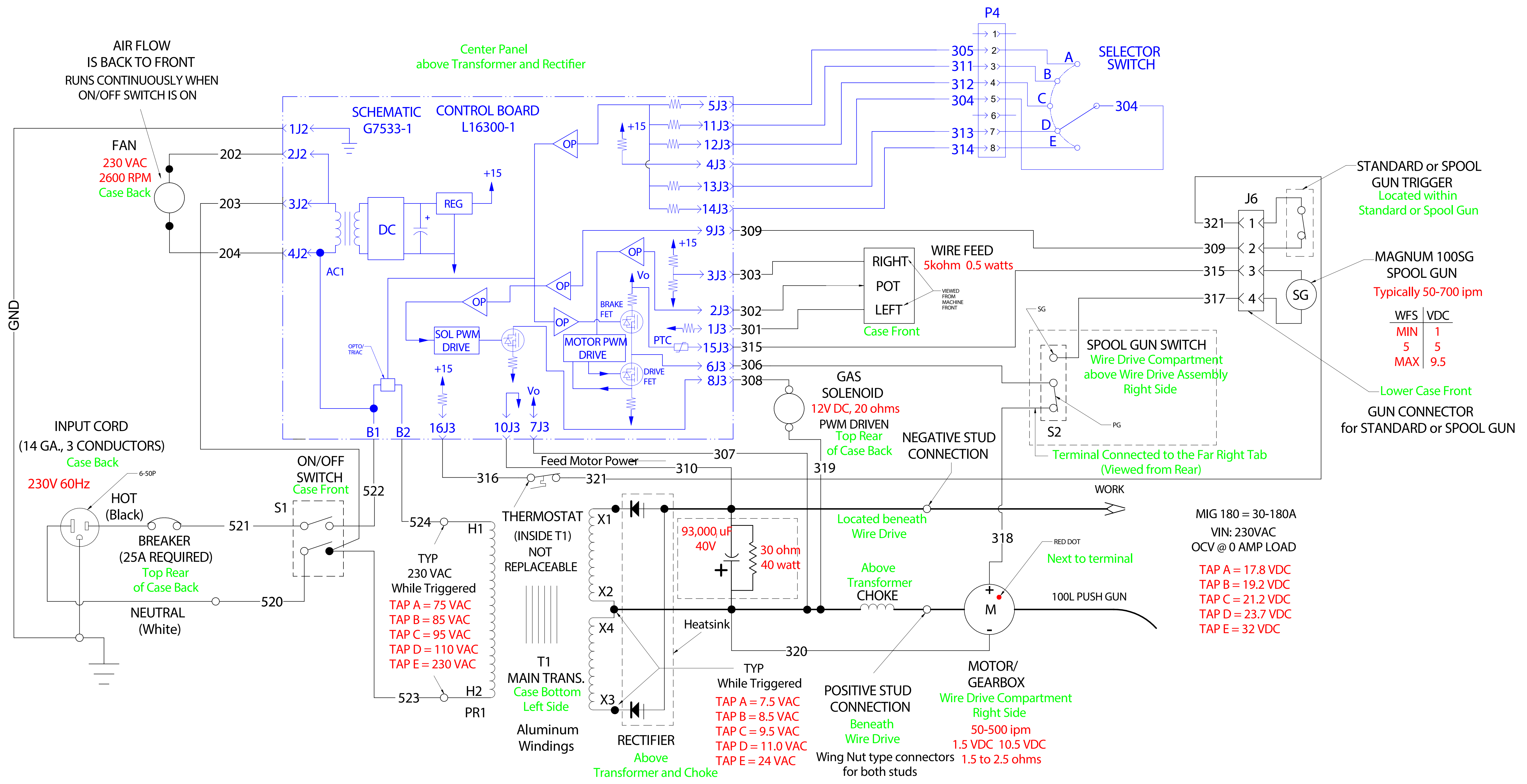

MIG 180 = 30-180A
 VIN: 230VAC
 OCV @ 0 AMP LOAD
 TAP A = 17.8 VDC
 TAP B = 19.2 VDC
 TAP C = 21.2 VDC
 TAP D = 23.7 VDC
 TAP E = 32 VDC

STANDARD or SPOOL GUN TRIGGER
 Located within Standard or Spool Gun

MAGNUM 100SG SPOOL GUN
 Typically 50-700 ipm

WFS	VDC
MIN	1
5	5
MAX	9.5

Lower Case Front GUN CONNECTOR for STANDARD or SPOOL GUN

LEAD COLOR CODE:	COMPONENT VALUE UNITS:
B-BLACK	CAPACITOR: MFD/VOLTS
G-GREEN	RESISTOR: OHMS/WATTS
O-ORANGE	
R-RED	
U-BLUE	
W-WHITE	
Y-YELLOW	
LABELS:	CONNECTOR PIN NUMBERS:
↕ COMMON	EX: 12 PIN CONNECTOR
⏏ FRAME GROUND	1 2 → 6
⏏ EARTH GROUND	7 → 12
	LATCH
	VIEW OF CONNECTOR ON PC BOARD