



NOTE: This manual will cover most of the troubleshooting and repair procedures for the code numbers listed. Some variances may exist when troubleshooting/repairing later code numbers.

MULTI-SOURCE™

For use with machines having Code Numbers:

10668

SERVICE MANUAL

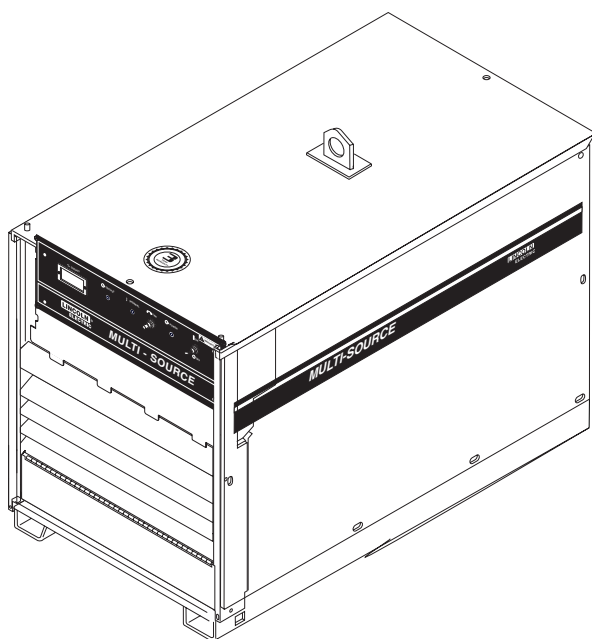

⚠ WARNING

⚠ CALIFORNIA PROPOSITION 65 WARNINGS ⚠

Diesel engine exhaust and some of its constituents are known to the State of California to cause cancer, birth defects, and other reproductive harm.

The Above For Diesel Engines

The engine exhaust from this product contains chemicals known to the State of California to cause cancer, birth defects, or other reproductive harm.

The Above For Gasoline Engines

ARC WELDING CAN BE HAZARDOUS. PROTECT YOURSELF AND OTHERS FROM POSSIBLE SERIOUS INJURY OR DEATH. KEEP CHILDREN AWAY. PACEMAKER WEARERS SHOULD CONSULT WITH THEIR DOCTOR BEFORE OPERATING.

Read and understand the following safety highlights. For additional safety information, it is strongly recommended that you purchase a copy of "Safety in Welding & Cutting - ANSI Standard Z49.1" from the American Welding Society, P.O. Box 351040, Miami, Florida 33135 or CSA Standard W117.2-1974. A Free copy of "Arc Welding Safety" booklet E205 is available from the Lincoln Electric Company, 22801 St. Clair Avenue, Cleveland, Ohio 44117-1199.

BE SURE THAT ALL INSTALLATION, OPERATION, MAINTENANCE AND REPAIR PROCEDURES ARE PERFORMED ONLY BY QUALIFIED INDIVIDUALS.



FOR ENGINE powered equipment.

1.a. Turn the engine off before troubleshooting and maintenance work unless the maintenance work requires it to be running.



1.b. Operate engines in open, well-ventilated areas or vent the engine exhaust fumes outdoors.



1.c. Do not add the fuel near an open flame welding arc or when the engine is running. Stop the engine and allow it to cool before refueling to prevent spilled fuel from vaporizing on contact with hot engine parts and igniting. Do not spill fuel when filling tank. If fuel is spilled, wipe it up and do not start engine until fumes have been eliminated.

1.d. Keep all equipment safety guards, covers and devices in position and in good repair. Keep hands, hair, clothing and tools away from V-belts, gears, fans and all other moving parts when starting, operating or repairing equipment.

1.e. In some cases it may be necessary to remove safety guards to perform required maintenance. Remove guards only when necessary and replace them when the maintenance requiring their removal is complete. Always use the greatest care when working near moving parts.



1.f. Do not put your hands near the engine fan. Do not attempt to override the governor or idler by pushing on the throttle control rods while the engine is running.

1.g. To prevent accidentally starting gasoline engines while turning the engine or welding generator during maintenance work, disconnect the spark plug wires, distributor cap or magneto wire as appropriate.



1.h. To avoid scalding, do not remove the radiator pressure cap when the engine is hot.



ELECTRIC AND MAGNETIC FIELDS may be dangerous

2.a. Electric current flowing through any conductor causes localized Electric and Magnetic Fields (EMF). Welding current creates EMF fields around welding cables and welding machines

2.b. EMF fields may interfere with some pacemakers, and welders having a pacemaker should consult their physician before welding.

2.c. Exposure to EMF fields in welding may have other health effects which are now not known.

2.d. All welders should use the following procedures in order to minimize exposure to EMF fields from the welding circuit:

2.d.1. Route the electrode and work cables together - Secure them with tape when possible.

2.d.2. Never coil the electrode lead around your body.

2.d.3. Do not place your body between the electrode and work cables. If the electrode cable is on your right side, the work cable should also be on your right side.

2.d.4. Connect the work cable to the workpiece as close as possible to the area being welded.

2.d.5. Do not work next to welding power source.

Mar '95



ELECTRIC SHOCK can kill.

3.a. The electrode and work (or ground) circuits are electrically “hot” when the welder is on. Do not touch these “hot” parts with your bare skin or wet clothing. Wear dry, hole-free gloves to insulate hands.

3.b. Insulate yourself from work and ground using dry insulation. Make certain the insulation is large enough to cover your full area of physical contact with work and ground.

In addition to the normal safety precautions, if welding must be performed under electrically hazardous conditions (in damp locations or while wearing wet clothing; on metal structures such as floors, gratings or scaffolds; when in cramped positions such as sitting, kneeling or lying, if there is a high risk of unavoidable or accidental contact with the workpiece or ground) use the following equipment:

- Semiautomatic DC Constant Voltage (Wire) Welder.
- DC Manual (Stick) Welder.
- AC Welder with Reduced Voltage Control.

3.c. In semiautomatic or automatic wire welding, the electrode, electrode reel, welding head, nozzle or semiautomatic welding gun are also electrically “hot”.

3.d. Always be sure the work cable makes a good electrical connection with the metal being welded. The connection should be as close as possible to the area being welded.

3.e. Ground the work or metal to be welded to a good electrical (earth) ground.

3.f. Maintain the electrode holder, work clamp, welding cable and welding machine in good, safe operating condition. Replace damaged insulation.

3.g. Never dip the electrode in water for cooling.

3.h. Never simultaneously touch electrically “hot” parts of electrode holders connected to two welders because voltage between the two can be the total of the open circuit voltage of both welders.

3.i. When working above floor level, use a safety belt to protect yourself from a fall should you get a shock.

3.j. Also see Items 6.c. and 8.



ARC RAYS can burn.

4.a. Use a shield with the proper filter and cover plates to protect your eyes from sparks and the rays of the arc when welding or observing open arc welding. Headshield and filter lens should conform to ANSI Z87.1 standards.

4.b. Use suitable clothing made from durable flame-resistant material to protect your skin and that of your helpers from the arc rays.

4.c. Protect other nearby personnel with suitable, non-flammable screening and/or warn them not to watch the arc nor expose themselves to the arc rays or to hot spatter or metal.



FUMES AND GASES can be dangerous.

5.a. Welding may produce fumes and gases hazardous to health. Avoid breathing these fumes and gases. When welding, keep your head out of the fume. Use enough ventilation and/or exhaust at the arc to keep fumes and gases away from the breathing zone. **When welding with electrodes which require special ventilation such as stainless or hard facing (see instructions on container or MSDS) or on lead or cadmium plated steel and other metals or coatings which produce highly toxic fumes, keep exposure as low as possible and below Threshold Limit Values (TLV) using local exhaust or mechanical ventilation. In confined spaces or in some circumstances, outdoors, a respirator may be required. Additional precautions are also required when welding on galvanized steel.**

5.b. Do not weld in locations near chlorinated hydrocarbon vapors coming from degreasing, cleaning or spraying operations. The heat and rays of the arc can react with solvent vapors to form phosgene, a highly toxic gas, and other irritating products.

5.c. Shielding gases used for arc welding can displace air and cause injury or death. Always use enough ventilation, especially in confined areas, to insure breathing air is safe.

5.d. Read and understand the manufacturer’s instructions for this equipment and the consumables to be used, including the material safety data sheet (MSDS) and follow your employer’s safety practices. MSDS forms are available from your welding distributor or from the manufacturer.

5.e. Also see item 1.b.

Mar '95

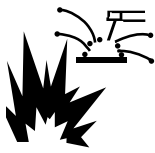

WELDING SPARKS can cause fire or explosion.

- 6.a. Remove fire hazards from the welding area. If this is not possible, cover them to prevent the welding sparks from starting a fire. Remember that welding sparks and hot materials from welding can easily go through small cracks and openings to adjacent areas. Avoid welding near hydraulic lines. Have a fire extinguisher readily available.
- 6.b. Where compressed gases are to be used at the job site, special precautions should be used to prevent hazardous situations. Refer to "Safety in Welding and Cutting" (ANSI Standard Z49.1) and the operating information for the equipment being used.
- 6.c. When not welding, make certain no part of the electrode circuit is touching the work or ground. Accidental contact can cause overheating and create a fire hazard.
- 6.d. Do not heat, cut or weld tanks, drums or containers until the proper steps have been taken to insure that such procedures will not cause flammable or toxic vapors from substances inside. They can cause an explosion even though they have been "cleaned". For information, purchase "Recommended Safe Practices for the Preparation for Welding and Cutting of Containers and Piping That Have Held Hazardous Substances", AWS F4.1 from the American Welding Society (see address above).
- 6.e. Vent hollow castings or containers before heating, cutting or welding. They may explode.
- 6.f. Sparks and spatter are thrown from the welding arc. Wear oil free protective garments such as leather gloves, heavy shirt, cuffless trousers, high shoes and a cap over your hair. Wear ear plugs when welding out of position or in confined places. Always wear safety glasses with side shields when in a welding area.
- 6.g. Connect the work cable to the work as close to the welding area as practical. Work cables connected to the building framework or other locations away from the welding area increase the possibility of the welding current passing through lifting chains, crane cables or other alternate circuits. This can create fire hazards or overheat lifting chains or cables until they fail.
- 6.h. Also see item 1.c.



CYLINDER may explode if damaged.

- 7.a. Use only compressed gas cylinders containing the correct shielding gas for the process used and properly operating regulators designed for the gas and pressure used. All hoses, fittings, etc. should be suitable for the application and maintained in good condition.
- 7.b. Always keep cylinders in an upright position securely chained to an undercarriage or fixed support.
- 7.c. Cylinders should be located:
 - Away from areas where they may be struck or subjected to physical damage.
 - A safe distance from arc welding or cutting operations and any other source of heat, sparks, or flame.
- 7.d. Never allow the electrode, electrode holder or any other electrically "hot" parts to touch a cylinder.
- 7.e. Keep your head and face away from the cylinder valve outlet when opening the cylinder valve.
- 7.f. Valve protection caps should always be in place and hand tight except when the cylinder is in use or connected for use.
- 7.g. Read and follow the instructions on compressed gas cylinders, associated equipment, and CGA publication P-1, "Precautions for Safe Handling of Compressed Gases in Cylinders," available from the Compressed Gas Association 1235 Jefferson Davis Highway, Arlington, VA 22202.



FOR ELECTRICALLY powered equipment.

- 8.a. Turn off input power using the disconnect switch at the fuse box before working on the equipment.
- 8.b. Install equipment in accordance with the U.S. National Electrical Code, all local codes and the manufacturer's recommendations.
- 8.c. Ground the equipment in accordance with the U.S. National Electrical Code and the manufacturer's recommendations.

Mar '95

PRÉCAUTIONS DE SÛRETÉ

Pour votre propre protection lire et observer toutes les instructions et les précautions de sûreté spécifiques qui paraissent dans ce manuel aussi bien que les précautions de sûreté générales suivantes:

Sûreté Pour Soudage A L'Arc

1. Protégez-vous contre la secousse électrique:
 - a. Les circuits à l'électrode et à la pièce sont sous tension quand la machine à souder est en marche. Eviter toujours tout contact entre les parties sous tension et la peau nue ou les vêtements mouillés. Porter des gants secs et sans trous pour isoler les mains.
 - b. Faire très attention de bien s'isoler de la masse quand on soude dans des endroits humides, ou sur un plancher métallique ou des grilles métalliques, principalement dans les positions assis ou couché pour lesquelles une grande partie du corps peut être en contact avec la masse.
 - c. Maintenir le porte-électrode, la pince de masse, le câble de soudage et la machine à souder en bon et sûr état de fonctionnement.
 - d. Ne jamais plonger le porte-électrode dans l'eau pour le refroidir.
 - e. Ne jamais toucher simultanément les parties sous tension des porte-électrodes connectés à deux machines à souder parce que la tension entre les deux pinces peut être le total de la tension à vide des deux machines.
 - f. Si on utilise la machine à souder comme une source de courant pour soudage semi-automatique, ces précautions pour le porte-électrode s'appliquent aussi au pistolet de soudage.
2. Dans le cas de travail au dessus du niveau du sol, se protéger contre les chutes dans le cas où on recoit un choc. Ne jamais enrouler le câble-électrode autour de n'importe quelle partie du corps.
3. Un coup d'arc peut être plus sévère qu'un coup de soliel, donc:
 - a. Utiliser un bon masque avec un verre filtrant approprié ainsi qu'un verre blanc afin de se protéger les yeux du rayonnement de l'arc et des projections quand on soude ou quand on regarde l'arc.
 - b. Porter des vêtements convenables afin de protéger la peau de soudeur et des aides contre le rayonnement de l'arc.
 - c. Protéger l'autre personnel travaillant à proximité au soudage à l'aide d'écrans appropriés et non-inflammables.
4. Des gouttes de laitier en fusion sont émises de l'arc de soudage. Se protéger avec des vêtements de protection libres de l'huile, tels que les gants en cuir, chemise épaisse, pantalons sans revers, et chaussures montantes.
5. Toujours porter des lunettes de sécurité dans la zone de soudage. Utiliser des lunettes avec écrans latéraux dans les

zones où l'on pique le laitier.

6. Eloigner les matériaux inflammables ou les recouvrir afin de prévenir tout risque d'incendie dû aux étincelles.
7. Quand on ne soude pas, poser la pince à une endroit isolé de la masse. Un court-circuit accidentel peut provoquer un échauffement et un risque d'incendie.
8. S'assurer que la masse est connectée le plus près possible de la zone de travail qu'il est pratique de le faire. Si on place la masse sur la charpente de la construction ou d'autres endroits éloignés de la zone de travail, on augmente le risque de voir passer le courant de soudage par les chaînes de levage, câbles de grue, ou autres circuits. Cela peut provoquer des risques d'incendie ou d'échauffement des chaînes et des câbles jusqu'à ce qu'ils se rompent.
9. Assurer une ventilation suffisante dans la zone de soudage. Ceci est particulièrement important pour le soudage de tôles galvanisées plombées, ou cadmiées ou tout autre métal qui produit des fumées toxiques.
10. Ne pas souder en présence de vapeurs de chlore provenant d'opérations de dégraissage, nettoyage ou pistologie. La chaleur ou les rayons de l'arc peuvent réagir avec les vapeurs du solvant pour produire du phosgène (gas fortement toxique) ou autres produits irritants.
11. Pour obtenir de plus amples renseignements sur la sûreté, voir le code "Code for safety in welding and cutting" CSA Standard W 117.2-1974.

PRÉCAUTIONS DE SÛRETÉ POUR LES MACHINES À SOUDER À TRANSFORMATEUR ET À REDRESSEUR

1. Relier à la terre le châssis du poste conformément au code de l'électricité et aux recommandations du fabricant. Le dispositif de montage ou la pièce à souder doit être branché à une bonne mise à la terre.
2. Autant que possible, l'installation et l'entretien du poste seront effectués par un électricien qualifié.
3. Avant de faire des travaux à l'intérieur de poste, la débrancher à l'interrupteur à la boîte de fusibles.
4. Garder tous les couvercles et dispositifs de sûreté à leur place.

Mar. '93

MASTER TABLE OF CONTENTS FOR ALL SECTIONS

	Page
Safety	i-iv
Installation	Section A
Operation	Section B
Accessories	Section C
Maintenance	Section D
Theory of Operation	Section E
Troubleshooting and Repair	Section F
Electrical Diagrams	Section G
Parts Manual	P-367 SERIES

TABLE OF CONTENTS - INSTALLATION SECTION -

Installation	Section A
Technical Specifications	A-2
Safety Precautions.....	A-3
Select Proper Location	A-3
Stacking.....	A-3
Tilting	A-3
Electrical Input Connections.....	A-3
Fuse and Wire Sizes	A-4
Input and Grounding Connections	A-4
Reconnect Procedure	A-4
Output Connections.....	A-5
Paralleling	A-5
Multi-Source Output Limitations.....	A-5
Distribution Box	A-5
“Pig Tail” Leads and Connections	A-5

Return to Master TOC

Return to Master TOC

Return to Master TOC

Return to Master TOC

INSTALLATION

TECHNICAL SPECIFICATIONS - Multi-Source K1752-1

INPUT - THREE PHASE ONLY

Standard Voltage/Frequency	Input Current at Rated Output 100% Duty Cycle
380/415/50	99A
400/60	98A
440/50	79A
460/60	83A
550/50	66A
575/60	69A

RATED OUTPUT

Duty Cycle 100% Duty Cycle @ 50°C (122°F)	60 Hz-40 kW	
	Amps 533	Volts at Rated Amperes 75
	50 Hz-36 kW	
	Amps 475	Volts at Rated Amperes 75.8

CURRENT RANGE

OCV

0-650 A	Maximum Open Circuit Voltage 80V
---------	-------------------------------------

RECOMMENDED INPUT WIRE AND FUSE SIZES

INPUT VOLTAGE	HERTZ	INPUT AMPERE RATING	TYPE 75°C COPPER WIRE IN CONDUIT AWG(IEC-MM ²) SIZES 50°C (122°F) Ambient	TYPE 90°C COPPER WIRE IN CONDUIT AWG(IEC-MM ²) SIZES 50°C (122°F) Ambient	TYPE 75°C COPPER WIRE IN CONDUIT AWG(IEC-MM ²) SIZES 40°C (104°F) Ambient	TYPE 90°C COPPER WIRE IN CONDUIT AWG(IEC-MM ²) SIZES 40°C (104°F) Ambient	TYPE 75°C GROUND WIRE IN CONDUIT AWG(IEC-MM ²) SIZES	FUSE (SUPER LAG) OR BREAKER SIZE (AMPS)
380-415	50	99	1/0 (70)	2 (35)	2 (35)	3 (35)	6 (16)	150 Amp
460	60	83	2 (35)	3 (35)	3 (35)	4 (25)	6 (16)	125 Amp
575	60	69	3 (35)	4 (25)	4 (25)	4 (25)	8 (10)	100 Amp

PHYSICAL DIMENSIONS

HEIGHT 30.8 in 781 mm	WIDTH 22.2in 565 mm	DEPTH 41 in 1040 mm	NET WEIGHT 992 lbs. 450.5 kg.
-----------------------------	---------------------------	---------------------------	-------------------------------------

TEMPERATURE RANGES

OPERATING TEMPERATURE RANGE -40 to +122°F -40 to +50°C	STORAGE TEMPERATURE RANGE -40 to +185°F -40 to +85°C
--	--

Return to Section TOC

Return to Master TOC

INSTALLATION

Read entire Installation Section before installing the MULTI-SOURCE.

SAFETY PRECAUTIONS

⚠ WARNING



ELECTRIC SHOCK can kill.

- Have an electrician install and service this equipment.
- Turn the input power off at the fuse box before working on equipment.
- Do not touch electrically hot parts.
- The Multi-Source power supply should not be used if the green Safe Output light is not lit. The machine is designed to open its input contactor if output voltage peaks exceed the limits set by certain approval agencies. If the Safe Output light is on, the output voltage is within its designed operating range.

SELECT PROPER LOCATION

Place the power supply where clean cooling air can freely circulate in through the front louvers and out through the rear louvers. Dirt, dust or any foreign material that can be drawn into the welder should be kept at a minimum. Failure to observe these precautions can result in excessive operating temperatures and nuisance shut-downs.

STACKING

⚠ WARNING



FALLING EQUIPMENT can cause injury.

- Two Multi-Source machines can be stacked.
- Lift only with equipment of adequate lifting capacity.
- Be sure machine is stable when lifting.
- Do not stack more than two high.
- Do not stack the Multi-Source on top of any other machine.

Two MULTI-SOURCE machines can be stacked.

Follow these guidelines when stacking:

1. Select a firm, level surface capable of supporting the total weight of up to two machines (1984 pounds/901 kilograms).
2. Set the bottom machine in place.
3. Stack the second machine on top of it by aligning

the two holes in the base rails on the second machine with the two pins on top at the front of the bottom machine.

Note: The machines must be stacked with the Case Front of each machine flush with each other. See Figure A.1. below.

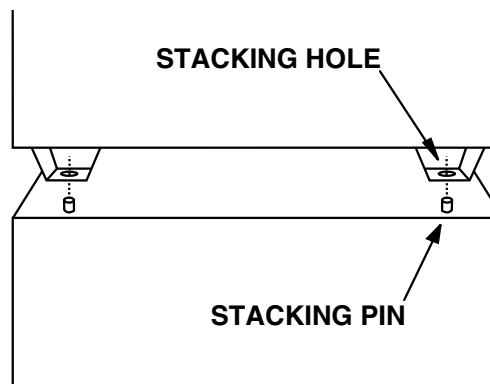

FIGURE A.1. - Stacking the MULTI-SOURCE

TILTING

The MULTI-SOURCE must be placed on a stable, level surface so it will not topple over.

ELECTRICAL INPUT CONNECTIONS

Before installing the machine, check that the input supply voltage, phase, and frequency are the same as the machine's voltage, phase, and frequency as specified on the machine's rating plate on the Case Front Assembly Control Panel. Connect input power supply by removing the rear access panel and connecting to the three line terminals on the input panel. See Figure A.2 for location of the machine's input cable entry opening and reconnect panel assembly for dual voltage machines.

Rear Panel

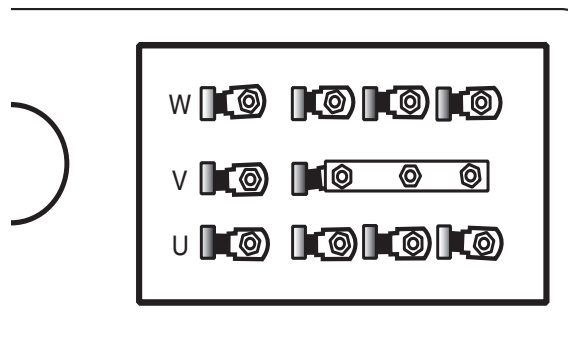

FIGURE A.2. - Input Power Supply Connection

INSTALLATION

FUSE AND WIRE SIZES

Protect the input circuit with the super lag fuses or delay type circuit breakers listed on the **Technical Specifications** page of this manual for the machine being used. They are also called inverse time or thermal/magnetic circuit breakers.

DO NOT use fuses or circuit breakers with a lower amp rating than recommended. This can result in nuisance tripping caused by inrush current even when machine is not being used for welding at high output currents. Use input and grounding wire sizes that meet local electrical codes, or see the **Technical Specifications** page in this manual.

INPUT AND GROUNDING CONNECTIONS

Note: A qualified electrician should connect the input power supply leads.

Input conductor is brought into the machine input box area through a hole in the rear panel sized to accommodate 2" (trade size) conduit and fittings. This is more than adequate for the largest conductors required.

Conductors must be lugged to attach to the three 3/8" studs on the input reconnect panel and the 5/16" ground stud marked with the symbol \oplus . The input voltage supplied determines the position required for the reconnect panel jumper. The three ranges on the standard machine are 380-415, 440-460 and 550-575. The machine is rated for 50 and 60 Hz operation. See the

Input Connection Diagram located on the inside of Case Back Input Access Door.

The conductor and fuse sizes in the **Technical Specification Section**, are per the National Electrical Code. The sizes are in American Wire Gauge (and the next largest standard metric size in mm²). National and local codes must be consulted before connecting a machine.

Protect the input circuit with the super lag fuses or delay type circuit breakers listed in the **Technical Specification Section**. (They are also called inverse time or thermal / magnetic circuit breakers.)

RECONNECT PROCEDURE

Multiple voltage machines are shipped connected to the highest input voltage listed on the machine's rating plate. Before installing the machine, check that the Reconnect Panel in the Input Box Assembly is connected for the proper voltage.

⚠ CAUTION

Failure to follow these instructions can cause immediate failure of components within the machine.

To reconnect a multiple voltage machine to a different voltage, remove input power and follow the input Connection Diagram located on the inside of the Case Back Input Access Door. This connection diagram is shown below.

FIGURE A.3. - Input Connection Diagram

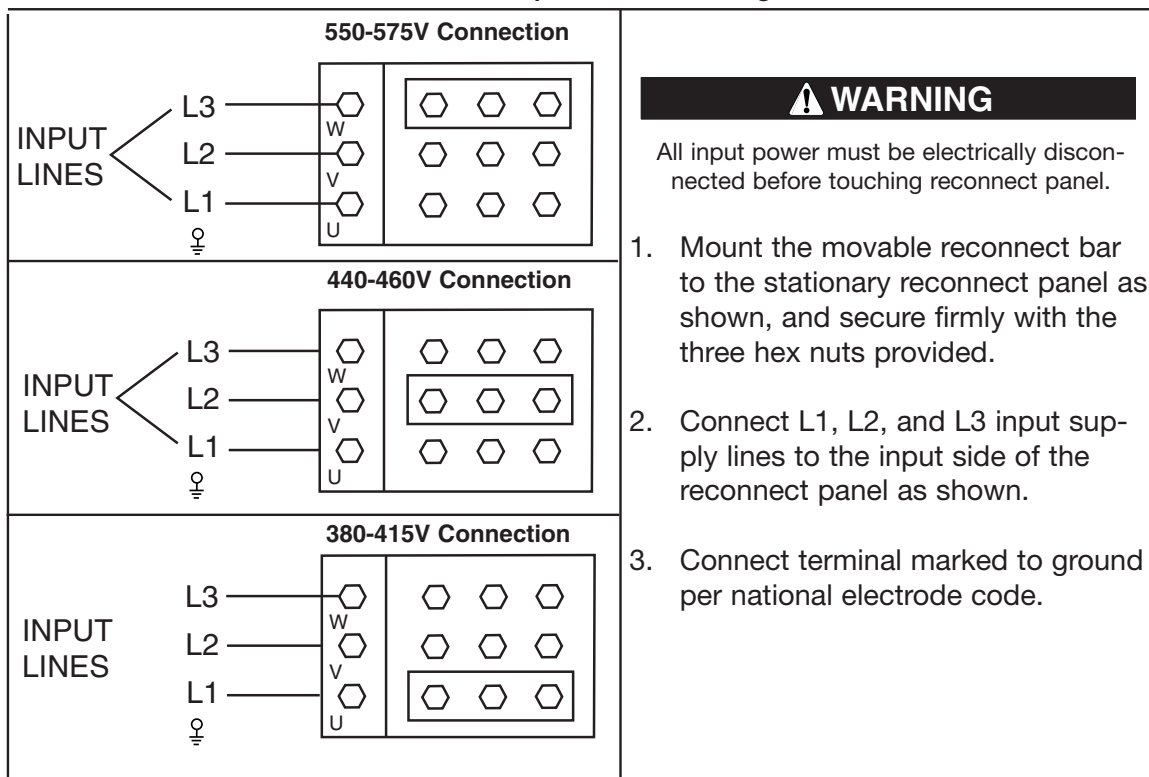

Return to Section TOC | Return to Master TOC

INSTALLATION

OUTPUT CONNECTIONS

The Multi-Source has two parallel connected output studs for positive and negative connections. Each one is rated to carry the full output current. For its maximum rated current at 100% duty cycle a minimum size of 4/0 AWG welding cable is recommended.

Connection of Electrode and Work Leads to Output terminals.

1. Set the POWER ON/OFF Toggle Switch to OFF.
2. Raise the hinged cover protecting the output terminals.
3. Insert the electrode lead up through the elliptical hole in the machine base below the positive output terminal. Pull through enough cable to reach the output terminal.
4. Connect electrode lead to the terminal .
5. Tighten the output terminal nut with a wrench.
6. Connect the work lead to the negative output terminal following steps 3-5.
7. Lower the cover to protect the output terminals.

FIGURE A.4. - Output Terminal Connections

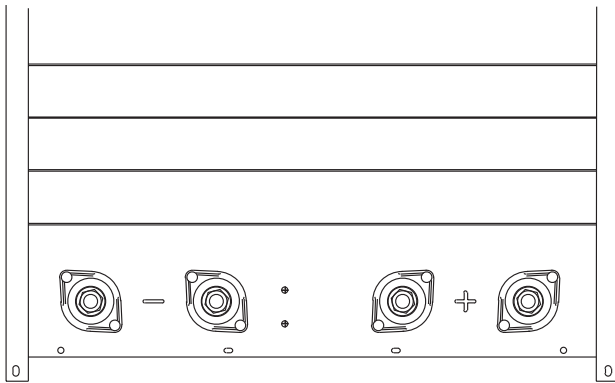

PARALLELING

Machines may be paralleled for increased output. The S20428 paralleling kit permits paralleling of two MULTI-SOURCE power supplies for supplying currents of up to 1000 amps, 100% duty cycle.

MULTI-SOURCE OUTPUT LIMITATIONS

The number of Multi-Weld Converters that may be connected to a single Multi-Source Power Source is determined by the following formula:

$$\text{Power Source (Volts x Amps) capacity} > 1.1 \times \text{Sum of Converters' (Volts x Amps) arcs}$$

The number of Multi-Weld 350s, the procedures used and the combined duty cycle of the arcs are only limited by the 40,000 (36,000 watts on 50Hz) watt rating of the Multi-Source supply. The machine is IP-23S rated and is designed for outdoor applications.

DISTRIBUTION BOX

The Multi-Weld Distribution Box (K1736-1) is available for interconnection of the Multi-System using the same "pig-tail" connection method provided with the Multi-Weld 350 converter. Six cable strain-relief ports are provided for connection of up to (12) cables for distribution or "daisy-chain" inter-connection to other boxes. Four "pig-tail" leads (see below) are included with the Box.

"PIG TAIL" LEADS AND CONNECTIONS

Accessory "pig tail" leads and Twist-Mate connectors are available from Lincoln for extra connections to the Multi-Weld 350 or the Distribution Box:

Order No.	Description:
CL012705	22in. (56cm) long 2/0 (70mm ²) cable with 0.5in. (13mm) hole lug and cut-off ends.
K852-70	Twist-Mate male insulated plug for 1/0-2/0 (50-70mm ²) cable
K852-95	Twist-Mate male insulated plug for 2/0-3/0 (70-95mm ²) cable.
K1759-70	Twist-Mate female insulated receptacle for 1/0-2/0 (50-70mm ²) cable.
K1759-95	Twist-Mate female insulated receptacle for 2/0-3/0 (70-95mm ²) cable

Return to Section TOC
Return to Master TOC

Return to Section TOC
Return to Master TOC

Return to Section TOC
Return to Master TOC

Return to Section TOC
Return to Master TOC

TABLE OF CONTENTS - OPERATION SECTION -

Operation	Section B
Safety Instructions	B-2
General Description	B-3
Recommended Equipment/Processes	B-3
Design Features and Advantages.....	B-3
Recommended Equipment/Connections	B-4
Controls and Settings	B-4

Return to Master TOC

Return to Master TOC

Return to Master TOC

Return to Master TOC

OPERATION

Read and understand this entire section before operating your machine.

SAFETY INSTRUCTIONS

WARNING



ELECTRIC SHOCK can kill.

- Do not touch electrically live parts or electrode with skin or wet clothing.
- Insulate yourself from work and ground.
- Always wear dry insulating gloves.



FUMES AND GASES can be dangerous.

- Keep your head out of fumes.
- Use ventilation or exhaust to remove fumes from breathing zone.



WELDING SPARKS can cause fire or explosion.

- Keep flammable material away.
- Do not weld on closed containers.



ARC RAYS can burn eyes and skin.

- Wear eye, ear and body protection.

Only qualified personnel should operate this equipment. See additional warning information at the front of this operators manual.

GENERAL DESCRIPTION

The Multi-Source is designed to supply power to the Multi-Weld welders. It has a wide range three phase AC input and can be operated on 50 or 60 Hz. The Multi-Source output peak voltage regulates against wide changes in output loading and input line voltage variations to supply a consistently stable voltage high enough to allow the Multi-Welds to provide good manual electrode capability.

Primary input voltage taps are selected by a single movable link on the reconnect panel. Main transformer auxiliary windings power the firing circuit and fan motor. The control auxiliary transformer has a single, wide range primary and is not reconnectable.

The Fan As Needed feature is activated by an output current of 20 amps DC or a thermostat on the main transformer iron.

An independent safety circuit on the Control board monitors the voltage peaks and opens the input contactor if the limit is exceeded. The green Safe Output light indicates when the machine output voltage is within the safe operating range.

Other indicator lights include the amber Thermal light that signals when the long term output current limit has been exceeded. This limit is determined by a thermostat sensing the temperature of the negative output lead from the secondary coils. The white Power light indicates when the Control board is energized. The three lights are high intensity LEDs for improved visibility in daylight.

The Output Power display uses high intensity LEDs to indicate the percentage of full rated output the machine is supplying.

Two additional thermostats protect the machine in the case of fan failure or blocked air flow. The SCR heat sink thermostat responds first to loss of air flow at normal output loads. This thermostat will disable the machine output. The transformer iron rear thermostat senses that the lamination (and thus the coil insulation) is over heating (which can happen even if the output is disabled). This thermostat will interrupt power to the Control board causing the input contactor to open until the iron cools.

The only user controls are an on-off toggle Power switch that energizes the machine and a 10 A circuit breaker protecting the fan auxiliary against short circuits.

RECOMMENDED EQUIPMENT/PROCESSES

The only recommended use for the Multi-Source is to power the Multi-Weld welders. It is conceivable that the machine could be used as a constant voltage DC power supply up to its rating of 40,000 watts (36,000 watts on 50Hz) output. Its output is stable with a wide range of inductive, resistive and capacitive loads but each application would have to be tested. The output is peak voltage regulated and at light resistive loads (maximum ripple) the average voltage deviates from peak voltage the most.

The Multi-Weld 350 K1752-1 is the recommended means by which to control the Multi-Source power supply. Connections between Multi-Source and Multi-Weld may be easily made using Twist-Mate male and female connectors and the K1736-1 distribution box. The Multi-Weld 350 has multi-process capability and may be used with manual and semi-automatic processes. When a wire feeder is required, an LN-25 (K449) is recommended. The Multi-Source 40kW (36kW on 50Hz) 80VDC buss power source (K1752-1) is recommended for use in the Multi-Weld system.

DESIGN FEATURES AND ADVANTAGES

- 80 volt peak OCV.
- 40,000 watts of output (36,000 watts on 50Hz) at 100% Duty Cycle.
- 75 volts at 533 amps (75.8 volts at 475 amps on 50 Hz) over 900 amps for 5 seconds without harming the machine.
- The machine has copper windings and a varnish dipped transformer for added environmental protection.
- Sealed external controls.
- Voltage ratings have been upgraded and used with higher voltage MOVs.
- Input lines are protected by the most rugged surge protection we've ever used.
- Indicator lights and digital display are extra bright to enhance visibility outdoors.
- HP_Cooling fan can operate on a wider range of voltage.

OPERATION

RECOMMENDED EQUIPMENT/CONNECTIONS

The Multi-weld 350 (K1735-1) is the recommended means by which to control the MULTI-SOURCE power supply. Connections between the MULTI-SOURCE and the Multi-weld may be easily made using Twist-Mate male and female connectors and the K1736-1 Distribution box.

For 1/0 Cable	Twist-Mate Male Connector	K852-70
	Twist-Mate Female Connector	K1759-70
For 3/0 Cable	Twist-Mate Male Connector	K852-90
	Twist-Mate Female Connector	K1759-90

The Multi-weld 350 has multi-process capability and may be used in manual and semi-automatic processes. When a wire feeder is required an LN-25 (K449) is recommended. The number of Multi-Weld 350s, the procedures used and the combined duty cycle of the arcs are only limited by the 40,000 watt (36,000 watts on 50 Hz) rating of the Multi-Source supply. The machine is IP-23S rated and is designed for outdoor applications.

CONTROLS AND SETTINGS

All operator controls and adjustments are located on the Case Front Assembly of the MULTI-SOURCE. See Figure B.1. below for the location of each control.

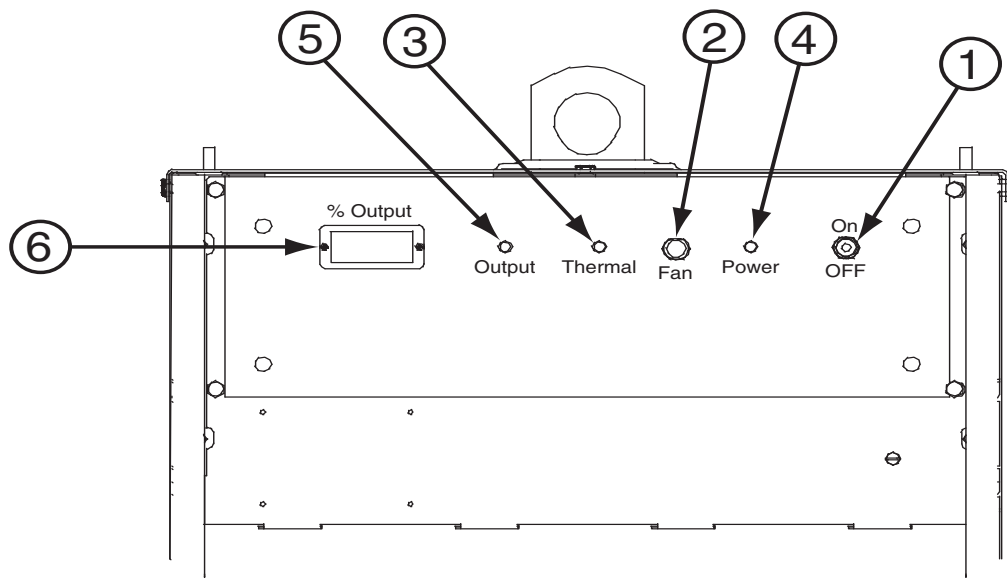

FIGURE B.1. - CONTROL PANEL

- 1. ON/OFF TOGGLE SWITCH:** This toggle switch turns the machine ON or OFF.
- 2. CIRCUIT BREAKER:** This 10 amp breaker protects the 120 VAC fan circuit.
- 3. AMBER LED:** This LED indicates that the temperature of the machine is too high.
- 4. WHITE LED:** This LED indicates that the control board is energized.
- 5. GREEN LED:** This LED indicates that the machines output voltage is within the safe operating range.
- 6. DIGITAL METER:** Provides the user with an indication of the percentage of available power.

TABLE OF CONTENTS - ACCESSORIES -

Accessories.....Section C
 Factory Installed Options/Accessories.....C-2
 Field Installed Options/AccessoriesC-2

Return to Master TOC

Return to Master TOC

Return to Master TOC

Return to Master TOC

ACCESSORIES

FACTORY INSTALLED OPTIONS / ACCESSORIES

There are no factory installed options.

FIELD INSTALLED OPTIONS / ACCESSORIES

- K1735-1 Multi-Weld 350, Multi-process controller.
- K857, K857-1 Remote control, Control multi-weld remotely (25 or 100 ft.)
- K1736-1 Distribution box, Connects up to 10 Multi-Welds.
- K449 LN-25, Across the arc wire feeder.
- K1788-1 Roll Cage, Protect power source, facilitate moving, store cable.
- K1806-1 Multi-Weld Four pack, Mounting / lift rack for M-S and four M-Ws.
- K1807-1 Multi-Weld Eight Pack, Mounting / lift rack for M-S and eight M-Ws.
- S20428 Paralleling Kit, Allows two machines to equally share double load.

[Return to Section TOC](#) / [Return to Section TOC](#) / [Return to Section TOC](#) / [Return to Section TOC](#)
[Return to Master TOC](#) / [Return to Master TOC](#) / [Return to Master TOC](#) / [Return to Master TOC](#)

TABLE OF CONTENTS

-MAINTENANCE-

Maintenance	Section D
Safety Precautions.....	D-2
Routine and Periodic Maintenance	D-2
Major Component Locations	D-3

Return to Section TOC

Return to Section TOC

Return to Section TOC

Return to Section TOC

Return to Master TOC

Return to Master TOC

Return to Master TOC

Return to Master TOC

MAINTENANCE

SAFETY PRECAUTIONS

WARNING



ELECTRIC SHOCK can kill.

- Only qualified personnel should perform this maintenance.
- Turn the input power **OFF** at the disconnect switch or fuse box before working on this equipment.
- Do not touch electrically charged hot parts.

ROUTINE AND PERIODIC MAINTENANCE

1. Disconnect input AC power supply lines to the machine before performing periodic maintenance, tightening, cleaning, or replacing parts. **See Figure D.1.**

Perform the following daily:

1. Check that no combustible materials are in the welding or cutting area around the machine.
2. Remove the debris, dust, dirt, or materials that could block the air flow to the machine for cooling.
3. Inspect the welding cables for any splits or punctures in the cable jacket, or any condition that would affect the proper operation of the machine.

Perform Periodically:

Clean the inside of the machine with low pressure air stream. Clean the following parts. Refer to **Figure D.1.**

- Main Transformer.
- Electrode and Work Cable connections.
- SCR rectifier bridge and heat sink fins.
- Control Board.
- Firing Board.
- Fan Assembly.

NOTE: The fan motor has sealed bearings which require no maintenance.

MAINTENANCE

FIGURE D.1 – MAJOR COMPONENT LOCATION

- 1. Case Front Assembly
- 2. Case back Assembly
- 3. Fan
- 4. Base
- 5. Sides
- 6. Roof
- 7. Rectifier Assembly

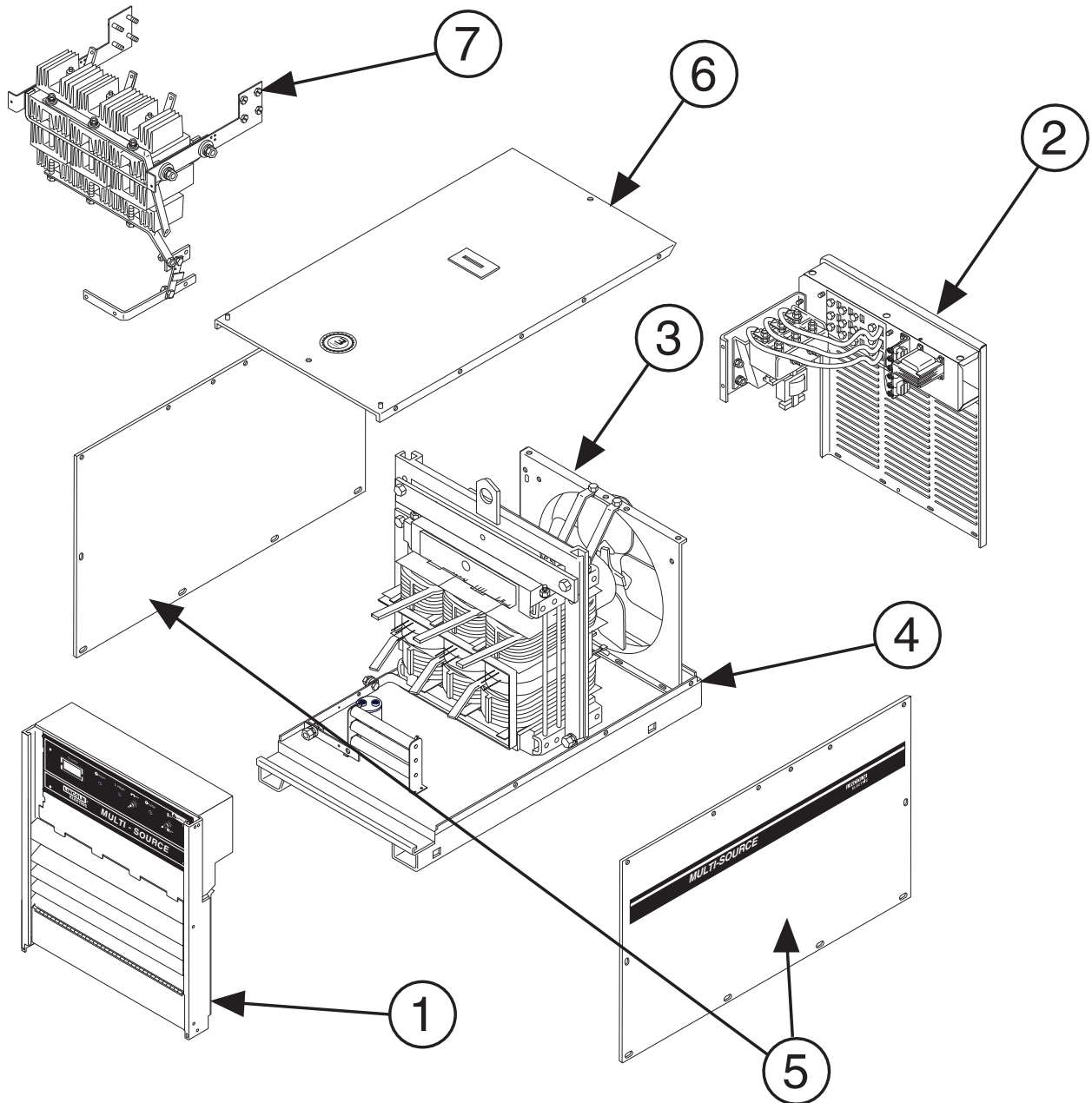

Return to Section TOC
Return to Master TOC

Return to Section TOC
Return to Master TOC

Return to Section TOC
Return to Master TOC

Return to Section TOC
Return to Master TOC

Return to Section TOC
Return to Master TOC

Return to Section TOC
Return to Master TOC

Return to Section TOC
Return to Master TOC

Return to Section TOC
Return to Master TOC

TABLE OF CONTENTS -THEORY OF OPERATION-

Theory of Operation Section	Section E
General Description.....	E-2
Input Voltage, Filter, Contactor and Control Transformer	E-2
Main Transformer, Control Board, Cooling Fan Motor, Digital Meter & LED's	E-3
SCR Bridge, Resistor Bank, Firing Board, & Output Capacitor/Resistor	E-4
Protection Devices & Circuits.....	E-5
SCR Operation	E-6

FIGURE E.1 – MULTI-SOURCE BLOCK LOGIC DIAGRAM

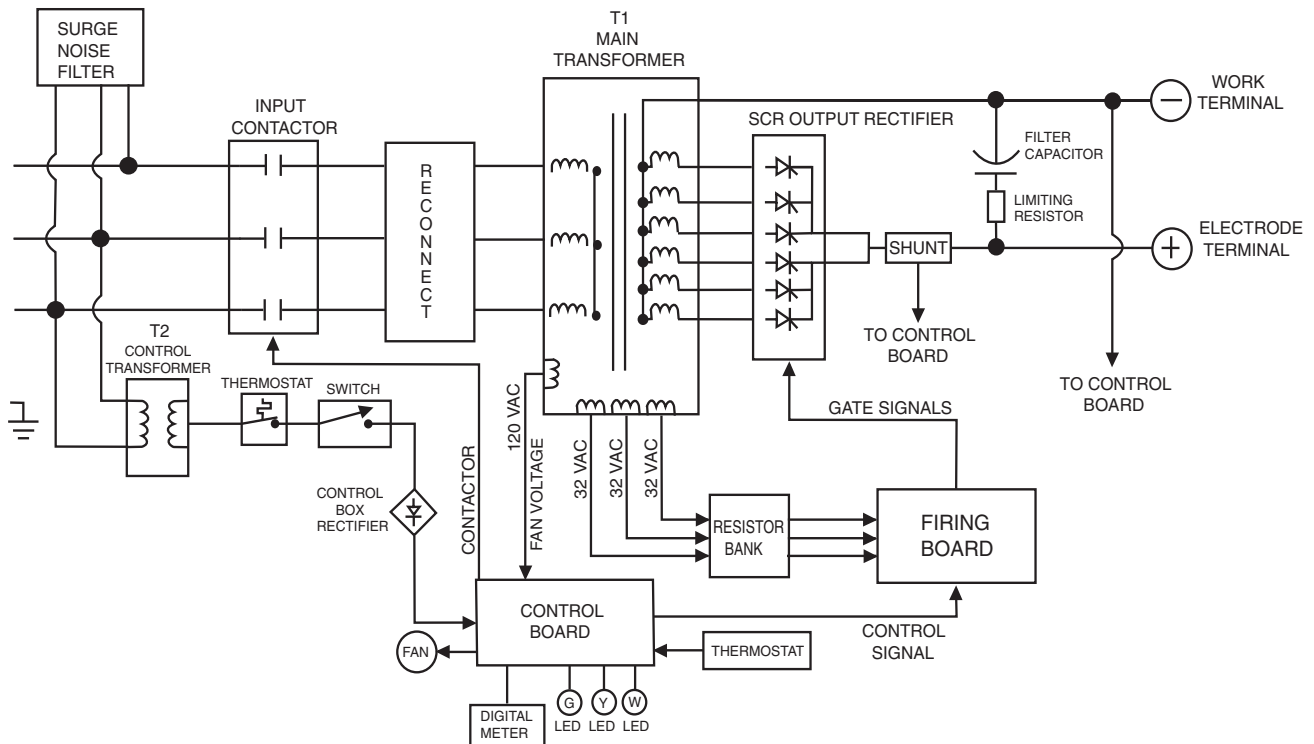

THEORY OF OPERATION

FIGURE E.2 – INPUT VOLTAGE CIRCUIT

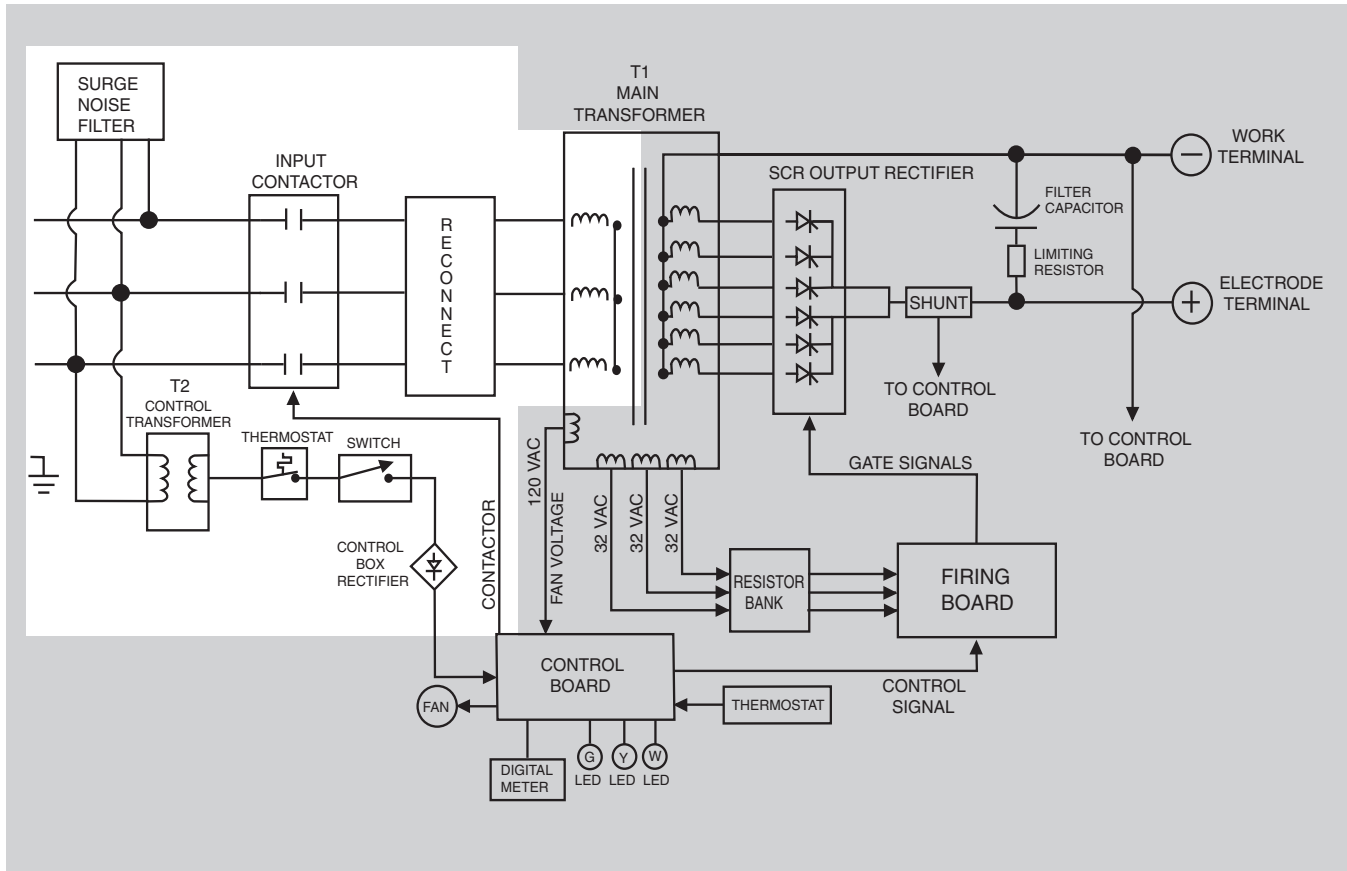

GENERAL DESCRIPTION

The Multi-Source is designed to supply power to the Multi-Weld Arc Converter welders. The Multi-Source is an SCR controlled constant voltage (CV) DC power supply that can operate with a wide range of three phase input voltages. The machine's peak output voltage helps regulate against wide variations in output loading and/or variations in input line voltages. This ability provides for a consistently high stable voltage applied to the Multi-Welds so as to provide good manual electrode welding capability.

INPUT VOLTAGE, FILTER, CONTACTOR AND CONTROL TRANSFORMER

The desired three phase power is connected to the Multi-Source via a reconnect panel located in the input box at the rear of the machine. The reconnect panel allows the user to configure the machine for the desired input voltage. The three phase input power is also applied to a filter assembly that is located in the input box. Two phases of the input voltage are applied to the T2 control transformer. The control transformer

has a single primary-to-secondary ratio (no taps) that spans the full input range up to 600VAC. The secondary voltage developed on the secondary of the control transformer is applied to the control box full wave bridge rectifier via a thermostat and the input power switch. The input contactor, which is activated and controlled by the control board, applies the three phase AC input voltage to the primary windings of the T1 main transformer.

NOTE: Unshaded areas of Block Logic Diagram are the subject of discussion.

FIGURE E.3 – MAIN TRANSFORMER, CONTROL BOARD, COOLING FAN MOTOR, & LEDs

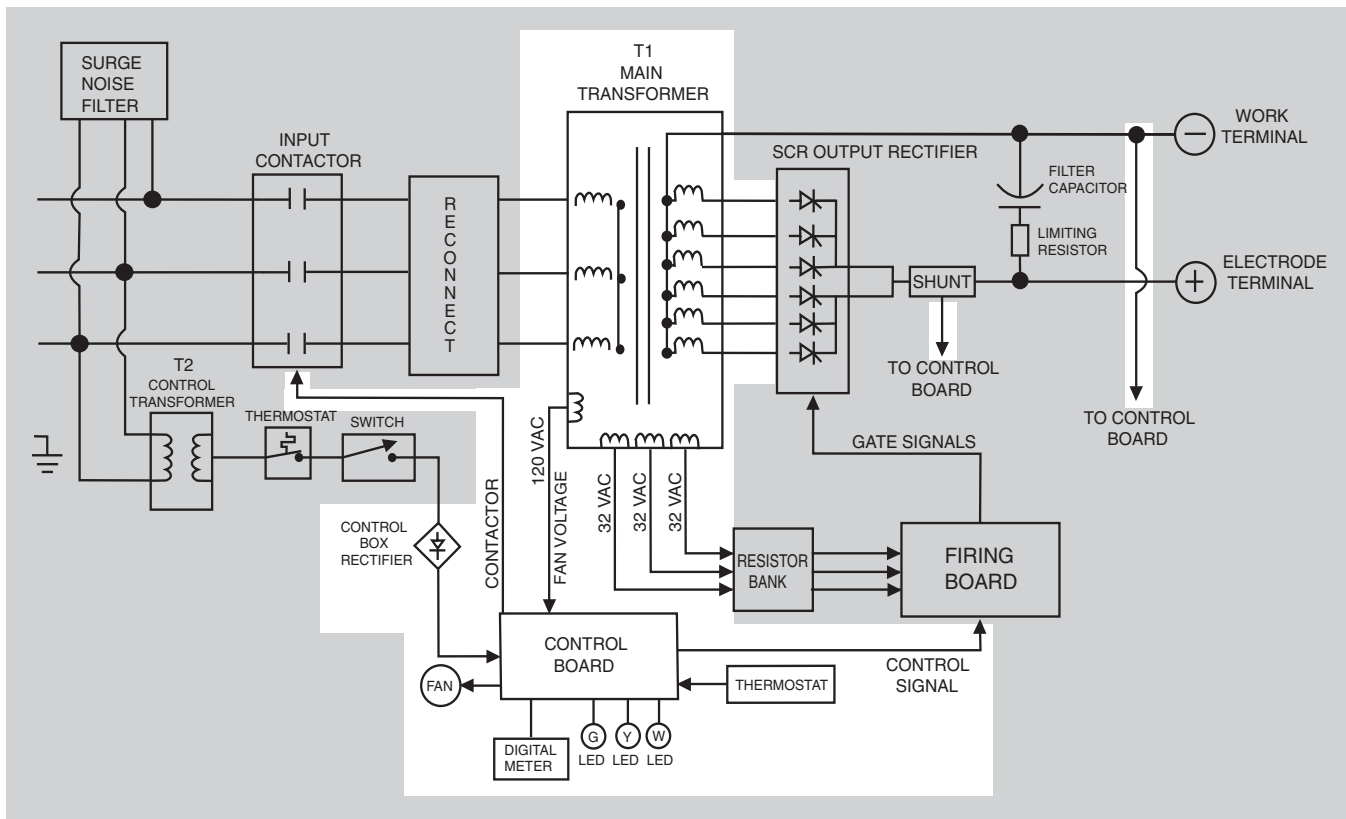

MAIN TRANSFORMER, CONTROL BOARD, COOLING FAN MOTOR, DIGITAL METER AND INDICATOR LIGHTS (LEDs)

The main transformer changes the high voltage, low current input power to a lower voltage, higher current output. The finishes or "neutrals" of the main secondary coils are connected together and the six starts of the secondary windings are connected to the SCR output rectifier assembly. In addition the main transformer has an isolated 120VAC (nominal) winding the supplies 120VAC, via the control board, to operate the cooling fan motor. The three isolated 32VAC (nominal) phase angle windings are also housed in the main transformer assembly. These windings provide power and "timing" information to the firing board.

The control board receives a widely-varying DC voltage from the control box rectifier. The switching power supplies, that are housed on the control board, supply DC current to the control circuits and the input contactor. The control board receives current feedback information from the output shunt, voltage feedback information from the output terminals and temperature information from several thermostats. This feedback information is processed by the control board. The control board then sends the appropriate gate firing signals to the firing board, output information to the digital meter and command signals to the

cooling fan motor and the input contactor.

The cooling fan is controlled by the control board. The F.A.N. (fan as needed) will be activated with an output current greater than 20 amps. It can also be activated (via the control board) by a thermostat located on the main transformer iron.

A current sensing circuit on the control board controls the digital meter display. This meter provides the user with an indication of the percentage of available power that is being drawn from the Multi-Source.

There are three indicator lights located on the front panel of the Multi-Source. The green safe output light indicates when the machine's output voltage is within the safe operating range. Other indicator lights include the amber thermal light that indicates the thermostat, located on the negative output lead, has opened due to an over temperature condition. The white power light indicates when the control board is energized.

FIGURE E.4 – SCR BRIDGE, RESISTOR BANK, FIRING BOARD, & OUTPUT CAPACITOR/RESISTOR

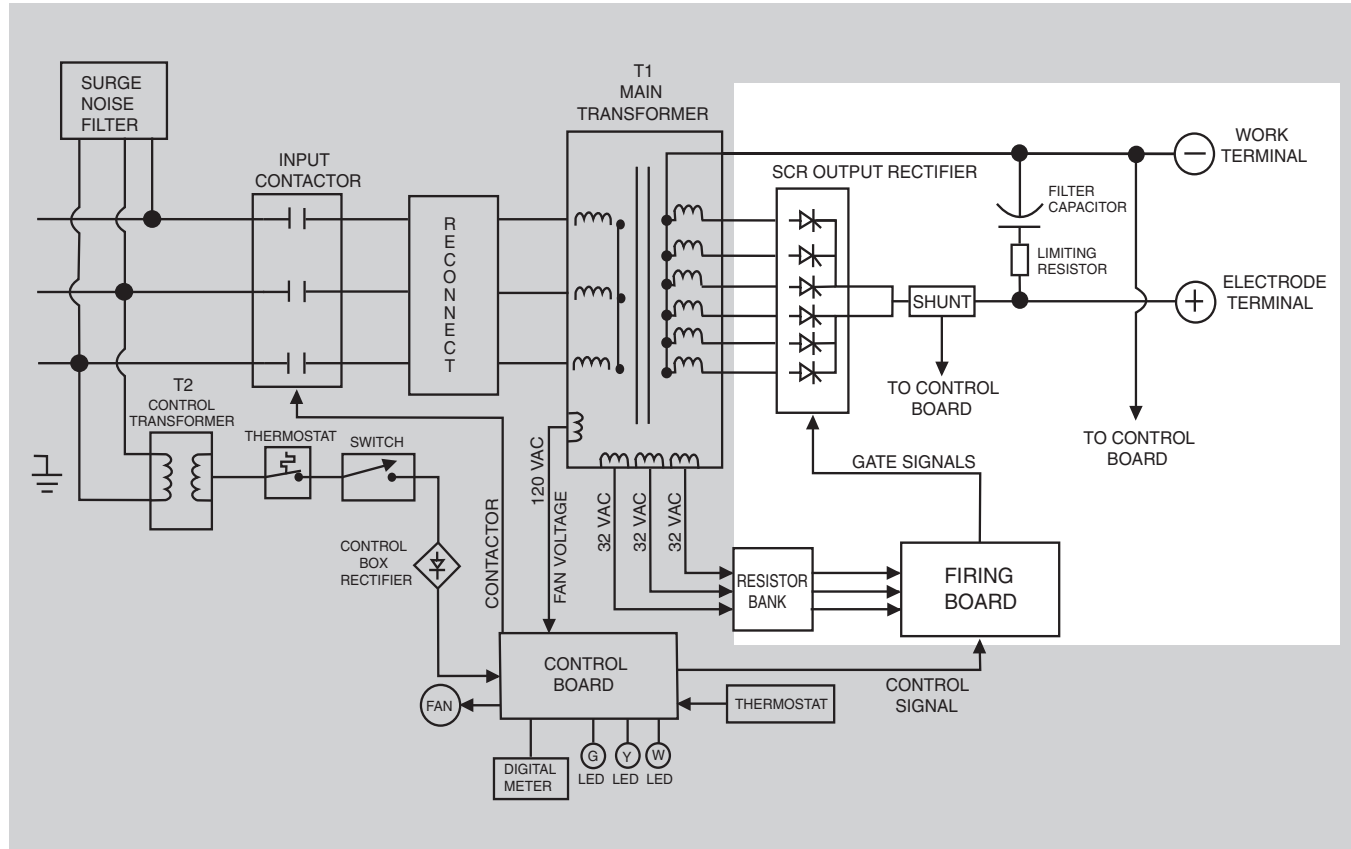

SCR BRIDGE, RESISTOR BANK, FIRING BOARD, AND OUTPUT CAPACITOR/RESISTOR

The neutrals of the main transformer secondary windings are connected together and the six starts are connected to the six SCR assemblies to form a six phase output. This six phase AC output is rectified and controlled through the SCR bridge.

The firing board receives power through the current limiting resistor bank. The firing board is a three phase circuit. Each phase provides two firing pulses; one for each of the two Silicon Controlled Rectifiers (SCRs) controlled by that particular phase. The firing circuit supplies the proper amount of energy to the gates of the power SCRs. When the gate signal is applied, at the correct time, the SCR will turn on and conduct current. The amount of "ON" timer versus "OFF" time determines the output of the machine. See **SCR Operation**.

A capacitor filter and resistor are connected across the output leads on the Multi-Source. This is required to reduce and limit the output voltage peaks. The capacitor ripple current (greatest with light resistive loads) is limited by the resistor.

PROTECTION DEVICES AND CIRCUITS

Several thermostats protect the Multi-Source from over temperature and /or excessive loading. High transformer watts could cause the main transformer to over heat so the cooling fan is activated if a thermostat, located on the front of the main transformer iron, should open.

Two additional thermostats (connected in series) protect the machine in case of fan failure or blocked air-flow at normal output loads. The opening of either the secondary or SCR heat sink thermostat(s) will disable the machine's output and cause the amber thermal light to glow.

The thermostat, located at the rear of the main transformer iron, senses the lamination temperature (and thus the coil insulation temperature) and will interrupt power to the control board causing the input contactor to open until the iron cools.

A 10 amp circuit breaker protects the 120VAC fan circuit. This is located on the front panel of the machine and may be reset if tripped.

An independent safety circuit on the control board monitors the output voltage peaks and opens the input contactor if the upper limit is exceeded for over 300 ms.

If the output current of the machine should exceed the set limitations the control board will disable output for about 75 seconds.

Return to Section TOC
Return to Master TOC
Return to Section TOC
Return to Master TOC
Return to Section TOC
Return to Master TOC
Return to Section TOC
Return to Master TOC

FIGURE E.5 SCR OPERATION

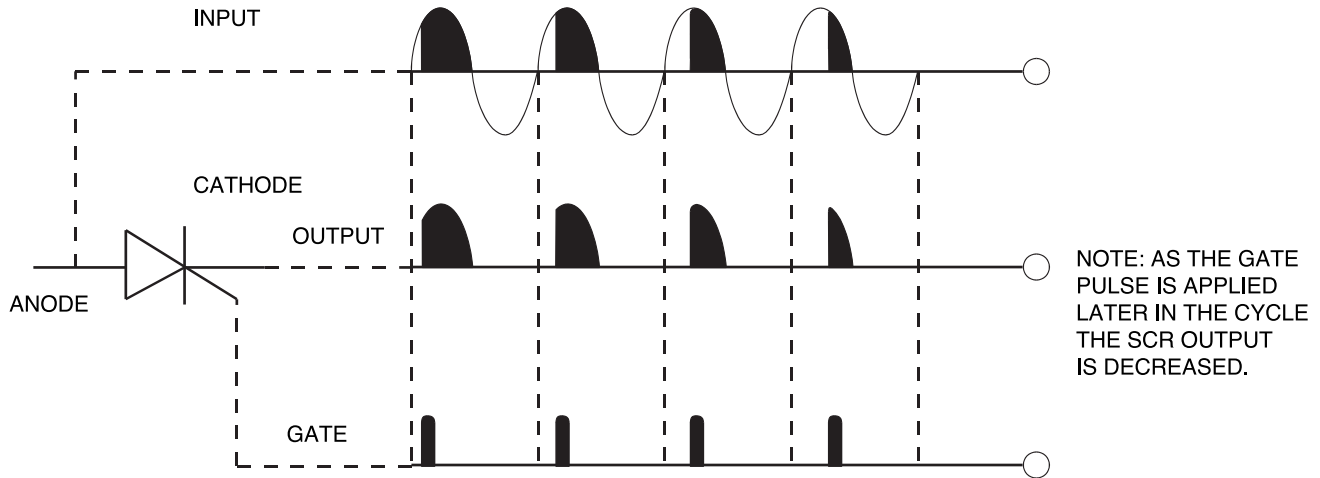

SCR OPERATION

A silicon controlled rectifier (SCR) is a three terminal device used to control rather large currents to a load. An SCR acts very much like a switch. When a gate signal is applied to the SCR it is turned ON and there is current flow from anode to cathode. In the ON state the SCR acts like a closed switch. When the SCR is turned OFF there is no current flow from anode to cathode thus the device acts like an open switch. As the name suggests, the SCR is a rectifier, so it passes current only during positive half cycles of the AC supply. The positive half cycle is the portion of the sine wave in which the anode of the SCR is more positive than the cathode.

When an AC supply voltage is applied to the SCR, the device spends a certain portion of the AC cycle time in the on state and the remainder of the time in the off state. The amount of time spent in the ON state is controlled by the gate.

An SCR is fired by a short burst of current into the gate. This gate pulse must be more positive than the cathode voltage. Since there is a standard PN junction between gate and cathode, the voltage between these terminals must be slightly greater than 0.6V. Once the SCR has fired, it is not necessary to continue the flow of gate current. As long as current continues to flow from anode to cathode the SCR will remain on. When the anode to cathode current drops below a minimum value, called holding current, the SCR will shut off. This normally occurs as the AC supply voltage passes through zero into the negative portion of the sine wave. If the SCR is turned on early in the positive half cycle, the conduction time is longer resulting in greater SCR output. If the gate firing occurs later in the cycle the conduction time is less resulting in lower SCR output.

TABLE OF CONTENTS

-TROUBLESHOOTING & REPAIR SECTION-

Troubleshooting & Repair Section.....	Section F
How to Use Troubleshooting Guide.....	F-2
PC Board Troubleshooting Procedures and Replacement.....	F-3
Troubleshooting Guide	F-4
Test Procedures	F-9
Control Transformer (T2) Test	F-9
Input Contactor Test.....	F-13
Main Transformer (T1) Voltage Test	F-17
Static SCR Test.....	F-21
Active SCR Test.....	F-25
Control Board Test.....	F-31
Firing Board Test.....	F-35
Multi-Source Meter Accuracy Test	F-39
Normal Open Circuit Voltage Waveform - No Load	F-41
Abnormal Open Circuit Voltage Waveform 1 SCR Not Functioning - No Load.....	F-42
Typical SCR Gate Voltage Waveform - No Load.....	F-43
Replacement Procedures.....	F-45
Input Contactor Cleaning and/or Replacement	F-45
Control Board Removal and Replacement.....	F-49
Firing Board Removal and Replacement.....	F-51
SCR Bridge/Heat Sink Assembly Removal and Replacement.....	F-53
Retest After Repair	F-59

Return to Master TOC

Return to Master TOC

Return to Master TOC

Return to Master TOC

TROUBLESHOOTING & REPAIR

HOW TO USE TROUBLESHOOTING GUIDE

WARNING

Service and repair should be performed by only Lincoln Electric Factory Trained Personnel. Unauthorized repairs performed on this equipment may result in danger to the technician and machine operator and will invalidate your factory warranty. For your safety and to avoid Electrical Shock, please observe all safety notes and precautions detailed throughout this manual.

This Troubleshooting Guide is provided to help you locate and repair possible machine malfunctions. Simply follow the three-step procedure listed below.

Step 1. LOCATE PROBLEM (SYMPTOM). Look under the column labeled “PROBLEM (SYMPTOMS). This column describes possible symptoms that the machine may exhibit. Find the listing that best describes the symptom that the machine is exhibiting. Symptoms are grouped into two main categories: Output Problems and Function Problems.

Step 2. PERFORM EXTERNAL TESTS. The second column, labeled “POSSIBLE AREAS OF MISADJUSTMENT(S),” lists the obvious external possibilities that may contribute to the machine symptom. Perform these tests/checks in the order listed. In general, these tests can be conducted without removing the case wrap-around cover.

Step 3. PERFORM COMPONENT TESTS. The last column, labeled “Recommended Course of Action,” lists the most likely components that may have failed in your machine. It also specifies the appropriate test procedure to verify that the subject component is either good or bad. If there are a number of possible components, check the components in the order listed to eliminate one possibility at a time until you locate the cause of your problem.

All of the referenced test procedures referred to in the Troubleshooting Guide are described in detail at the end of this chapter. Refer to the Troubleshooting and Repair Table of Contents to locate each specific Test Procedure. All of the referred to test points, components, terminal strips, etc., can be found on the referenced electrical wiring diagrams and schematics. Refer to the Electrical Diagrams Section Table of Contents to locate the appropriate diagram.

CAUTION

If for any reason you do not understand the test procedures or are unable to perform the test/repairs safely, contact the Lincoln Electric Service Department for electrical troubleshooting assistance before you proceed. Call 1-888-935-3877.

PC BOARD TROUBLESHOOTING PROCEDURES AND REPLACEMENT

**WARNING****ELECTRIC SHOCK can kill.**

Have an electrician install and service this equipment. Turn the machine OFF before working on equipment. Do not touch electrically hot parts.

Sometimes machine failures appear to be due to PC board failures. These problems can sometimes be traced to poor electrical connections. To avoid problems when troubleshooting and replacing PC boards, please use the following procedure:

1. Determine to the best of your technical ability that the PC board is the most likely component causing the failure symptom.
2. Check for loose connections at the PC board to assure that the PC board is properly connected.
3. If the problem persists, replace the suspect PC board using standard practices to avoid static electrical damage and electrical shock. Read the warning inside the static resistant bag and perform the following procedures.



ATTENTION
Static-Sensitive
Devices
Handle only at
Static-Safe
Workstations

**Reusable
Container
Do Not Destroy**

PC Board can be damaged by static electricity.

- Remove your body's static charge before opening the static-shielding bag. Wear an anti-static wrist strap. For safety, use a 1 Meg ohm resistive cord connected to a grounded part of the equipment frame.
 - If you don't have a wrist strap, touch an unpainted, grounded, part of the equipment frame. Keep touching the frame to prevent static build-up. Be sure not to touch any electrically live parts at the same time.
- Tools which come in contact with the PC Board must be either conductive, anti-static or static-dissipative.

- Remove the PC Board from the static-shielding bag and place it directly into the equipment. Don't set the PC Board on or near paper, plastic or cloth which could have a static charge. If the PC Board can't be installed immediately, put it back in the static-shielding bag.
 - If the PC Board uses protective shorting jumpers, don't remove them until installation is complete.
 - If you return a PC Board to The Lincoln Electric Company for credit, it must be in the static-shielding bag. This will prevent further damage and allow proper failure analysis.
4. Perform any necessary PC Board calibration procedures. See the flow chart on the next page.
 5. Test the machine to determine if the failure symptom has been corrected by the replacement PC board.

NOTE: Allow the machine to heat up so that all electrical components can reach their operating temperature.

6. Remove the replacement PC board and substitute it with the original PC board to recreate the original problem. Recalibrate if required.
 - a. If the original problem does not reappear by substituting the original board, then the PC board was not the problem. Continue to look for bad connections in the control wiring harness, junction blocks, and terminal strips.
 - b. If the original problem is recreated by the substitution of the original board, then the PC board was the problem. Reinstall the replacement PC board, recalibrate if required, and test the machine.
7. Always indicate that this procedure was followed when warranty reports are to be submitted.

NOTE: Following this procedure and write on the warranty report, "INSTALLED AND SWITCHED PC BOARDS TO VERIFY PROBLEM," will help avoid denial of legitimate PC board warranty claims.

TROUBLESHOOTING & REPAIR

TROUBLESHOOTING GUIDE

Observe Safety Guidelines detailed in the beginning of this manual.

OUTPUT PROBLEMS (SYMPTOMS)	POSSIBLE AREAS OF MISADJUSTMENT(S)	RECOMMENDED COURSE OF ACTION
OUTPUT PROBLEMS		
Major physical or electrical damage is evident.	<ol style="list-style-type: none"> 1. Contact the Lincoln Electric Service Dept. 1-888-935-3877 	<ol style="list-style-type: none"> 1. Contact the Lincoln Electric Service Dept. 1-888-935-3877
Machine Multi-Source is dead and the input contactor does not operate. The white power light is NOT lit.	<ol style="list-style-type: none"> 1. Check for blown or missing fuses in the input lines. 2. Check the three phase input line voltage at the Multi-Source. The input voltage must match the rating plate and reconnect panel. 	<ol style="list-style-type: none"> 1. The ON/OFF switch may be faulty. Check switch and associated leads. See the Wiring Diagram. 2. The thermostat, located on the rear of the main transformer iron, may be faulty. This is normally a closed device. 3. The control box diode bridge may be faulty. Also check associated wiring for loose or faulty connections. See the Wiring Diagram. 4. Perform the T2 Control Transformer Test. 5. Perform the Control Board Test.
The input contactor does not operate. The white power light is ON.	<ol style="list-style-type: none"> 1. Check the three phase input line voltage at the Multi-Source. The input line voltage must match the rating plate and reconnect panel. 2. Turn the power switch OFF and wait a few seconds. Turn the power switch back ON. If the problem is not resolved, continue with the "Recommended Courses of Action". 	<ol style="list-style-type: none"> 1. Perform the Input Contactor Test. 2. Check leads #240 and #241 between the control board and the input contactor for loose or faulty connections. See the Wiring Diagram. 3. Perform the Control Board Test. 4. Perform the SCR Rectifier Bridge Test.

CAUTION

If for any reason you do not understand the test procedures or are unable to perform the test/repairs safely, contact the Lincoln Electric Service Department for electrical troubleshooting assistance before you proceed. Call 1-888-935-3877.

Return to Section TOC
Return to Master TOC

TROUBLESHOOTING & REPAIR

TROUBLESHOOTING GUIDE

Observe Safety Guidelines detailed in the beginning of this manual.

OUTPUT PROBLEMS (SYMPTOMS)	POSSIBLE AREAS OF MISADJUSTMENT(S)	RECOMMENDED COURSE OF ACTION
OUTPUT PROBLEMS		
<p>The white power light is lit and the input contactor activates but there is no welding output. The amber thermal light is NOT lit.</p>	<ol style="list-style-type: none"> 1. Check the welding cables for loose or faulty connections. 2. Make certain the Multi-Weld(s) are connected and operating properly. 3. Check (at the output terminals of the Multi-Source) for approximately 75-80VDC open circuit voltage. If this voltage is present, the problem is most likely external to the Multi-Source machine. 	<ol style="list-style-type: none"> 1. Perform the Firing Board Test. 2. Perform the Control Board Test. 3. Perform the SCR Rectifier Bridge Test. 4. Perform the Main Transformer (T1) Test. 5. Perform the Input Contactor Test.
<p>The Multi-Source operates but does NOT have maximum welding output. 40,000 watts on 60 Hz - 36,000 watts on 50HZ.</p>	<ol style="list-style-type: none"> 1. Check all three phases of the input voltage at the Multi-Source machine. Make sure the input voltages are present and match the machine's rating and reconnect panel configuration. 2. Check for loose or faulty welding cables. 	<ol style="list-style-type: none"> 1. Perform the Main Transformer (T1) Test. 2. Perform the SCR Rectifier Bridge Test. 3. Perform the Input Contactor Test. 4. Perform the Firing Board Test. 5. Perform the Control Board Test. 6. The output shunt may be faulty. See Display Calibration Procedure.

 **CAUTION**

If for any reason you do not understand the test procedures or are unable to perform the test/repairs safely, contact the Lincoln Electric Service Department for electrical troubleshooting assistance before you proceed. Call 1-888-935-3877.

Return to Section TOC
Return to Master TOC

TROUBLESHOOTING & REPAIR

TROUBLESHOOTING GUIDE

Observe Safety Guidelines detailed in the beginning of this manual.

OUTPUT PROBLEMS (SYMPTOMS)	POSSIBLE AREAS OF MISADJUSTMENT(S)	RECOMMENDED COURSE OF ACTION
OUTPUT PROBLEMS		
<p>The Multi-Source has only momentary output after the input contactor activates. Output returns momentarily approximately every 75 seconds.</p>	<ol style="list-style-type: none"> 1. Remove all external welding cables from the Multi-Source machine. If the open circuit voltage (75-80VDC) is present and constant at the output terminals there may be a short circuit external to the Multi-Source. Check the welding cables and the Multi-Weld machines. 2. If the problem is not resolved with the welding cables removed, there is a fault within the Multi-Source machine. 	<ol style="list-style-type: none"> 1. Check all heavy current carrying leads within the Multi-Source for possible “shorting” conditions. See the Wiring Diagram. 2. Perform the SCR Rectifier Bridge Test. 3. Perform the Control Board Test.
<p>The Multi-Source has momentary output only. The green light is OFF and the input contactor opens.</p>	<ol style="list-style-type: none"> 1. Check the three phase input voltage. Make certain it is not too high for the machine’s rating and the reconnect panel configuration. 	<ol style="list-style-type: none"> 1. Check the output filter circuit. (resistor R9, capacitor C3, and leads 222C, 292, 294B. See the Wiring Diagram. 2. Check the voltage feedback leads 215B and 222A for loose or faulty connections. See the Wiring Diagram. 3. Perform the SCR Rectifier Bridge Test. 4. Perform the Control Board Test.

CAUTION

If for any reason you do not understand the test procedures or are unable to perform the test/repairs safely, contact the Lincoln Electric Service Department for electrical troubleshooting assistance before you proceed. Call 1-888-935-3877.



Return to Section TOC

Return to Section TOC

Return to Section TOC

Return to Section TOC

Return to Master TOC

Return to Master TOC

Return to Master TOC

Return to Master TOC

TROUBLESHOOTING & REPAIR

TROUBLESHOOTING GUIDE

Observe Safety Guidelines detailed in the beginning of this manual.

OUTPUT PROBLEMS (SYMPTOMS)	POSSIBLE AREAS OF MISADJUSTMENT(S)	RECOMMENDED COURSE OF ACTION
OUTPUT PROBLEMS		
<p>The amber thermal light is lit. The machine does not have welding output, the fan runs and the digital output display reads a value greater than 100.</p>	<ol style="list-style-type: none"> The machine is being over-loaded and thus overheated. Reduce the load to conform to the rated output limits of the Multi-Source machine. See the Technical Specifications. 	
<p>The amber thermal light is lit. The machine does not have welding output, and the fan runs. The digital output display reads a value greater than 100.</p>	<ol style="list-style-type: none"> The machine may be internally clogged with dirt and dust. Clean the machine with clean dry compressed air. The cooling vents may be obstructed or blocked. The ambient cooling air may be too hot. 	<ol style="list-style-type: none"> The secondary lead thermostat or SCR heat sink thermostat may be faulty. Check and replace if necessary. These are normally closed devices. Also check associated leads for loose or faulty connections. See the Wiring diagram. The control board may be faulty.
<p>The amber thermal light is lit. The machine does not have welding output, the fan does NOT run and the digital output display never reads a value greater than 100.</p>	<ol style="list-style-type: none"> Check the fan circuit breaker located on the front panel. Reset if tripped 	<ol style="list-style-type: none"> The fan motor may be faulty. Disconnect and test using an isolated 120VAC supply. Check the leads #250, #253, and #252 between the fan motor, the circuit breaker and the control board. See the Wiring Diagram. Make certain the 120VAC fan voltage is being developed by the main transformer. See the Main Transformer Test. Make sure the shunt and the output display are operating properly. See Display Calibration Procedure.



If for any reason you do not understand the test procedures or are unable to perform the test/repairs safely, contact the Lincoln Electric Service Department for electrical troubleshooting assistance before you proceed. Call 1-888-935-3877.

Return to Section TOC
Return to Section TOC
Return to Section TOC
Return to Section TOC
Return to Section TOC
Return to Section TOC
Return to Section TOC
Return to Section TOC
Return to Section TOC
Return to Section TOC
Return to Master TOC
Return to Master TOC
Return to Master TOC
Return to Master TOC
Return to Master TOC

INSTALLATION

TROUBLESHOOTING GUIDE

Observe Safety Guidelines detailed in the beginning of this manual.

OUTPUT PROBLEMS (SYMPTOMS)	POSSIBLE AREAS OF MISADJUSTMENT(S)	RECOMMENDED COURSE OF ACTION
FUNCTIONS PROBLEMS		
The Multi-Source machine will not shut off when the ON/OFF switch is in the OFF position.	1. Remove all external loading to the Multi-Source and then carefully remove the input power.	1. The ON/OFF power switch may be faulty. See the Wiring Diagram. 2. The input contactor may be stuck closed. Perform the <i>Input Contactor Test</i> .

⚠ CAUTION

If for any reason you do not understand the test procedures or are unable to perform the test/repairs safely, contact the Lincoln Electric Service Department for electrical troubleshooting assistance before you proceed. Call 1-888-935-3877.



Return to Section TOC

Return to Master TOC

CONTROL TRANSFORMER (T2) VOLTAGE TEST**WARNING**

Service and repair should be performed only by Lincoln Electric factory trained personnel. Unauthorized repairs performed on this equipment could result in danger to the technician or the machine operator and will invalidate your factory warranty. For your safety and to avoid electrical shock, please observe all safety notes and precautions detailed throughout this manual.

If for any reason you do not understand the test procedures or are unable to perform the tests/repairs safely, contact the Lincoln Electric Service Department for technical troubleshooting assistance before you proceed. Call 1-888-935-3877.

TEST DESCRIPTION

This test will determine if the correct voltage is being induced on the secondary winding of the control transformer.

MATERIALS NEEDED

Volt/Ohm Meter (Multimeter)

MULTI-SOURCE wiring diagrams (See Electrical Diagram Section of Manual).

3/8" Nut Driver

This procedure takes approximately 30 minutes to perform.

TROUBLESHOOTING & REPAIR

CONTROL TRANSFORMER (T2) VOLTAGE TEST

FIGURE F.1. CONTROL TRANSFORMER LOCATION & LEADS

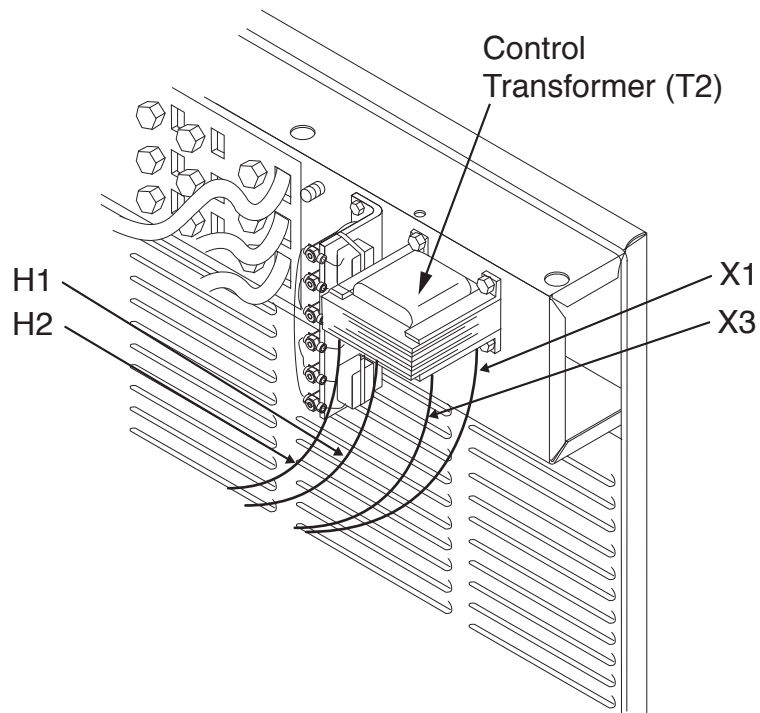

TEST PROCEDURE

1. Disconnect main AC input power to the machine.
2. Remove the Top and Right case side.
3. Locate the Control Transformer (T2) on the left side of the input box (facing the back of the machine). See Figure F.1.
4. Locate the Control Transformer primary leads H1 & H2. See Wiring Diagram. See Figure F.1.
5. Locate control transformer terminals X1 and X3. See Figure F.1.

TROUBLESHOOTING & REPAIR

CONTROL TRANSFORMER (T2) VOLTAGE TEST

- Carefully apply primary power and test for the correct secondary voltages. See Table F.1.

NOTE: If the correct main AC input power to the Control Transformer is present, and the secondary voltages are not correct, the Control Transformer may be faulty. Replace.

TABLE F.1.

Primary H1 & H2 Voltage	Approximate Secondary Voltage X1-X3
575 VAC	43.0 VAC
460 VAC	34.50 VAC
380 VAC	28.50 VAC
Approximate Secondary Resistance (X1-X3)	0.5 Ohms
Approximate Primary Resistance (H1-H2)	60 Ohms
X2-X3 Thermostat	0 Ohms

Return to Section TOC
 Return to Master TOC

Return to Section TOC
 Return to Master TOC

Return to Section TOC
 Return to Master TOC

Return to Section TOC
 Return to Master TOC

CONTROL TRANSFORMER (T2) VOLTAGE TEST

FIGURE F.2. Thermostat

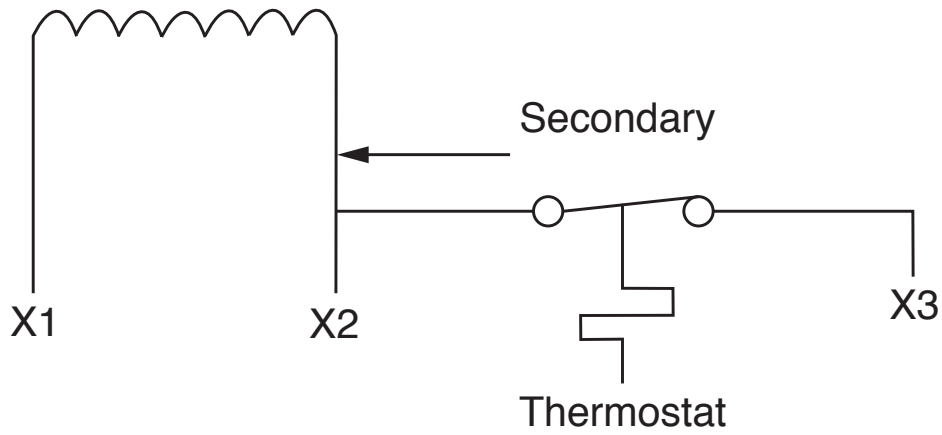

NOTE: If the secondary voltage is not present at terminal #X3 but is present at terminal #X2 the internal thermostat is faulty. See Figure F.2.

7. Replace any leads previously removed.
8. Replace right side and roof.

Return to Section TOC
Return to Master TOC
Return to Section TOC
Return to Master TOC
Return to Section TOC
Return to Master TOC
Return to Section TOC
Return to Master TOC

INPUT CONTACTOR TEST

**WARNING**

Service and repair should be performed only by Lincoln Electric factory trained personnel. Unauthorized repairs performed on this equipment could result in danger to the technician or the machine operator and will invalidate your factory warranty. For your safety and to avoid electrical shock, please observe all safety notes and precautions detailed throughout this manual.

If for any reason you do not understand the test procedures or are unable to perform the tests/repairs safely, contact the Lincoln Electric Service Department for technical troubleshooting assistance before you proceed. Call 1-888-935-3877.

TEST DESCRIPTION

This test will determine if the input contactor is receiving the correct coil voltage and if the contacts are functioning correctly.

MATERIALS NEEDED

Ammeter
MULTI-SOURCE wiring diagrams (See Electrical Diagram Section of Manual).
3/8" Nut Driver
External 120VAC supply

This procedure takes approximately 30 minutes to perform.

TROUBLESHOOTING & REPAIR

INPUT CONTACTOR TEST (Continued)

FIGURE F.3. INPUT CONTACTOR CONNECTIONS

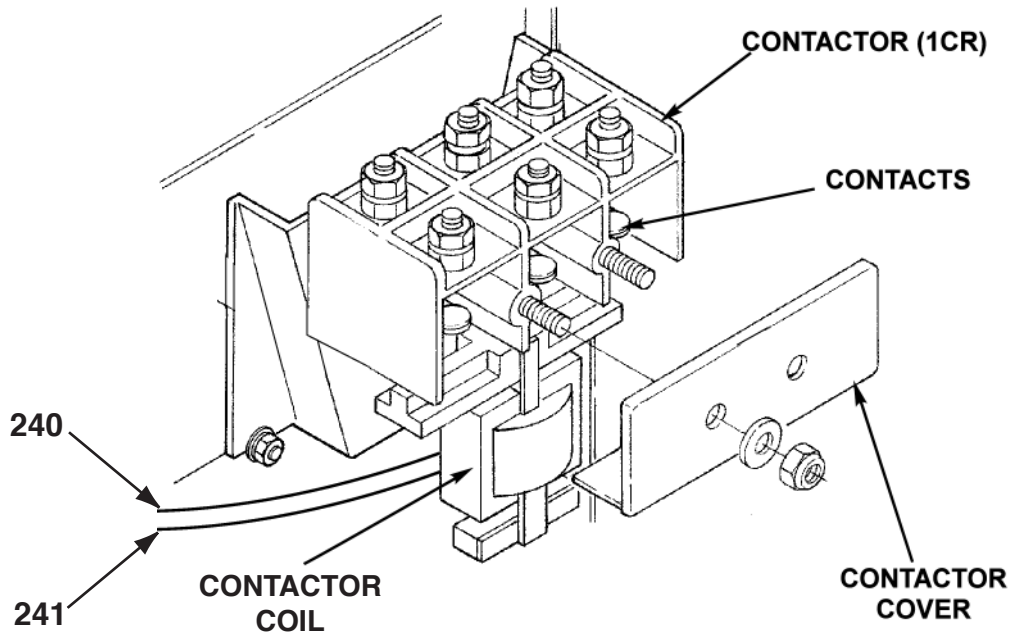

1. Disconnect the main input supply power to the machine.
2. With the 3/8" nut driver, remove the case top and the left case side.
3. Locate the two leads connected to the input contactor coil, #240 and #241. See Figure F.3 for location. Note: The disconnects may be located inside the loom (lead covering).
4. Connect a DC ammeter to either lead #240 or #241.
6. Check for approximately 1 amp of current flow at the contactor coil. This current is supplied by the Control Board. NOTE: The pull-in coil current is designed to be about 5 amps for 100ms occurring about one second after the power switch is closed. Without this current pulse, the contactor will not activate.

If the current is present and the contactor does NOT activate, then the input contactor coil may be faulty, or the contactor's moving parts may be stuck. The normal coil resistance is approximately 4.0 ohms.

If the 1 amp DC current is NOT present, check the continuity of the leads between the contactor and the control board. See the Wiring Diagram.

The contactor may also be tested by disconnecting leads #240 and #241 from the coil and applying an external 120VAC supply to the contactor coil. The contactor should activate.



WARNING



Electric Shock can kill.

- With the input power on, there are high voltages inside the machine. Do not reach into the machine or touch any internal part of the machine while the power is on. High voltage is present at terminals.

5. Carefully apply the correct voltage to the machine and turn the power switch (S1) ON.

TROUBLESHOOTING & REPAIR

INPUT CONTACTOR TEST (Continued)

FIGURE F.4. INPUT CONTACTOR TEST CONNECTIONS

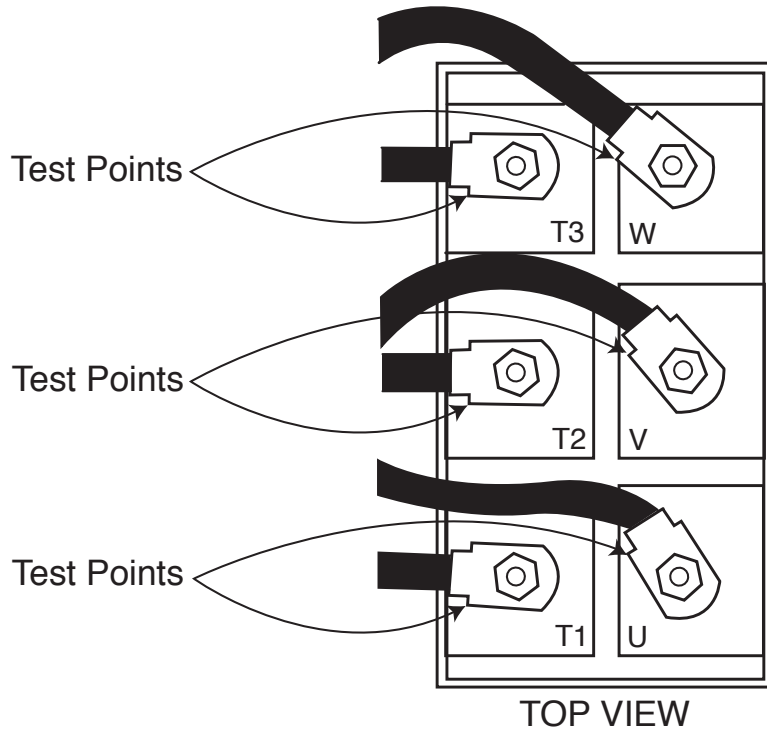

TEST FOR CONTACT CONTINUITY

1. Disconnect the main input supply power to the machine.
2. Remove the two leads connected to the input contactor coil, #240 and #241. See **Figure F.3** for location.
3. Using the external 120VAC supply, apply 120VAC to the leads of the input contactor coil. If the contactor does NOT activate, the input contactor is faulty. Replace the input contactor.
4. With the contactor activated, check the continuity across the contacts. (Zero ohms or very low resistance is normal.) See
5. When the contactor is NOT activated, the resistance should be infinite or very high across the contacts. If the resistance is low, the input contactor is faulty. Replace the input contactor. See **Input Contactor Removal and Replacement Procedure**.
6. Reconnect any leads previously removed. Replace any cable ties and loom previously removed. Replace the roof and left case side.

Figure F.4. If the resistance is high, the input contactor is faulty. Replace the input contactor.

Return to Section TOC
Return to Master TOC

Return to Section TOC
Return to Master TOC

Return to Section TOC
Return to Master TOC

Return to Section TOC
Return to Master TOC



TROUBLESHOOTING & REPAIR

MAIN TRANSFORMER (T1) VOLTAGE TEST



WARNING

Service and repair should be performed only by Lincoln Electric factory trained personnel. Unauthorized repairs performed on this equipment could result in danger to the technician or the machine operator and will invalidate your factory warranty. For your safety and to avoid electrical shock, please observe all safety notes and precautions detailed throughout this manual.

If for any reason you do not understand the test procedures or are unable to perform the tests/repairs safely, contact the Lincoln Electric Service Department for technical troubleshooting assistance before you proceed. Call 1-888-935-3877.

TEST DESCRIPTION

This test will determine if the correct voltages are being:

- a. applied to the primary windings of the Main Transformer (T1).
- b. induced on the secondary windings, fan winding, and phase angle windings.

MATERIALS NEEDED

Volt/Ohm Meter

MULTI-SOURCE wiring diagrams (See Electrical Diagram Section of Manual).

3/8" Nut Driver

This procedure takes approximately 45 minutes to perform.

MAIN TRANSFORMER (T1) VOLTAGE TEST *(continued)*

FIGURE F.5. Input Contactor, Reconnect Panel, and Primary Leads to Main Transformer Locations

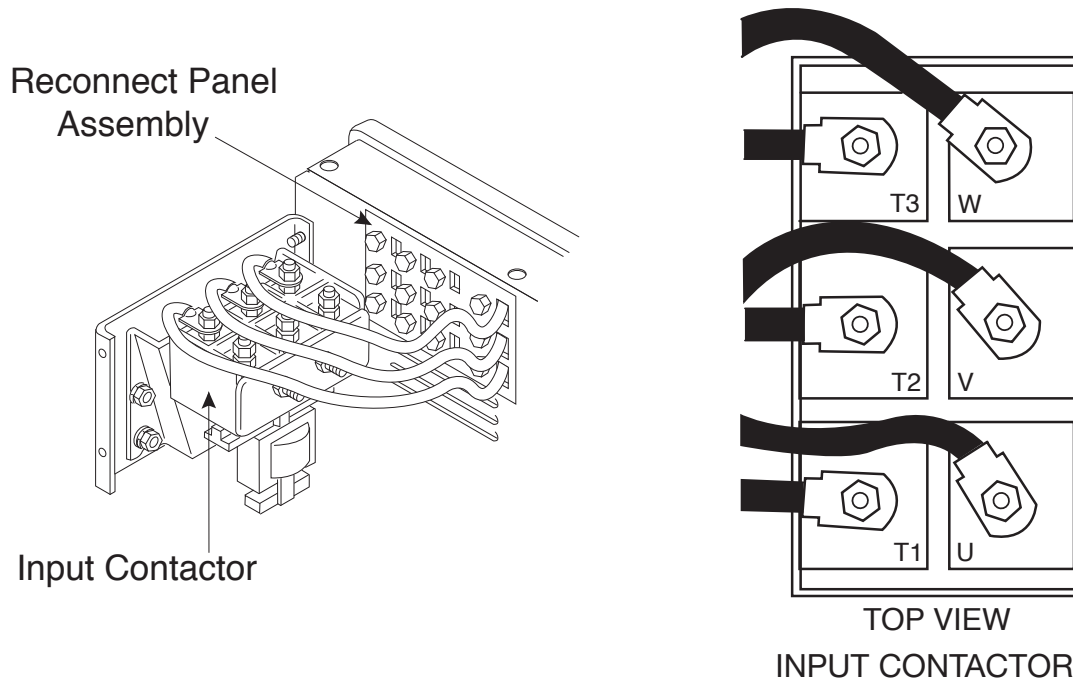

TEST PROCEDURE

1. Disconnect main AC input power to the machine.
2. Using a 3/8" nutdriver, remove roof and sides of case cover.
3. Inspect the input contactor, reconnect panel, and primary leads to the main transformer for loose or faulty connections. See Figure F.5.
4. Carefully apply input power, turn on and make sure the input contactor (1CR) energizes.
5. Carefully test with an AC voltmeter for the proper main AC input voltage to the line side of the input contactor (1CR). See Wiring Diagram. See Figure F.5.

U to V

V to W

U to W

NOTE: If proper voltage is not present in any or all of the three phases, check input fuses and leads.

5. Test with an AC voltmeter for proper main AC input voltage from the output side of

the input contactor (1CR). See Wiring Diagram. See Figure F.5.

T1 to T2

T2 to T3

T1 to T3

- a. If the correct voltage is present, the contactor is working properly.
 - b. If the correct voltage is not present for any or all of the three phases, the contactor may be faulty. See **Input Contactor Test**.
6. Test with an AC voltmeter for approximately 97 VAC from each of the six main transformer secondary leads to the common buss connected to the negative output terminal. **See Figure F.6.**
 - a. If one or more of the above voltage tests are incorrect, check for loose or faulty wiring. If the wiring is good, then the main transformer may be faulty.

NOTE: A long wire with a clip or a long probe may be required to reach the lower middle lead.

MAIN TRANSFORMER (T1) VOLTAGE TEST *(continued)*

FIGURE F.6. Main Secondary Lead Test Points

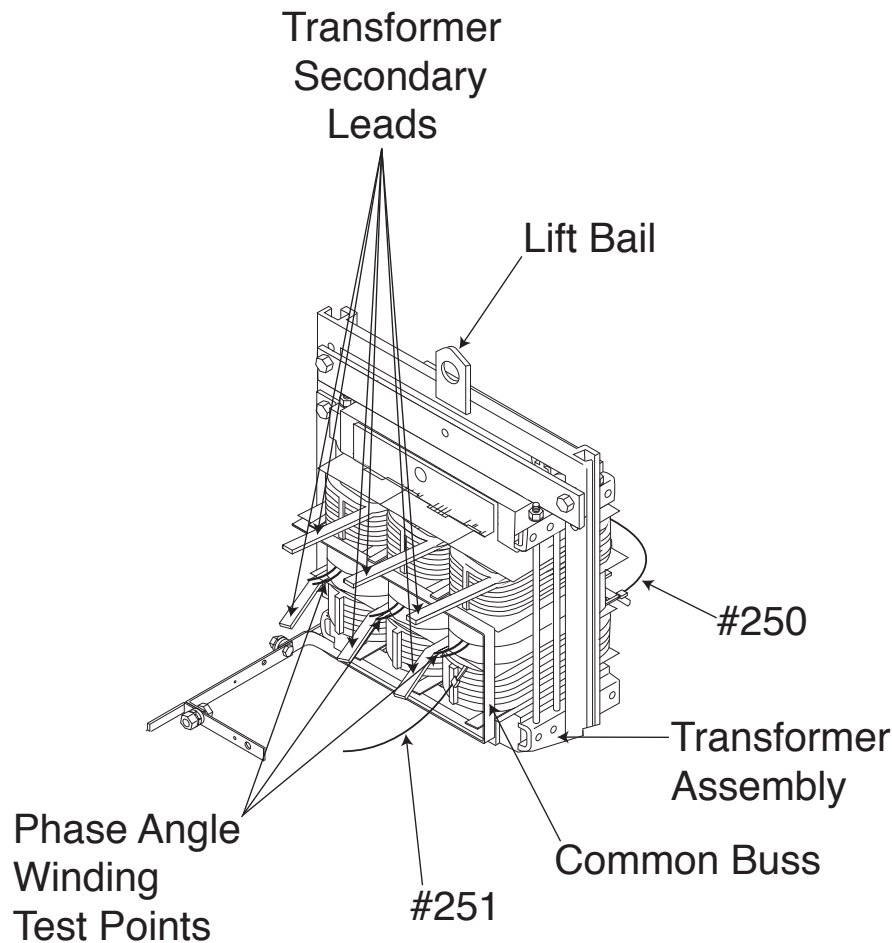

7. Test for 120 VAC between leads #250 to #251. See Figure F.6. See Wiring Diagram.
 - a. If the 120 VAC is not present, check for loose or faulty wiring. If necessary, untape and track the continuity of leads #250 and #251 through the entire harness. See the Wiring Diagram.
 - b. If the wiring is good and the 120 VAC is not present, then the main transformer may be faulty.
9. Test with an AC voltmeter for 32 VAC for each phase angle winding as shown. See Figure F.6. See Wiring Diagram.

NOTE: If the main supply voltage varies, the Main Transformer voltages will vary proportionately.
10. Be sure to replace any and all insulation materials that were removed for testing purposes.
11. Replace roof and sides of case cover.

Return to Section TOC
Return to Master TOC

Return to Section TOC
Return to Master TOC

Return to Section TOC
Return to Master TOC

Return to Section TOC
Return to Master TOC

STATIC SCR TEST



WARNING

Service and repair should be performed only by Lincoln Electric factory trained personnel. Unauthorized repairs performed on this equipment could result in danger to the technician or the machine operator and will invalidate your factory warranty. For your safety and to avoid electrical shock, please observe all safety notes and precautions detailed throughout this manual.

If for any reason you do not understand the test procedures or are unable to perform the tests/repairs safely, contact the Lincoln Electric Service Department for technical troubleshooting assistance before you proceed. Call 1-888-935-3877.

TEST DESCRIPTION

The Static SCR Test is a quick check to determine if an SCR is shorted or “leaky”. See machine waveform section for normal and abnormal output waveforms.

MATERIALS NEEDED

Analog Volt/Ohm Meter (Multimeter)

MULTI-SOURCE wiring diagrams (See Electrical Diagram Section of Manual).

3/8” Nut Driver

9/16” Wrench

This procedure takes approximately 45 minutes to perform.

TROUBLESHOOTING & REPAIR

STATIC SCR TEST *(Continued)*

1. Remove main supply power to the machine.
2. Remove the roof and case sides.
3. Lower the front control panel.
4. Remove Plug J4 from the firing board. See Figure F.7.

FIGURE F.7. FIRING BOARD LED & PLUG LOCATIONS

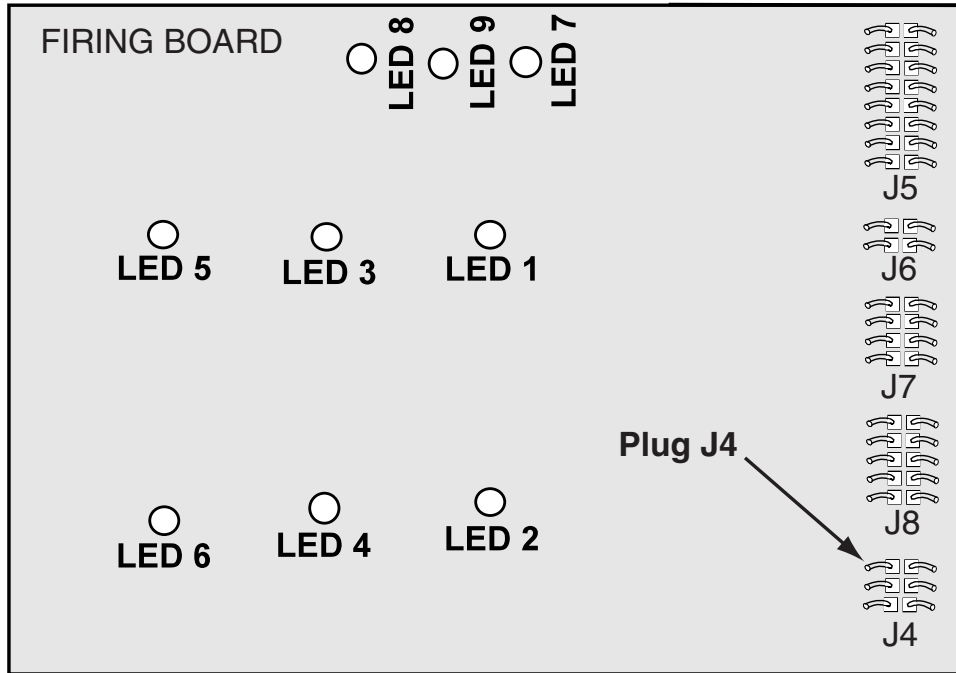

Return to Section TOC

Return to Section TOC

Return to Section TOC

Return to Section TOC

Return to Master TOC

Return to Master TOC

Return to Master TOC

Return to Master TOC

STATIC SCR TEST (Continued)

FIGURE F.8. Shunt and Lead Connections

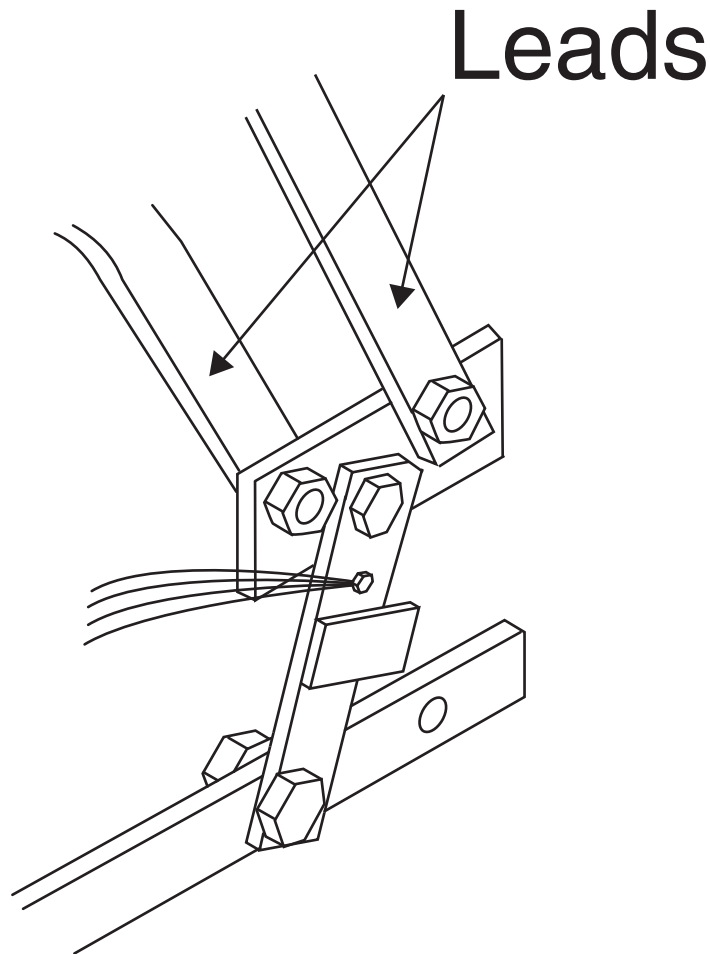

4. Using the 9/16" wrench, remove the two positive output leads connecting the output bridge to the shunt. See Figure F.8. This will partially electrically isolate the SCR Bridge for testing purposes. See Wiring Diagram.
 5. Remove the red insulating paint from heat sink test points. **See Figure F.9.**
- NOTE: DO NOT DISASSEMBLE THE HEAT SINKS.
6. Using an analog ohmmeter, test the resistance from anode to cathode of SCR 1. Reverse the meter leads and check from cathode to anode of SCR 1 (R x 1000 scale). **See Figure F.9.**
 - a. If a low resistance is indicated in either direction, one of the SCRs may be faulty. Further isolation will be necessary to determine which SCR is faulty. This isolation can be accomplished by disconnecting the transformer secondary lead from the SCR under test. See the Wiring Diagram.

STATIC SCR TEST (Continued)

FIGURE F.9. SCR HEAT SINK TEST POINTS

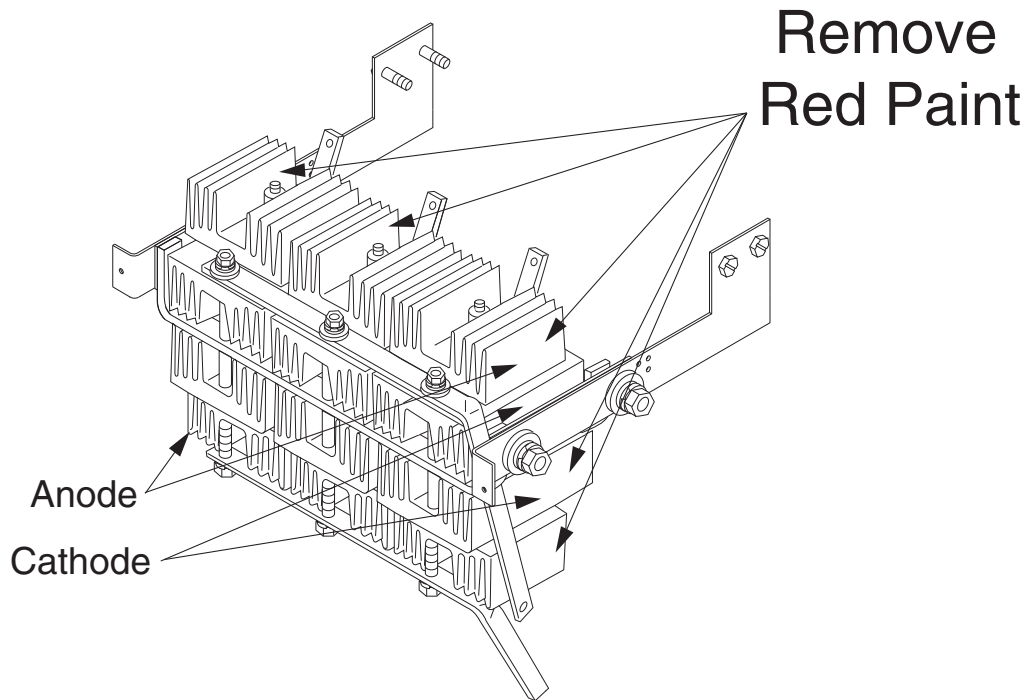

7. Repeat previous step(s) testing SCR 2, SCR 3, SCR 4, SCR 5, and SCR 6.

To further check the SCRs' functions use an SCR tester and proceed to **Active SCR Test**.

8. When test is completed, reconnect the positive bridge leads to the shunt.

9. Reconnect any secondary leads removed from the SCRs.

10. Reconnect Plug J4 into the firing board.

11. Replace the case top, sides and control panel.

ACTIVE SCR TEST

**WARNING**

Service and repair should be performed only by Lincoln Electric factory trained personnel. Unauthorized repairs performed on this equipment could result in danger to the technician or the machine operator and will invalidate your factory warranty. For your safety and to avoid electrical shock, please observe all safety notes and precautions detailed throughout this manual.

If for any reason you do not understand the test procedures or are unable to perform the tests/repairs safely, contact the Lincoln Electric Service Department for technical troubleshooting assistance before you proceed. Call 1-888-935-3877.

TEST DESCRIPTION

The active SCR Test will determine if the device is able to be gated "ON" and conduct current from anode to cathode.

MATERIALS NEEDED

An SCR Tester (as outlined in this procedure)
Analog Volt/Ohm Meter (Multimeter)
MULTI-SOURCE wiring diagrams (See Electrical Diagram Section of Manual).
3/8" Nut Driver
9/16" Wrench

This procedure takes approximately 45 minutes to perform.

TROUBLESHOOTING & REPAIR

ACTIVE SCR TEST (Continued)

1. Remove main supply power to the Multi-Source.
2. Remove the roof and case sides.
3. Lower the front control panel and remove Plug J4 from the Firing Board. See Figure F.10.

FIGURE F.10. FIRING BOARD LED & PLUG LOCATIONS

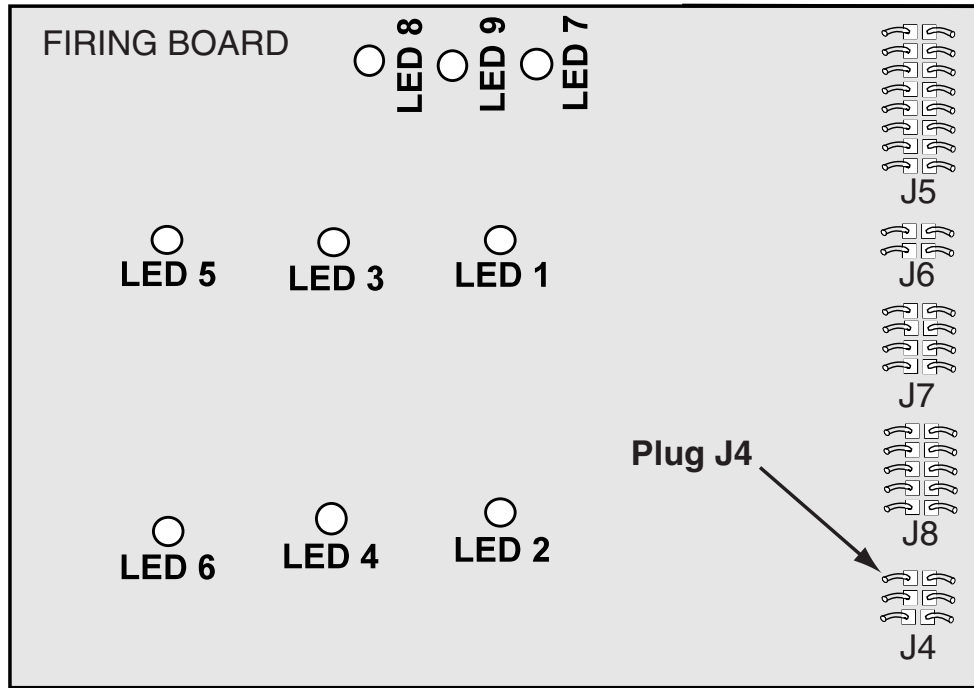

Return to Section TOC

Return to Section TOC

Return to Section TOC

Return to Section TOC

Return to Master TOC

Return to Master TOC

Return to Master TOC

Return to Master TOC

ACTIVE SCR TEST *(Continued)*

- Using a 9/16" wrench, remove the two positive output leads connecting the output bridge to the shunt. See Figure F.11. This will partially electrically isolate the SCR bridge for testing purposes. See the Wiring Diagram.

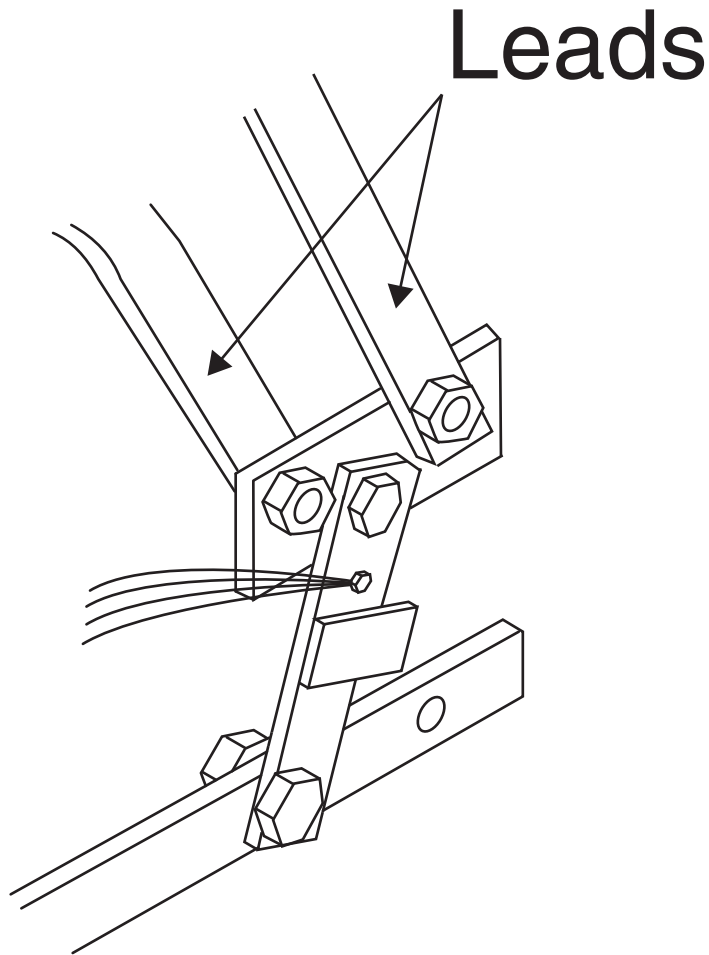
FIGURE F.11. Shunt and Lead Connections

ACTIVE SCR TEST (Continued)

FIGURE F.12. SCR Heat Sink Test Points

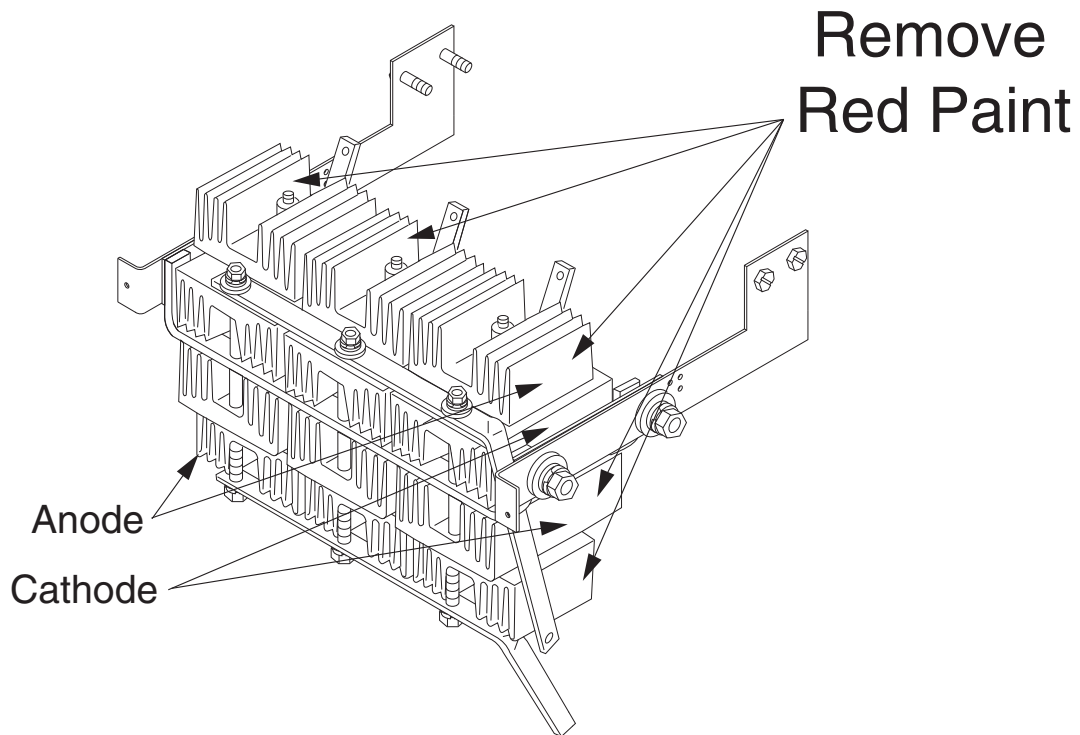

5. Remove the red insulating paint from heat sink test points. See Figure F.12.
6. Perform test procedure as follows. Refer to **Figure F.13**. Repeat test for all six SCRs.

NOTE: Do not disassemble the heat sinks.

ACTIVE SCR TEST (Continued)

FIGURE F.13. SCR Test Setup

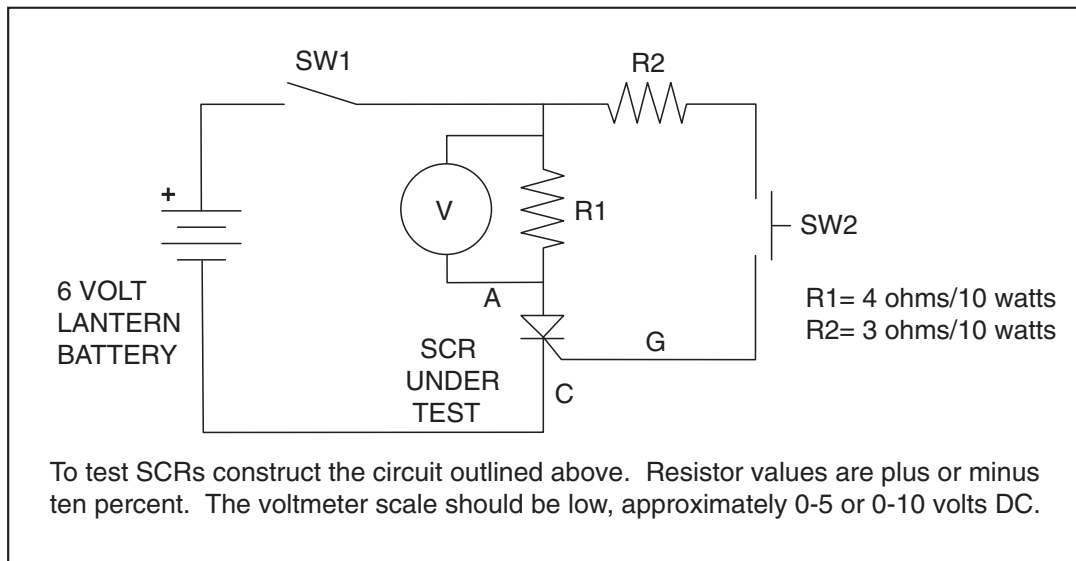

7. To test SCRs, construct the circuit outlined in Figure F.13. Use one 6V lantern battery. Resistor values are in ohms +/- 10%, The voltmeter scale should be low, approximately 0-5 or 0-10 volts.

BATTERY TEST

Check the battery by shorting leads (A) and (C) and then close switch SW1. Replace battery if voltage is less than 4.5 volts.

- A. Connect SCR into the test circuit as shown (A) lead to anode (C) lead to cathode and (G) lead to the gate.
- B. Close switch SW1 (switch SW2 should open), voltmeter should read zero. If the voltmeter reads higher than zero than the SCR is shorted.

NOTE: Do not disassemble the heat sinks.

8. With switch SW1 closed, close switch SW2 for two seconds and release. The

voltmeter should read 3 to 6 volts before and after switch SW2 is released. If the voltmeter does not read, or reads only while SW2 is depressed, the SCR or battery is defective (repeat battery Test Procedure).

9. Open switch SW1, disconnect the gate lead (G) and reverse the (A) and (C) leads on the SCR. Close switch SW2. The voltmeter should read zero. If the voltage is higher than zero, the SCR is shorted.
10. Replace any SCR assembly that does not pass test.
11. When test is completed, reconnect the positive bridge leads to the shunt.
12. Reconnect Plug J4 into the Firing Board.
13. Replace the case top, sides and control panel.

Return to Section TOC
Return to Master TOC

Return to Section TOC
Return to Master TOC

Return to Section TOC
Return to Master TOC

Return to Section TOC
Return to Master TOC



CONTROL BOARD TEST



WARNING

Service and repair should be performed only by Lincoln Electric factory trained personnel. Unauthorized repairs performed on this equipment could result in danger to the technician or the machine operator and will invalidate your factory warranty. For your safety and to avoid electrical shock, please observe all safety notes and precautions detailed throughout this manual.

If for any reason you do not understand the test procedures or are unable to perform the tests/repairs safely, contact the Lincoln Electric Service Department for technical troubleshooting assistance before you proceed. Call 1-888-935-3877.

TEST DESCRIPTION

This test will determine if the control board is receiving the correct voltages and feedback signals.

MATERIALS NEEDED

Volt/Ohm Meter (Multimeter)

MULTI-SOURCE wiring diagrams (See Electrical Diagram Section of Manual).

This procedure takes approximately 45 minutes to perform.

CONTROL BOARD TEST (Continued)

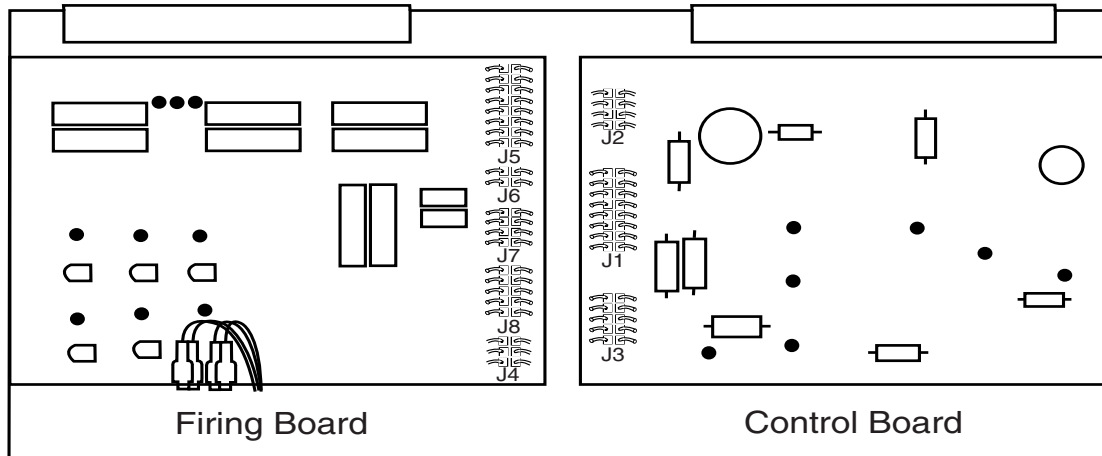
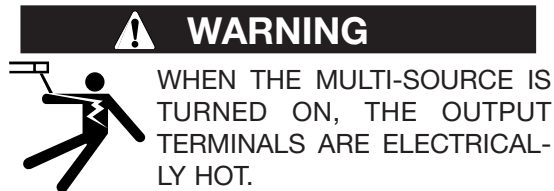

FIGURE F.14. CONTROL BOARD LOCATION

TEST PROCEDURE FOR NORMAL CONTROL BOARD OPERATION

1. Remove main supply power to the Multi-Source.
2. Remove screws, loosen and lower the front panel to access and inspect the control board located in the right side of the control box. See Figure F.14.
3. Apply the correct three-phase input power to the Multi-Source. Turn on the machine.



4. The white power light, located on the front control panel, indicates the control board is receiving the DC voltage that is supplied from the rectified secondary voltage of the control transformer. This voltage can range from 38VDC with 345VAC applied to the machines input, to 58VDC with 600VAC applied to the Multi-Source. This voltage can be measured at Plug J2-pin4 (+) lead #274, to plug J2-pin2 (-) lead #273. **See Figure F.15.** Normal voltage on the white light is 3.5VDC. If 5.0VDC is present the light may be open. This can be measured at plug J1-pin 7(+) lead #230 to plug J1-pin 8(-) lead #341.
5. LED 1 is an indication of the machine's output voltage. At normal output voltages LED1 should be brightly lit. Normal open circuit voltage (OCV) at the welding output terminals is approximately 80VDC. This voltage can be checked at Plug J1-pin 1(+)

lead #201 to Plug J1-pin 9(-) lead #222A. If the voltage is correct but LED1 is not lit, the control may be faulty. **See Figure F.15.**

6. LED 2 indicates the level of the control signal that is passed to the firing board. The brightness of LED 2 is inversely proportional to the output of the machine. As the control signal decreases (LED 2 gets dimmer) the machine's output increases. The control signal can be measured at Plug J1-pin 4(+) lead #231 to Plug J1-pin1(-) lead #201. Normal range is about 12VDC at open circuit to about 3VDC when high or maximum output is required. **See Figure F.15.**
7. LED 3 indicates that the machine's output is greater than 10 amps and the control board is developing a signal for the cooling fan to operate. This signal activates a fan motor driver circuit that is incorporated within the control board. See step 10 (LED 6).
8. LED 4 is an indication that either a thermostat, output current or output over-current is calling for the fan motor to operate. **See Figure F.15.**
9. LED 5 lights when the current feedback signal from the output shunt is too high. If LED 5 is lit for 5-8 seconds, the enable signal from the control board to the firing board is sent high (over 12VDC) (LED2). If the output current overload is of a short time duration LED 5 may only be lit briefly. In either case the machine's output will be zero and the output will remain off for about 75 seconds. **See Figure F.15.**

CONTROL BOARD TEST (Continued)

10. LED 6 indicates that the fan motor driver circuit has been activated and the fan motor should be running. LED 6 and the fan motor will be on for about 5 minutes after LED 4 goes off. See Figure F.15.
11. LED 7 will light if a positive voltage is present on the negative output terminal (AC instead of DC). This is an indication of a shorted SCR in the output bridge rectifier. See **SCR Rectifier Bridge Test**. The input contactor will open and will remain deenergized until the power switch is turned off for a minimum of 1 second. See Figure F.15.
12. The green light, located on the front control panel, is lit when the machine's output voltage is present and at a safe level. The voltage range is from 40VDC to 113VDC peak. This voltage can be measured at the output terminals and verified at Plug J1-pin 6(+) lead #215 to Plug J2-pin 1(-) lead #222D. See Figure F.15. If the output voltage is within range but the green light is not lit either the green light is faulty or the control board is faulty. Normal operating voltage for the green light is about 3.5VDC. A voltage of about 5.0VDC would indicate the light is open and the control board circuit is operating correctly.
13. The yellow (amber) light, located on the front panel, will light if the "open thermostat" (secondary and SCR heat sink) signal is sent to the fan control and output disable circuits. The voltage on the two thermostat circuit is from 24VDC to 38VDC. This voltage is dependent upon the input voltage applied to the Multi-Source. This voltage can be verified at Plug J1-pin 3(+) lead #263 to Plug J1-pin 11(-) lead #264. This voltage will be present if only one of the thermostats are open or an associated lead is disconnected. See the Wiring Diagram. Normal operating voltage for the amber light is about 2.2VDC. A voltage reading of about 5.0VDC would indicate the amber light is open and the control board is supplying the correct signal. This can be verified at Plug at Plug J1-pin 13(+) lead #234 to plug J1-pin 12(-) lead #235. This light voltage will normally be present **ONLY** when the thermostat circuit is open. See the Wiring Diagram. See Figure F.15.

FIGURE F.15. Control Board with LED, Plug and Lead Locations

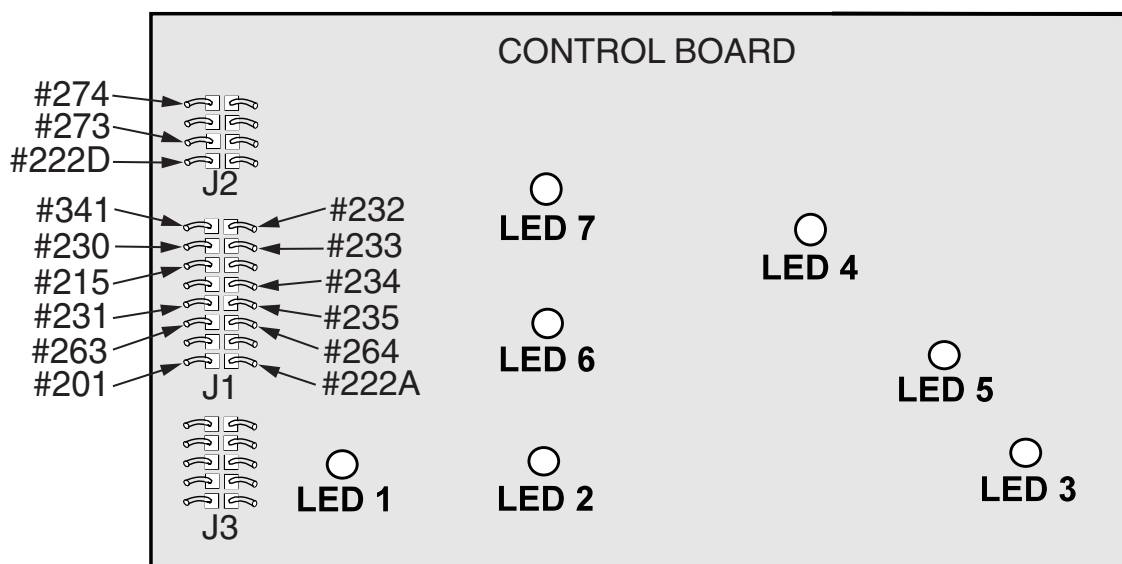

Return to Section TOC
Return to Master TOC

Return to Section TOC
Return to Master TOC

Return to Section TOC
Return to Master TOC

Return to Section TOC
Return to Master TOC



FIRING BOARD TEST

**WARNING**

Service and repair should be performed only by Lincoln Electric factory trained personnel. Unauthorized repairs performed on this equipment could result in danger to the technician or the machine operator and will invalidate your factory warranty. For your safety and to avoid electrical shock, please observe all safety notes and precautions detailed throughout this manual.

If for any reason you do not understand the test procedures or are unable to perform the tests/repairs safely, contact the Lincoln Electric Service Department for technical troubleshooting assistance before you proceed. Call 1-888-935-3877.

TEST DESCRIPTION

The Test determines whether or not the Firing Board is receiving the correct voltages and gate signals. The LEDs (Light Emitting Diodes) will help you determine if the Firing Board is Generating gate signals to the main SCRs.

MATERIALS NEEDED

Volt/Ohm Meter (Multimeter)

MULTI-SOURCE Wiring Diagram and Firing Board Schematic Diagram (See Electrical Diagram Section of Manual).

This procedure takes approximately 30 minutes to perform.

FIRING BOARD TEST (Continued)

FIGURE F.16. FIRING BOARD LOCATION

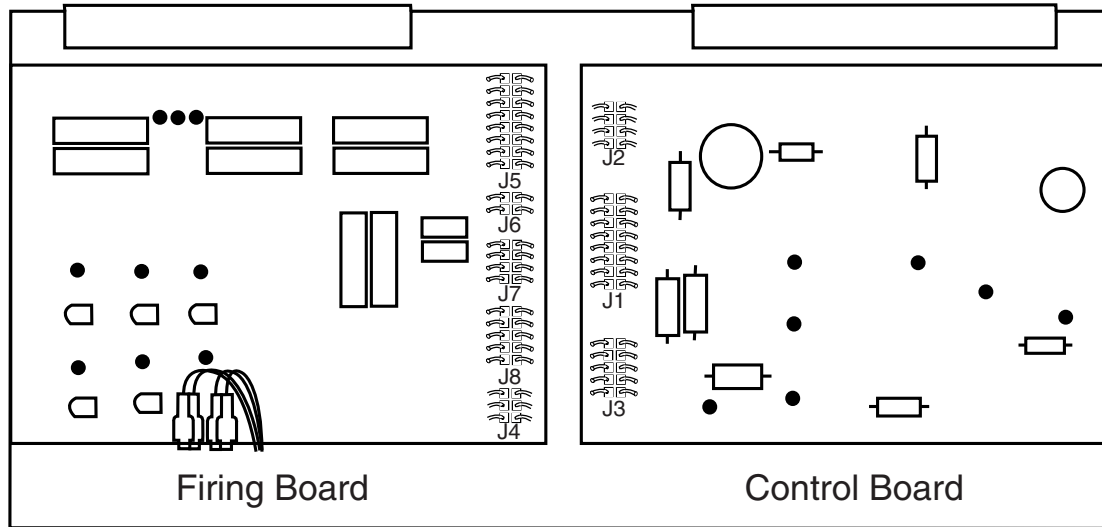

TEST PROCEDURE FOR NORMAL FIRING BOARD OPERATION

1. Disconnect main AC input power to the machine.
2. Remove screws, loosen and lower the front panel to access the firing board on the left side of control box while facing the machine. See Figure F.16.
3. Visually inspect the Firing Board for loose or faulty connections and obvious physical damage.

**WARNING****Electric Shock can kill.**

- With the input power on, there are high voltages inside the machine. Use caution when reaching into the machine or touching any internal part of the machine while the power is on. High voltage is present.

4. Reconnect the input power and turn the MULTI-SOURCE on.
5. Locate LEDs 7, 8, and 9 on the Firing Board. **See Figure F.17.** Each LED should be ON and equally bright. **Use Table F.2** to check LED operation.
6. Make certain that plug J7 (jumper plug) is in place. **See Figure F.17.** and the wiring diagram.

NOTE: To verify that the control board is sending the correct output enable signal to the firing board, check from plug J8, pin 7(+) (lead #340) to plug J5, pin 12 (-) (lead #215). **See Figure F.17.** See the wiring diagram. Normal voltage is approximately less than 1.0 VDC. If not correct the control board may be faulty.

7. Locate LEDs 1 thru 6. Each LED should glow with equal brightness.

NOTE: LEDs 1 through 6 indicate that the gate firing signals are being generated to send to each of the output SCRs.

8. If LED 2, located on the control board, is bright along with LEDs 7,8 and 9 on the Firing Board and LEDs 1 through 6 are unequal in brightness, check to make sure lead #231 is not loose or broken. See the wiring diagram. Normal voltage range at plug J5, pin 13 (+) (lead #231) to plug J5, pin 12 (-) (lead #215) is 3 to 13 VDC. At an open circuit condition the normal voltage is approximately 10 VDC. **See Figure F.17.**
9. If one or two of the LEDs 1 through 6 are dimmer or brighter than the others, this could indicate an open or shorted gate on an output SCR. Perform the **Static and Active SCR Tests.**

FIRING BOARD TEST (Continued)

TABLE F.2. - LED 7, 8 and 9 Check List

IF	THEN
LED 7 is ON	AC power is being supplied to the Firing Board from leads #283 and #284 connected, through the resistor bank, to the phase angle winding in the Main Transformer. See Figure F.17 . Normal voltage at leads #283 to #284 is 25 VAC.
LED 7 is OFF or is DIMMER than other LEDs	The proper AC voltage may not be reaching the Firing Board. Check for loose or faulty connections. Perform Main Transformer Test . Also check resistors R3 and R4 located in the resistor bank. Normal resistance is 50 ohms.
LED 8 is ON	AC power is being supplied to the Firing Board from leads #285 and #286 connected, through the resistor bank, to the phase angle winding in the Main Transformer. See Figure F.17 . Normal voltage at leads #285 to #286 is 25 VAC.
LED 8 is OFF or is DIMMER than other LEDs	The proper AC voltage may not be reaching the Firing Board. Check for loose or faulty connections. Perform Main Transformer Test . Also check resistors R5 and R6 located in the resistor bank. Normal resistance is 50 ohms.
LED 9 is ON	AC power is being supplied to the Firing Board from leads #287 and #288 connected, through the resistor bank, to the phase angle winding in the Main Transformer. See Figure F.17 . Normal voltage at leads #287 to #288 is 25 VAC.
LED 9 is OFF or is DIMMER than other LEDs	The proper AC voltage may not be reaching the Firing Board. Check for loose or faulty connections. Perform Main Transformer Test . Also check resistors R7 and R8 located in the resistor bank. Normal resistance is 50 ohms.

FIRING BOARD TEST (Continued)

FIGURE F.17. FIRING BOARD PLUG & PIN LOCATIONS

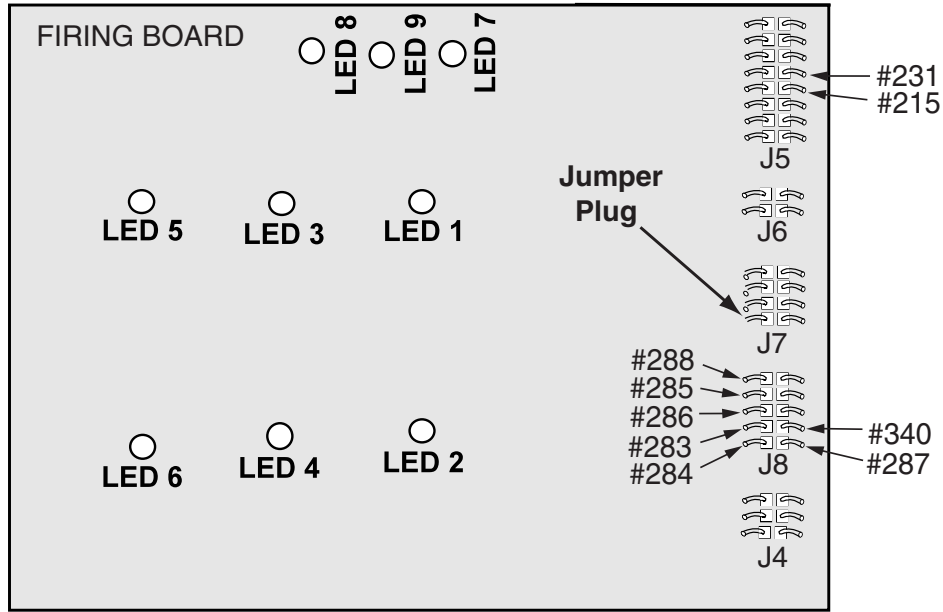

Return to Section TOC

Return to Section TOC

Return to Section TOC

Return to Section TOC

Return to Master TOC

Return to Master TOC

Return to Master TOC

Return to Master TOC

MULTI-SOURCE METER ACCURACY CHECK

**WARNING**

Service and repair should be performed only by Lincoln Electric factory trained personnel. Unauthorized repairs performed on this equipment could result in danger to the technician or the machine operator and will invalidate your factory warranty. For your safety and to avoid electrical shock, please observe all safety notes and precautions detailed throughout this manual.

If for any reason you do not understand the test procedures or are unable to perform the tests/repairs safely, contact the Lincoln Electric Service Department for technical troubleshooting assistance before you proceed. Call 1-888-935-3877.

TEST DESCRIPTION

This procedure will aid the technician in checking and calibrating the meter display.

MATERIALS NEEDED

DC ammeter and meter grade shunt, +/- 1% accuracy
Resistive load bank and/or Multi-Weld machines

This procedure takes approximately 30 minutes to perform.

MULTI-SOURCE METER ACCURACY CHECK (Continued)

METER ACCURACY CHECK

1. With power off, connect a resistive load and the meter grade shunt to the output terminals. Use either a resistive grid, multisource welders or a combination of both.
2. Turn machine on.
3. Adjust the resistive load to approximately 533 amps DC as read by the DC ammeter via the meter grade shunt.
4. The Multi-Source digital display should read approximately "100".
5. If the result is satisfactory the the test is over and the machine may be reassembled. If the required results are not obtained proceed to the next section.

PROCEDURE TO RECALIBRATE IF METER IS OUT OF RANGE

If the measured current is within the acceptable current range (approximately 533 amps DC) and the Multi-Source digital display does not read approximately "100" then the meter must be recalibrated. The Multi-Source digital display is controlled by a current sensing circuit on the Control board. The display should read "100" when the machine output is a little over 40 kW. To adjust the digital meter, trimmer resistor R49 on the Control board may be adjusted. See Figure F.18. for location of R49 trimmer.

If the meter can not be calibrated using this procedure then the Control board or the output shunt may be faulty. See the Wiring Diagram.

Note: The output shunt is rated at 50 mv @ 800 A.

FIGURE F.18. R49 TRIMMER

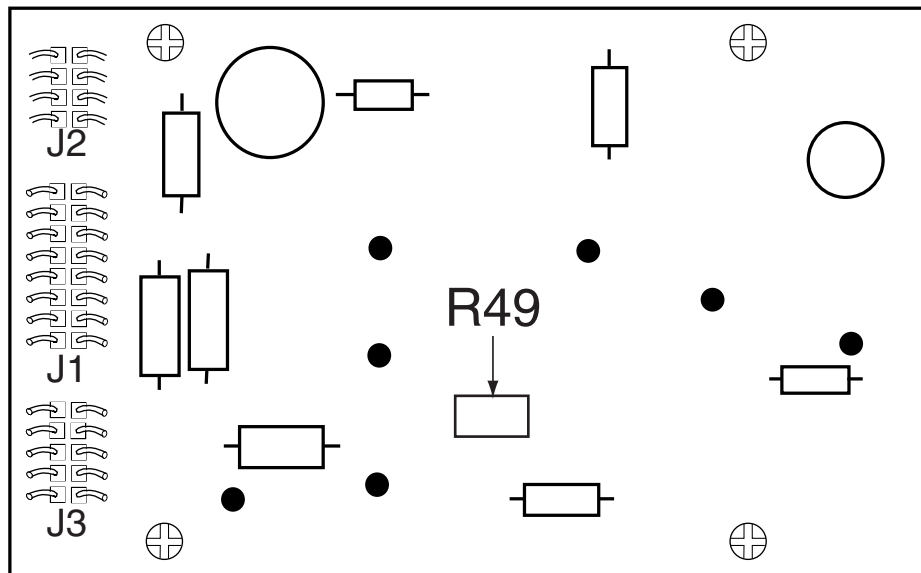

Control Board

TROUBLESHOOTING & REPAIR

NORMAL OPEN CIRCUIT VOLTAGE WAVEFORM - NO LOAD

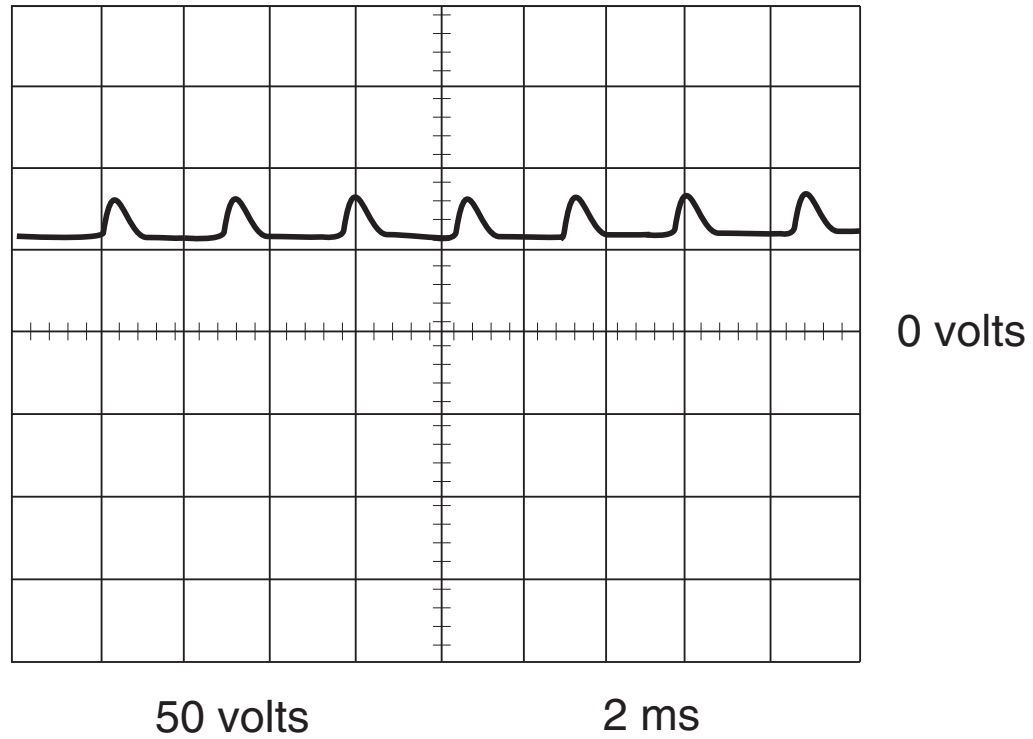

This is the typical DC open circuit voltage waveform generated from a properly operating machine. Note that each vertical division represents 50 volts and that each horizontal division represents 2 milliseconds in time.

Note: Scope probes connected at machine output terminals: (+) probe to positive terminal, (-) probe to negative terminal.

Scope Settings

Volts/Div.....	50 V/Div.
Horizontal Sweep.....	2 ms/Div.
Coupling.....	DC
Trigger.....	Internal

Return to Section TOC
Return to Master TOC

Return to Section TOC
Return to Master TOC

Return to Section TOC
Return to Master TOC

Return to Section TOC
Return to Master TOC

ABNORMAL OPEN CIRCUIT VOLTAGE WAVEFORM ONE OUTPUT SCR NOT FUNCTIONING - NO LOAD

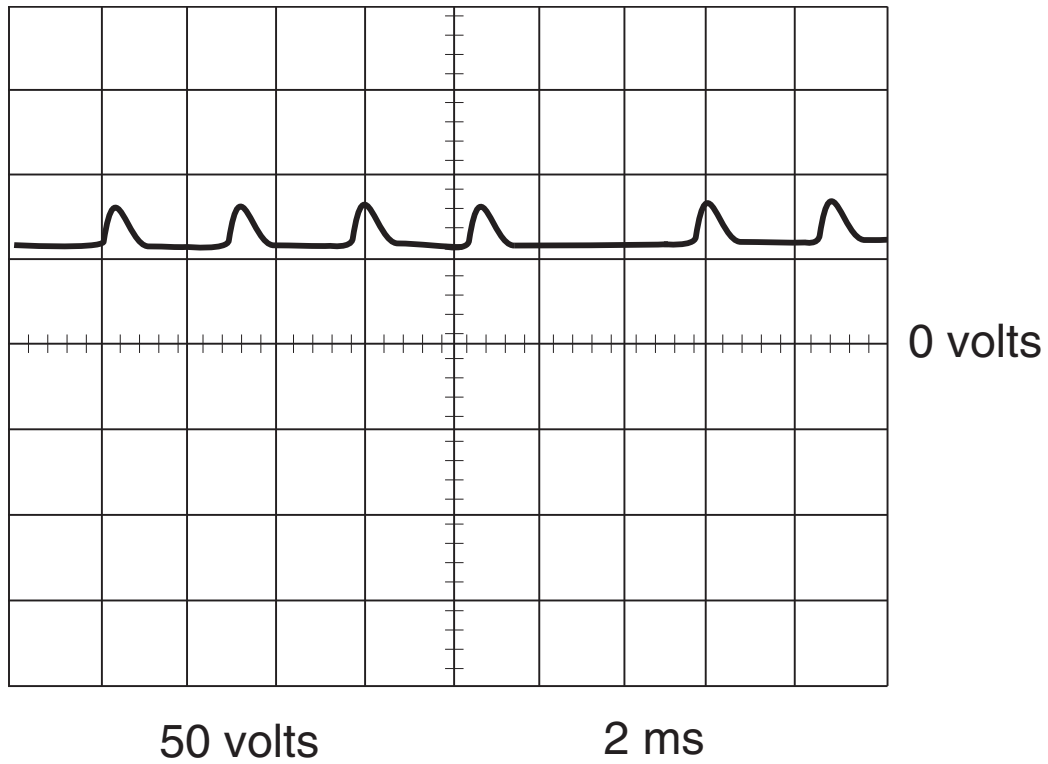

This is NOT the typical DC output voltage waveform. One output SCR is not functioning. Note the “gap” in the waveform. One SCR gate is disconnected to simulate an open or non-functioning output SCR. Each vertical division represents 50 volts and each horizontal division represents 2 milliseconds in time.

Note: Scope probes connected at machine output terminals: (+) probe to positive terminal, (-) probe to negative terminal.

Scope Settings

Volts/Div.....	50 V/Div.
Horizontal Sweep.....	2 ms/Div.
Coupling.....	DC
Trigger.....	Internal

Return to Section TOC
Return to Section TOC
Return to Section TOC
Return to Section TOC
Return to Section TOC

Return to Master TOC
Return to Master TOC
Return to Master TOC
Return to Master TOC
Return to Master TOC

Return to Section TOC
Return to Master TOC

Return to Section TOC
Return to Master TOC

Return to Section TOC
Return to Master TOC

Return to Section TOC
Return to Master TOC



INPUT CONTACTOR CLEANING AND/OR REPLACEMENT



WARNING

Service and repair should be performed only by Lincoln Electric factory trained personnel. Unauthorized repairs performed on this equipment could result in danger to the technician or the machine operator and will invalidate your factory warranty. For your safety and to avoid electrical shock, please observe all safety notes and precautions detailed throughout this manual.

If for any reason you do not understand the test procedures or are unable to perform the tests/repairs safely, contact the Lincoln Electric Service Department for technical troubleshooting assistance before you proceed. Call 1-888-935-3877.

DESCRIPTION

The following procedure will aid the technician in removing the Input Contactor for maintenance, repair, or cleaning.

MATERIALS NEEDED

3/8" Nut Driver
7/16" Nut Driver
11/16" Nut Driver
1/2" Nut Driver

This procedure takes approximately 40 minutes to perform.

INPUT CONTACTOR CLEANING AND/OR REPLACEMENT (*Continued*)

FIGURE F.19. INPUT CONTACTOR (top view)

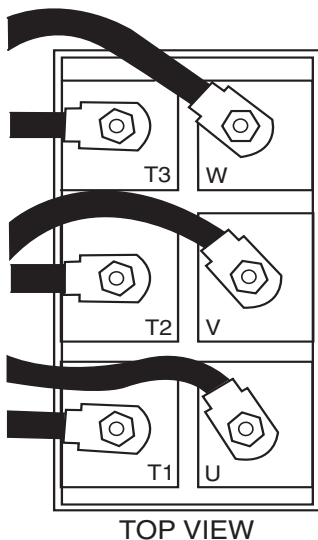

TOP VIEW

REMOVAL PROCEDURE

1. Disconnect input power to the machine.
2. Remove case sides and roof using a 3/8" nut driver.
3. Label leads T1, T2, T3, U, V, W and their respective terminals. See Figure F.19.
4. Using a 11/16" nut driver, remove the six leads connected to the input contactor.
5. Using a 7/16" nut driver, remove the four bolts mounting the input contactor to the frame of the machine. Note washer positions for replacement. See Figure F.20.
6. Disconnect leads 240 and 241 using quick connects located in loom.
7. Carefully lift input contactor out of machine.

8. For contactor cleaning or inspection see **Figure F.21**.

REPLACEMENT PROCEDURE

1. Mount input contactor to machine frame using the four bolts, washers, and nuts previously removed.
2. Reconnect leads #240 and #241.
3. Reconnect leads T1, T2, T3, U, V, W previously removed.
4. Replace case sides and roof previously removed.

FIGURE F.20. 7/16" MOUNTING BOLTS

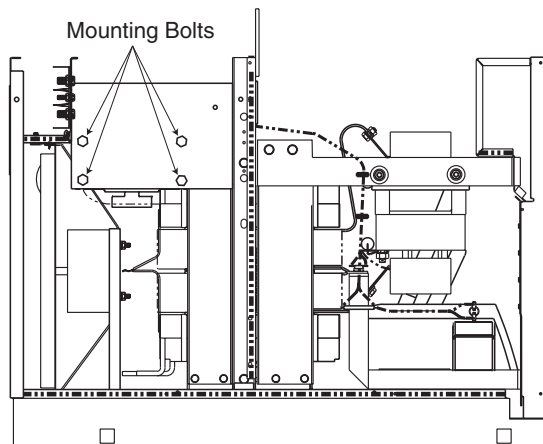

LEFT SIDE

INPUT CONTACTOR CLEANING AND/OR REPLACEMENT *(Continued)*

FIGURE F.21. INPUT CONTACTOR CLEANING/INSPECTION

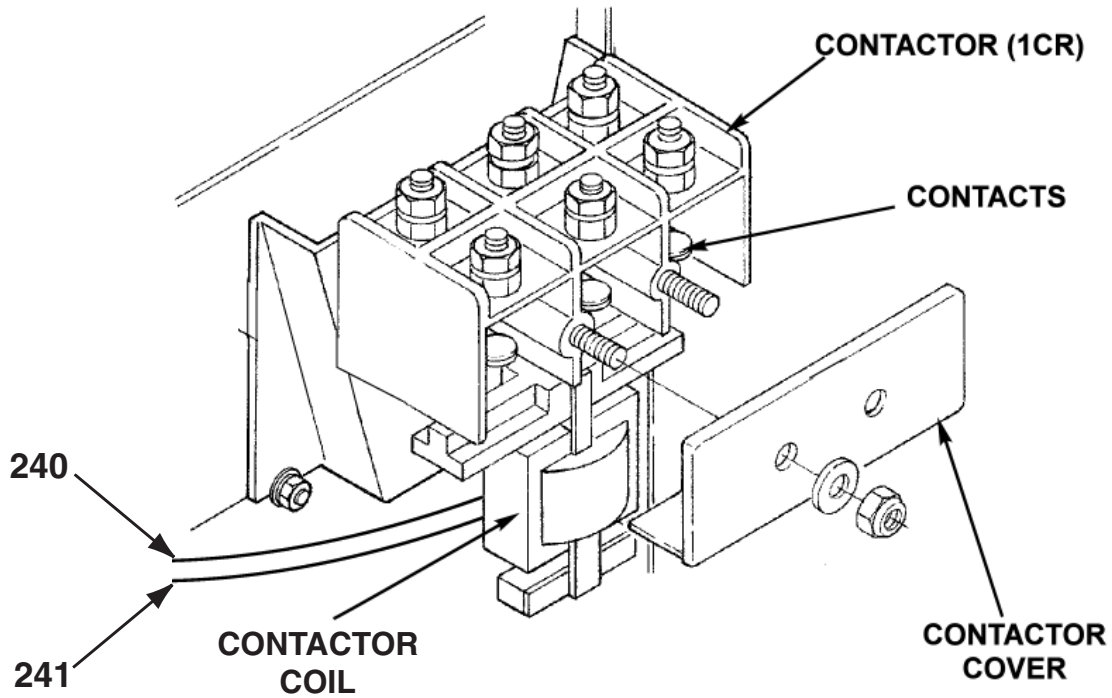

Return to Section TOC
Return to Master TOC
Return to Section TOC
Return to Master TOC
Return to Section TOC
Return to Master TOC
Return to Section TOC
Return to Master TOC
Return to Section TOC
Return to Master TOC

Return to Section TOC
Return to Master TOC

Return to Section TOC
Return to Master TOC

Return to Section TOC
Return to Master TOC

Return to Section TOC
Return to Master TOC



CONTROL BOARD REPLACEMENT PROCEDURE**WARNING**

Service and repair should be performed only by Lincoln Electric factory trained personnel. Unauthorized repairs performed on this equipment could result in danger to the technician or the machine operator and will invalidate your factory warranty. For your safety and to avoid electrical shock, please observe all safety notes and precautions detailed throughout this manual.

If for any reason you do not understand the test procedures or are unable to perform the tests/repairs safely, contact the Lincoln Electric Service Department for technical troubleshooting assistance before you proceed. Call 1-888-935-3877.

DESCRIPTION

The following procedure will aid the technician in removing the control board for replacement.

MATERIALS NEEDED

3/8" Nut Driver
Phillips Head Screwdriver
Pliers (optional)

This procedure takes approximately 30 minutes to perform.

CONTROL BOARD REPLACEMENT PROCEDURE *(Continued)*

FIGURE F.22. FRONT PANEL W/OUT COVER

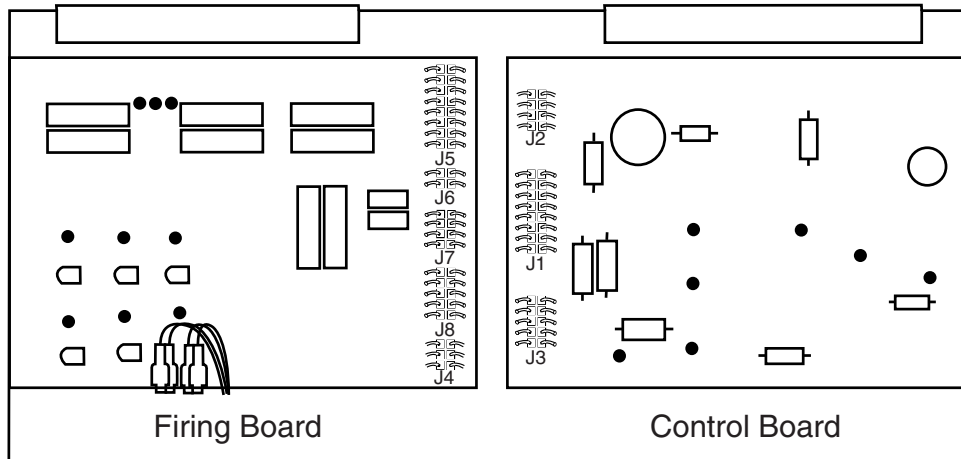

REMOVAL PROCEDURE

1. Disconnect input power to the machine.
2. Using a 3/8" nut driver, remove screws and lower the front control panel to access the control board on the right side of control box while facing the machine. See Figure F.22.
3. Disconnect plugs J2, J1, and J3 from the control board.
4. Remove the four phillips head screws and associated washers from the corners of the control board. See Figure F.23.

5. Carefully remove the control board.

REPLACEMENT PROCEDURE

1. Replace the control board.
2. Mount the control board to the machine in its proper position using the four phillips head screws and associated washers previously removed.
3. Reconnect plugs J3, J1, and J2 to the control board.
4. Replace the four screws previously removed from the front control panel.

FIGURE F.23. MOUNTING SCREW LOCATIONS

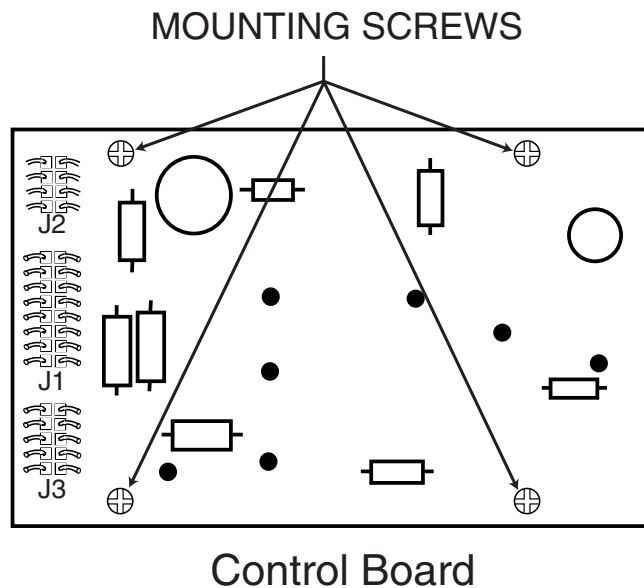

[Return to Section TOC](#) | [Return to Section TOC](#) | [Return to Section TOC](#) | [Return to Master TOC](#) | [Return to Master TOC](#) | [Return to Master TOC](#) | [Return to Master TOC](#)

FIRING BOARD REPLACEMENT PROCEDURE

**WARNING**

Service and repair should be performed only by Lincoln Electric factory trained personnel. Unauthorized repairs performed on this equipment could result in danger to the technician or the machine operator and will invalidate your factory warranty. For your safety and to avoid electrical shock, please observe all safety notes and precautions detailed throughout this manual.

If for any reason you do not understand the test procedures or are unable to perform the tests/repairs safely, contact the Lincoln Electric Service Department for technical troubleshooting assistance before you proceed. Call 1-888-935-3877.

DESCRIPTION

The following procedure will aid the technician in removing the firing board for replacement.

MATERIALS NEEDED

3/8" Nut Driver
Phillips Head Screwdriver
Pliers (optional)

This procedure takes approximately 30 minutes to perform.

TROUBLESHOOTING & REPAIR

FIRING BOARD REPLACEMENT PROCEDURE *(Procedure)*

FIGURE F.24. FRONT PANEL W/OUT COVER

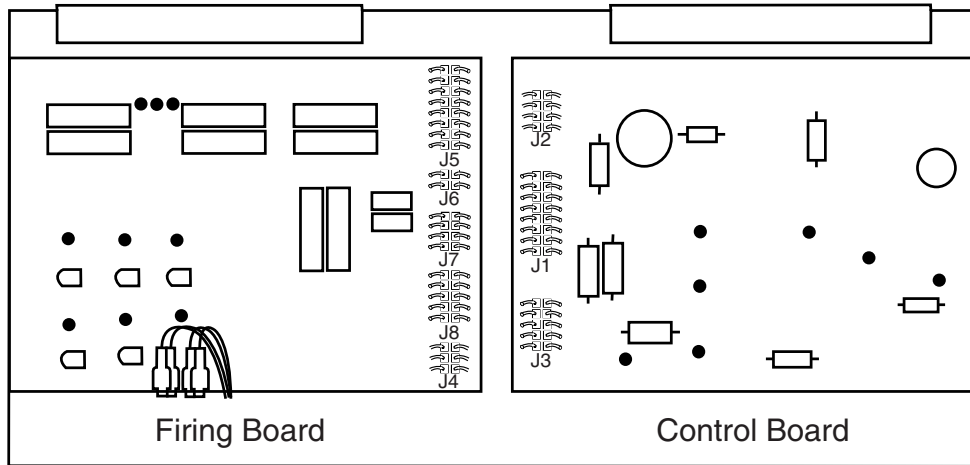

REMOVAL PROCEDURE

1. Disconnect input power to the machine.
2. Using a 3/8" nut driver, remove screws and lower the front control panel to access the firing board on the left side of control box while facing the machine. See Figure F.24.
3. Disconnect plugs J5, J8, and J4 from the firing board.
4. Remove the four phillips head screws and associated washers from the corners of the firing board. See Figure F.25.
5. Carefully remove the firing board.

REPLACEMENT PROCEDURE

1. Replace the firing board.
 2. Mount the firing board to the machine in its proper position using the four phillips head screws and associated washers previously removed.
 3. Reconnect plugs J4, J8, and J5 to the firing board.
- NOTE: Be sure plug J7 is installed in the new board.
4. Replace the four screws previously removed from the front access panel.

FIGURE F.25. MOUNTING SCREW LOCATIONS

MOUNTING SCREWS

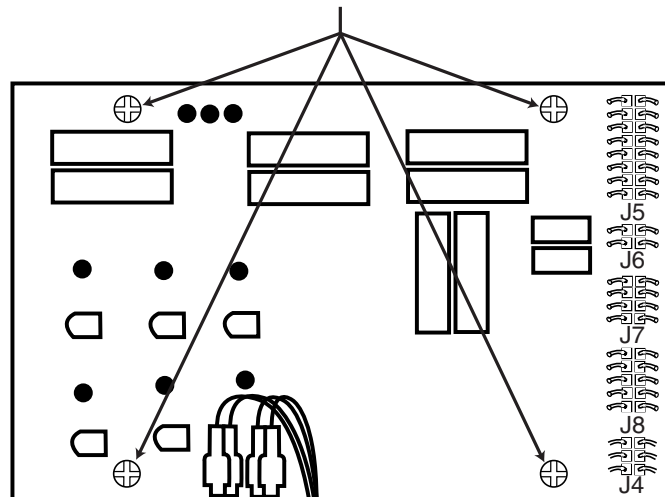

Firing Board

[Return to Section TOC](#) | [Return to Master TOC](#) | [Return to Section TOC](#) | [Return to Master TOC](#) | [Return to Section TOC](#) | [Return to Master TOC](#) | [Return to Section TOC](#) | [Return to Master TOC](#)

SCR BRIDGE / HEAT SINK ASSEMBLY REPLACEMENT PROCEDURE



WARNING

Service and repair should be performed only by Lincoln Electric factory trained personnel. Unauthorized repairs performed on this equipment could result in danger to the technician or the machine operator and will invalidate your factory warranty. For your safety and to avoid electrical shock, please observe all safety notes and precautions detailed throughout this manual.

If for any reason you do not understand the test procedures or are unable to perform the tests/repairs safely, contact the Lincoln Electric Service Department for technical troubleshooting assistance before you proceed. Call 1-888-935-3877.

DESCRIPTION

The following procedure will aid the technician in removing the SCR bridge and/or an individual heat sink assembly for repair or replacement.

MATERIALS NEEDED

3/8" Nut Driver
9/16" Nut Driver
1/2" Nut Driver
Solder
Solder Gun/Iron
T12837 (Dow Corning 340) Heatsink Compound

This procedure takes approximately 2 Hours to perform.

SCR BRIDGE / HEAT SINK ASSEMBLY REPLACEMENT PROCEDURE

FIGURE F.26. Bolt and Lead Locations

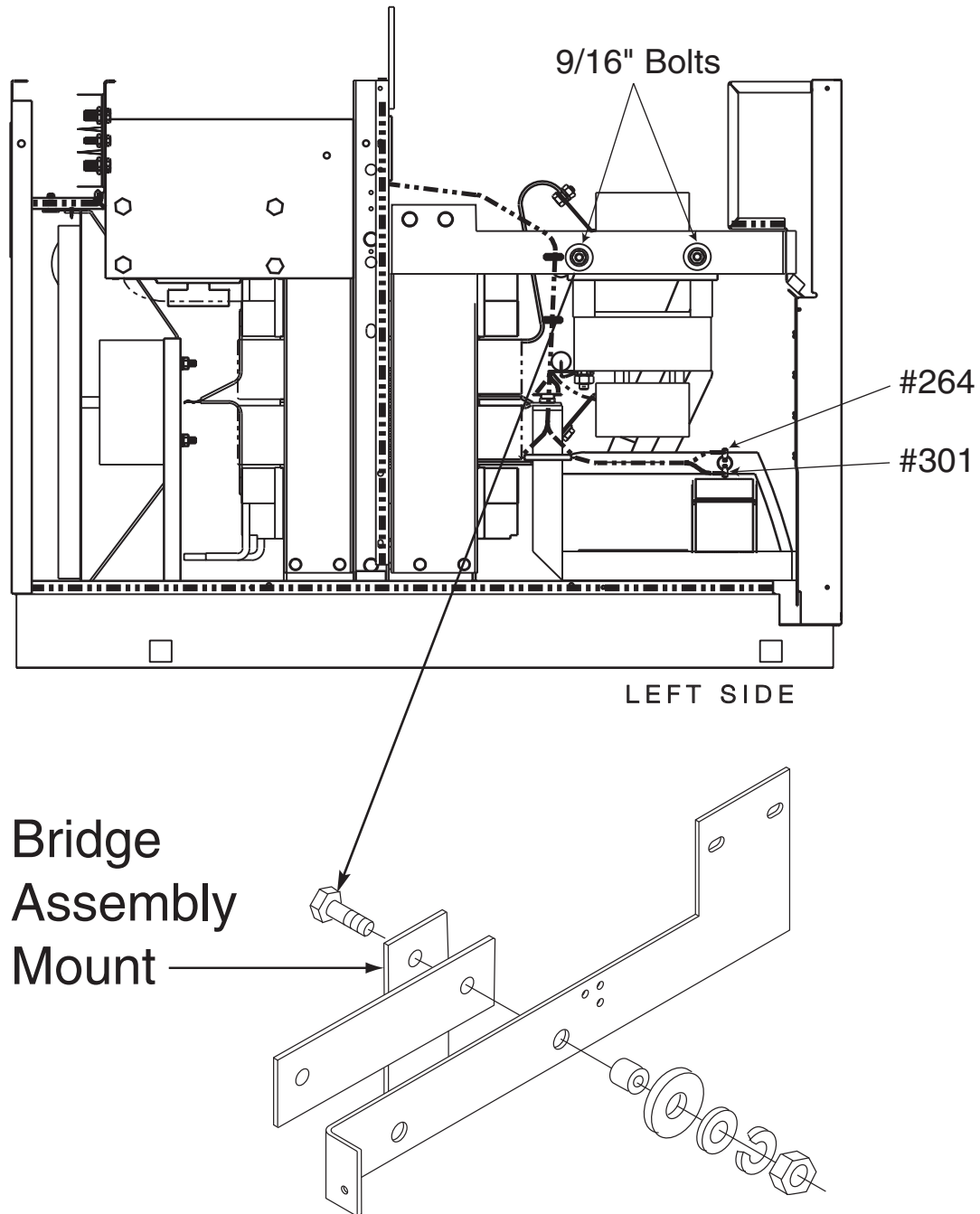
**REMOVAL PROCEDURE**

1. Disconnect input power to the machine.
2. Using a 3/8" nut driver, remove the case sides and roof.
3. Locate, label, and remove leads #301 and #264 from the thermostat. See Figure F.26.
4. Lower the control panel using a 3/8" nut driver.
5. Remove plug J4 from the firing board and feed the disconnected plug down through the hole in the bottom of the P.C. board control box.

SCR BRIDGE / HEAT SINK ASSEMBLY REPLACEMENT PROCEDURE

FIGURE F.27. Bolt, Lead, and Shunt Locations

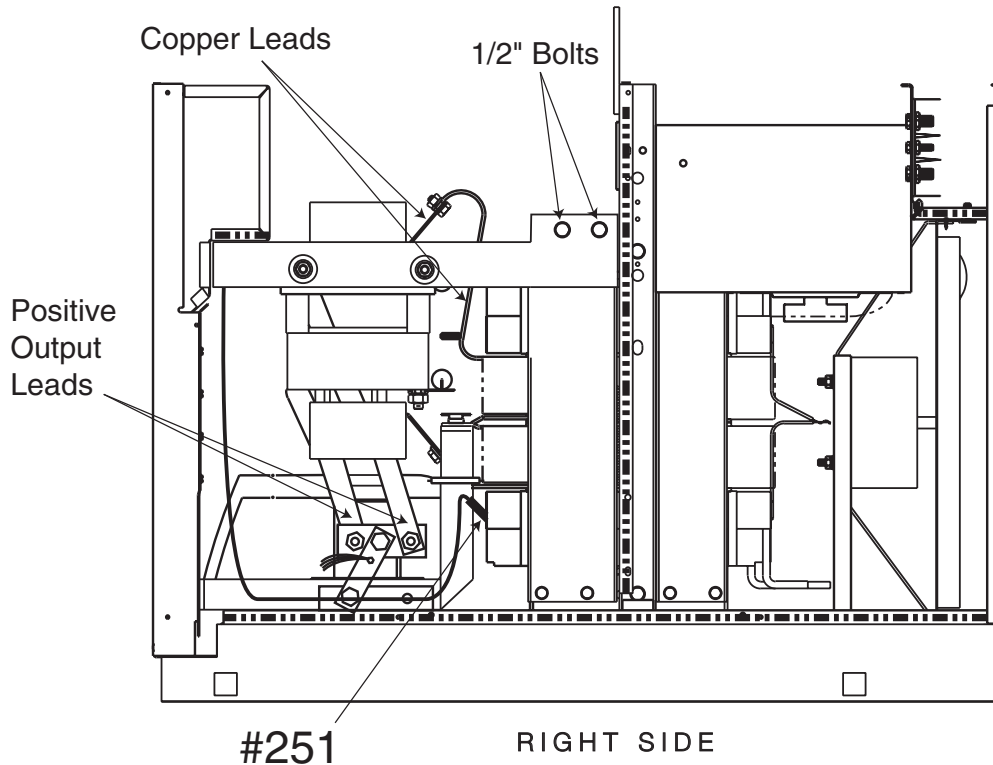

6. Using a 9/16" nut driver, remove the two positive output leads connecting the output bridge to the shunt. See Figure F.27.
7. Using a 1/2" nut driver disconnect the six copper transformer secondary leads connected to the SCR bridge from the main transformer. Three leads are located on the top and three on the bottom. See Figure F.27.
8. Using a 3/8" nut driver remove the right bolt mounting the SCR bridge to the front assembly. The bolt is located below the control board. **See Figure F.28.**
9. Cut any necessary cable ties.
10. Using a 1/2" nut driver, remove the two mounting bolts on the right side of the machine mounting the SCR bridge to the main transformer.
11. Using a 9/16" nut driver, remove two bolts covered in red insulating paint on the left side of the machine only. These two bolts are located above leads #301 and #264. **See Figure F.26.** Note position of insulation, nut, bushing, and washer placement upon removal. **See Figure F.26.**
12. Locate, label and remove lead #251 from main transformer. The solder connection must be broken to disconnect. See Figure F.27.

TROUBLESHOOTING & REPAIR

SCR BRIDGE / HEAT SINK ASSEMBLY REPLACEMENT PROCEDURE

FIGURE F.28. Mounting Bolt

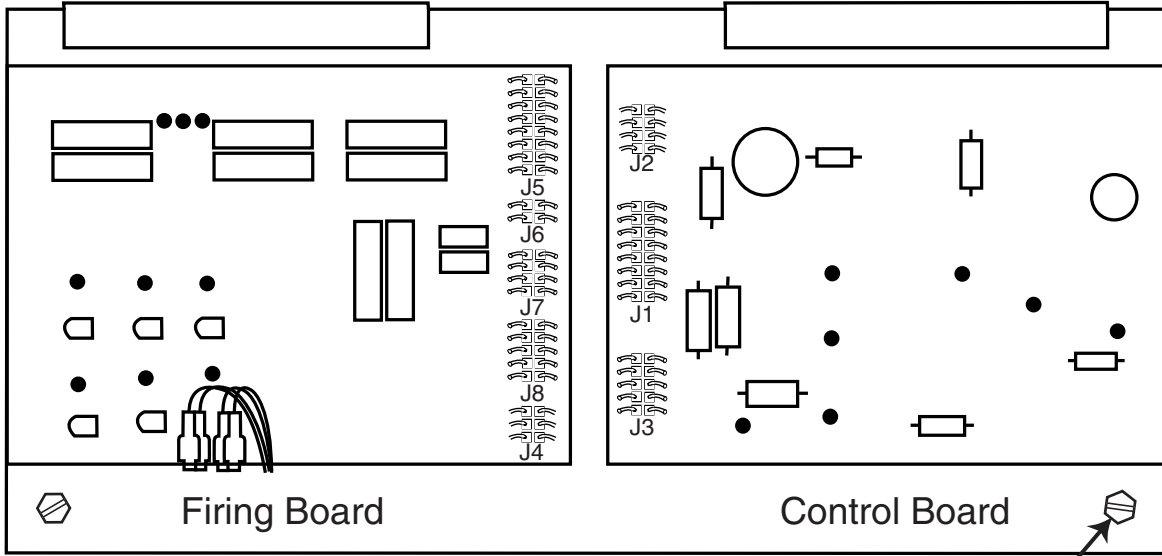

Mounting Bolt

13. Clear all leads and carefully maneuver SCR bridge out of the right side of the machine.

NOTE: Upon reassembly, apply a thin layer of Lincoln Electric T12837 (Dow Corning 340) heat sink compound to all bolted electrical connections on the aluminum heat sinks.

CAUTION

UPON REASSEMBLY, THE SCR BRIDGE ASSEMBLY MUST BE ELECTRICALLY ISOLATED FROM GROUND. MINIMUM ACCEPTABLE RESISTANCE TO GROUND IS 500K OHMS.

Return to Section TOC
Return to Section TOC
Return to Section TOC
Return to Section TOC
Return to Section TOC
Return to Section TOC

Return to Master TOC
Return to Master TOC
Return to Master TOC
Return to Master TOC
Return to Master TOC
Return to Master TOC

SCR BRIDGE / HEAT SINK ASSEMBLY REPLACEMENT PROCEDURE

FIGURE F.29. Individual Heatsink Removal

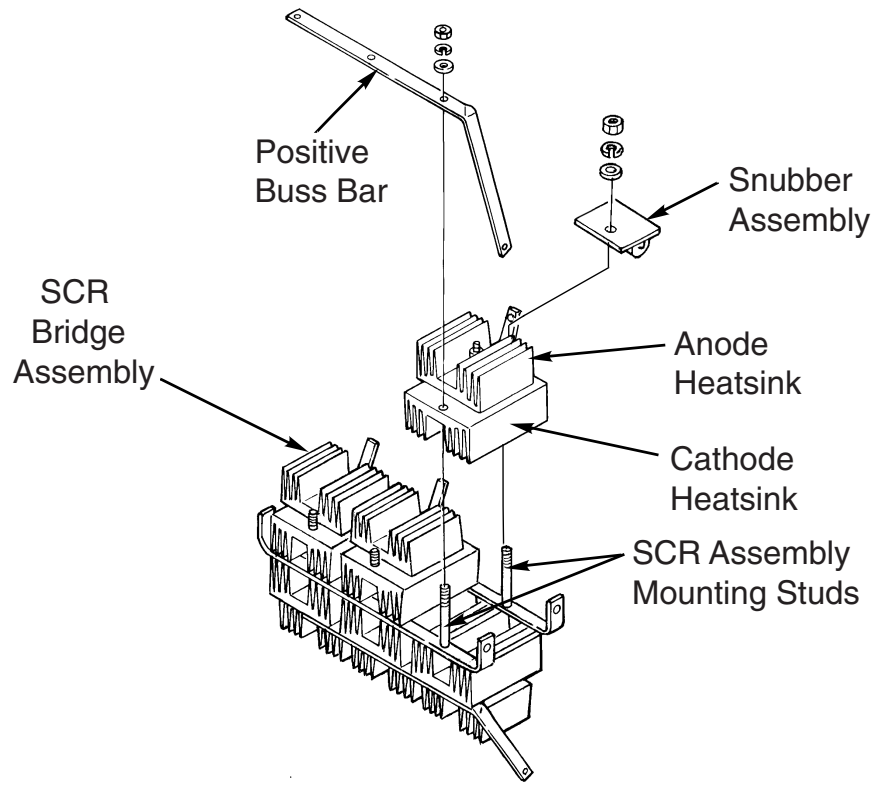

REMOVAL OF INDIVIDUAL SCR HEAT SINK ASSEMBLIES

1. Using a 9/16" nut driver, remove the nuts and respective washers securing the positive buss bar in position. Remove buss bar. See Figure F.29.
2. Using a 9/16" nut driver, remove the nut and respective washers securing the snubber board and cathode heatsink to the main assembly. See Figure F.29.
3. Carefully remove the SCR heatsink from the mounting studs. Replacement will be made with a new SCR assembly.
4. Replace snubber assembly if necessary.

CAUTION

DO NOT DISASSEMBLE THE SCR FROM THE HEAT SINK. REPLACE THE SCR ONLY AS AN ASSEMBLY.

INSTALLATION OF INDIVIDUAL SCR HEAT SINK ASSEMBLIES

NOTE: Upon reassembly, apply a thin layer of Lincoln T12837 (Dow Corning #340) heat sink compound to all bolted electrical connections on the aluminum heat sinks, including positive buss bar.

1. Carefully position new SCR assembly on to heatsink mounting studs.
2. Place positive buss bar back in original position.
3. Replace 9/16" nuts and washers previously removed.

SCR BRIDGE / HEAT SINK ASSEMBLY REPLACEMENT PROCEDURE

INSTALLATION OF SCR OUTPUT BRIDGE

NOTE: Upon reassembly, apply a thin layer of Lincoln T12837 (Dow Corning #340) heat sink compound to all bolted electrical connections on the aluminum heat sinks, including positive buss bar.

1. Carefully maneuver SCR bridge back into original position.
2. Using a solder iron, reconnect lead #251 to the main transformer and insulate.
3. Replace the two 9/16" mounting bolts previously removed. Be sure to position insulation, bushing, washer, and nut correctly. **See Figure F.26.**
4. Replace the two 1/2" mounting bolts on the right side of the machine previously removed. These bolts mount the SCR bridge to the main transformer. **See Figure F.27.**
5. Replace any previously removed cable ties.
6. Replace the 3/8" mounting screw previously removed from the front of the machine located behind the control panel.
7. Reconnect plug J4 to the firing board.
8. Replace the four screws previously removed from the front control panel.
9. Reconnect the six copper transformer secondary leads previously removed.
10. Reconnect the two positive output leads to the shunt.
11. Reconnect leads #264 and #301 previously removed from the thermostat.
12. Replace the case sides and roof.

RETEST AFTER REPAIR

Testing is required after the removal of any mechanical part that could affect the machine's electrical characteristics, or if any electrical components are repaired or replaced.

NO LOAD READINGS (FAN OFF)

Input Volts/Phase/Hertz	Maximum Idle Amps	Maximum Idle KW
380/3/50	15.0	2.0
400/3/50	20.0	2.25
415/3/50	25.0	2.5
460/3/60	6.5	2.0
500/3/50	17.0	2.0
575/3/60	6.5	2.0

MAXIMUM OPEN CIRCUIT VOLTAGE

Open Circuit Volts
79.5/80 VDC

PERFORM METER ACCURACY TEST

Return to Section TOC
Return to Master TOC

Return to Section TOC
Return to Master TOC

Return to Section TOC
Return to Master TOC

Return to Section TOC
Return to Master TOC



TABLE OF CONTENTS
-ELECTRICAL DIAGRAMS SECTION-

ELECTRICAL DIAGRAMS SECTION G
 WIRING DIAGRAM G-2
 CONTROL PC BOARD SCHEMATIC G-3
 CONTROL PC BOARD ASSEMBLY G-4
 FIRING PC BOARD SCHEMATIC G-5
 FIRING PC BOARD ASSEMBLY G-6
 SNUBBER PC BOARD ASSEMBLY G-7

Return to Master TOC

Return to Master TOC

Return to Master TOC

Return to Master TOC

MULTI-SOURCE



WIRING DIAGRAM -

MULTI-SOURCE WIRING DIAGRAM

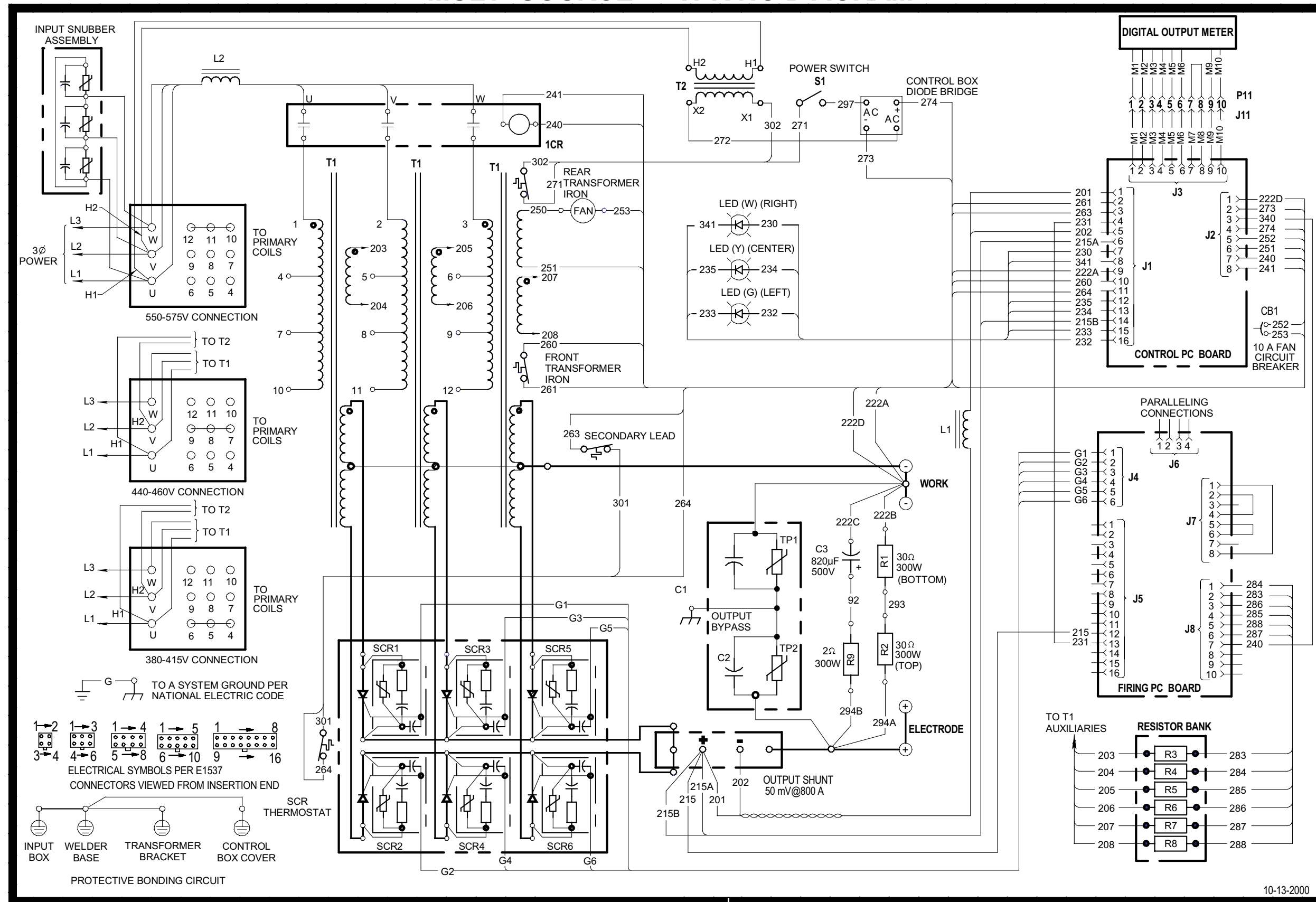

10-13-2000

L11414

NOTE: This diagram is for reference only. It may not be accurate for all machines covered by this manual. The wiring diagram specific to your code is pasted inside one of the enclosure panels of your machine.

SCHEMATIC - CONTROL PC BOARD

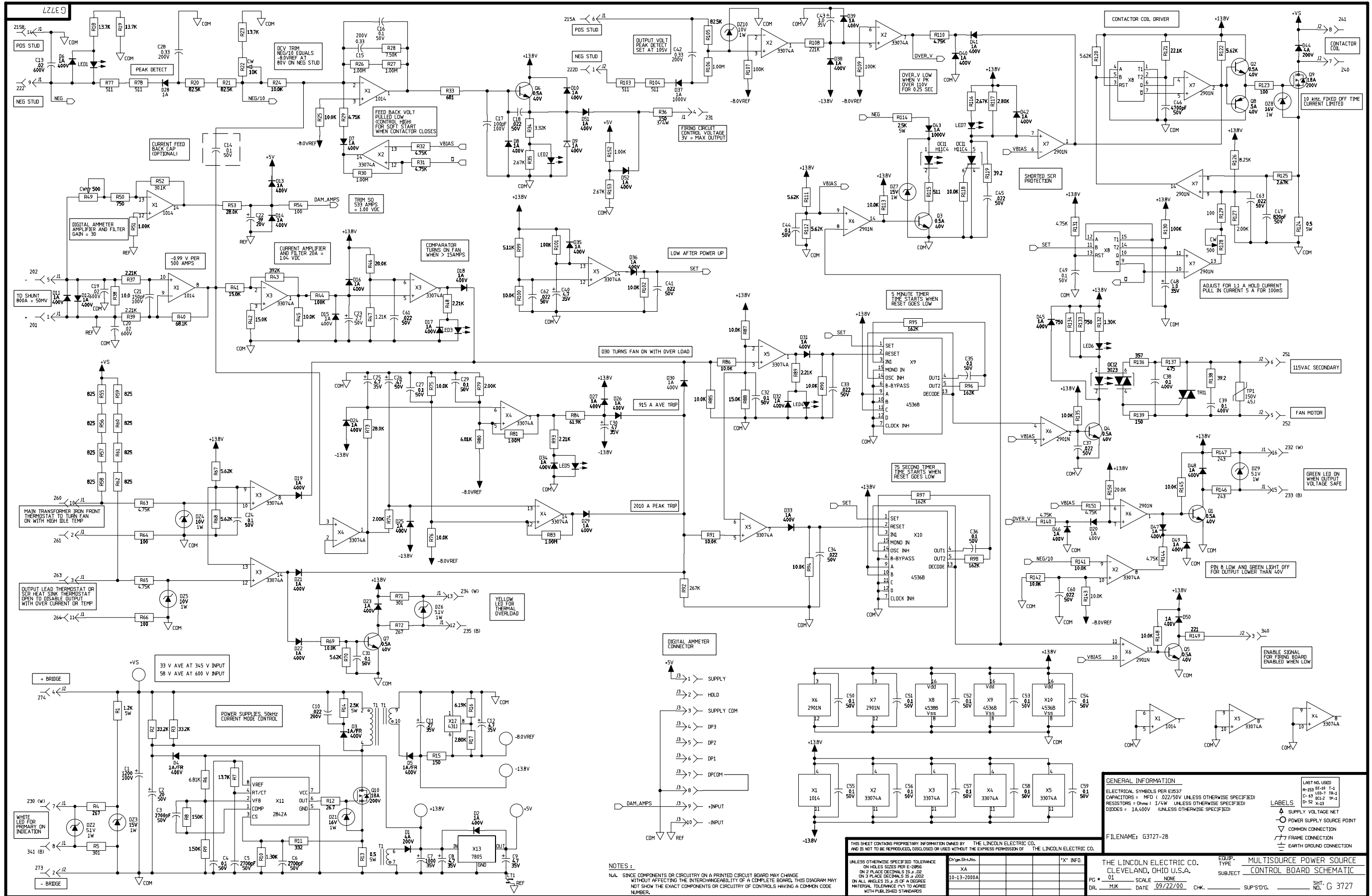

NOTE: This diagram is for reference only. It may not be accurate for all machines covered by this manual.



Return to Section TOC
Return to Master TOC
Return to Section TOC
Return to Master TOC
Return to Section TOC
Return to Master TOC
Return to Section TOC
Return to Master TOC

PC BOARD ASSEMBLY-CONTROL

Return to Section TOC
Return to Master TOC

Return to Section TOC
Return to Master TOC

Return to Section TOC
Return to Master TOC

Return to Section TOC
Return to Master TOC

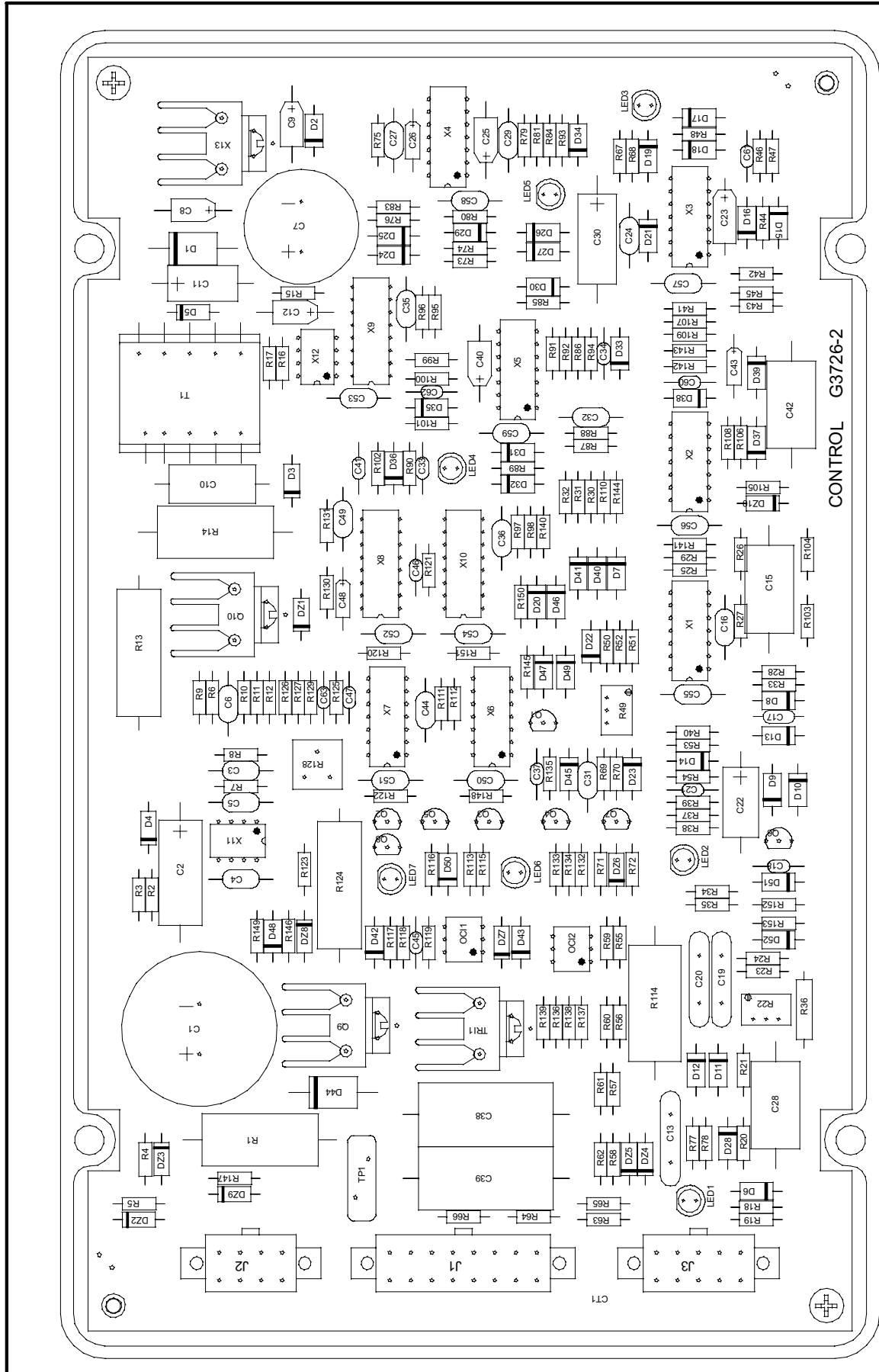

PC BOARD DESIGNATORS	ITEM	PART NO.	DESCRIPTION
R33	1	S19400-6810	RESISTOR, MF, 1/4W, 681. 1%
R34	1	S19400-3321	RESISTOR, MF, 1/4W, 3. 32K, 1%
R35, R116, R125, R153	4	S19400-2671	RESISTOR, MF, 1/4W, 2. 67K, 1%
R36	1	S24000-1500	RESISTOR, WW, 3/4W, 150. 5%
R37, R39, R48, R89, R93	5	S19400-2211	RESISTOR, MF, 1/4W, 2. 21K, 1%
R38	1	S19400-10R0	RESISTOR, MF, 1/4W, 10. 0. 1%
R40	1	S19400-6812	RESISTOR, MF, 1/4W, 68. 1K, 1%
R41, R42, R88	3	S19400-1502	RESISTOR, MF, 1/4W, 15. 0K, 1%
R43	1	S19400-3923	RESISTOR, MF, 1/4W, 392K, 1%
R44, R101, R107, R109, R130	5	S19400-1003	RESISTOR, MF, 1/4W, 100K, 1%
R46, R150	2	S19400-2002	RESISTOR, MF, 1/4W, 20. 0K, 1%
R47	1	S19400-1211	RESISTOR, MF, 1/4W, 1. 21K, 1%
R49	1	S16296-3	TRIMMER, MT, 1/2W, 500. 10%, LINEAR
R50, R133, R134	3	S19400-7500	RESISTOR, MF, 1/4W, 750. 1%
R51, R152	2	S19400-1001	RESISTOR, MF, 1/4W, 1. 00K, 1%
R52	1	S19400-3012	RESISTOR, MF, 1/4W, 30. 1K, 1%
R53, R73	2	S19400-2802	RESISTOR, MF, 1/4W, 28. 0K, 1%
R54, R64, R66, R123, R129	5	S19400-1000	RESISTOR, MF, 1/4W, 100. 1%
R55, R56, R57, R58, R59, R60	8	S19400-8250	RESISTOR, MF, 1/4W, 825. 1%
R61, R62	2	S19400-5621	RESISTOR, MF, 1/4W, 5. 62K, 1%
R67, R68, R70, R111, R112, R120	7	S19400-5621	RESISTOR, MF, 1/4W, 5. 62K, 1%
R122	1	S19400-2001	RESISTOR, MF, 1/4W, 2. 00K, 1%
R74, R79, R127	3	S19400-5110	RESISTOR, MF, 1/4W, 511. 1%
R77, R78, R103, R104, R115	5	S19400-6192	RESISTOR, MF, 1/4W, 61. 9K, 1%
R84	1	S19400-2673	RESISTOR, MF, 1/4W, 267K, 1%
R92	1	S19400-1623	RESISTOR, MF, 1/4W, 162K, 1%
R95, R96, R97, R98	4	S19400-5111	RESISTOR, MF, 1/4W, 511. 1%
R99	1	S19400-2213	RESISTOR, MF, 1/4W, 221K, 1%
R108	1	S19400-39R2	RESISTOR, MF, 1/4W, 39. 2. 1%
R119, R138	2	S19400-2212	RESISTOR, MF, 1/4W, 22. 1K, 1%
R121	1	S19400-8251	RESISTOR, MF, 1/4W, 8. 25K, 1%
R126	1	T10812-62	TRIMMER, ST, 1/2W, 500. 10%, LINEAR
R128	1	S19400-3570	RESISTOR, MF, 1/4W, 357. 1%
R137	1	S19400-4750	RESISTOR, MF, 1/4W, 475. 1%
R146, R147	2	S19400-2430	RESISTOR, MF, 1/4W, 243. 1%
R149	1	S19400-2210	RESISTOR, MF, 1/4W, 221. 1%
T1	1	S20375-1	TRANSFORMER, PCB, PWM, FLYBACK
TP1	1	T13640-11	MOV, 150V RMS, 45J, 14MM
TR1	1	S18395-27	TRIAC, T220, 8A, 800V, WITH S18104-3HS
X1	1	S15128-16	IC, OP-AMP, QUAD, HIGH-PERF, 1014
X2, X3, X4, X5	4	S15128-18	OP-AMP, QUAD, HIGH-PERF, 33074
X6, X7	2	S15128-11	IC, COMPARETOR, QUAD, 2901N
X8	1	S15018-9	IC, CMOS, MULTIVIBRTR, MONO DUAL, 4538(5S)
X9, X10	2	S15018-13	IC, CMOS, TIMER, PROGRAMMABLE, 4536(5S)
X11	1	M15458-4	IC, PWM-CONTROLLER, IMODE, 2842A
X12	1	S15128-10	VOLTAGE REF, ADJ., PRECISION, 4311
X13	1	S18395-3	REGULATOR, HEAT-SINKASBLY, S15128-5, S18104-3

UNLESS OTHERWISE SPECIFIED:
RESISTANCE = OHMS

PC BOARD DESIGNATORS	ITEM	PART NO.	DESCRIPTION
C1	1	S13490-138	CAPACITOR, ALEL, 1200, 100V, +75/-20%
C2	1	S13490-73	CAPACITOR, ALEL, 20, 50V, +75/-10%
C3, C5, C6	3	S16668-4	CAPACITOR, CEMO, 2700PF, 50V, 5%
C4, C16, C24, C27, C29, C31	22	S16668-11	CAPACITOR, CEMO, 0. 1. 50V, 10%
C32, C35, C36, C44, C49, C50			
C51, C52, C53, C54, C55, C56			
C57, C58, C59			
C7	1	S13490-121	CAPACITOR, ALEL, 1000, 35V, +30/-20%
C8, C9, C12, C25, C40	5	S13490-25	CAPACITOR, TAEL, 4. 7, 35V, 10%
C10	1	S13490-4	CAPACITOR, PEF, .022, 200V, 10%
C11	1	S13490-93	CAPACITOR, TAEL, 27, 35V, 10%
C13, C19, C20	3	T11577-38	CAPACITOR, CD, .02, 600V, +80/-20%
C15, C28, C42	3	S13490-94	CAPACITOR, PEMF, 0. 33, 200V, 10%
C17	1	S16668-3	CAPACITOR, CEMO, 100P, 100V, 5%
C18, C33, C34, C37, C41, C45	10	S16668-5	CAPACITOR, CEMO, .022, 50V, 20%
C60, C61, C62, C63			
C61	1	S16668-9	CAPACITOR, CEMO, 150p, 100V, 5%
C22	1	S13490-104	CAPACITOR, TAEL, 39, 20V, 10%
C23	1	S13490-40	CAPACITOR, TAEL, 2. 7, 50V, 10%
C26	1	S13490-63	CAPACITOR, TAEL, .47, 50V, 10%
C30	1	S13490-66	CAPACITOR, TAEL, 47, 35V, 10%
C38, C39	2	T11577-57	CAPACITOR, PEF, 0. 1, 400V, 10%
C43, C48	2	S13490-42	CAPACITOR, TAEL, 1. 0, 35V, 10%
C46	1	S16668-6	CAPACITOR, CEMO, 4700p, 50V, 10%
C47	1	S16668-7	CAPACITOR, CEMO, 820p, 50V, 5%
CT1	1	COSMETIC_TRACE	COSMETIC TRACE
D1, D44	2	T12705-47	DIODE, AXLDS, 4A, 200V, UFR
D2, D6, D7, D8, D9, D10, D11, D12	44	T12199-1	DIODE, AXLDS, 1A, 400V
D13, D14, D15, D16, D17, D18			
D19, D20, D21, D22, D23, D24			
D25, D26, D27, D29, D30, D31			
D32, D33, D34, D35, D36, D38			
D39, D40, D41, D42, D45, D46			
D47, D48, D49, D50, D51, D52			
D3, D4, D5	3	T12705-34	DIODE, AXLDS, 1A, 400V, FR, 1N4936
D28, D37, D43	3	T12199-2	DIODE, AXLDS, 1A, 1000V
D21, D28	2	T12702-11	ZENER DIODE, 1W, 16V, 5% 1N4745A
D22, D26, D29	3	T12702-52	ZENER DIODE, 1W, 5. 1V, 5% 1N4733A
D23, D27	2	T12702-29	ZENER DIODE, 1W, 15V, 5% 1N4744A
D24, D25, D210	3	T12702-27	ZENER DIODE, 1W, 10V, 5% 1N4740A
J1	1	S24020-16	CONNECTOR, MOLEX, MINI, PCB, 16-PIN, TIN
J2	1	S24020-8	CONNECTOR, MOLEX, MINI, PCB, 8-PIN, TIN
J3	1	S24020-10	CONNECTOR, MOLEX, MINI, PCB, 10-PIN, TIN
LED1, LED2, LED3, LED4, LED5	7	T13657-2	LED, T-1. 3/4, RED, HLMP-3003
LED6, LED7			
OC11	1	S15000-8	OPTOCOUPLER, PHOTO-SCR, 400V, MCS2401
OC12	1	S15000-12	OPTOCOUPLER, TRIAC DRIVER, RANDM, 3023
Q1, Q2, Q3, Q4, Q5, Q6, Q7	7	T12704-68	TRANSISTOR, NPN, TO226, 0. 5A, 40V, 2N4401
Q8	1	T12704-69	TRANSISTOR, PNP, TO226, 0. 5A, 40V, 2N4403
Q9, Q10	2	S18395-5	MOSFET/HEATSINK ASBLY, T12704-61&S18104-3(5S)
R1	1	T14648-10	RESISTOR, WW, 5W, 1. 2K, 5%, SQ
R2, R3	2	S19400-3322	RESISTOR, MF, 1/4W, 33. 2K, 1%
R4, R72	2	S19400-2670	RESISTOR, MF, 1/4W, 267. 1%
R5, R71	2	S19400-3010	RESISTOR, MF, 1/4W, 301. 1%
R6, R80	2	S19400-6811	RESISTOR, MF, 1/4W, 6. 81K, 1%
R7, R18, R19, R23	4	S19400-1372	RESISTOR, MF, 1/4W, 13. 7K, 1%
R8	1	S19400-1503	RESISTOR, MF, 1/4W, 150K, 1%
R9	1	S19400-1501	RESISTOR, MF, 1/4W, 1. 50K, 1%
R10, R132	2	S19400-1301	RESISTOR, MF, 1/4W, 1. 30K, 1%
R11	1	S19400-3320	RESISTOR, MF, 1/4W, 332. 1%
R12	1	S19400-26R7	RESISTOR, MF, 1/4W, 26. 7, 1%
R13, R124	2	T12300-80	RESISTOR, WW, 5W, 0. 5, 5%
R14, R114	2	T14648-9	RESISTOR, WW, 5W, 2. 5K, 5%, SQ
R15, R139	2	S19400-1500	RESISTOR, MF, 1/4W, 150. 1%
R16	1	S19400-6191	RESISTOR, MF, 1/4W, 6. 19K, 1%
R17, R117	2	S19400-2801	RESISTOR, MF, 1/4W, 2. 80K, 1%
R20, R21, R105	3	S19400-8252	RESISTOR, MF, 1/4W, 82. 5K, 1%
R22	1	S16296-5	TRIMMER, MT, 1/2W, 10K, 10%, LINEAR
R24, R25, R45, R69, R75, R76	22	S19400-1002	RESISTOR, MF, 1/4W, 10. 0K, 1%
R85, R86, R87, R90, R91, R94			
R100, R102, R113, R118, R135			
R141, R142, R143, R145, R148			
R26, R27, R30, R81, R83, R106	6	S19400-1004	RESISTOR, MF, 1/4W, 1. 00M, 1%
R28	1	S19400-7501	RESISTOR, MF, 1/4W, 7. 50K, 1%
R29, R31, R32, R63, R65, R110	10	S19400-4751	RESISTOR, MF, 1/4W, 4. 75K, 1%
R131, R140, R144, R151			

Chg. Sheet No.	XB	INFO.	DESIGN INFORMATION	REFERENCE	EQUIPMENT TYPE:	MULTI-SOURCE
10-13-2000A			DRAWN BY: MELS	G3726-1	SUBJECT:	CONTROL P.C. BOARD ASSEMBLY
			ENGINEER: MJK	SUPERSEDED	SCALE: 1:1	DATE: 4-20-2000 DRAWING No: G 3726-2
			APPROVED:			

NOTE: Lincoln Electric assumes no responsibility for liabilities resulting from board level troubleshooting. PC Board repairs will invalidate your factory warranty. Individual Printed Circuit Board Components are not available from Lincoln Electric. This information is provided for reference only. Lincoln Electric discourages board level troubleshooting and repair since it may compromise the quality of the design and may result in danger to the Machine Operator or Technician. Improper PC board repairs could result in damage to the machine.



PC BOARD ASSEMBLY-FIRING

Return to Section TOC
Return to Master TOC

Return to Section TOC
Return to Master TOC

Return to Section TOC
Return to Master TOC

Return to Section TOC
Return to Master TOC

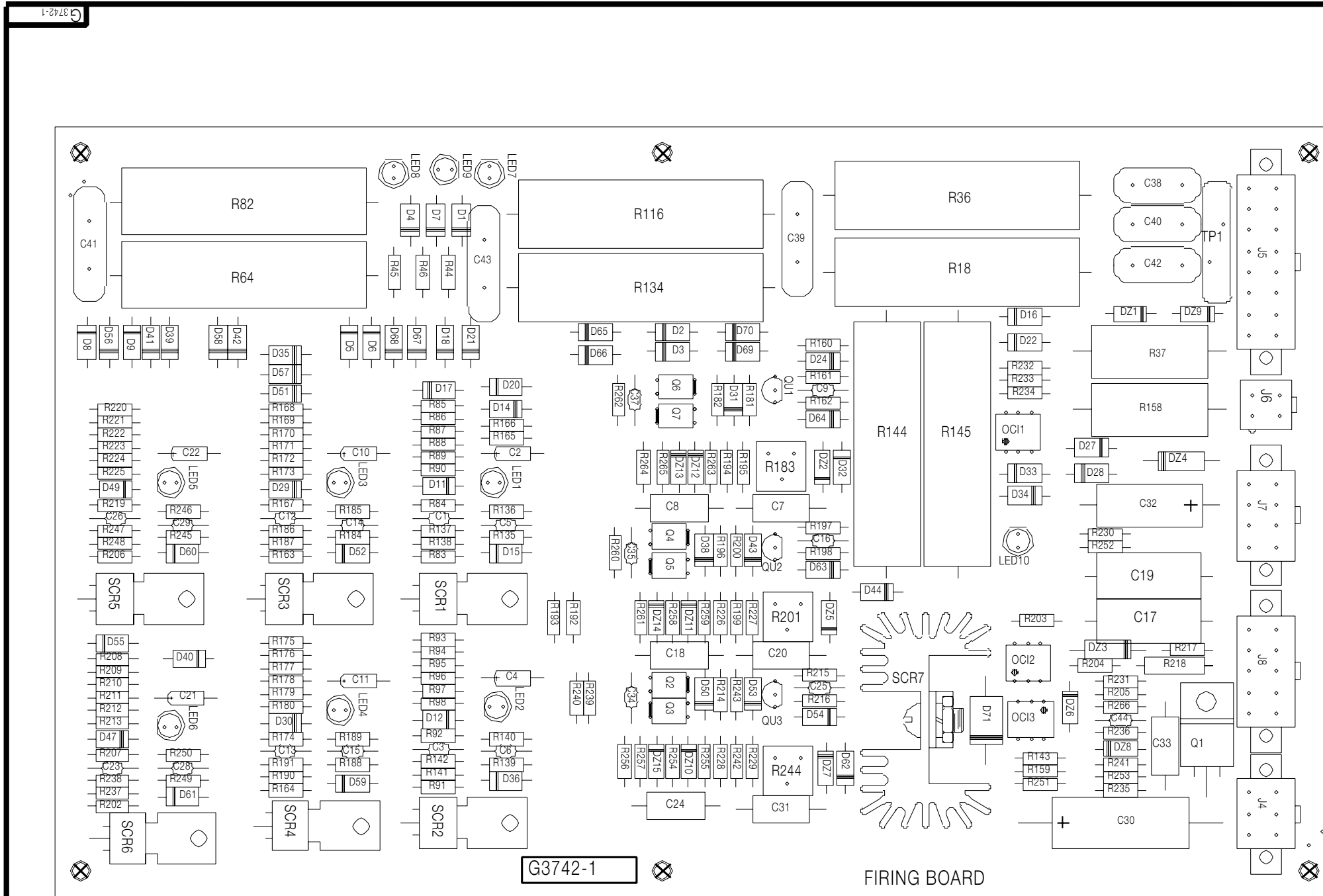

ITEM	REQ'D	PART NO.	DESCRIPTION
C1,C3,C5,C6,C9,C12,C13,C14	19	S16668-5	.022/50
C15,C16,C23,C25,C26,C28			
C29,C34,C36,C37,C44			
C2,C4,C10,C11,C21,C22	6	S13490-95	33/50
C7,C8,C18,C20,C24,C31,C33	7	S13490-108	15/100
C17,C19	2	T11577-41	.022/400
C30	1	S13490-74	10/150
C32	1	S13490-73	20/50
C38,C40,C42	3	T11577-58	.0047/3000V
C39,C41,C43	3	T11577-46	.05/600V
D1,D4,D7,D11,D12,D14,D15	34	T12199-1	1N4004
D24,D27,D28,D29,D30,D31			
D32,D33,D34,D35,D36,D38,D43			
D44,D47,D49,D50,D51,D52,D53			
D54,D59,D60,D61,D62,D63,D64			
D2,D3,D5,D6,D8,D5,D16,D17	26	T12199-2	1N4007
D18,D20,D21,D22,D39,D40,D41			
D42,D55,D56,D57,D58,D65,D66			
D67,D68,D69,D70			
D71	1	T12705-46	1000V/3AMP DIODE
DZ1,D26,D29	3	T12702-52	1N4733A
DZ2,D25,D27	3	T12702-4	1N4747
DZ3	1	T12702-25	1N5357B
DZ4	1	T12702-33	1N5347B
DZ8,DZ10,DZ11,DZ12,DZ13	7	T12702-29	1N4744A
DZ14,DZ15			
J4	1	S24020-6	HEADER, VERTICAL
J5	1	S24020-16	HEADER, VERTICAL
J6	1	S18248-4	HEADER
J7	1	S24020-8	HEADER, VERTICAL
J8	1	S24020-10	HEADER, VERTICAL
LED1,LED2,LED3,LED4,LED5	10	T13657-2	RED LED
LED6,LED7,LED8,LED9,LED10			
OC1,OC3	2	S15000-10	OPTO ISOLATOR
OC2	1	S15000-12	OPTO TRIAC DRIVER
Q1	1	T12704-80	HEXFET TRANS. (SS)
Q2,Q3,Q4,Q5,Q6,Q7	6	T12704-73	IG PKG MOSFET (SS)
QU1,QU2,QU3	3	T12707-4	2N6027
R18,R36,R64,R82,R116,R134	6	T14850-6	RESISTOR WW,15W,5%,50
R37	1	T14848-15	700 5W
R44,R45,R46,R195,R227,R229	13	S19400-1002	10K 1/4W
R251,R254,R255,R258,R259			
R262,R263			
R83,R91,R135,R139,R163	13	S19400-1500	150 1/4W
R164,R184,R188,R202,R203			
R206,R245,R249			
R84,R92,R167,R174,R207,R219	6	S19400-1001	1K 1/4W
R85,R86,R87,R88,R89,R90	38	S19400-2000	200 1/4W
R93,R94,R95,R96,R97,R98			
R143,R168,R169,R170,R171			
R172,R173,R175,R176,R177			
R178,R179,R180,R208,R209			
R210,R211,R212,R213,R220			
R221,R222,R223,R224,R225			
R266			
R136,R140,R160,R185,R189	9	S19400-2670	267 1/4W
R196,R214,R246,R250			
R137,R138,R141,R142,R186	13	S19400-10R0	10 1/4W
R187,R190,R191,R237,R238			
R247,R248,R253			
R144,R145	2	T14650-1	1500 OHMS, 15W, RES
R158	1	T14648-1	5K 5W
R159,R234,R241	3	S19400-1003	100K 1/4W
R161,R187,R215	3	S19400-3323	332K 1/4W
R162,R198,R216	3	S19400-2671	2.67K 1/4W
R165,R166,R192,R193,R239	6	S19400-6190	619 1/4W
R240			
R181,R199,R205,R231,R242	5	S19400-1501	1.5K 1/4W
R182,R200,R243	3	S19400-4750	475 1/4W
R183,R201,R244	3	T10812-67	100K 1/2W TRIMMER
R194,R226,R228	3	S19400-33R2	33.2 1/4W
R204,R235	2	S19400-1000	100 1/4W
R217,R232,R233	3	S19400-39R2	39.2 1/4W
R218	1	S24000-66R0	66 3/4W
R230	1	S19400-2001	2.0K 1/4W
R236	1	S19400-2002	20K 1/4W
R252	1	S19400-3321	3.32K 1/4W
R256,R260,R264	3	S19400-8251	8.25K 1/4W
R257,R261,R265	3	S19400-2211	2.21K 1/4W
SCR1,SCR2,SCR3,SCR4,SCR5	6	S15161-19	4A, 400V, SCR
SCR6			
SCR7	1	S18395-21	SCR HS ASBLY
TP1	1	T13840-25	MOV, 90J

CAPACITORS = MFD/VOLTS
RESISTORS = OHMS

NOTE: Lincoln Electric assumes no responsibility for liabilities resulting from board level troubleshooting. PC Board repairs will invalidate your factory warranty. Individual Printed Circuit Board Components are not available from Lincoln Electric. This information is provided for reference only. Lincoln Electric discourages board level troubleshooting and repair since it may compromise the quality of the design and may result in danger to the Machine Operator or Technician. Improper PC board repairs could result in damage to the machine.



UNLESS OTHERWISE SPECIFIED TOLERANCES:
ON HOLE SIZES PER E-2058
ON 2 PLACE DECIMALS IS +.00
ON 3 PLACE DECIMALS IS +.002
ON ALL DIMENSIONS IS +.004 SQUARE
MATERIAL TOLERANCE IS TO AGREE
WITH QUANTITY RELATIONS

THE LINCOLN ELECTRIC CO. CLEVELAND, OHIO U. S. A.
SCALE: FULL

DC-600/MULTI-SOURCE
FIRING P.C. BOARD ASSEMBLY

3742-1

PC BOARD ASSEMBLY - SNUBBER

Return to Section TOC
Return to Master TOC

Return to Section TOC
Return to Master TOC

Return to Section TOC
Return to Master TOC

Return to Section TOC
Return to Master TOC

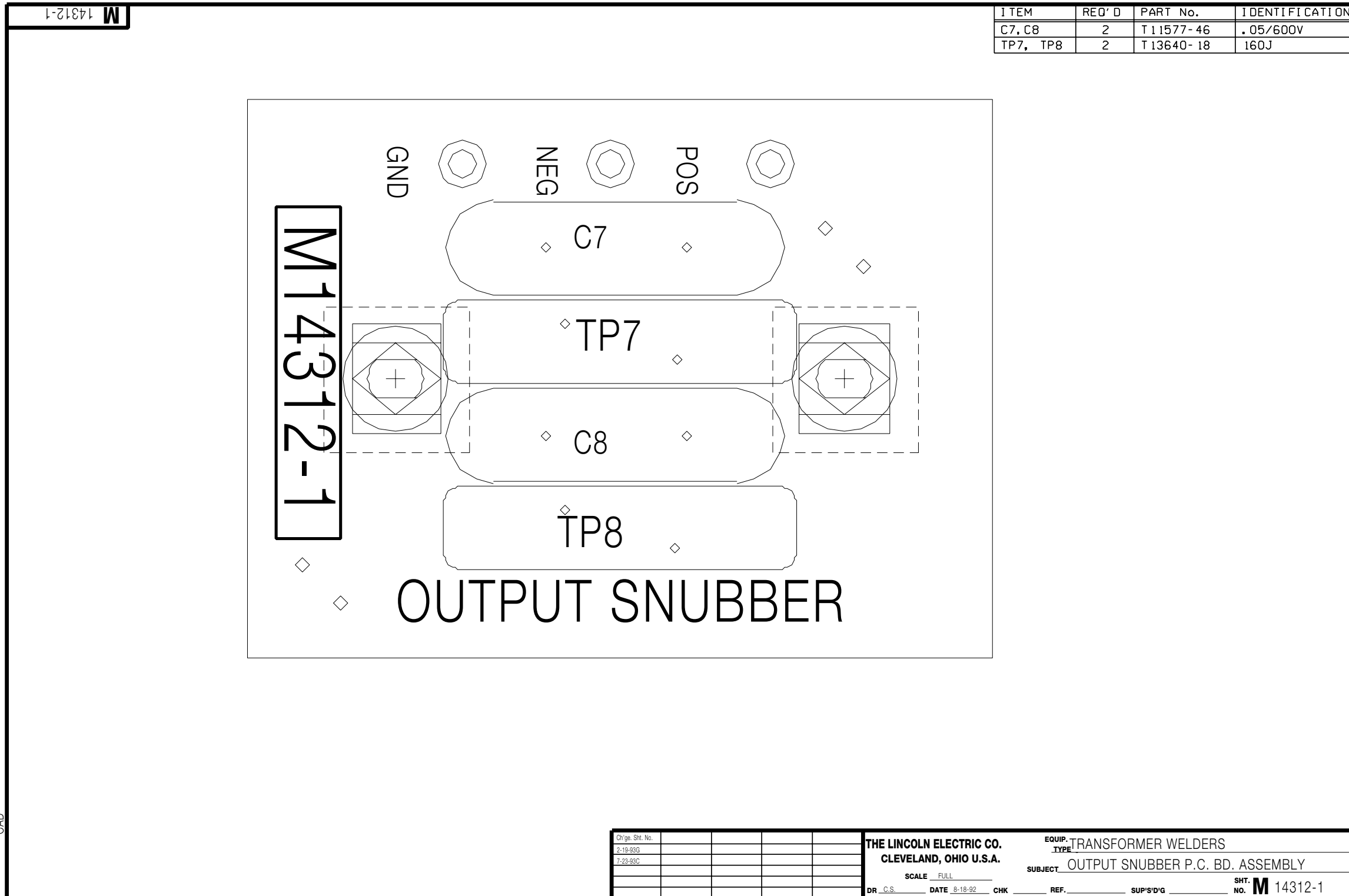

NOTE: Lincoln Electric assumes no responsibility for liabilities resulting from board level troubleshooting. PC Board repairs will invalidate your factory warranty. **Individual Printed Circuit Board Components are not available from Lincoln Electric.** This information is provided for reference only. Lincoln Electric discourages board level troubleshooting and repair since it may compromise the quality of the design and may result in danger to the Machine Operator or Technician. Improper PC board repairs could result in damage to the machine.



SVM ERROR REPORTING FORM

We need to know if there are errors in our manuals. We also value any suggestions as to additional tests or procedures that would make this SVM a better tool for you.

If you discover new or different "Problems or Symptoms" that are not covered in the three column troubleshooting chart, please share this information with us. Please include the machine's code number and how the problem was resolved.

Thank You,
Technical Services Group
Lincoln Electric Co.
22801 ST. Clair Ave.
Cleveland, Ohio 44117-1199

FAX 216-481-2309

SVM Number _____

Page Number if necessary _____

Your Company _____

Your Name _____

Please give detailed description below:

SD287 01/99

