

# OPERATING MANUAL

## LN-7 SEMI-AUTOMATIC WIRE FEEDER

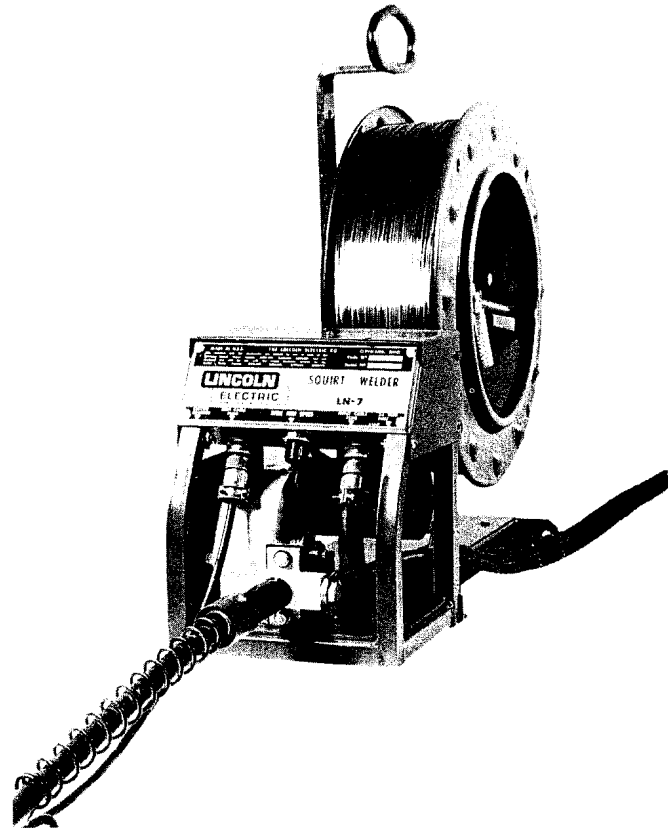

This manual covers equipment which is obsolete and no longer in production by The Lincoln Electric Co. Specifications and availability of optional features may have changed.

### Shipping Damage Claims

When this equipment is shipped, title passes to the purchaser upon receipt by the carrier. Consequently, claims for material damaged in shipment must be made by the purchaser against the transportation company at the time the shipment is received.

### Safety Depends On You

Lincoln arc welding equipment is designed and built with safety in mind. However, your overall safety can be increased by proper installation . . . and thoughtful operation on your part. **DO NOT INSTALL, OPERATE OR REPAIR THIS EQUIPMENT WITHOUT READING THIS OPERATING MANUAL AND THE ARC WELDING SAFETY PRECAUTIONS ON THE INSIDE FRONT COVER.** And, most importantly, think before you act and be careful.

# Arc Welding Safety Precautions

**PROTECT YOURSELF AND OTHERS FROM POSSIBLE SERIOUS INJURY OR DEATH. READ AND UNDERSTAND BOTH THE SPECIFIC INFORMATION GIVEN IN THE OPERATING MANUAL FOR THE WELDER AND/OR OTHER EQUIPMENT TO BE USED AS WELL AS THE FOLLOWING GENERAL INFORMATION.**

1. HAVE ALL INSTALLATION, OPERATION, MAINTENANCE AND REPAIR WORK performed only by qualified people.

2. ELECTRIC SHOCK can kill.

Protect yourself from possible dangerous electrical shock:

- a. The electrode and work (or ground) circuits are electrically "hot" when the welder is on. Never permit contact between "hot" parts of the circuits and bare skin or wet clothing. Wear dry, hole-free gloves to insulate hands.
- b. Always insulate yourself from the work and ground by using dry insulation. When welding in damp locations, on metal floors, gratings or scaffolds, and when in positions such as sitting or lying, make certain the insulation is large enough to cover your full area of physical contact with work and ground.
- c. Always be sure the work cable makes a good electrical connection with the metal being welded. The connection should be as close as possible to the area being welded.
- d. Ground the work or metal to be welded to a good electrical ground.
- e. Maintain the electrode holder, work clamp, welding cable and welding machine in good, safe operating condition.
- f. Never dip the electrode in water for cooling.
- g. Never simultaneously touch electrically "hot" parts of electrode holders connected to two welders because voltage between the two can be the total of the open circuit voltage of both welders.
- h. If using the welder as a power source for mechanized welding, the above precautions also apply for the automatic electrode, electrode reel, welding head, nozzle or semiautomatic welding gun.
- i. When working above floor level, protect yourself from a fall should you get a shock.
- j. Also see Items 6c and 8.

3. FUMES AND GASES can be dangerous to your health.

- a. Welding may produce fumes and gases hazardous to health. Avoid breathing these fumes and gases. When welding, keep your head out of the fume. Use enough ventilation and/or exhaust at the arc to keep fumes and gases away from the breathing zone. When welding on galvanized, lead or cadmium

plated steel and other metals which produce toxic fumes, even greater care must be taken.

- b. Do not weld in locations near chlorinated hydrocarbon vapors coming from degreasing, cleaning or spraying operations. The heat and rays of the arc can react with solvent vapors to form phosgene, a highly toxic gas, and other irritating products.
- c. Shielding gases used for arc welding can displace air and cause injury or death. Always use enough ventilation, especially in confined areas, to insure breathing air is safe.
- d. Read and understand the manufacturer's instructions for this equipment and the consumables to be used, including the material safety data sheet (MSDS) and follow your employer's safety practices.
- e. Also see item 9b.

4. ARC RAYS can injure eyes and burn skin.

- a. Use a shield with the proper filter and cover plates to protect your eyes from sparks and the rays of the arc when welding or observing open arc welding. Headshield and filter lens should conform to ANSI Z87.1 standards.
- b. Use suitable clothing made from durable, flame-resistant material to protect your skin and that of your helpers from the arc rays.
- c. Protect other nearby personnel with suitable non-flammable screening and/or warn them not to watch the arc nor expose themselves to the arc rays or to hot spatter or metal.

5. FIRE OR EXPLOSION can cause death or property damage.

- a. Remove fire hazards well away from the area. If this is not possible cover them to prevent the welding sparks from starting a fire. Remember that welding sparks and hot materials from welding can easily go through small cracks and openings to adjacent areas. Have a fire extinguisher readily available.
- b. Where compressed gases are to be used at the job site, special precautions should be used to prevent hazardous situations. Refer to "Safety in Welding and Cutting" (ANSI Standard Z49.1) and the operating information for the equipment being used.
- c. When not welding, make certain no part of the electrode circuit is touching the work or ground. Accidental contact can cause overheating and create a fire hazard.

- d. Do not heat, cut or weld tanks, drums or containers until the proper steps have been taken to insure that such procedures will not cause flammable or toxic vapors from substances inside. They can cause an explosion even though they have been "cleaned." For information purchase "Recommended Safe Practices for the Preparation for Welding and Cutting of Containers and Piping That Have Held Hazardous Substances.", AWS F4.1-80 from the American Welding Society (see address below).
  - e. Vent hollow castings or containers before heating, cutting or welding. They may explode.
  - f. Also see items 6c and 9c.
6. For Welding in General.
- a. Droplets of molten slag and metal are thrown or fall from the welding arc. Protect yourself with oil free protective garments such as leather gloves, heavy shirt, cuffless trousers, high shoes and a cap over your hair. Wear ear plugs when welding out of position or in confined places. Always wear safety glasses when in a welding area. Use glasses with side shields when near slag chipping operations.
  - b. Keep all equipment safety guards, covers and devices in position and in good repair. Keep hands, hair, clothing and tools away from V-belts, gears, fans and all other moving parts when starting, operating or repairing equipment.
  - c. Be sure the work cable is connected to the work as close to the welding area as practical. Work cables connected to the building framework or other locations some distance from the welding area increase the possibility of the welding current passing through lifting chains, crane cables or other alternate circuits. This can create fire hazards or overheat lifting chains or cables until they fail.
7. For Gas-Shielded Arc Welding.
- a. Use only compressed gas cylinders containing the correct shielding gas for the process used and properly operating regulators designed for the gas and pressure used. All hoses, fittings, etc. should be suitable for the application and maintained in good condition.
  - b. Always keep cylinders in an upright position securely chained to an undercarriage or fixed support.
  - c. Cylinders should be located:
    - Away from areas where they may be struck or subjected to physical damage.
    - A safe distance from arc welding or cutting operations and any other source of heat, sparks, or flame.
  - d. Never allow the electrode, electrode holder, or any other electrically "hot" parts to touch a cylinder.
  - e. Keep your head and face away from the cylinder valve outlet when opening the cylinder valve.
- f. Valve protection caps should always be in place and handtight except when the cylinder is in use or connected for use.
  - g. Read and follow the instructions on compressed gas cylinders, associated equipment, and CGA publication P-1 "Precautions for Safe Handling of Compressed Gases in Cylinders" available from the Compressed Gas Association, 1235 Jefferson Davis Highway, Arlington, VA 22202.
8. For Electrically Powered Equipment.
- a. Turn off input power using the disconnect switch at the fuse box before working on the equipment.
  - b. Make the electrical installation in accordance with the National Electrical Code, all local codes and the manufacturer's recommendations.
  - c. Properly ground the equipment in accordance with the National Electrical Code and the manufacturer's recommendations.
9. For Engine Powered Equipment.
- a. Turn the engine off before troubleshooting and maintenance work unless the maintenance work requires it to be running.
  - b. Operate the internal combustion engines in open, well-ventilated areas or vent the engine exhaust fumes outdoors.
  - c. Do not add the fuel near an open flame, welding arc or when the engine is running. Stop the engine and, if possible, allow it to cool when refueling to prevent spilled fuel from vaporizing on contact with hot engine parts and igniting. Do not spill fuel when filling tank. If fuel is spilled, wipe it up and do not start engine until fumes have been eliminated.
  - d. In some cases it may be necessary to remove safety guards to perform required maintenance. Remove guards only when necessary and replace them when the maintenance requiring their removal is complete. Always use the greatest care when working near moving parts.
  - e. Do not put your hands near the engine fan. Do not attempt to override the governor or idler by pushing on the throttle control rods while the engine is running.
  - f. To prevent accidentally starting gasoline engines while turning the engine or welding generator during maintenance work, disconnect the spark plug wires, distributor cap or magneto wire as appropriate.
  - g. To avoid scalding, do not remove the radiator pressure cap when the engine is hot.
- For more detailed information it is strongly recommended that you purchase a copy of "Safety in Welding & Cutting — ANSI Standard Z49.1" from the American Welding Society, P.O. Box 351040 Miami, Florida 33135.

## **Need Welding Training?**

The Lincoln Electric Company operates the oldest and most respected Arc Welding School in the United States at its corporate headquarters in Cleveland, Ohio. Over 60,000 students have graduated. Tuition is low and the training is "hands on".

For details write: Lincoln Welding School  
22801 St. Clair  
Cleveland, Ohio 44117

and ask for bulletin ED-80 or call 216-481-8100 and ask for the Welding School Registrar.

## SEC. J1 INDEX

### Sec. J2 INSTALLATION INSTRUCTIONS

Wire Feed Unit and Wire Reel . . . . .	Sec. J2.2.1
Wire Feed Rolls and Guide Tubes . . . . .	Sec. J2.2.2
Gun & Gun Cable Assemblies . . . . .	Sec. J2.2.3
Input Cable: LN-7 to Power Source . . . . .	Sec. J2.3.1
Connection Diagrams: LN-7 to Lincoln Power Sources . . . . .	Sec. J2.3.2
Connection Diagrams: LN-7 to Other Power Sources . . . . .	Sec. J2.3.3
Optional Feature Installation	
K-178 Mounting Platform . . . . .	Sec. J2.5.3
Auxiliary Equipment Contacts . . . . .	Sec. J2.5.5
K-162 Spindle for Mounting 10 thru 30 Pound Spools . . . . .	Sec. J2.5.7
K-163 Undercarriage . . . . .	Sec. J2.5.8

### Sec. J3 OPERATING INSTRUCTIONS

Adjusting Current and Voltage . . . . .	Sec. J3.1.1
Arc Starting . . . . .	Sec. J3.1.2
Circuit Protection . . . . .	Sec. J3.1.4
Wire Reel Loading — 50 and 60 Pound Coils . . . . .	Sec. J3.1.5
Wire Reel Loading — 10 to 30 Pound Spools . . . . .	Sec. J3.1.6
Sequence of Welding . . . . .	Sec. J3.1.7
Wire Reel Changing . . . . .	Sec. J3.1.9

For Innershield® operating techniques and procedures request  
"Innershield Production Welding Guide", bulletin N675

### Sec. J6 MAINTENANCE

Wire Drive Motor and Gear Box . . . . .	Sec. J6.1.1
Drive Rolls and Guide Tubes . . . . .	Sec. J6.1.2
Wire Reel Mounting . . . . .	Sec. J6.1.3
Control Box . . . . .	Sec. J6.1.5
Gun Cable . . . . .	Sec. J6.2.1
Gun Disassembly — K-115 and K-126 . . . . .	Sec. J6.2.2
Electrical Sequence of Operation . . . . .	Sec. J6.4
Troubleshooting . . . . .	Sec. J6.6

Parts Lists . . . . .	Sec. J7
-----------------------	---------

Wiring Diagrams . . . . . Filed at the back of this manual.

January 1976



## SEC. J2.2 MECHANICAL INSTALLATION

### Sec. J2.2.1

#### Wire Feed Unit and Wire Reel

The LN-7 is shipped ready to install in the work location.

September 1971

### Sec. J2.2.2

#### Wire Feed Rolls and Guide Tubes

NOTE: The maximum sizes the LN-7 will satisfactorily feed are 7/64" Innershield® and 3/32" solid electrodes.

The drive roll, idle roll and guide tubes for the electrode size specified on the order is shipped with the wire feed unit. The electrode sizes that can be fed with each roll and guide tube are stenciled on each part. Instructions to install these parts on new machines or replace them on used machines, are as follows:

- A. Loosen the idle roll tension nut (item 28) approximately 3 full turns or use a screwdriver to pry the idle roll arm down at point B.
- B. Remove hex head screw (item 3) & the drive roll clamping collar (item 4). (On new machines remove the tape & drive roll key from the collar.) Insert the key (item 5) into the keyway of the output shaft.
- C. Wipe the drive roll & spacer surfaces clean. Install one drive roll (item 2), then the spacer & the second drive roll. (For .030, .035 & .045 electrode, the drive roll is one piece. For 1/16 electrode there is no spacer).
- D. Install drive roll clamping collar & hex head screw previously removed. Tighten hex head screw securely.
- E. Back out the two guide tube clamping set screws (item 29).
- F. Insert the outgoing guide (item 7) (the one with the plastic insert) into the front hole. The guide tube for .030", .035" and .045" wire has a non-symmetrical chisel end. Be certain the contour with the larger radius and the exposed oval opening for the wire faces the grooved

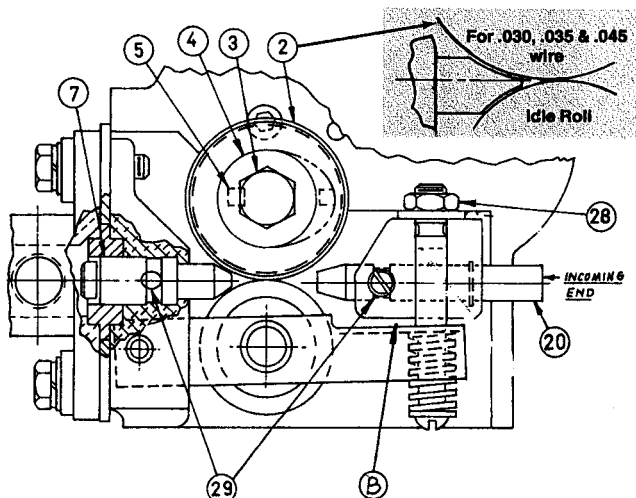

drive roll. Push the guide tube back as far as it will go and tighten the clamping set screw. Insert the incoming guide tube (item 20) into the rear hole as far as it will go and tighten the clamping set screw. These set screws are dog point. When the two tubes are installed properly these dog points will lock into the annular grooves that are in each of the guide tubes.

- G. Tighten the idle roll tension nut (item 28) or remove the screwdriver used as a wedge in step A. The tension nut should normally be tightened until it bottoms for wire sizes 1/16" and larger. For smaller wire sizes and aluminum wire the tension nut should be loosened if the wire tends to buckle in the guide tube, cable or between the drive rolls and outgoing guide tube.
- H. To change drive rolls and guide tubes for a different size, reverse the above procedure.

September 1976

### Sec. J2.2.3

#### Gun & Gun Cable Assemblies

##### General

The LN-7 is used with various guns. In all cases the gun and cable are shipped assembled ready to weld. Use the gun and cable assembly for the electrode type (solid or Innershield) and electrode size to be used.

Note: The guns described below were available at the time this sheet was printed. They may not be today. See Lincoln Specification literature for up-to-date information.

##### Innershield® Guns

Squirtgun K-126 is recommended for most welding with .062 through 3/32" electrodes. Install the insulated nozzle extension (or thread protector) and the nozzle contact tip for the stickout and electrode size being used.

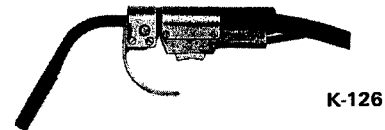

For heavy duty welding with 3/32" electrode use K-115-3/32 or K-115-45-3/32. Install a 3/32" contact tip and the insulated nozzle extension for the stickout being used.

For welding with 7/64" electrode, use K-115-3/32 with a M-11474-.120 nozzle or a K-115-45-3/32 with a M-11510-.120 nozzle. Also install a 7/64" contact tip and the insulated nozzle extension for the stickout being used.



Sec. J2.2.3 Continued

**Gun Cable: LN-7 to Gun**

Lay the cable out straight. Insert the connector on the welding conductor cable into the brass block on the front of the LN-7. Make sure it is all the way in and tighten the locking screw with a 3/16" Allen Wrench. Keep this connection clean and bright. Insert the control cable polarized plug into the receptacle below the nameplate.

**Linconditioner™ Guns**

For locations where smoke accumulation is a problem and conventional exhaust systems are ineffective, the available smoke removal type Innershield guns and vacuum units can be used. Instructions are shipped with the equipment.

April 1974

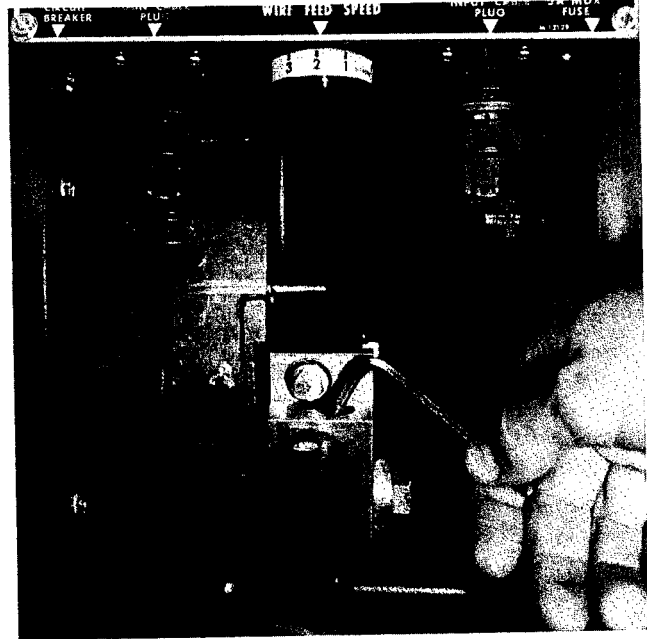

## SEC. J2.3 ELECTRICAL INSTALLATION

### Sec. J2.3.1

#### Input Cable: LN-7 to Power Source

The input cable between the wire feeder and the power source consists of a four-conductor control cable and an electrode cable. The control cable has lugged leads on the power source end and a polarized plug on the wire feeder end. **With the power source turned off**, install the input cable per the following instructions:

1. Connect the end of the control cable with the lugged leads to a constant voltage type power source. For Lincoln power sources follow exactly the instructions (including all jumpers on the power source terminal strips) for the specific power source per the wiring diagrams in Sec. J2.3.2.

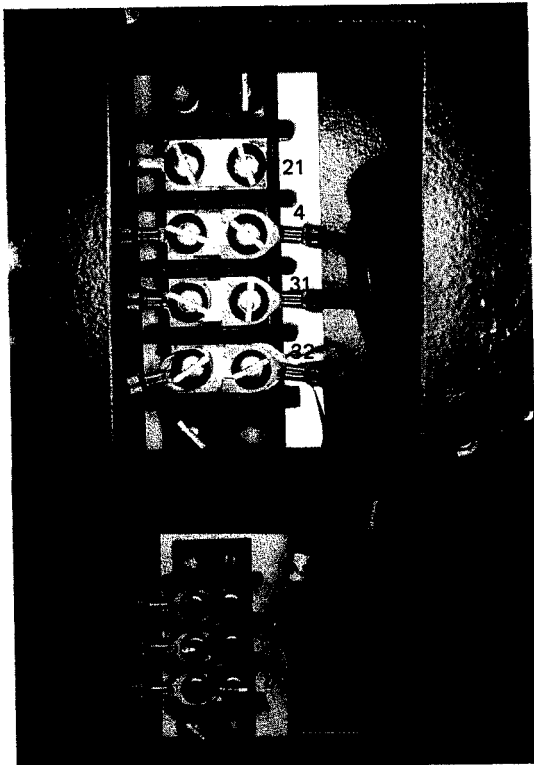

2. For constant voltage power sources not included in Sec. J2.3.2, request a copy of Sec. J2.3.3 for connection instructions.
3. If input cables longer than the standard length (available as 7, 25, 50, 75 and 100' lengths) must be used, 50' K-177 extension cables can be installed. These have polarized plugs on each end of the control cable and a 4/0 electrode cable. Install the extensions between the standard input cable and the wire feeder. Total input

lead length should not exceed 400'. When using the longer lengths of extension cables, it may be necessary to add parallel electrode cables to limit the voltage drop in the cable.

4. Loosen the screws holding the clamp to the rear vertical support of the wire feeder frame. Put only the electrode cable under the clamp.
5. Connect the end of the electrode cable to the end of the brass block on the wire feeder using the bolt provided. **Be sure the cable is placed to allow easy access to the drive roll and guide tube screws.** (See photo below.) Tighten the screws on the electrode cable clamp.
6. Run the control cable under the wire feed motor and insert the plug into the mating receptacle below the LN-7 nameplate.
7. Connect a ground lead of sufficient size and length (per the following table) between the 'To Work' stud on the power source and the work. Be sure the connection to the work makes tight metal-to-metal contact.

Current Amps 60% Duty Cycle	Copper Ground Cable Length	
	Up to 50'	50' - 100'
300	0	00
400	00	000
500	00	000
600	000	0000

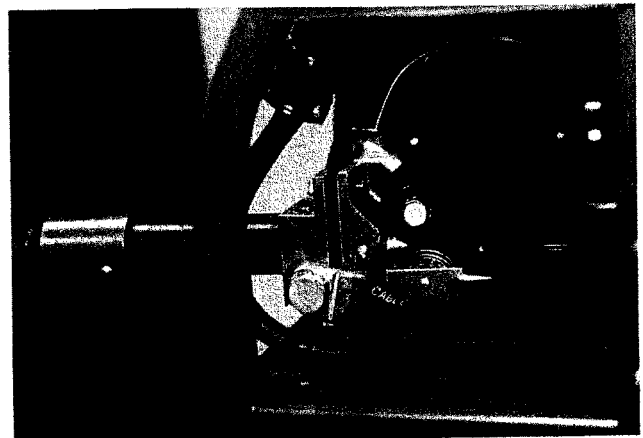

September 1976

Sec. J2.3.2  
**Connection Diagrams:**  
**LN-7 to Lincoln Power Sources**

The Lincoln Electric Company  
 Cleveland, Ohio 44117

**To an Idealarc R3S-250**

S-14671  
 6-25-71

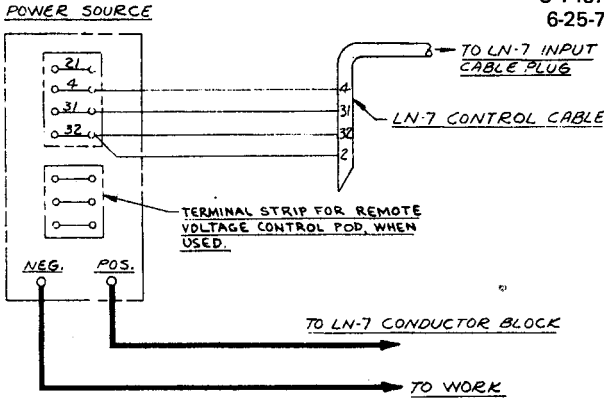
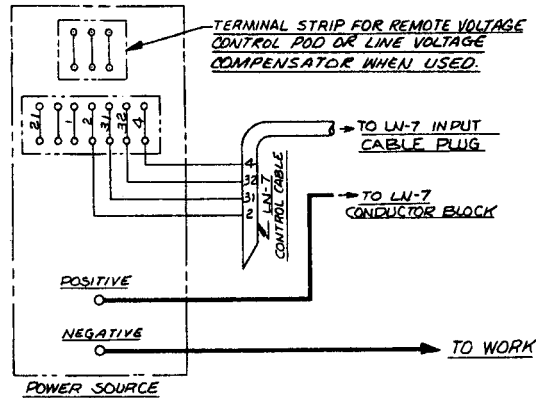

DIAGRAM SHOWS ELECTRODE CONNECTED POSITIVE. TO CHANGE POLARITY, REVERSE THE ELECTRODE AND WORK LEADS AT THE POWER SOURCE.

**To an Idealarc R3S-400, 600 or 800 Welder**

S-14179  
 6-27-75



ABOVE DIAGRAM SHOWS ELECTRODE CONNECTED POSITIVE. TO CHANGE POLARITY, REVERSE THE ELECTRODE AND WORK LEADS AT THE POWER SOURCE.

**To a SAN Welder**

S-14176  
 6-25-71

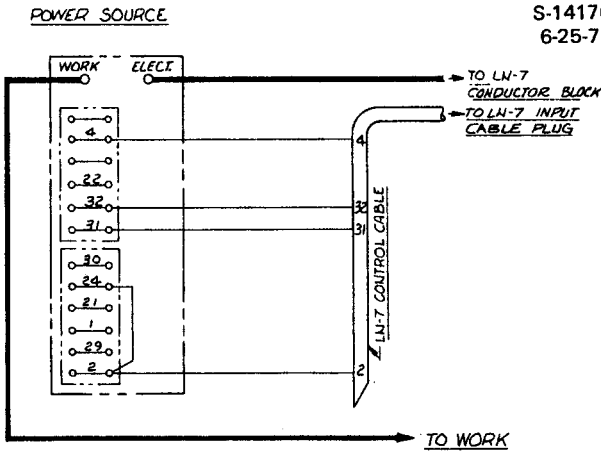

**To a SAM Motor-Generator or Engine Welder**

S-14177  
 9-24-76B

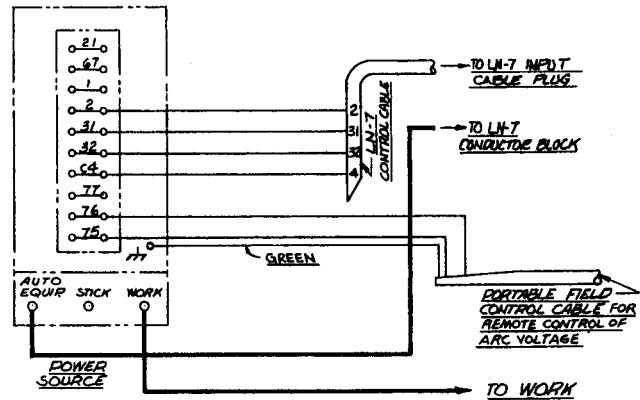

**To Power Sources Without Output Contactor Requiring A K-240 Contactor Kit**

S-15416  
 6-18-76

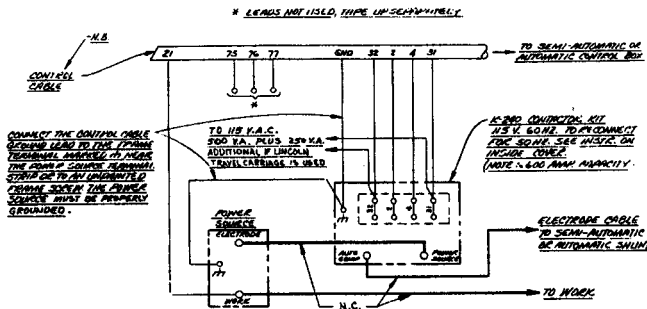

NA. 115 V.A.C. WILL NOT BE TURNED OFF WHEN POWER SOURCE IS TURNED OFF. CONTACTOR KIT AND SEMI-AUTOMATIC OR AUTOMATIC EQUIPMENT WILL STILL HAVE 115 V. CONTROL POWER SUPPLIED UNTIL POWER SUPPLIED TO TERMINALS #31 AND #32 IS TURNED OFF.

N.B. LEADS #21, #75, #76, #77, & 6HD. DO NOT APPEAR ON THE LN-7 CONTROL CABLE.

N.C. WELDING CABLES MUST BE OF PROPER CAPACITY FOR THE CURRENT AND DUTY CYCLE OF IMMEDIATE AND FUTURE APPLICATIONS.

**To a SAF-600, SA-800 or SAF-600-B ("OA") Welder**

S-14180  
 6-25-71

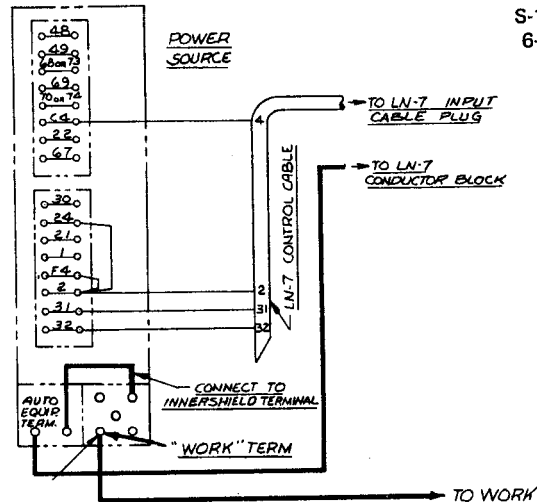

## ELECTRICAL INSTALLATION — CONT'D

Sec. J2.3.3

Connection of LN-7 to Other (Not included in Sec. J2.3.2) Power Sources

### OTHER POWER SOURCES

REFER TO WIRING DIAGRAM OF POWER SOURCE TO BE USED TO FIND THE TYPE OF CONTACTOR CIRCUIT

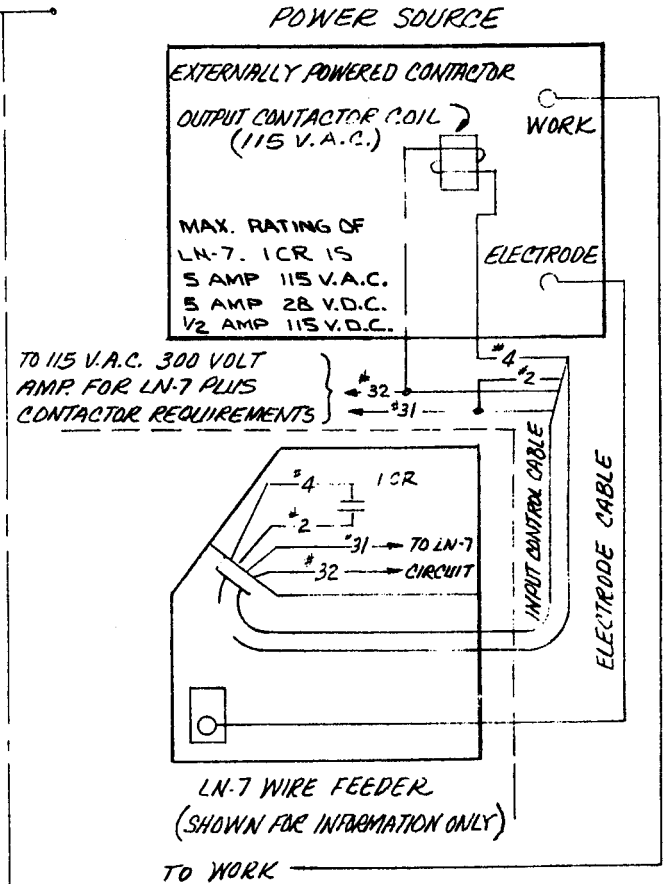
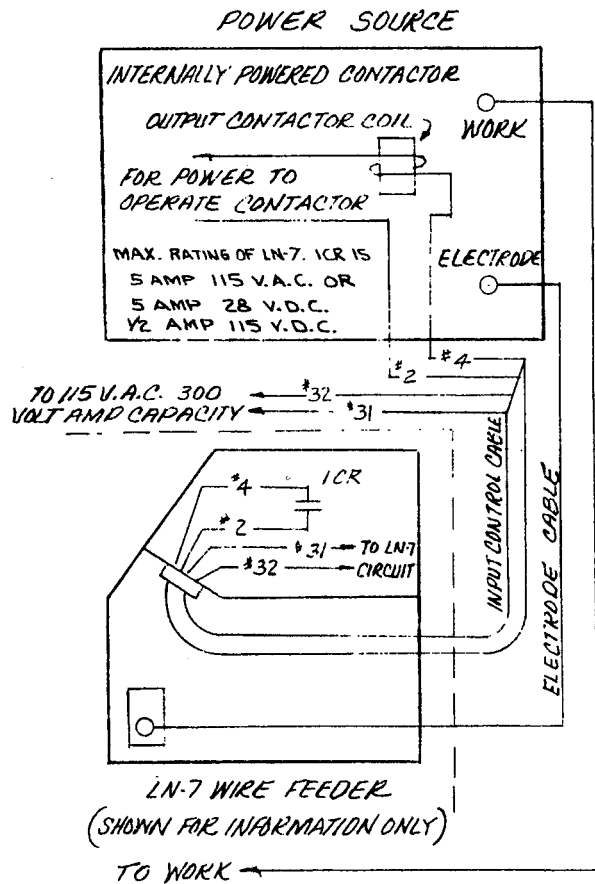

January 1976

## SEC. J2.5 OPTIONAL FEATURES INSTALLATION

### Sec. J2.5.3

#### K-178 Mounting Platform – LN-7 on Idealarc R3S

This is a turntable type platform for mounting the LN-7 on the top of Idealarc R3S power sources. Bolt the platform to the lift bail per instructions supplied with the platform.

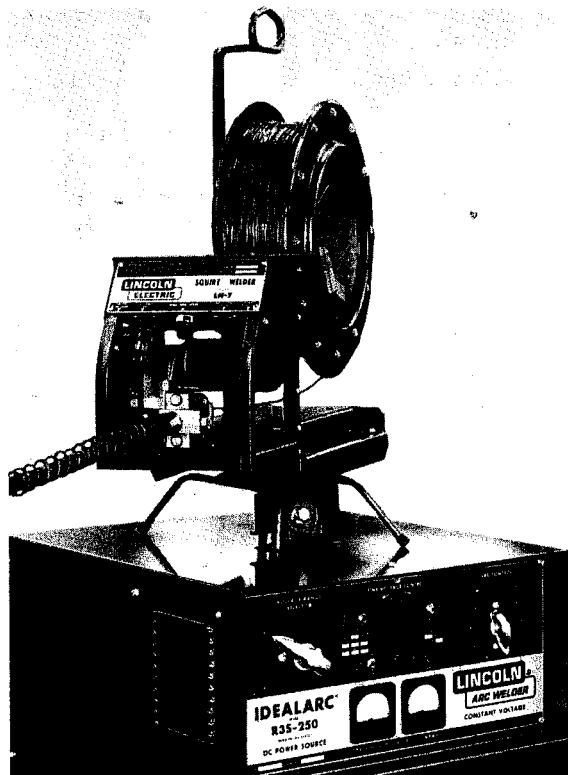

September 1971

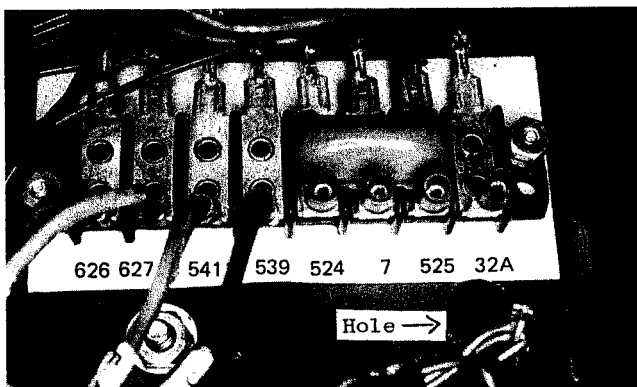

### Sec. J2.5.5

#### Auxiliary Equipment Contacts

The Power for 115 volt AC auxiliary equipment can be obtained from the terminal strip inside the control box. The contacts are "hot" only when the gun trigger is operated. The current draw of this circuit must not exceed 1/4 ampere.

Route the leads thru the hole in the bottom of the control box to the terminal strip. Spare quick connect terminals are provided on the terminal strip. Remove these terminals and crimp them to the lead wires. Connect the leads to numbers 32A and 7 on the terminal strip. Install a suitable cable clamp on the leads to prevent excess tension on the terminals and protect the lead insulation at the edge of the hole.

March 1973

### Sec. J2.5.7

#### K-162 Spindle For Mounting 10 thru 30 Pound Spools

To mount the spindle kit for 10 thru 30 pound spools, remove the shaft for the standard 50-60 pound wire coils from the mounting framework. Install the spindle per the instructions shipped with the kit.

Adjust the brake tension screw (see Sec. J3.1.6) on the spindle as needed.

September 1971

### Sec. J2.5.8

#### K-163 Undercarriage

The undercarriage includes the wheels, handle and hardware. Mount the casters at the front and the wheels to the rear of the platform. Be sure the round, rear axle is to the rear of the mounting bolts that hold the U-shaped axle member to the frame. Bolt the handle to the front of the platform so the LN-7 can be tilted back and wheeled like a two-wheel truck. Holes for installing the wire reel support are provided in the platform.



September 1971

## SEC. J3 OPERATING INSTRUCTIONS

### Sec. J3.1.1

#### Adjusting Current and the Voltage

Use only constant voltage type power sources. If using a multiple process power source, be sure it is set for constant voltage output per instructions in the manual for the power source.

Set the voltage using the controls on the power source.

For the most accurate *arc* voltage readings, connect the meter leads between the work and the brass gun cable connection block of the LN-7 and read the voltmeter while welding. Approximate welding voltages can be obtained by reading the power source voltmeter while welding.

On constant wire feed speed type wire feeders like the LN-7, welding current is controlled by the wire feed speed. With the 'Wire Feed Speed' control set on Min. the wire feeds at a little under 50" per minute and the welding current is low. When set on Max., the electrode feeds at more than 500" per minute and the welding current is high.

If the power source is equipped with meters, the welding current can be read directly on the ammeter while welding.

If the power source has no meters and the relationship between current and wire feed speed is known, current can be accurately set by measuring the wire feed speed. To measure wire feed speed disconnect the electrode cable at the power source:

1. Press the gun trigger and feed electrode for 15 seconds.
2. Measure the wire feed in inches and multiply by 4. This gives the wire feed speed in inches/minute.
3. Adjust the 'Wire Feed Speed' control until the desired speed is obtained.

January 1976

### Sec. J3.1.2

#### Arc Starting

The LN-7 starts at a slow wire feed speed and low current and automatically accelerates quickly to the welding speed set by the 'Wire Feed Speed' control. The electrode should be **lightly** touching the work when the gun trigger is pressed. This low starting current improves the starting characteristics and minimizes skipping, stubbing, and spatter when striking the arc with both normal and Linc-Fill long stickout welding procedures. This standard feature requires no adjustment.

September 1976

### Sec. J3.1.3

#### Circuit Protection

The AC input line is protected by both a circuit breaker and a fuse.

The circuit breaker protects the LN-7 from moderate overloads, usually caused by excessive wire drag or other wire feeding problems. To reset the circuit breaker, push the red button on the underside of the control box. If it opens again, determine the cause of the overload.

The fuse protects the LN-7 from sudden high current overloads such as a shorted motor or other short circuit conditions. Determine and correct the cause of overloading. Replace the fuse with one of the same size and type.

November 1972

### Sec. J3.1.4

#### Adjustable Wire Reel Brake

The mount for standard 50 and 60 pound electrode coils includes a two position brake assembly. Generally the brake should be at the inner position (nearest to the wire reel shaft) for wire feed speeds below 400"/min. It should be at the outer position for the faster wire speeds often used when feeding small diameter electrode.

To adjust the brake position, remove the wire reel. Pull the cotter pin that holds the brake shoe to the arm, move the shoe and replace the cotter pin. Do not bend the cotter pin — it is held in place by a friction fit.

Machines built before November 1972 do not have an adjustable brake.

See Sec. J3.1.6 for adjustment instructions for the brake on the spindle for 10-25 pound spools.

November 1972

### Sec. J3.1.5

#### Wire Reel Loading — 50 and 60 Pound Coils

1. To remove the wire reel from its shaft, grasp the spring loaded knob and pull it out. This straightens the knob so it seats into the shaft when released. Remove the reel.
2. Lay the reel flat on the floor, loosen the spinner nut and remove the cover plate.
3. Before cutting the tie wires place the coil of electrode on the reel so it unwinds as the reel rotates clockwise.
  - A. Be sure the coil is placed so the spring loaded arms will not interfere with the later removal of the coil tie wires. (See photo.)
  - B. When loading .035 and .045" electrode, be certain the coil is placed on the reel so the spring loaded arms

are at the center of the slots in the cardboard coil liner. This provides the positive compression of the coil needed for trouble free wire feeding. (See photo).

- C. Put the cover plate on the reel so the four arms of the cover straddle and are in line with the spring loaded arm of the reel proper.

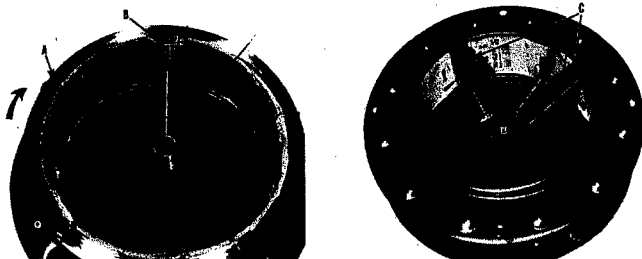

- 4. Tighten the cover as much as possible by hand. DO NOT hammer on the spinner nut arms.
- 5. Cut and remove **only** the tie wire holding the free end of the coil. Insert the free end into one of the holes in the cover and secure it by bending it back. Cut and remove the remaining tie wires.

**NOTE:** Always be sure the free end of the coil is securely held while the tie wires are being cut and until the wire is feeding through the drive rolls. Failure to do this will result in "back lashing" of the coil, which may tangle the wire. A tangled coil will not feed so it must either be untangled or discarded.

- 6. Replace the reel on the wire feeder. Grasp the shaft knob, pull it out and swing it across the reel hub.
- 7. Turn the reel until the free end of the electrode is accessible. While tightly holding the electrode, cut off the bent end. Straighten the first six inches and insert it through the wire guide to the drive rolls. Press the gun trigger until the rolls pick up the wire and feed it through the gun cable.

**WARNING:** When inching, the electrode is always "hot" to ground.

September 1971

Sec. J3.1.6

**Wire Reel Loading – 10 to 30 Pound Spools**

Remove the locking knob from the shaft. Place the 25 lb. spool on the shaft making certain the brake driving

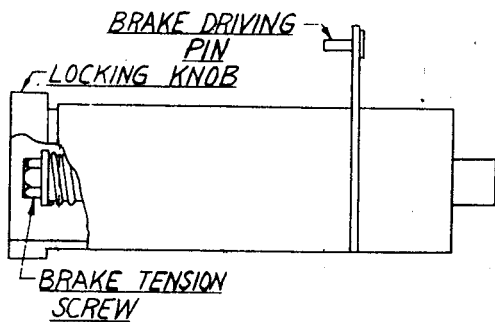

pin enters one of the holes in the back side of the spool. Replace and tighten the locking knob. Be certain the wire comes off the reel in a clockwise direction. The spool should turn freely without any overrun. Adjust the brake tension with the hex head screw on the shaft hub, until the reel turns freely but with little or no overrun.

Sec. J3.1.7

**Sequence of Welding**

See page 2 for general arc welding safety precautions.

1. Install the LN-7 per Sec. J2.
2. Load the wire reel per Sec. J3.1.5 or J3.1.6.
3. Ground the work.
4. Set the power source polarity switch or properly connect the electrode and ground lead for the correct electrode polarity.
5. Set the voltage using the power source controls per Sec. J3.1.1.
6. Set the current per Sec. J3.1.1.
7. Press the gun trigger to inch the wire until it sticks about 3/4" beyond the end of the gun. Position the gun so the electrode is **lightly** touching the work. Avoid pushing the electrode against the work before starting to weld. Press the gun trigger to start welding. Current can be adjusted while welding using the 'Wire Feed Speed' control on the LN-7.
8. To stop welding, release the gun trigger and lift the gun from the work. The wire feed motor stops and the welding circuit is de-energized the moment the trigger is released. If an auxiliary device is connected to #7 and #32 in the LN-7 control box, (See Sec. J2.5.5), this device is de-energized when the trigger is released.

May 1975

Sec. J3.1.9

**Wire Reel Changing**

At the end of a coil remove the last of the old electrode coil from the conductor cable with the following procedures:

1. Cut the end of the electrode off at the gun end. Do not break it off by hand because this puts a slight bend in the wire making it difficult to pull it back through the nozzle.
2. Uncouple the gun conductor cable from the connection block on the LN-7 drive unit.
3. Lay the gun and cable out straight.
4. Using pliers to grip the wire, pull it out of the cable from the connector end. Do not pull it from the gun end.
5. After the electrode has been removed, connect the gun conductor cable back to the LN-7.

Load a new reel of electrode per the instructions in Sec. J3.1.5 or J3.1.6.

September 1971

## SEC. J6.1 WIRE FEEDER MAINTENANCE

**WARNING:** Have a qualified electrician do the maintenance and trouble shooting work.  
Turn the input power off at the power source before working inside the wire feeder.

### Sec. J6.1.1

#### Wire Drive Motor and Gear Box

Every year inspect the gear box and paint the gear teeth with graphite grease.

Every six months check the motor brushes. Replace them if they are less than 1/4" long.

September 1971

### Sec. J6.1.2

#### Drive Rolls and Guide Tubes

Periodically inspect the drive roll section. Clean it as necessary. Do not use solvents for cleaning the idle roll because it may wash the lubricant out of the bearing. The drive roll, idle roll and guide tubes are stamped with the wire sizes they will feed. If a wire size other than that stamped on the rolls is to be used, the rolls and guide tubes should be changed.

The drive roll for 1/16, .068, 5/64, 3/32 and 7/64" electrode have a double set of teeth so they can be reversed for additional life. Between the two knurled rolls (except

1/16" rolls) is a shim washer which limits the damage to the electrode if wire feeding problems occur. See Sec. J2.2.2 for roll changing instructions.

Drive rolls for .045 and .035 electrodes have no teeth. They are not reversible.

September 1971

### Sec. J6.1.3

#### Wire Reel Mounting – 50 and 60 Pound Coils

To prolong the life of the reel shaft, periodically coat it with a thin layer of grease.

No maintenance of the two position adjustable brake installed on machines built after November 1972 is needed except to replace the shoe assembly if it wears through.

November 1972

### Sec. J6.1.5

#### Control Box

The control box requires no routine maintenance.

September 1971

## SEC. J6.2 GUN AND CABLE MAINTENANCE

### Sec. J6.2.1

#### Gun Cable

A dirty gun cable can cause rough and erratic wire feeding. Therefore, the cable liner must be cleaned periodically.

Remove the cable from the wire feeder. Lay it out straight on the floor. Remove the contact nozzle tip from the gun. Using an air hose and only partial pressure, gently blow out the cable. Work the full length of the cable by bending it back and forth then blow it out again. Continue this procedure until cable is clean.

October 1981

### Sec. J6.2.2

#### Gun Disassembly: K-115 and K-126 Innershield Squirtguns

To remove the nozzle from the gun, loosen the 3/16" Allen head screw in the gun handle and pull the nozzle straight out. To reinstall, insert the nozzle into the gun handle. Push it in as far as possible and tighten the Allen head screw.

To disassemble Innershield Squirtguns K-115 and K-126, first loosen the screws which hold the heat shield in place. Remove the heat shield.

To disassemble the switch housing from all these guns, remove the four screws holding the saddle around the gun handle. Then hold the housing with the cable toward the floor and look into the switch cavity. The tight side of the larger roll pins is to the right. Drive these pins to the left. They can be easily removed when they clear the right side of the casting. Do not remove the smaller roll pins unless the trigger is being replaced. The height of the Z spring controls the operating point of the switch with respect to the trigger movement. Set the spring so the switch operates at about the mid-point of the trigger travel.

To remove the handle from the cable, slip the spatter shield out of the front of the handle. Remove the 1/4-20 socket head screw through the hole in the side of the handle. Then pull the handle back on the cable. Remove the snap ring and connector clamp and the handle can then be slipped off the cable.

September 1971

## SEC. J6.4 LN-7 SEQUENCE OF OPERATION

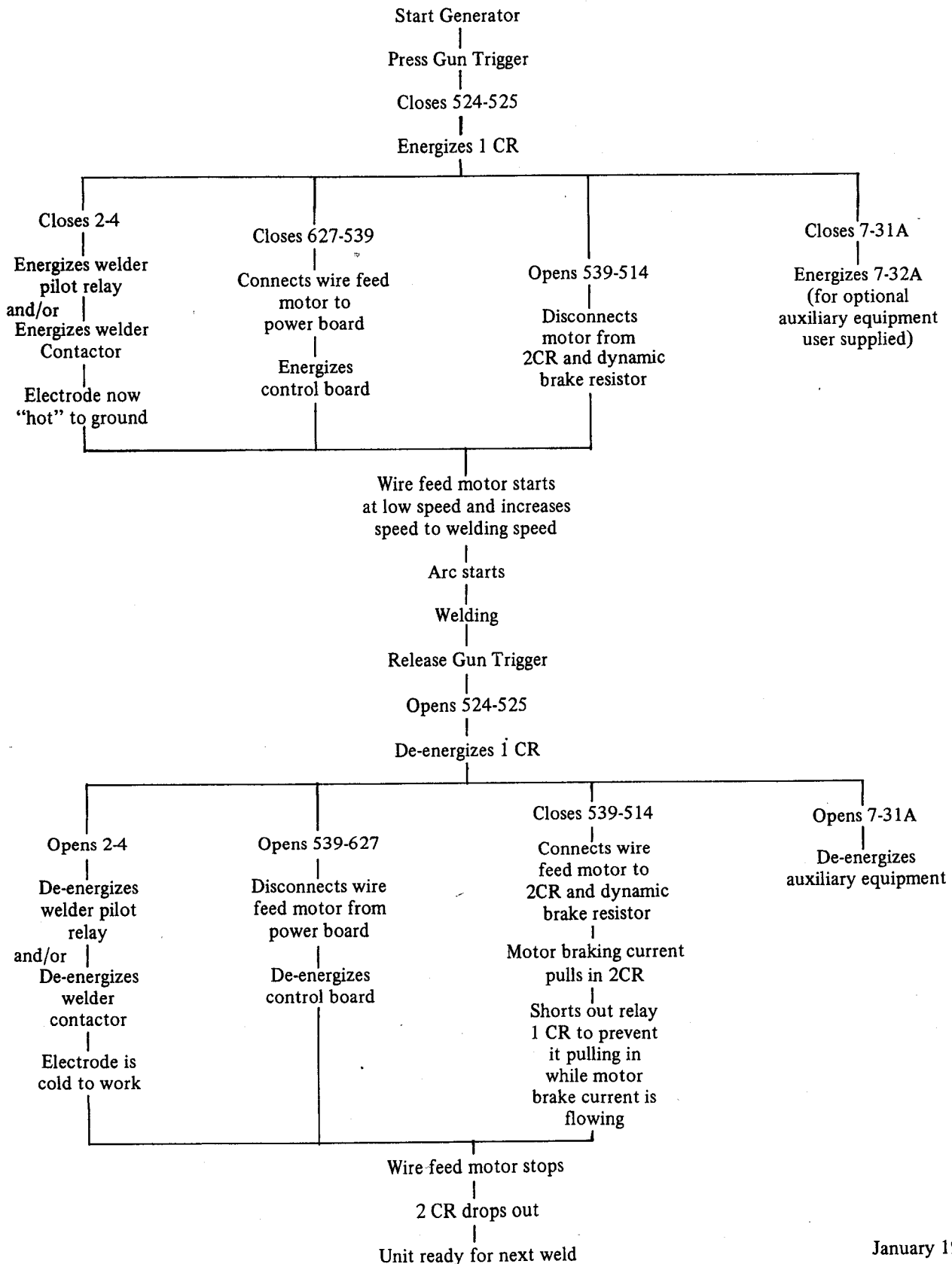

January 1972

## SEC. J6.6 TROUBLESHOOTING

**WARNING:** Have a qualified electrician do the maintenance and trouble shooting work. Turn the input power off using the disconnect switch at the fuse box before working inside the machine.

Trouble	Cause	What to Do
1. Rough wire feeding or wire not feeding but drive rolls turning.	<ul style="list-style-type: none"> <li>a. Gun cable kinked and/or twisted.</li> <li>b. Wire jammed in gun and cable.</li> <li>c. Incorrect drive rolls and guide tubes.</li> <li>d. Drive rolls loose.</li> <li>e. Gun cable dirty.</li> <li>f. Worn drive rolls.</li> <li>g. Electrode rusty and/or dirty.</li> <li>h. Worn nozzle liner.</li> <li>j. Partially flashed or melted contact tip.</li> </ul>	<ul style="list-style-type: none"> <li>a. Inspect gun cable and replace if necessary.</li> <li>b. Remove wire from gun and cable — feed in new wire. Note any obstructions in gun and cable. Replace gun and cable if necessary.</li> <li>c. Check wire diameters stamped on drive rolls, wire guides, and drive roll spacers for correct combination for wire being used.</li> <li>d. Remove, clean, install and tighten.</li> <li>e. Clean per Sec. J6.2.1.</li> <li>f. Replace and/or reverse split drive roll type.</li> <li>g. Replace.</li> <li>h. Replace.</li> <li>j. Replace contact tip.</li> </ul>
2. Variable or "hunting" arc.	<ul style="list-style-type: none"> <li>a. Worn and/or melted contact tip.</li> <li>b. Worn or undersize work cable or poor work connection.</li> <li>c. Loose electrode connections.</li> </ul>	<ul style="list-style-type: none"> <li>a. Replace tip — remove any spatter on end of tip.</li> <li>b. Inspect — repair or replace as necessary.</li> <li>c. Be sure electrode lead is tight. Gun cable tight in wire feeder contact block. Gun nozzle and gun tip tight.</li> </ul>
3. Weld Porosity, narrow and ropey bead, or electrode stubbing into plate when welding.	<ul style="list-style-type: none"> <li>a. Dirty plate or improper procedures.</li> </ul>	<ul style="list-style-type: none"> <li>a. See trouble shooting information in Bulletin N676, "Innershield Semiautomatic Welding Guide."</li> </ul>
4. LN-7 circuit breaker trips while welding.	<ul style="list-style-type: none"> <li>a. See Trouble 1 above.</li> <li>b. High ambient temperature (causing circuit breaker to trip.)</li> <li>c. Electrical problems in power source or LN-7.</li> </ul>	<ul style="list-style-type: none"> <li>a. Correct problems.</li> <li>b. Provide better ventilation for LN-7.</li> <li>c. See Trouble 5.</li> </ul>
5. LN-7 or power source electrical problems such as: LN-7 fuse blows. Power Source Fuse blows. LN-7 circuit breaker trips. No control of wire feed motor. Wire feed motor won't run. Auxilliary equipment connected to 32A and 7 won't work. Power source contactor won't work, but LN-7 feeds wire.	<ul style="list-style-type: none"> <li>a. Loose connection or broken lead.</li> <li>b. Electrical component has failed.</li> </ul>	<ul style="list-style-type: none"> <li>a. Turn power source and LN-7 <b>off</b> and check leads and connections.</li> <li>b. Replace blown fuses or reset circuit breaker and try to weld. If trouble recurs, call Lincoln semiautomatic distributor, local representative or authorized Field Service Shop.</li> </ul>

October 1971

### LN-7 WIRE FEEDER

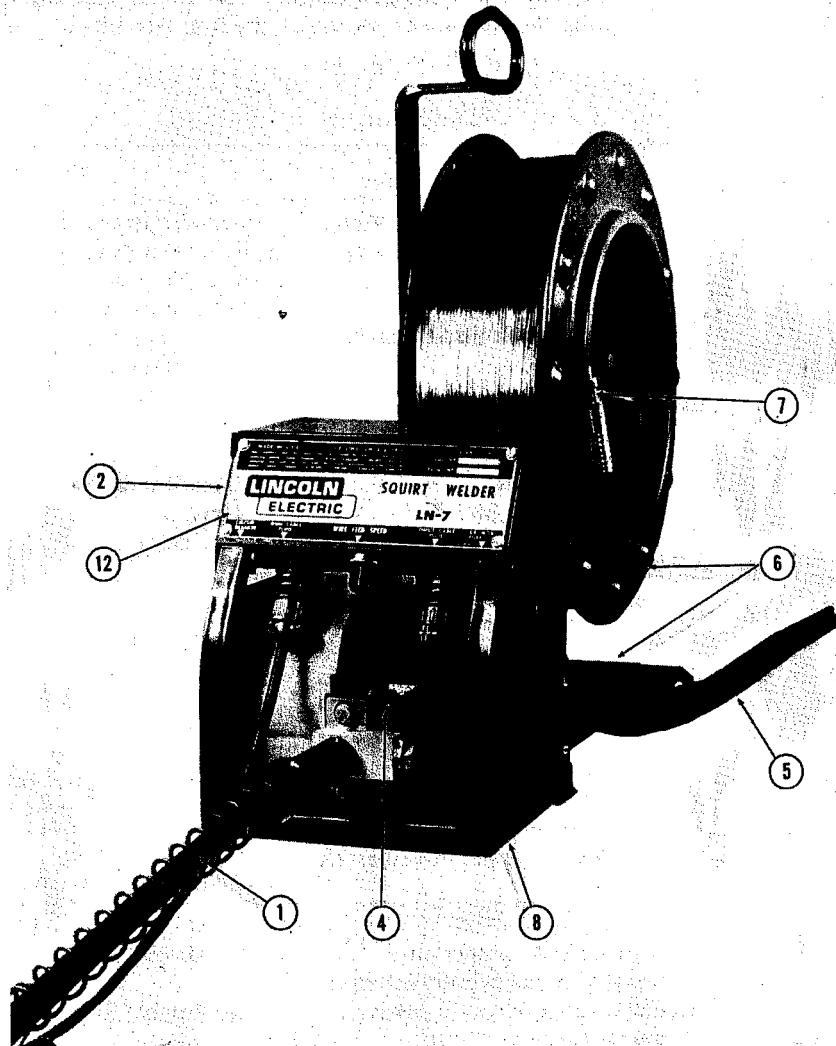

Parts List P-109-C		
ITEM	PART NAME AND DESCRIPTION	NO. REQ'D.
1	Gun and Cable Assembly	See Sec. J7.3
2	Control Box	See 109-D
	Self Tapping Screw (Control Box & Cover to Frame)	6
4	Wire Drive Mechanism	See 109-F
5	Input Cable and Extension Cable Assembly	See 109-H
6	Wire Reel Support (50# and 60#)	See 107-0
7	Wire Reel Shaft	See 107-P
8	Drive Unit Frame Assembly	1
12	Nameplate	1
	Self Tapping Screw to Mount Nameplate	4

# CONTROL BOX

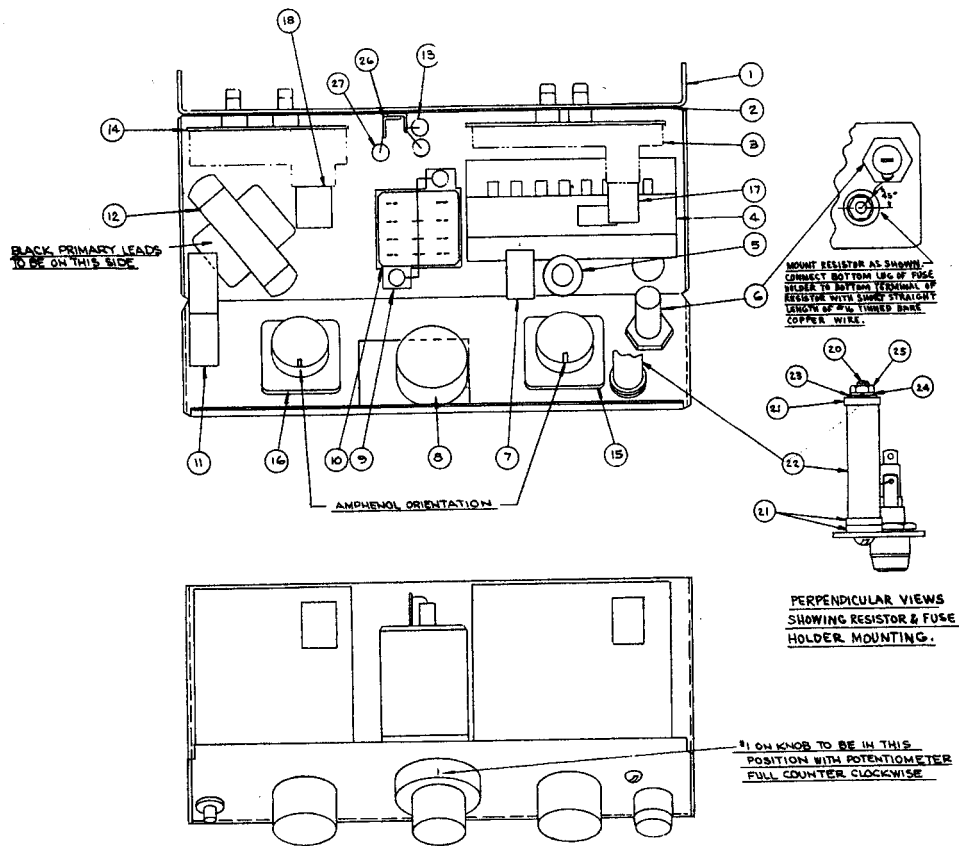

Parts List P-109-D			
ITEM	PART NAME AND DESCRIPTION	NO. REQ'D.	NO. REQ'D.
	Complete Control Box, Includes:		
1	Case	1	
2	P.C. Board Insulation	1	
3	Control Circuit P.C. Board	1	
	Self Tapping Screw	2	
	Plastic Expansion Nut	2	
4	Terminal Strip Assembly	1	
	Number Plate	1	
	Round Head Screw	2	
	Lockwasher	2	
	Hex Nut	2	
5	Grommet	1	
6	Fuse Holder	1	
	Fuse, 5 Amp	1	
7	Lead Clamp	1	
	Sems Screw	1	
	Flatwasher	1	
8	Hex Nut	1	
	Potentiometer	1	
	Insulation	1	
9	Knob	1	
	Relay Socket	1	
	Spring	1	
	Spacer Tube	2	
	Round Head Screw	2	
	Flatwasher	2	
	Lockwasher	2	
	Hex Nut	2	
10	A.C. Relay	1	
11	Circuit Breaker	1	
12	Transformer	1	
	Round Head Screw	2	
	Lockwasher	2	
	Hex Nut	2	
13	Reed Switch Assembly	1	
	Terminal Strip (Small)	1	
	Resistor (1/2 Watt)	1	
	Resistor (2 Watts)	1	
	Reed Switch Coil	1	
	Reed Switch	1	
	Route Head Screw	2	
	Lockwasher	2	
	Hex Nut	2	
14 <sub>a</sub>	Power Circuit P.C. Board	1	
	Self Tapping Screw	2	
	Plastic Expansion Nut	2	
15	Input Polarized Plug	1	
	Self Tapping Screw	4	
16	Output Polarized Plug	1	
	Self Tapping Screw	4	
17	P.C. Board Receptacle	1	
18	P.C. Board Receptacle	1	
20	Round Head Screw	1	
21	Insulating Washer	3	
22	Resistor	1	
23	Flat Washer	1	
24	Lockwasher	1	
25	Hex Nut	1	
26	Terminal Strip	1	
27	Resistor	1	
	Parts Not Illustrated		
	Control Box Cover		1
	Choke, Mounted to Cover		1

## WIRE DRIVE MECHANISM

**NOTE A:** When ordering these parts, always specify wire size.  
Some of these parts can be used for more than one wire size. All suitable sizes are stenciled on each part.  
Complete kits containing items 2, 7, 20, 22 and 25 are available for wire sizes .035, .045, .052, 1/16, .068, 5/64, 3/32 and 7/64" wire diameters. Order "LN-7 Wire Size Conversion Kit For (specify wire size) Wire."

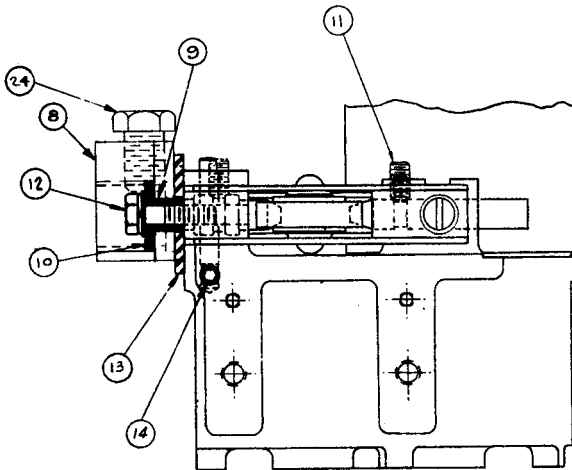
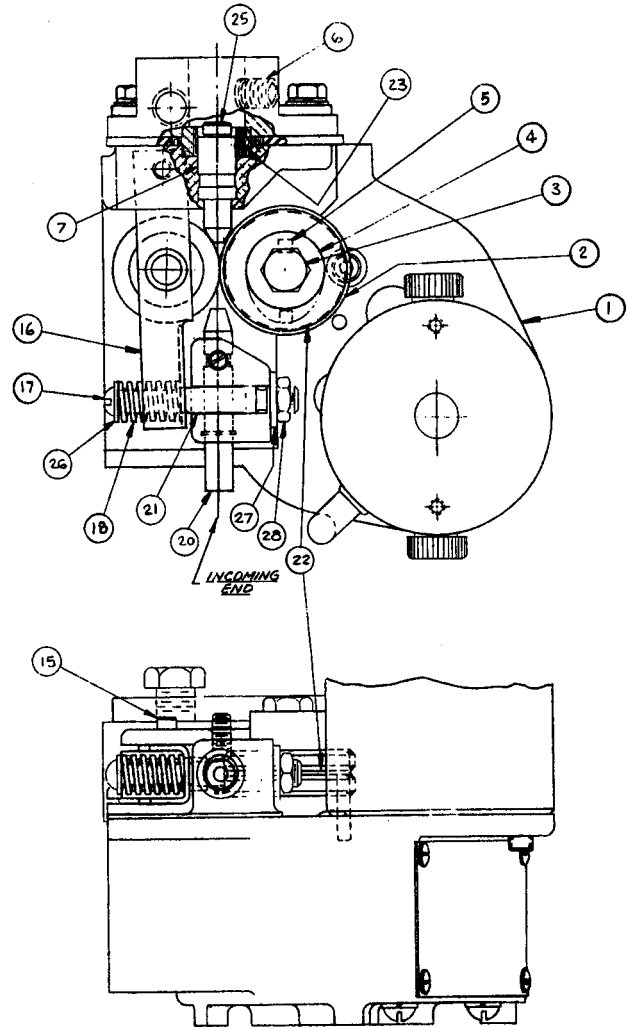

Parts List P-109-F

ITEM	PART NAME AND DESCRIPTION	NO. REQ'D.	ITEM	PART NAME AND DESCRIPTION	NO. REQ'D.
1	Drive Motor and Gear Box, includes:	1	13	Conductor Block Insulation	1
	Drive Motor	1	14	Socket Set Screw	1
	Drive Motor, includes	1	15	Pivot Pin	1
	Pinion Gear	1	16	Idle Roll Assembly	1
	Roll Pin	1	17	Round Head Screw	1
	Gear Box	1	18	Spring	1
2*	Drive Roll - Specify Wire Size	1	19	Retaining Ring	1
	(Order 1 roll for .035 and .045		20*	Incoming Guide Tube - Specify Wire Size	1
	Order 2 rolls for 1/16 - 7/64)		21	Idle Roll Pull Arm	1
3	Hex Head Screw	1	22*	Spacer - Specify Wire Size - For .068 - 7/64" Wire	1
4	Collar Assembly	1	23	Locator Bushing	1
5	Key	1	24	Hex Head Screw	1
6	Socket Set Screw	1	25*	Outgoing Guide Tube Insert - Specify Wire Size	1
7*	Outgoing Guide Tube - Specify Wire Size	1	26	Flatwasher	1
8	Conductor Block Assembly	1	27	Flatwasher	1
9	Insulating Bushing	2	28	Hex Nut	1
10	Insulating Washer	2			
11	Slotted Headless Set Screw	2	*	See NOTE A Above	
	Hex Head Screw	2			
12	Lockwasher	2			

November 1972

### K-115 SQUIRTGUN AND CABLE

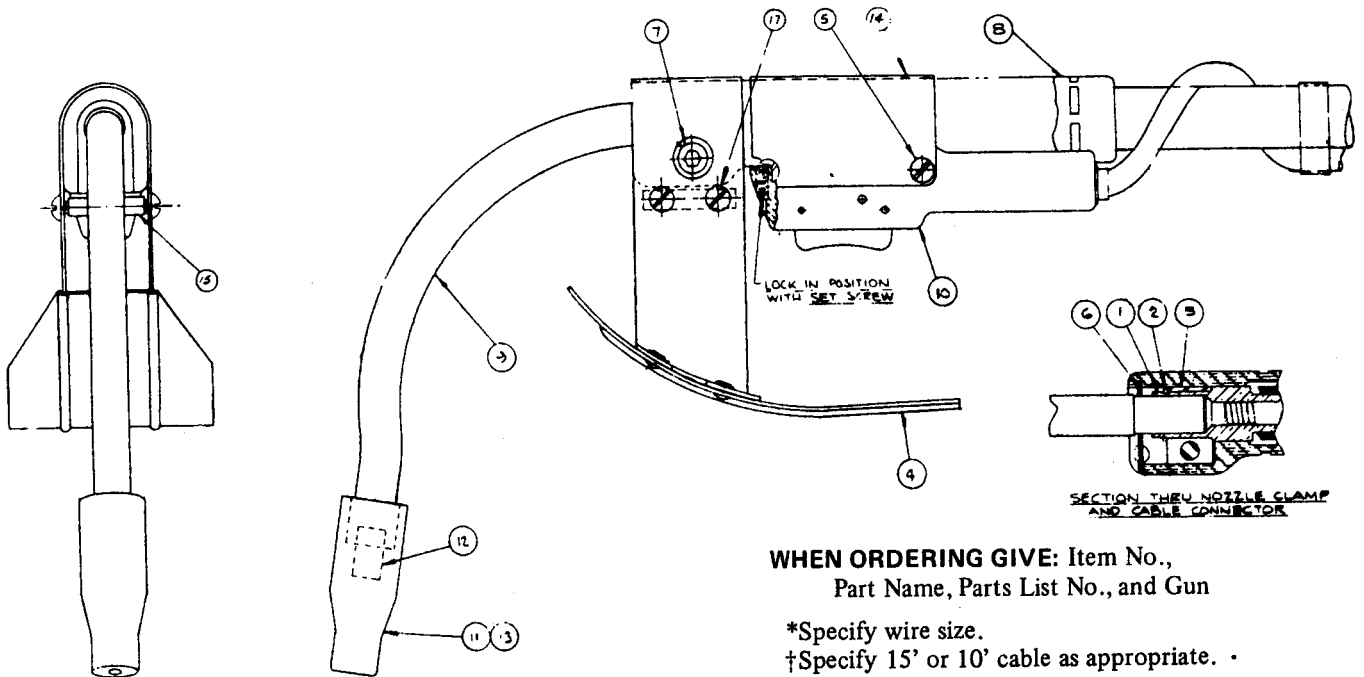

WHEN ORDERING GIVE: Item No.,  
Part Name, Parts List No., and Gun

\*Specify wire size.  
†Specify 15' or 10' cable as appropriate.

Parts List P-103-F

ITEM	PART NAME AND DESCRIPTION	NO. REQ'D.
† *	Gun and Cable Assembly	1
.1 †	Conductor Cable, Includes:	1
1A	Handle and Stiffener, Wire Feeder End	1
1B	Connector, Wire Feeder End	1
1C	Connector, Gun End	1
2	Snap Ring	1
3	Clamp	1
4	Heat Shield Assembly	1
5	Pan Head Screw	4
6	Spatter Shield	1
7	Socket Head Screw	1
8	Handle	1
9*	Nozzle (82°) Includes:	1
9*	Nozzle (45°) Includes:	1
9A*	Nozzle Liner, Tight Wound Steel Spring	1
9B*	Nozzle Insert	1
9C	Nozzle Insert Retainer	1
9D	Liner Locking Screw	1
10†	Trigger and Control Cable Assembly	1
	Assembly Parts See P-103-K	
11	Insulated Guide, 2-3/4" Electrical Stickout	1
11	Insulated Guide, 3-3/4" Electrical Stickout	1
11	Insulated Guide, 1-1/4" Electrical Stickout	1
12*	Contact Tip, .120 Electrode	As Req'd.
12*	Contact Tip, 7/64 Electrode	As Req'd.
12*	Contact Tip, 3/32 Electrode	As Req'd.
14	Switch Housing Clamp	1
15	Shield Mounting Block	1
17	Round Head Screw	4

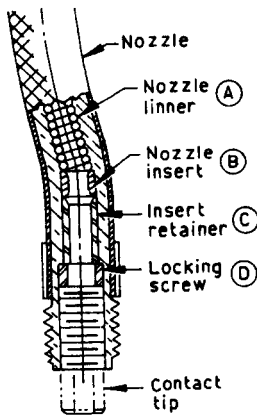

August 1974

### K-126 SQUIRTGUN AND CABLE

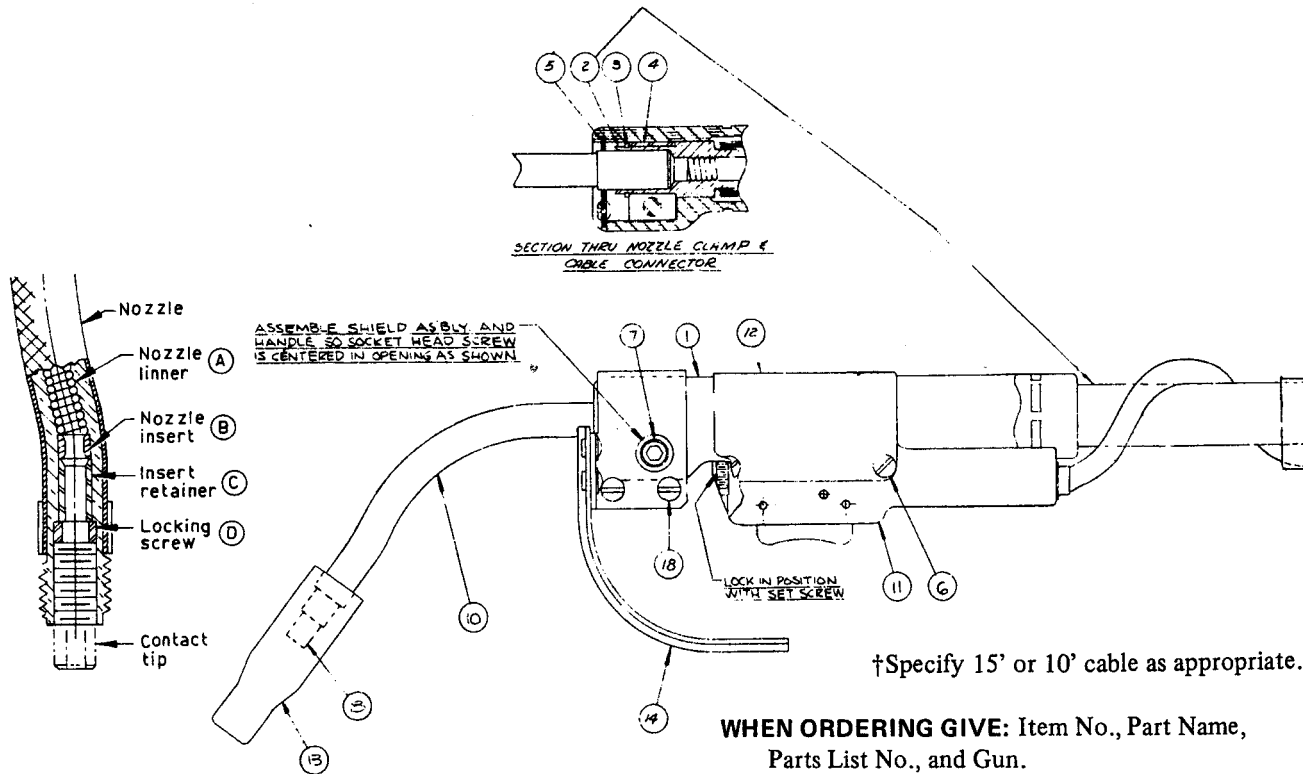

WHEN ORDERING GIVE: Item No., Part Name, Parts List No., and Gun.

K-126 - Parts List P-103-J		
ITEM	PART NAME AND DESCRIPTION	NO. REQ'D.
†	Gun and Cable Assembly	1
1	Handle	1
2	† Conductor Cable, Includes:	1
2A	Handle and Stiffener, Wire Feeder End	1
2B	Connector, Wire Feeder End	1
2C	Connector, Gun End	1
2D	Clamping Tube, Both Ends	2
3	Snap Ring	1
4	Clamp	1
5	Splatter Shield	1
6	Pan Head Screw	4
7	Socket Head Cap Screw	1
8	Contact Tip, 5/64" Electrode	As Req'd
8	Contact Tip, 3/32" Electrode	As Req'd
8	Contact Tip, .068" Electrode	As Req'd
10	Nozzle Assembly, Includes	1
10A	Nozzle Liner, Tight Wound Steel Spring	1
10B	Nozzle Insert	1
10C	Nozzle Insert Retainer	1
10D	Liner Locking Screw	1
11	† Trigger and Control Cable Assembly	See P-103-K
12	Clamp	1
13	Insulated Guide, 2-3/4" Electrical Stickout	1
13	Thread Protector, 3/4 to 1-1/2" Stickout	1
14	Hear Shield Assembly	1
18	Round Head Screw	4

August 1974

### TRIGGER AND CONTROL CABLE ASSEMBLY

Cable Assembly - Parts List P-103-K		
ITEM	PART NAME AND DESCRIPTION	NO. REQ'D.
†	Trigger and Control Cable Assembly, Includes:	1
1	Micro-Switch	1
2	Switch Pad	1
3	Trigger Assembly	1
4	Cord Clamp	1
5	Coil Spring	2
6	Roll Pin	2
7	Roll Pin	2
8	Insulating Sleeving	1
9	Set Screw	1
10	Cord Clamp	1
12	Polarized Plug, Wire Feeder End, Not Illus.	1
12A	Clamp at Polarized Plug	1

August 1974

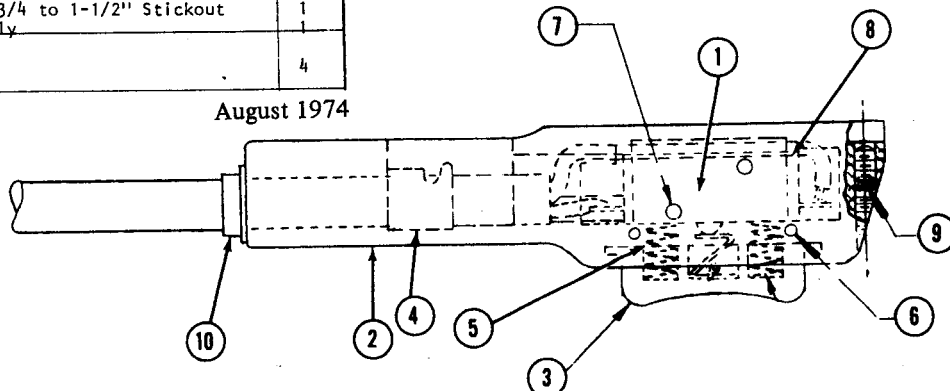

### 50 AND 60 # WIRE REEL SUPPORT

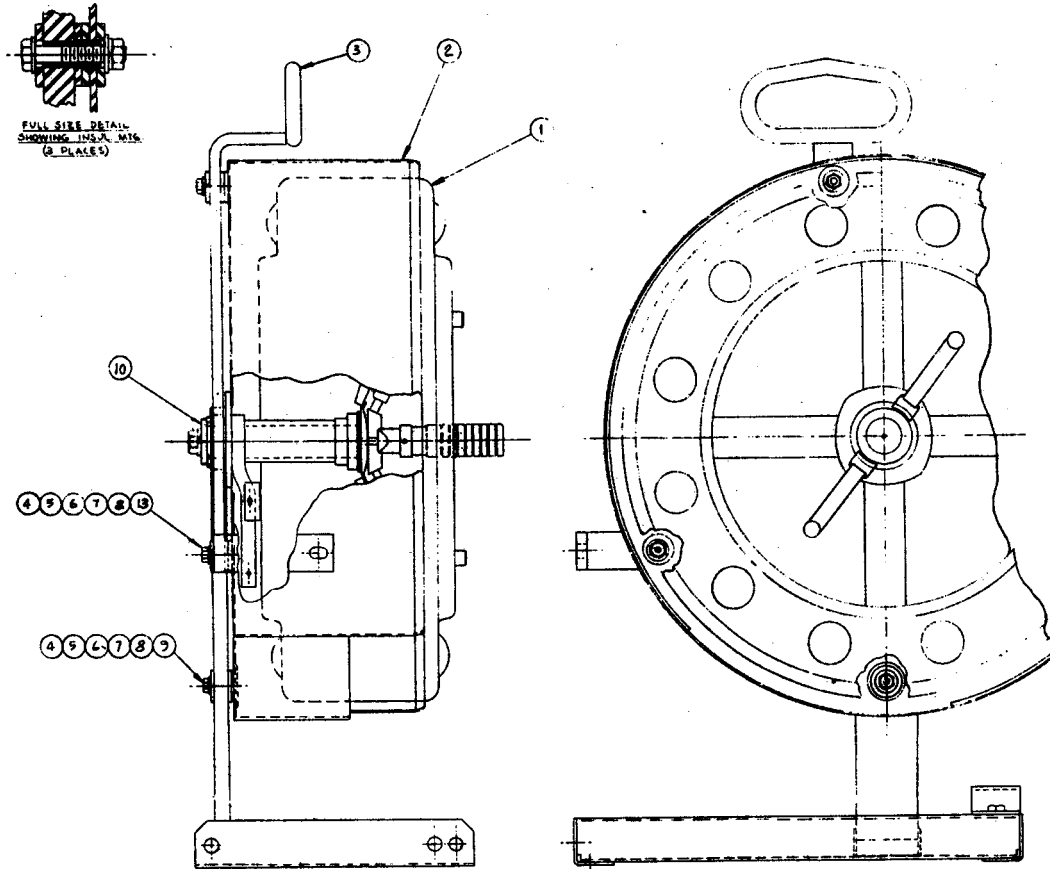

Parts List P-107-O		
ITEM	PART NAME AND DESCRIPTION	NO. REQ'D.
	Wire Reel Support Assembly, includes:	1
1	Wire Reel	1
3	Reel Support	1
10	Reel Mounting Shaft Assembly	P-107-P
	Optional Wire Reel Cover Parts Kit, includes:	1
2	Wire Reel Housing	1
4	Flatwasher	6
5	Lockwasher	3
6	Hex Nut	3
7	Hex Head Screw	3
8	Insulating Washer	12
9	Insulating Tube	1
13	Insulating Tube	2
	Optional Door Parts Kit, includes: (Wire Reel Cover Must Be Installed.)	1
	Door and Hinge Welded Assembly	1
	Catch	1
	Sems Screw (Catch Mounting)	2
	Sealing Panel	1

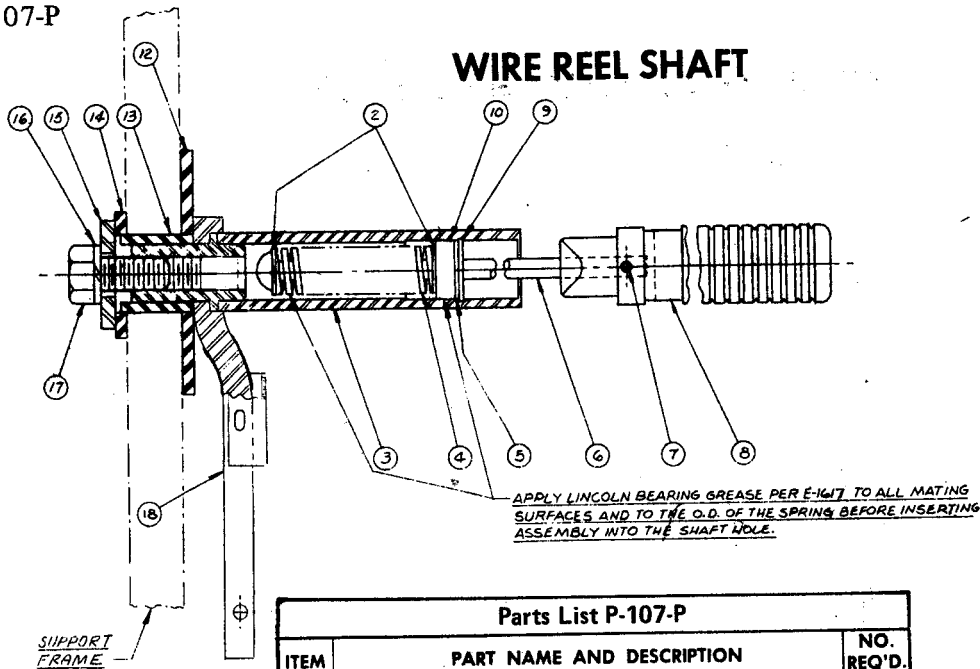

Parts List P-107-P		
ITEM	PART NAME AND DESCRIPTION	NO. REQ'D.
	Reel Mounting Shaft Assembly, Includes:	1
2	Flat Spring Steel Washer	2
3*	Reel Mounting Shaft	1
4	Spring	1
5	Flat Spring Steel Washer	1
6	Rivet	1
7	Roll Pin	1
8	Pull Knob	1
9	Snap Ring	1
10	Bronze Washer	1
12	Insulating Washer	1
13	Insulating Tube	1
14	Insulating Washer	1
15	Flatwasher	1
16	Lockwasher	1
17	Hex Head Screw	1
18	Brake Assembly	1
*	LN-7 welders built before November 1972 did not have the adjustable brake (item 18). If a shaft or fixed brake assembly is needed, order the complete shaft assembly.	

January 1973

## INPUT CABLE AND EXTENSION CABLE ASSEMBLIES

Parts List P-109-H		
ITEM	PART NAME AND DESCRIPTION	NO. REQ'D.
	Power Input Cable Assembly, includes:	1
	Control Cable Assembly, includes:	1
	Polarized Connector (Female)	1
	Clamp	1
	Electrode Cable Assembly	1
	* When ordering, always specify length required	
	Extension Cable Assembly, includes:	1
	Control Cable Assembly	1
	Polarized Connector (Female)	1
	Polarized Connector (Male)	1
	Clamp	2
	Electrode Cable Assembly	1

August 1971

# OPERATING SCHEMATIC

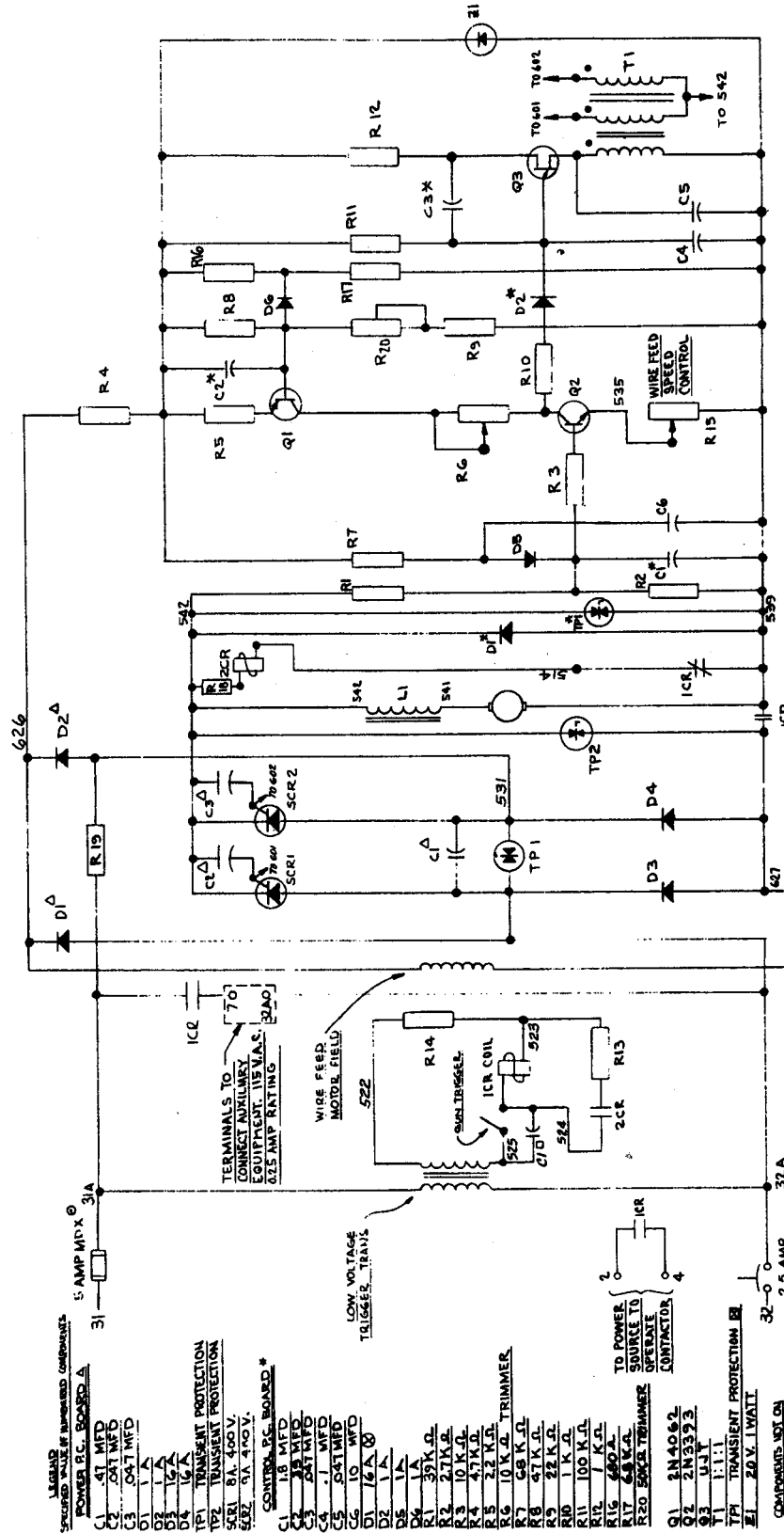

NOTE: Q1 MAY BE REPLACED WITH A 5 AMP 125 V. OR 250 V SLO-BLO FUSE.  
 SINCE COMPONENTS OR CIRCUITRY ON A PRINTED CIRCUIT BOARD MAY CHANGE WITHOUT AFFECTING THE INTERCHANGEABILITY OF A COMPLETE BOARD, THIS DIAGRAM MAY NOT SHOW THE EXACT COMPONENTS OR CIRCUITRY OF CONTROLS HAVING A COMMON CODE NUMBER.

ONLY APPEARS ON MACHINES MANUFACTURED AFTER JUNE 1972.  
 -3A ON MACHINES MANUFACTURED BEFORE NOVEMBER 1972.  
 A.N.S.I. ELECTRICAL SYMBOLS

ICR MAIN RELAY  
 2CR REED SWITCH RELAY  
 (OPERATED BY DYNAMIC BRAKE CURRENT)

# LN-7 CONNECTION SCHEMATIC

For older machines built to Code 7024 only, request diagram M-12354.  
(Use M-12381 for Code 7024 A.)

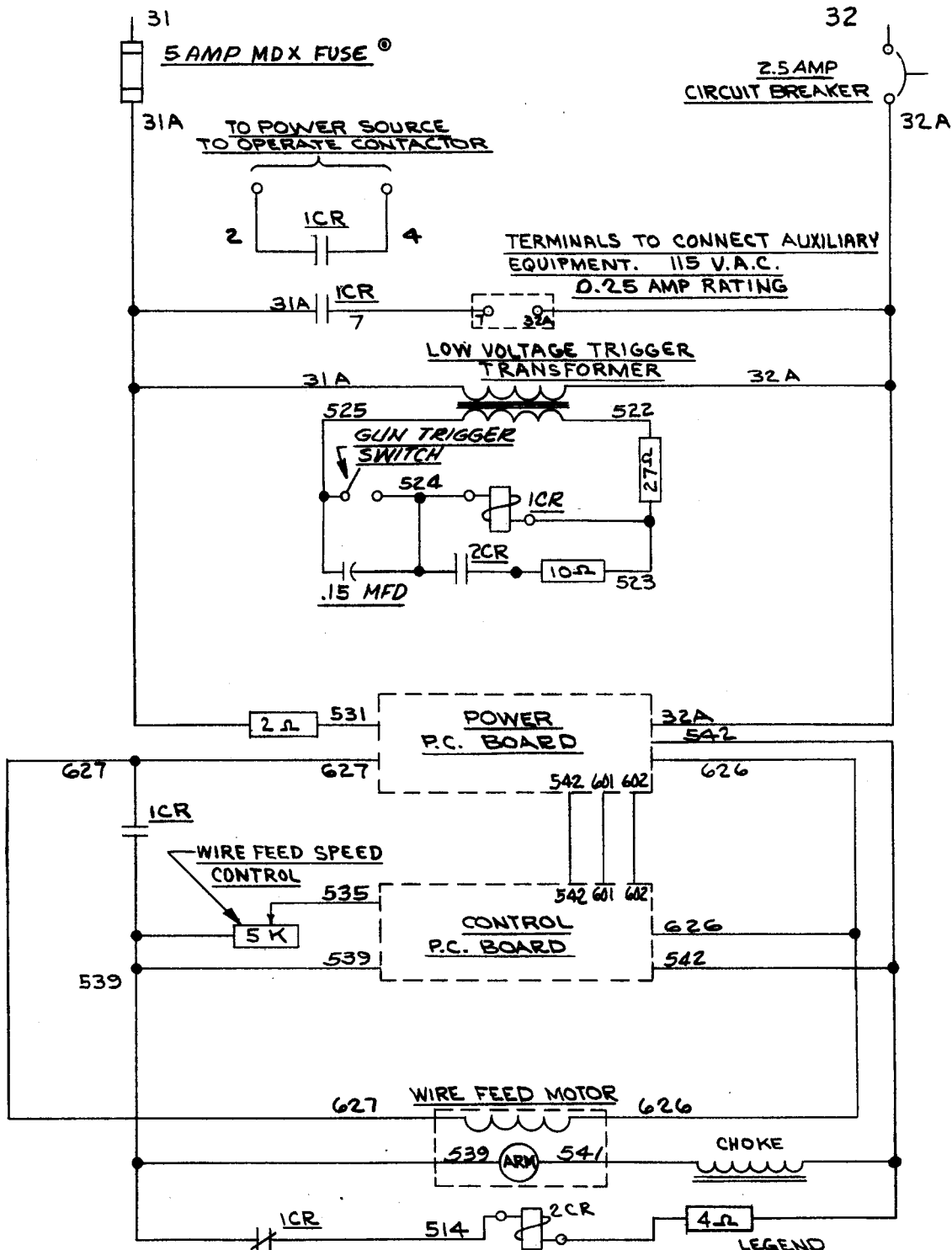

A.S.A. ELECTRICAL SYMBOLS

LEGEND  
ICR MAIN CONTROL RELAY  
2CR REED SWITCH-DYNAMIC  
BRAKE COIL AS'BLY.

© MAY BE REPLACED WITH A 5 AMP 125 V  
OR 250 V SLO BLD FUSE

10-8-71

# LN-7 WIRING DIAGRAM

For older machines built to Code 7024 only, request diagram M-12355.  
(Use M-12382 for Code 7024 A.)

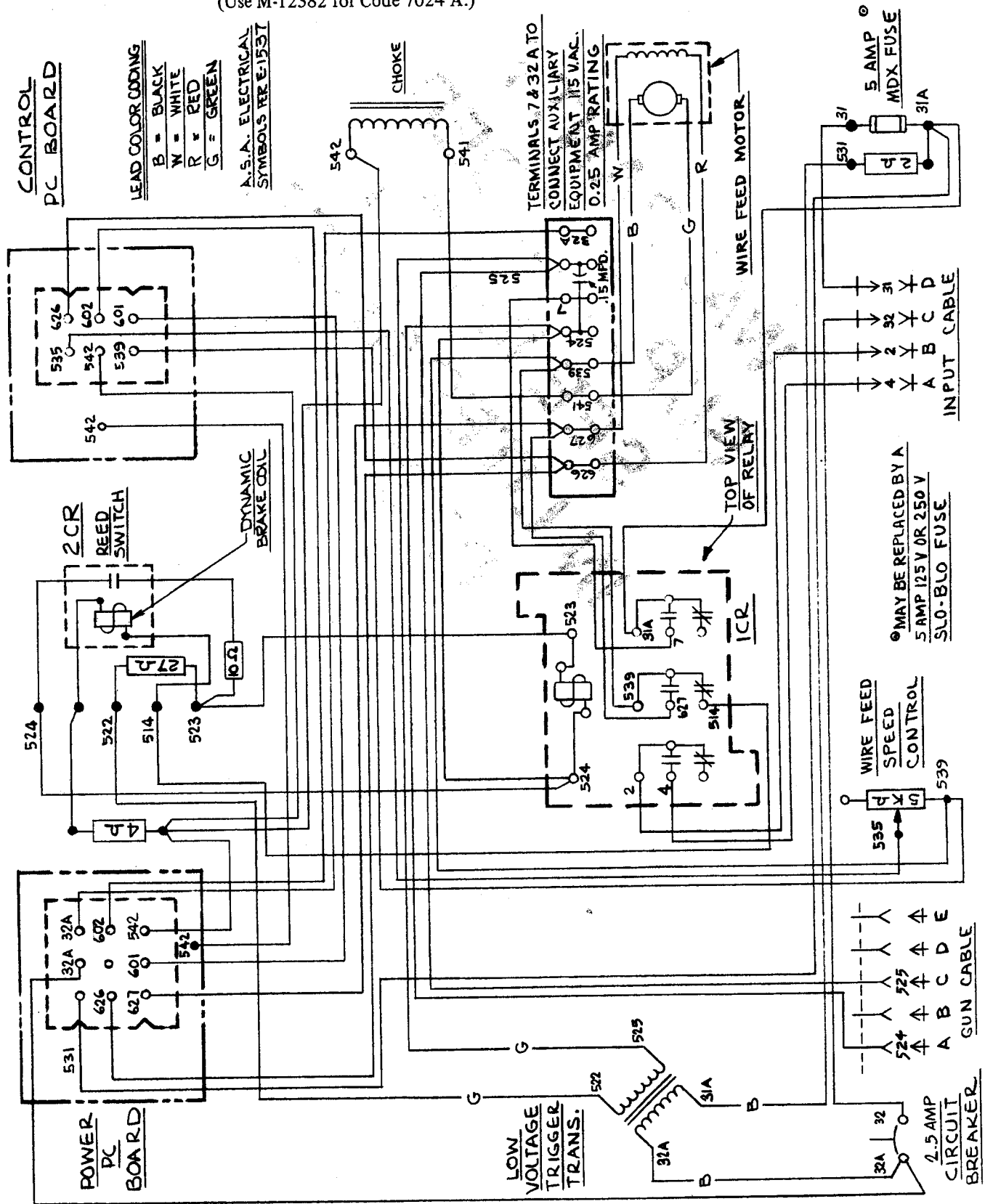

## HOW TO ORDER REPLACEMENT PARTS

Order parts only from Lincoln offices or from the Authorized Field Service Shops listed in the "Service Directory". Give the following information:

- (a) From the name and numbers.
- (b) From this manu

tion, item number, quantity required and the number of the list used to get this information.

Any items indented in the "Parts Name" column are included are listed. The indented of the entire assembly is parts.

The Lincoln Electric equipment except defects in workmanship from date of shipment properly cared for, Engines and engine defects for a period

If the Buyer gives the equipment or electrical and the Seller's ins defects, then the Seller its option, either by factory or other place provided Buyer hereby exclusive.

No expense, liability Seller for repairs made

consequential damages and conditions of any warranty. for the supplying of said by the Buyer, whether on any case exceed the cost of or replacing defective over guarantee. Upon the ty, all such liability shall

remedies are exclusive and there are no guarantees or warranties for accessories, equipment, or arising by operation of applied, including without liability, all such warran-

**WARRANTY SUPERSEDED  
SEE MWS 1**

**LINCOLN  
ELECTRIC**

## THE LINCOLN ELECTRIC COMPANY

World's Largest Manufacturer of Arc Welding Products • Manufacturer of Industrial Motors  
Sales and Service Worldwide  
Cleveland, Ohio 44117-1199 U.S.A.  
Toronto M4G 2B9 - Canada • Sydney 2211 - Australia • Rouen 76120 - France  
Litho in U.S.A.

Eff. Jan. '86

*Ram*

5-84