





## QUALITY SERVICE

Over sixty-five years of continuous service to the oil, gas and energy industry testifies to Greenwood Valves distinguished tradition of design innovation and customer satisfaction. Greenwood Valves engineers and skilled craftsmen turn concepts into finished products to meet the rigorous requirements of an ever-changing industry. New technologies meet new applications under the watchful supervision of professional engineers. Well versed in industry standards, codes, and expectations, Greenwood Valves is committed to solving the toughest pipeline and storage challenges.

## THE FIRST CHOICE IN SECONDARY VALVES

In an emergency, the ability to rapidly shut-off fluid and vapor flow can mean the difference between a manageable situation and a potential disaster. For over 60 years, Greenwood Quick Closing Valves have supplied that measure of safety.

These sturdy valves provide protection on pipelines and storage facilities in refineries, LPG, chemical, cement and power plants, shipyards, pumping stations, tank farms, and rail loading and unloading facilities throughout the world. As a secondary measure, Greenwood Valves provide isolation until primary emergency valves are reset and system safety is restored. Process materials include ammonia, butane propane, pentane, polypropylene, LNG, NGL, mild acids, diesel fuel and hot oil.

Greenwood Quick Closing Valves use a reverse check valve design to stop the flow of fluid or vapor in the event of emergency, be it fire, explosion or electrical disruption. Equipped with an external spring-assisted handle, closure is triggered by remote signal or alarm sent to electronic or pneumatic tripping devices. Fusible links which melt during a fire will allow quick closing. When resetting the valve to the normal open position, a proprietary internal relief valve breaks static pressure to help equalize pressure downstream.

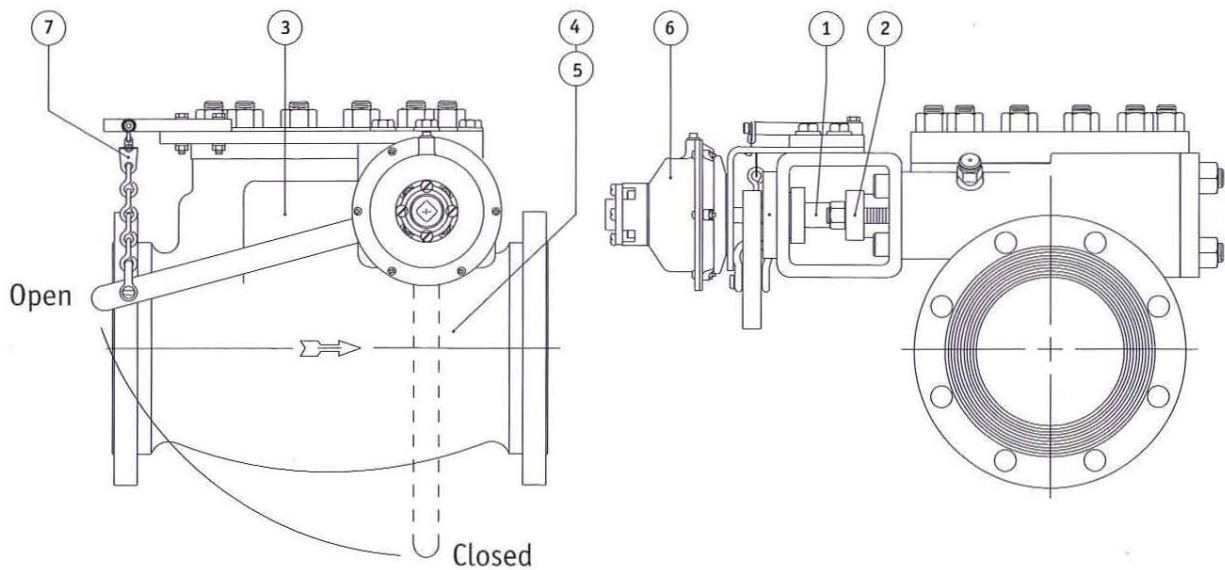

## STANDARD FEATURES

1. 3-point contact shaft design with radial & thrust bearings to provide ease of operation
2. Adjustable pull-down packing gland design to maximize packing performance
3. Cast steel body and stainless steel trim to withstand corrosive internal and external atmosphere
4. Internal relief valve to help equalize line pressure when resetting the valve
5. Lapped seat & disc to minimize leakage under pressure
6. Wound spring assembly to assure tight contact between disc and seat after valve closure
7. Fusible link assembly to activate unattended valves at elevated ambient temperatures

## OPTIONAL FEATURES

### Alternative methods to activate valve

1. Remote cable control to close valve manually
2. "Applied air" or "Air failure" for pneumatic operation
3. "Applied power" or "Power failure" for electrical operation
4. Explosion-proof limit switch for remote status indication
5. Alternative body materials to suit specific applications or environments
6. Injector fitting with internal lantern ring to lubricate shaft packing



## COMPLIES WITH CLEAN AIR ACT

Greenwood Valves exceed specifications outlined in the 1990 Amendment to the U.S. Government Clean Air Act for ambient and elevated temperature operation. Leakage measurements were performed by an independent testing laboratory in accordance with 40 CFR Part 60, Appendix A, Method 21 regulations. Design criteria and testing was completed in conjunction with a large local refinery to satisfy local Air Quality Management District regulations.

## MINIMAL MAINTENANCE

Periodic inspection and manual activation of each valve should be performed to insure smooth valve operation. Routine maintenance should include scheduled and authorized release of pneumatic systems and electric solenoids. Valves with the optional injection fittings on shaft seals should be lubricated as needed. Recommended spare parts include fusible links, shaft packing, cover gaskets and solenoids if the valve is equipped with electrical actuators.

### Order Spec Sheet

Size: \_\_\_\_\_ Service Conditions: \_\_\_\_\_ Min/Max Temp: \_\_\_\_\_

Pressure: \_\_\_\_\_ Product: \_\_\_\_\_

	Standard	Optional
Body	WCB	LCB, 304ss, 316ss
Trim	316ss	Consult Factory
Shaft	17-4Ph	Consult Factory
Packing	Graphaseal	N/A
BonGskt	Polycarbon	Spiral-wound
Actuator	Fusible Link	Pneumatic, Electric, Manual
Accessory	None	E.P. Limit Switch
Tests	API 598	N/A
Drawings/Docs	None	Certified/MTR's, HydroTest Report
Extras	None	Tags



## RUGGED CONSTRUCTION - EASY OPERATION

Greenwood Quick Closing Valves consist of a WCB-grade cast carbon steel body, 316 stainless steel trim, 17-4PH shaft material, and graphite cover gasket and shaft packing. Alternative methods of construction, available upon request.

All manufactured parts are produced on CNC machines to fabrication drawings produced on a CAD system. Stringent quality control is essential at every step of the manufacturing process. Every valve is tested to API standard No. 598 and issued a serial number.

Normally installed in a horizontal or down-flow position, Greenwood Valves remain in an open mode. The fusible link assembly holds the disc up out of the material flow until an emergency arises. Upon release, the spring-assisted handle & shaft assembly rotate the disc into the flow of the material. Pressure from the material flow compliments the spring assembly to insure a positive seal between the disc and seat.

After emergency conditions are resolved, the internal relief valve helps to equalize the line pressure when the external handle is reset to its normally open position. The fusible link and other optional electric or pneumatic release devices are, then placed into service.

## DIMENSIONS

Valve Size	Valve Class PSI	Connection Type	Face to Face	Actuator Clearance	Shaft Cover Clearance	Bonnet Clearance	Approximate Weight
2 in	150, 300, 600	Flanged	9-1/2 in	13 in	5 in	5 in	45
2 in	900	Flanged	13-1/2 in	13 in	5 in	6 in	80
3 in	150, 300	Flanged	12-1/2 in	14 in	6-1/2 in	6-1/2 in	80
3 in	600, 900	Flanged	15 in	14 in	6 in	8 in	115
4 in	150, 300	Flanged	15 in	17 in	8 in	10 in	200
4 in	400, 600	Flanged	16 in	17 in	8 in	10 in	210
4 in	900	Flanged	16-5/8 in	17 in	8 in	10 in	215
6 in	150, 300	Flanged	17-1/2 in	20 in	11 in	10 in	300
6 in	400, 600	Flanged	18-1/2 in	20 in	11 in	10 in	320
8 in	150, 300	Flanged	20 in	21 in	12 in	12 in	410
8 in	600	Flanged	21-5/8 in	21 in	12 in	12 in	440
10 in	150, 300	Flanged	24-1/2 in	21 in	13 in	13 in	750
12 in	150, 300	Flanged	26 in	24 in	14 in	13 in	920
14 in	150, 300	Flanged	31-1/4 in	25 in	15 in	16 in	1380
16 in	150, 300	Flanged	34-3/8 in	30 in	18 in	20 in	2700
18 in	150, 300	Flanged	36 in	26 in	16 in	19 in	2750
24 in	150	Flanged	45 in	29 in	19 in	20 in	3750

*Notes: Clearance dimensions approximate. Consult factory for further information. Dimensions are for fusible link only models. Optional release mechanisms, actuators, limit switches and other accessories will increase clearances required. Consult factory for specific models and configurations*

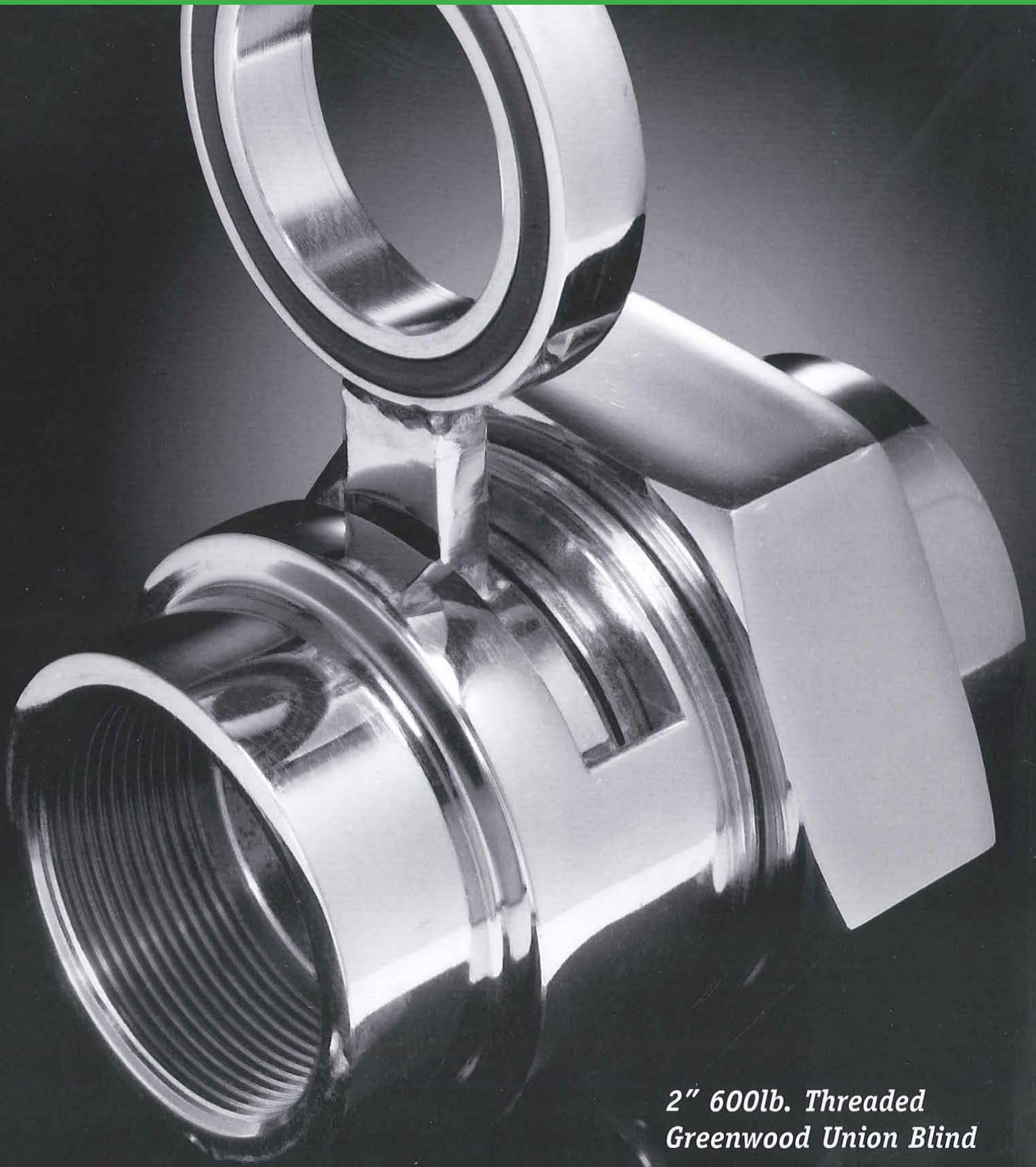

*2" 600lb. Threaded  
Greenwood Union Blind*



## GREENWOOD LINE BLIND UNIONS

Operating on the principle of a conventional threaded line union, the Greenwood Line Blind Union offers a simple and time-saving means of obtaining positive leak-proof shutoff. Common applications include compressor air and fuel lines, boiler and heater burner manifolds, storage tank foam lines and steam systems.

Greenwood Unions employ a reversible figure-B spectacle plate with O-rings to insure fully open and fully closed lines. A specially designed safety-slot is incorporated in the stationary seat to prevent spectacle blow-out. Simply loosen the nut to spread the seats, end-to-end the spectacle, and then re-tighten the nut to draw the seats together. O-ring seals on machined spectacles provide a positive seal against leakage.

### PARTS

No.	Req.	Part	Material
1	1	Spectacle	Stainless Steel
2	4	O-Rings	Viton Teflon
3	1	Hex Nut	Zinc Plated Carbon Steel
4	1	Moveable Seat	Stainless Steel
5	1	Stationary Seat	Stainless Steel
6	1	Retaining Ring	Stainless Steel
7	1	Safety Slot	

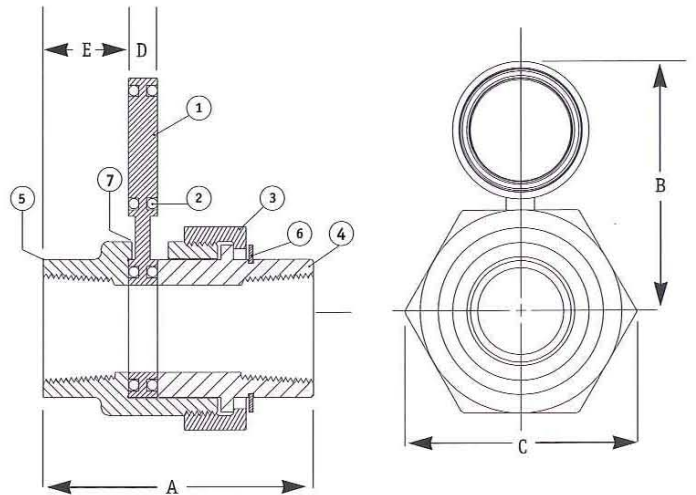

### DIMENSIONS

Description		Value Size (in) - #600				Value Size (in) - #3000			
		1/2 & 3/4	1	1-1/2	2	1/2 & 3/4	1	1-1/2	2
Overall Length Center to Top of Plate	A	3-7/8	4	4-3/4	4-7/8	4	4-3/4	4-7/8	5-5/8
Spectacle Max. Width Across	B	3	3-1/4	4-3/8	5-1/8	3-1/4	4-3/8	5-1/8	5-7/8
Corner of Nut Thickness of	C	2-3/8	2-3/4	2-3/4	4-3/8	2-3/4	2-3/4	4-3/8	5-5/8
Spectacle Plate Face of Valve	D	3/8	3/8	5/8	5/8	3/8	5/8	5/8	11/16
Spectacle Plate	E	1-1/4	1-1/4	1-1/2	1-1/2	1-1/4	1-1/2	1-1/2	3-3/8
Net Weight (lbs)	-	2-1/4	2-3/4	4-1/2	5-1/4	2-3/4	4-1/2	5-1/4	17

*2" Greenwood  
3 Bolt 150 lb. Bolt Blind*

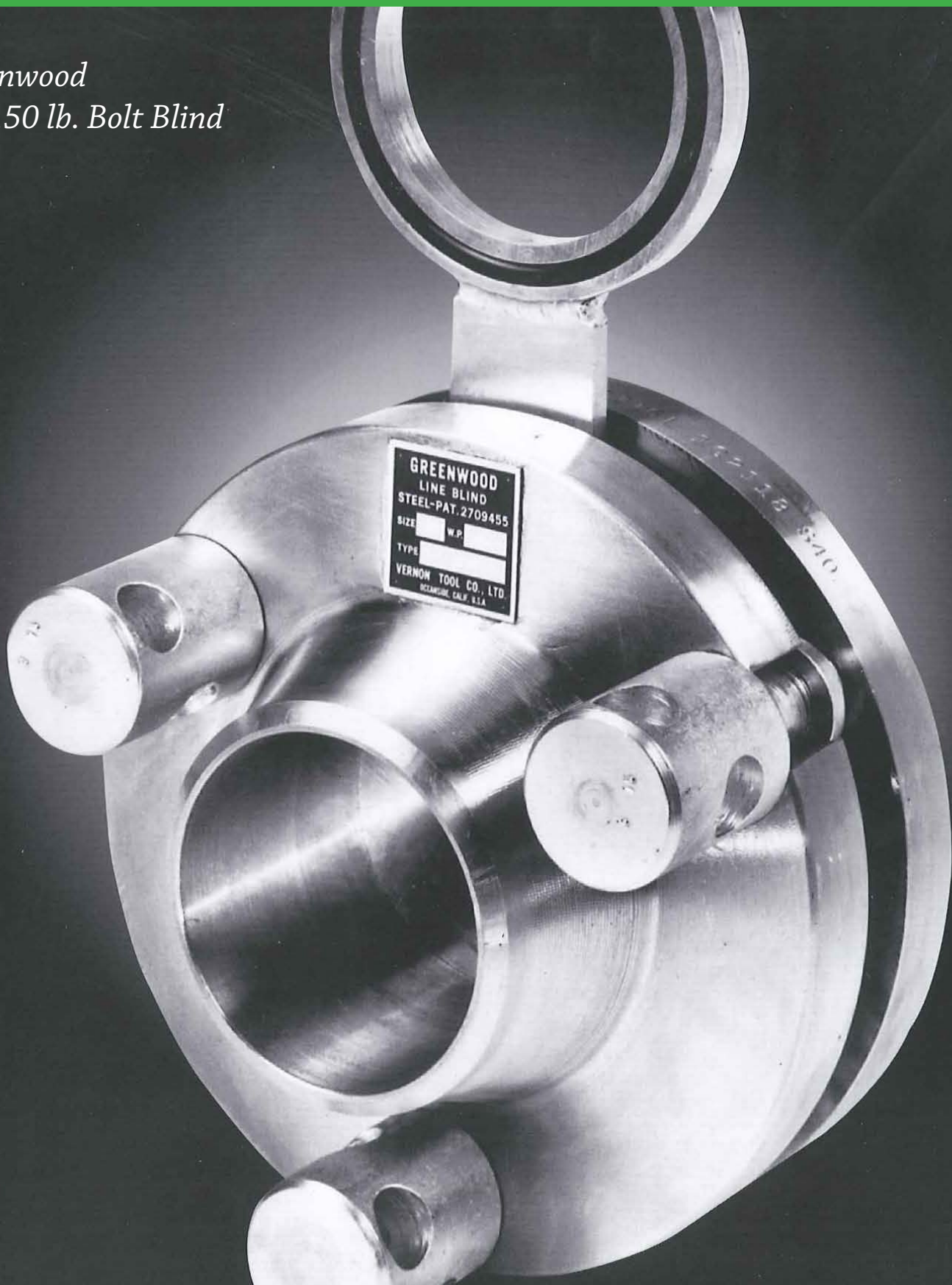





## GREENWOOD BOLTED LINE BLINDS

Similar to standard line unions, the Greenwood Bolted Line Blind is a labor-saving positive-seal means of opening and closing process lines. Frequently found in petrochemical and cement plants, bulk loading and storage terminals, LPG and LNG gathering systems, marine facilities, steel mills, and food processing facilities, Greenwood Bolted Line Blinds are an economical solution to positive flow and positive shut-off.

Three equally-spaced spreader bolts separate the flanges to free the figure-8 spectacle plate. Reverse the self-centering spectacle to the open position for a full bore flow connection with metal-to-metal seat and secondary O-ring seal. Re-tighten the spreader bolts to restore a leak-proof connection. O-ring grooves in the spectacle enable easy replacement of the seals. Stainless helicoils insure longer thread life and greater strength. Line status is clearly visible from a distance.

Standard blinds are available in carbon steel with butt-weld end connections with Viton seals. Pressure classes include 150 or 300 in either schedule 40, 80 or 160. Special materials, end connections or seals are available on request.

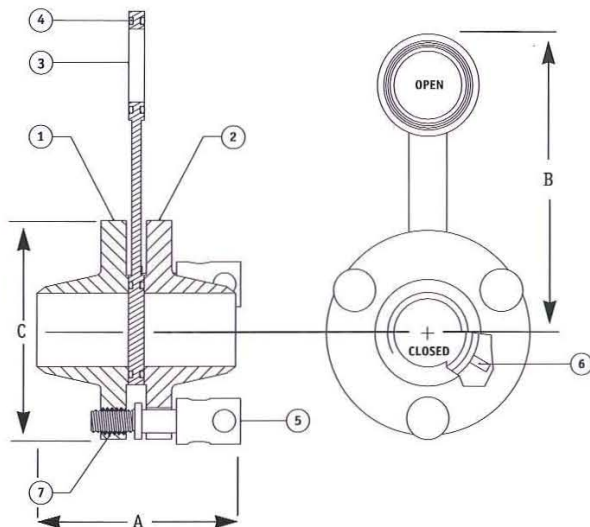

### PARTS

No.	Req.	Part	Material
1	1	Spectacle	Stainless Steel
2	4	O-Rings	Viton Teflon
3	1	Hex Nut	Stainless Steel
4	1	Moveable Seat	Stainless Steel
5	1	Stationary Seat	Stainless Steel
6	1	Retaining Ring	Stainless Steel
7	1	Safety Slot	

### DIMENSIONS (in)

Sizes	150 lbs			300 lbs		
	A	B	C	A	B	C
1/2	4-1/8	3	3-1/2	4-1/2	3	3-3/4
3/4	4-1/2	3-3/4	3-7/8	4-7/8	3-3/4	4-5/8
1	4-3/4	4-5/8	4-1/4	5-1/4	4-5/8	4-7/8
1-1/2	5-3/8	5-5/8	5	5-7/8	5-5/8	6-1/8
2	5-1/2	7-1/8	6	6-1/8	7-3/8	6-1/2
3	6	8-3/4	7-1/2	6-7/8	8-3/4	8-1/4
4	6-9/16	10-3/4	9	7-1/32	10-3/4	10
5	7-3/4	12-1/4	10	8-5/8	14	11
6	7-3/4	13-3/4	11	8-3/4	14	11
8	8-3/4	17-1/4	13-1/2	9-3/4	11-1/4	15
10	9	25-1/4	16	10-3/8	20-1/2	17-1/2
12	10-3/8	—	19	11-3/4	25	20-1/2
14	11	—	21	12-7/8	—	23
16	11-1/8	—	23-1/2	13-1/4	—	25-1/2
18	12-1/2	—	25	14-3/8	—	28
20	13	—	27-1/2	14-3/4	—	30-1/2



## SELF-CLOSING SAMPLING VALVES

Greenwood Self-closing Sampling Valves are designed to allow safe and quick sampling of volatile liquids under pressure on process lines, storage tanks or pressure vessels. Depressing the manual lever releases a spring-assisted plunger to draw off liquid. Releasing the lever reseats the Viton or Teflon seal against the valves machined seating surface. Standard sampling valves are 316 stainless steel. Flow reducers available upon request.

### PARTS

No.	Part
1	Body (3/4 in)
2	Stem
3	Valve Guide
4	Spring Cap
5	Lever
6	Lever Pivot
7	Spring
8	O-Ring
9	Spring Cap Gasket
10	Seal

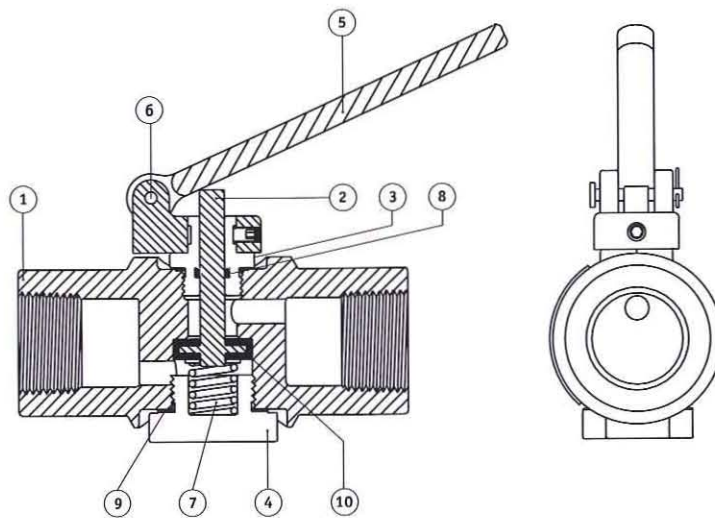

### SPECIFICATIONS

Size: 1/2 in. and 3/4 in. NPT

Pressure: ASME 300psi

Overall Length: 4 in.

Overall Weight: 2 lbs.

### INSTALLATION

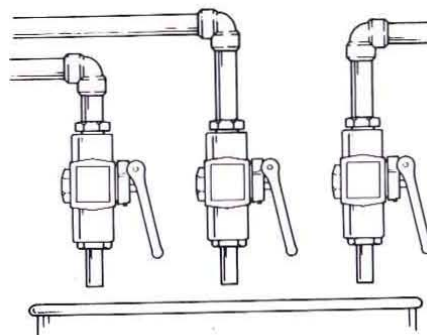



## AUTOMATIC DRAIN VALVE

Greenwood Automatic Drain Valves prevent the accumulation of fluids, condensation, or contaminants in fire lines, standpipes, and other pipelines. When the system is unpressurized, the internal spring tension exceeds the expected static head and the valve opens. This allows fluids to escape and reduces the danger of line freezing, rupture and corrosion. When line pressure is applied, the valve automatically closes and stops flow. All components are brass except the stainless steel Viton covered stem.

### PARTS

No.	Part
1	Body (3/4 in)
2	Stem
3	Cap
4	Spring
5	Lock Ring

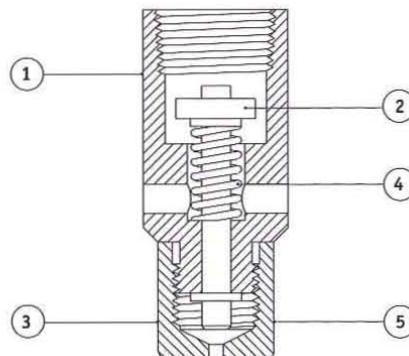

### SPECIFICATIONS

Size: 3/4 in. N.P.T. for static head up to 50 ft.

Pressure: A.N.S.I. 300 lbs.

Overall Length: 3 in.

Overall Weight: 1 lb.

Note: When ordering, specify normal line pressure and height of static column so proper spring tension can be furnished.

### INSTALLATION

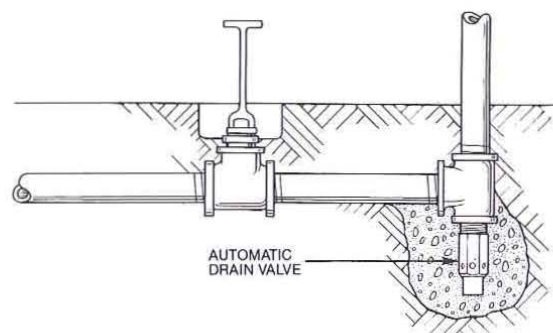

## TRADITION OF PRODUCT DEVELOPMENT...

New concepts, material and processes are integral to Greenwood Valve's business philosophy. Putting the right tools in the right hands ensures innovative, yet practical solutions to new and old challenges. Experienced professional engineers use state-of-the-art CAD system design and test product improvements before they reach the shop floor.

## SKILLED CRAFTSMANSHIP

From raw material through finished product, each component is precisely manufactured and carefully inspected for dimensional tolerance and surface quality. CNC machining operations and certified welding procedures result in successful tests to rigorous industry standards.

## QUALITY CONTROL

Greenwood Valve's stringent quality control program provides for continuous inspection of dimensions and surface finishes, ensuring precise clearance and proper operation of all moving parts.



### CUSTOMER ASSISTANCE POLICY

Greenwood Valve is manufacturing and selling high quality secondary valves. Our challenge is to meet the needs of our customers and to exceed their expectations. On occasion, purchasers may ask Greenwood Valve for information or advice about their use of our products. Our employees respond to inquiries to the best of their ability based on information provided to them by the customers and the knowledge they may have concerning the application. Our employees, however, are not in a position to verify the information provided or to evaluate the engineering requirements for the particular application. Accordingly, Greenwood Valve does not warrant or guarantee or assume any liability with respect to such information or advice. Moreover, the provision of such information or advice does not create, expand, or alter any warranty on our products. Any express or implied warranty that might arise from the information or advice, including any implied warranty of merchantability or any warranty of fitness for any customers' particular purpose is specifically disclaimed.

Greenwood Valve is a responsive manufacturer, but the selection and use of specific products sold by Greenwood is solely within the control of, and remains the sole responsibility of the customer. Many variables beyond the control of Greenwood Valve affect the results obtained when its products are used in various applications and service requirements.

Subject to Change – This information is accurate to the best of our knowledge at the time of printing. Please refer to [www.greenwoodvalve.com](http://www.greenwoodvalve.com) for any updated information.

### GREENWOOD VALVE

1177 N. Grove Street • Anaheim, CA • 92806 • U.S.A.  
Phone: +1.714.683.2430 • [www.greenwoodvalve.com](http://www.greenwoodvalve.com)