



NOTE: This manual will cover most of the troubleshooting and repair procedures for the code numbers listed. Some variances may exist when troubleshooting/repairing later code numbers.

PRECISION TIG 185

For use with machines having Code Numbers:

**11105, 11106, 11107,
11108, 11109**

SERVICE MANUAL

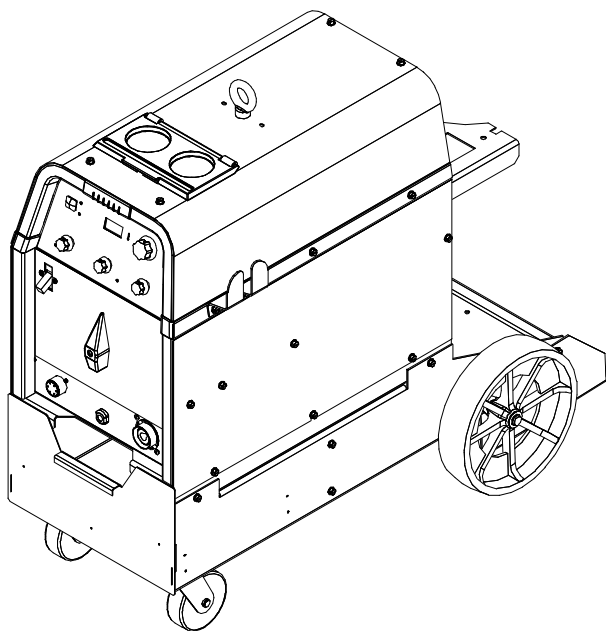

⚠ WARNING

⚠ CALIFORNIA PROPOSITION 65 WARNINGS ⚠

Diesel engine exhaust and some of its constituents are known to the State of California to cause cancer, birth defects, and other reproductive harm.

The Above For Diesel Engines

The engine exhaust from this product contains chemicals known to the State of California to cause cancer, birth defects, or other reproductive harm.

The Above For Gasoline Engines

ARC WELDING CAN BE HAZARDOUS. PROTECT YOURSELF AND OTHERS FROM POSSIBLE SERIOUS INJURY OR DEATH. KEEP CHILDREN AWAY. PACEMAKER WEARERS SHOULD CONSULT WITH THEIR DOCTOR BEFORE OPERATING.

Read and understand the following safety highlights. For additional safety information, it is strongly recommended that you purchase a copy of "Safety in Welding & Cutting - ANSI Standard Z49.1" from the American Welding Society, P.O. Box 351040, Miami, Florida 33135 or CSA Standard W117.2-1974. A Free copy of "Arc Welding Safety" booklet E205 is available from the Lincoln Electric Company, 22801 St. Clair Avenue, Cleveland, Ohio 44117-1199.

BE SURE THAT ALL INSTALLATION, OPERATION, MAINTENANCE AND REPAIR PROCEDURES ARE PERFORMED ONLY BY QUALIFIED INDIVIDUALS.



FOR ENGINE powered equipment.

1.a. Turn the engine off before troubleshooting and maintenance work unless the maintenance work requires it to be running.



1.b. Operate engines in open, well-ventilated areas or vent the engine exhaust fumes outdoors.



1.c. Do not add the fuel near an open flame welding arc or when the engine is running. Stop the engine and allow it to cool before refueling to prevent spilled fuel from vaporizing on contact with hot engine parts and igniting. Do not spill fuel when filling tank. If fuel is spilled, wipe it up and do not start engine until fumes have been eliminated.

1.d. Keep all equipment safety guards, covers and devices in position and in good repair. Keep hands, hair, clothing and tools away from V-belts, gears, fans and all other moving parts when starting, operating or repairing equipment.

1.e. In some cases it may be necessary to remove safety guards to perform required maintenance. Remove guards only when necessary and replace them when the maintenance requiring their removal is complete. Always use the greatest care when working near moving parts.



1.f. Do not put your hands near the engine fan. Do not attempt to override the governor or idler by pushing on the throttle control rods while the engine is running.

1.g. To prevent accidentally starting gasoline engines while turning the engine or welding generator during maintenance work, disconnect the spark plug wires, distributor cap or magneto wire as appropriate.



1.h. To avoid scalding, do not remove the radiator pressure cap when the engine is hot.

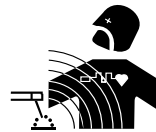

ELECTRIC AND MAGNETIC FIELDS may be dangerous

2.a. Electric current flowing through any conductor causes localized Electric and Magnetic Fields (EMF). Welding current creates EMF fields around welding cables and welding machines

2.b. EMF fields may interfere with some pacemakers, and welders having a pacemaker should consult their physician before welding.

2.c. Exposure to EMF fields in welding may have other health effects which are now not known.

2.d. All welders should use the following procedures in order to minimize exposure to EMF fields from the welding circuit:

2.d.1. Route the electrode and work cables together - Secure them with tape when possible.

2.d.2. Never coil the electrode lead around your body.

2.d.3. Do not place your body between the electrode and work cables. If the electrode cable is on your right side, the work cable should also be on your right side.

2.d.4. Connect the work cable to the workpiece as close as possible to the area being welded.

2.d.5. Do not work next to welding power source.

Mar '95

PRECISION TIG 185

LINCOLN
ELECTRIC



ELECTRIC SHOCK can kill.

3.a. The electrode and work (or ground) circuits are electrically "hot" when the welder is on. Do not touch these "hot" parts with your bare skin or wet clothing. Wear dry, hole-free gloves to insulate hands.

3.b. Insulate yourself from work and ground using dry insulation. Make certain the insulation is large enough to cover your full area of physical contact with work and ground.

In addition to the normal safety precautions, if welding must be performed under electrically hazardous conditions (in damp locations or while wearing wet clothing; on metal structures such as floors, gratings or scaffolds; when in cramped positions such as sitting, kneeling or lying, if there is a high risk of unavoidable or accidental contact with the workpiece or ground) use the following equipment:

- Semiautomatic DC Constant Voltage (Wire) Welder.
- DC Manual (Stick) Welder.
- AC Welder with Reduced Voltage Control.

3.c. In semiautomatic or automatic wire welding, the electrode, electrode reel, welding head, nozzle or semiautomatic welding gun are also electrically "hot".

3.d. Always be sure the work cable makes a good electrical connection with the metal being welded. The connection should be as close as possible to the area being welded.

3.e. Ground the work or metal to be welded to a good electrical (earth) ground.

3.f. Maintain the electrode holder, work clamp, welding cable and welding machine in good, safe operating condition. Replace damaged insulation.

3.g. Never dip the electrode in water for cooling.

3.h. Never simultaneously touch electrically "hot" parts of electrode holders connected to two welders because voltage between the two can be the total of the open circuit voltage of both welders.

3.i. When working above floor level, use a safety belt to protect yourself from a fall should you get a shock.

3.j. Also see Items 6.c. and 8.



ARC RAYS can burn.

4.a. Use a shield with the proper filter and cover plates to protect your eyes from sparks and the rays of the arc when welding or observing open arc welding. Headshield and filter lens should conform to ANSI Z87.1 standards.

4.b. Use suitable clothing made from durable flame-resistant material to protect your skin and that of your helpers from the arc rays.

4.c. Protect other nearby personnel with suitable, non-flammable screening and/or warn them not to watch the arc nor expose themselves to the arc rays or to hot spatter or metal.



FUMES AND GASES can be dangerous.

5.a. Welding may produce fumes and gases hazardous to health. Avoid breathing these fumes and gases. When welding, keep your head out of the fume. Use enough ventilation and/or exhaust at the arc to keep

fumes and gases away from the breathing zone. **When welding with electrodes which require special ventilation such as stainless or hard facing (see instructions on container or MSDS) or on lead or cadmium plated steel and other metals or coatings which produce highly toxic fumes, keep exposure as low as possible and below Threshold Limit Values (TLV) using local exhaust or mechanical ventilation. In confined spaces or in some circumstances, outdoors, a respirator may be required. Additional precautions are also required when welding on galvanized steel.**

5.b. Do not weld in locations near chlorinated hydrocarbon vapors coming from degreasing, cleaning or spraying operations. The heat and rays of the arc can react with solvent vapors to form phosgene, a highly toxic gas, and other irritating products.

5.c. Shielding gases used for arc welding can displace air and cause injury or death. Always use enough ventilation, especially in confined areas, to insure breathing air is safe.

5.d. Read and understand the manufacturer's instructions for this equipment and the consumables to be used, including the material safety data sheet (MSDS) and follow your employer's safety practices. MSDS forms are available from your welding distributor or from the manufacturer.

5.e. Also see item 1.b.

Mar '95

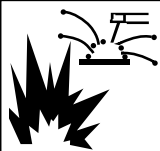

WELDING SPARKS can cause fire or explosion.

6.a. Remove fire hazards from the welding area.

If this is not possible, cover them to prevent the welding sparks from starting a fire.

Remember that welding sparks and hot

materials from welding can easily go through small cracks and openings to adjacent areas. Avoid welding near hydraulic lines. Have a fire extinguisher readily available.

6.b. Where compressed gases are to be used at the job site, special precautions should be used to prevent hazardous situations. Refer to "Safety in Welding and Cutting" (ANSI Standard Z49.1) and the operating information for the equipment being used.

6.c. When not welding, make certain no part of the electrode circuit is touching the work or ground. Accidental contact can cause overheating and create a fire hazard.

6.d. Do not heat, cut or weld tanks, drums or containers until the proper steps have been taken to insure that such procedures will not cause flammable or toxic vapors from substances inside. They can cause an explosion even though they have been "cleaned". For information, purchase "Recommended Safe Practices for the Preparation for Welding and Cutting of Containers and Piping That Have Held Hazardous Substances", AWS F4.1 from the American Welding Society (see address above).

6.e. Vent hollow castings or containers before heating, cutting or welding. They may explode.

6.f. Sparks and spatter are thrown from the welding arc. Wear oil free protective garments such as leather gloves, heavy shirt, cuffless trousers, high shoes and a cap over your hair. Wear ear plugs when welding out of position or in confined places. Always wear safety glasses with side shields when in a welding area.

6.g. Connect the work cable to the work as close to the welding area as practical. Work cables connected to the building framework or other locations away from the welding area increase the possibility of the welding current passing through lifting chains, crane cables or other alternate circuits. This can create fire hazards or overheat lifting chains or cables until they fail.

6.h. Also see item 1.c.

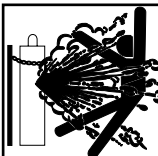

CYLINDER may explode if damaged.

7.a. Use only compressed gas cylinders containing the correct shielding gas for the process used and properly operating regulators designed for the gas and pressure used. All hoses, fittings, etc. should be suitable for the application and maintained in good condition.

7.b. Always keep cylinders in an upright position securely chained to an undercarriage or fixed support.

7.c. Cylinders should be located:

- Away from areas where they may be struck or subjected to physical damage.

- A safe distance from arc welding or cutting operations and any other source of heat, sparks, or flame.

7.d. Never allow the electrode, electrode holder or any other electrically "hot" parts to touch a cylinder.

7.e. Keep your head and face away from the cylinder valve outlet when opening the cylinder valve.

7.f. Valve protection caps should always be in place and hand tight except when the cylinder is in use or connected for use.

7.g. Read and follow the instructions on compressed gas cylinders, associated equipment, and CGA publication P-1, "Precautions for Safe Handling of Compressed Gases in Cylinders," available from the Compressed Gas Association 1235 Jefferson Davis Highway, Arlington, VA 22202.



FOR ELECTRICALLY powered equipment.

8.a. Turn off input power using the disconnect switch at the fuse box before working on the equipment.

8.b. Install equipment in accordance with the U.S. National Electrical Code, all local codes and the manufacturer's recommendations.

8.c. Ground the equipment in accordance with the U.S. National Electrical Code and the manufacturer's recommendations.

Mar '95

PRÉCAUTIONS DE SÛRETÉ

Pour votre propre protection lire et observer toutes les instructions et les précautions de sûreté spécifiques qui paraissent dans ce manuel aussi bien que les précautions de sûreté générales suivantes:

Sûreté Pour Soudage A L'Arc

1. Protégez-vous contre la secousse électrique:
 - a. Les circuits à l'électrode et à la pièce sont sous tension quand la machine à souder est en marche. Eviter toujours tout contact entre les parties sous tension et la peau nue ou les vêtements mouillés. Porter des gants secs et sans trous pour isoler les mains.
 - b. Faire très attention de bien s'isoler de la masse quand on soude dans des endroits humides, ou sur un plancher métallique ou des grilles métalliques, principalement dans les positions assis ou couché pour lesquelles une grande partie du corps peut être en contact avec la masse.
 - c. Maintenir le porte-électrode, la pince de masse, le câble de soudage et la machine à souder en bon et sûr état de fonctionnement.
 - d. Ne jamais plonger le porte-électrode dans l'eau pour le refroidir.
 - e. Ne jamais toucher simultanément les parties sous tension des porte-électrodes connectés à deux machines à souder parce que la tension entre les deux pinces peut être le total de la tension à vide des deux machines.
 - f. Si on utilise la machine à souder comme une source de courant pour soudage semi-automatique, ces précautions pour le porte-électrode s'appliquent aussi au pistolet de soudage.
2. Dans le cas de travail au dessus du niveau du sol, se protéger contre les chutes dans le cas où on recoit un choc. Ne jamais enrouler le câble-électrode autour de n'importe quelle partie du corps.
3. Un coup d'arc peut être plus sévère qu'un coup de soleil, donc:
 - a. Utiliser un bon masque avec un verre filtrant approprié ainsi qu'un verre blanc afin de se protéger les yeux du rayonnement de l'arc et des projections quand on soude ou quand on regarde l'arc.
 - b. Porter des vêtements convenables afin de protéger la peau de soudeur et des aides contre le rayonnement de l'arc.
 - c. Protéger l'autre personnel travaillant à proximité au soudage à l'aide d'écrans appropriés et non-inflammables.
4. Des gouttes de laitier en fusion sont émises de l'arc de soudage. Se protéger avec des vêtements de protection libres de l'huile, tels que les gants en cuir, chemise épaisse, pantalons sans revers, et chaussures montantes.
5. Toujours porter des lunettes de sécurité dans la zone de soudage. Utiliser des lunettes avec écrans latéraux dans les

zones où l'on pique le laitier.

6. Eloigner les matériaux inflammables ou les recouvrir afin de prévenir tout risque d'incendie dû aux étincelles.
7. Quand on ne soude pas, poser la pince à un endroit isolé de la masse. Un court-circuit accidentel peut provoquer un échauffement et un risque d'incendie.
8. S'assurer que la masse est connectée le plus près possible de la zone de travail qu'il est pratique de le faire. Si on place la masse sur la charpente de la construction ou d'autres endroits éloignés de la zone de travail, on augmente le risque de voir passer le courant de soudage par les chaînes de levage, câbles de grue, ou autres circuits. Cela peut provoquer des risques d'incendie ou d'échauffement des chaînes et des câbles jusqu'à ce qu'ils se rompent.
9. Assurer une ventilation suffisante dans la zone de soudage. Ceci est particulièrement important pour le soudage de tôles galvanisées plombées, ou cadmiées ou tout autre métal qui produit des fumées toxiques.
10. Ne pas souder en présence de vapeurs de chlore provenant d'opérations de dégraissage, nettoyage ou pistolage. La chaleur ou les rayons de l'arc peuvent réagir avec les vapeurs du solvant pour produire du phosgène (gas fortement toxique) ou autres produits irritants.
11. Pour obtenir de plus amples renseignements sur la sûreté, voir le code "Code for safety in welding and cutting" CSA Standard W 117.2-1974.

PRÉCAUTIONS DE SÛRETÉ POUR LES MACHINES À SOUDER À TRANSFORMATEUR ET À REDRESSEUR

1. Relier à la terre le châssis du poste conformément au code de l'électricité et aux recommandations du fabricant. Le dispositif de montage ou la pièce à souder doit être branché à une bonne mise à la terre.
2. Autant que possible, l'installation et l'entretien du poste seront effectués par un électricien qualifié.
3. Avant de faire des travaux à l'intérieur de poste, la débrancher à l'interrupteur à la boîte de fusibles.
4. Garder tous les couvercles et dispositifs de sûreté à leur place.

PRECISION TIG 185



MASTER TABLE OF CONTENTS FOR ALL SECTIONS

Safety	i-iv
Installation	Section A
Operation	Section B
Accessories	Section C
Maintenance	Section D
Theory of Operation	Section E
Troubleshooting and Repair	Section F
Electrical Diagrams	Section G
Parts ManualP499 Series

TABLE OF CONTENTS - INSTALLATION SECTION -

InstallationSection A

Technical SpecificationsA-2/A-3

Safety PrecautionsA-4

Location.....A-4

 GrindingA-4

 StackingA-4

 Lifting and MovingA-4

 TiltingA-4

 Environmental Rating.....A-4

Machine Grounding and High Frequency Interference ProtectionA-4

Input Connections.....A-5

Input Reconnect ProcedureA-6

Output Connections.....A-6

 Connections for TIG WeldingA-6

 TIG Torch ConnectionA-6

 Work Cable ConnectionA-7

 Shielding Gas Connection.....A-7

 Remote Control Connection.....A-7

Connections for Stick Welding.....A-7

 Stick Electrode Cable and Work Cable ConnectionA-7

Return to Master TOC

Return to Master TOC

Return to Master TOC

Return to Master TOC

TECHNICAL SPECIFICATIONS - PRECISION TIG 185 (K2345-1 AND K2347-1,-2)

INPUT - SINGLE PHASE ONLY

Standard Voltage 208/230/1/60	Input Current at Rated Output 35A / 32A Effective and 70A / 64A Maximum
---	--

OUTPUT RANGE

Output Current Range 7-185 Amps (AC) 5-185 Amps (DC)	Maximum Open Circuit Voltage (STICK AND TIG) AC OCV: 75 DC OCV: 59	Type of Output CC (Constant Current) AC/DC
---	--	---

RATED OUTPUT

Duty Cycle GTAW 15% Duty Cycle 100% Duty Cycle SMAW 15% Duty Cycle 100% Duty Cycle	Amps 185A AC/DC 90A AC/DC (BAL) 70A AC (AUTO-BAL) 185A AC/DC/125 90A AC/DC	Volts at Rated Amperes 15.2 V AC/DC 14.1 V AC/DC 13.8 V AC/DC 27.4 V AC/DC 23.6 V AC/DC
---	--	---

Chart gives max. rated Output Amps @ % Duty Cycle (Based on a 10 minute cycle)
 (Example; 110A@60% for AC/DC Stick and Balance TIG)

Using standard #8-3 input cable for protected⁽¹⁾ input supply

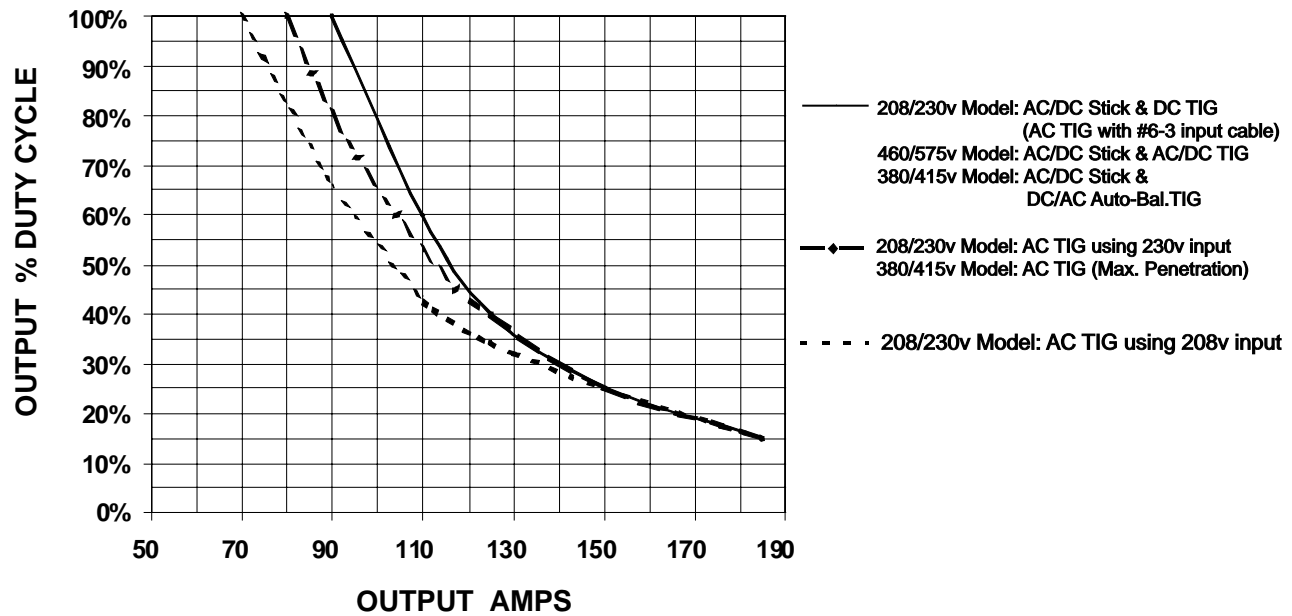

⁽¹⁾ Wiring and protection based on the 2002 U.S. National Electric Code:
 Use a Super Lag type fuse or circuit breaker with a delay in tripping action.
 Models with NEMA 6-50P plug may be used with a 50 amp protected 6-50R receptacle, or
 with a maximum 70 amp protected 6-50R receptacle if dedicated for the welder.

PRECISION TIG 185



Return to Section TOC

Return to Section TOC

Return to Section TOC

Return to Section TOC

Return to Master TOC

Return to Master TOC

Return to Master TOC

Return to Master TOC

TECHNICAL SPECIFICATIONS - CANADIAN (K2345-2), INTERNATIONAL K2346-1)

K2345-2 INPUT (at Rated Output)

<u>Voltage/Phase/Freq.</u>	<u>Current</u>	<u>Power Factor</u>	<u>Idle Current</u>
460/575/1/60 	16 A/13 A Effective 32 A/26 A Max.	0.62 Min.	1.3 A/1.0 A Max.

K2346-1 INPUT (at Rated Output)

<u>Voltage/Phase/Freq.</u>	<u>Current</u>	<u>Power Factor</u>	<u>Idle Current</u>
380/400-415/1/50/60 	19 A/18 A Effective 39 A/37 A Max.	0.62 Min.	1.3 A/1.0 A Max.

OUTPUT RANGE

<u>Max. OCV.</u>	<u>Weld Current</u>	<u>Output Type</u>
74 V (AC) 59 V (DC)	7-185 A (AC) 5-185 A (DC).	CC (Constant Current) AC or DC

RATED OUTPUT

<u>Process Duty Cycle*</u>	<u>Weld Current</u>	<u>Weld Voltage (NEMA)</u>
SMAW 15%	185 A AC/DC	27.4 V
100%	90 A AC/DC	23.6 V
GTAW 15%	185 A AC/DC	15.2 V
100%	90 A AC/DC (Auto-Bal.)	14.1 V

* Based on a 10 minute cycle.

PHYSICAL DIMENSIONS⁽²⁾

MODEL	HEIGHT	WIDTH	DEPTH	WEIGHT
Machine Only (K2345-1,-2) (K2346-1)	20.71 in. 526 mm	14.48 in. 368 mm	25.62 in. 751 mm	Approx. 192 lbs. 87.1 kgs
Ready-Pak (K2347-1)	20.71 in. 526 mm	14.48 in. 368 mm	25.62 in. 651 mm	Approx. 212lbs.. 96.2 kgs.
Ready-PakW/Cart (K2347-2)	31.24 in. 794 mm	19.81 in. 503 mm	38.01 in. 966 mm	Approx. 258lbs. 117.0 kgs.

⁽²⁾ Dimensions are without Lift Eyebolt and Torch Holder

PRECISION TIG 185



SAFETY PRECAUTIONS

Read entire installation section before starting installation.

⚠ WARNING



ELECTRIC SHOCK can kill.

- Only qualified personnel should perform this installation.
- Turn the input power OFF at the disconnect switch or fuse box before working on this equipment.

- Do not touch electrically hot parts.
- Always connect the SQUARE WAVE TIG 175 PRO to a power supply grounded per the National Electrical Code and any local codes.

SELECT SUITABLE LOCATION

Place the welder where clean cooling air can freely circulate in and out through the rear louvers. Dirt, dust or any foreign material that can be drawn into the welder should be kept at a minimum. Failure to observe these precautions can result in excessive operating temperatures and nuisance shut-downs.

GRINDING

Do not direct grinding particles towards the welder. An abundance of conductive material can cause maintenance problems.

STACKING

Square Wave TIG 185 **cannot** be stacked.

LIFTING AND MOVING

The Precision TIG 185 models are provided with an Eyebolt used for lifting the unit with a hoist. To install; remove the plug button from the case top and screw the Eyebolt securely into the threaded bracket beneath the case top per the below instructions and warnings provided on the case top decal. Save the removed plug button (LE part No.T10397-2) to cover the hole when the lift Eyebolt is removed.

⚠ WARNING



FALLING EQUIPMENT cause injury.

- Lift only with equipment of adequate lifting
- Be sure machine is stable when lifting.

- Use only Lincoln provided T4550-5 1/2-13 x 1.00 eyebolt.
- Fully engage threads and torque eyebolt to 38 ft. lbs.
- Re-torque eyebolt to 38 ft. lbs. before each lift.
- Lift only with equipment of adequate lifting capacity.
- Never lift welder with gas cylinder attached.
- Never lift welder above personnel.

An undercarriage, provided on the Ready-Pak w/Cart model, is also available to easily move the the unit. Refer to the Accessories section of this manual.

Do not attempt to lift the power source with an undercarriage attached.

The undercarriage is designed for hand moving only; mechanized movement can lead to personal injury and/or damage to the Precision TIG 185.

TILTING

Each machine must be placed on a secure, level surface, either directly or on a recommended undercarriage. The machine may topple over if this procedure is not followed.

ENVIRONMENTAL RATING

The PRECISION TIG 185 power source carries an IP21 environmental rating. It may be used in normal industrial and commercial environments. Avoid using it in environments which have falling water such as rain.

Read and follow "Electric Shock Warnings" in the Safety section if welding must be performed under electrically hazardous conditions such as welding in wet areas or on or in the workpiece.

MACHINE GROUNDING AND HIGH FREQUENCY INTERFERENCE PROTECTION

This welder must be grounded! See your local and national electrical codes for proper grounding methods.

PRECISION TIG 185



INPUT RECONNECT PROCEDURE

On multiple input voltage welders, be sure the machine is connected per the following instructions for the voltage being supplied to the welder.

CAUTION

Failure to follow these instructions can cause immediate failure of components within the welder and void machine's warranty.

Multiple voltage models are shipped connected for the highest voltage. To change this connection refer to the following instructions.

WARNING



ELECTRIC SHOCK can kill.

- Turn the input power OFF at the disconnect switch or fuse box before working on this equipment.

For the lowest rated voltage connection (Refer to figure A.1):

1. Remove the sheet metal left side cover.
2. Disconnect lead H3 from the power switch and insulate with the insulation from the H2 lead.
3. Connect lead H2 to the power switch where H3 was connected.
4. Tighten connections.
5. Replace sheet metal cover and all screws

For the highest rated voltage connection (Refer to figure A.1):

The machine is normally shipped connected for the highest rated voltage, however verify the following:

1. Remove the sheet metal left side cover.
2. Disconnect lead H2 from the power switch and insulate with the insulation from the H3 lead.
3. Connect lead H3 to the line switch where H2 was connected.
4. Tighten connections.
5. Replace sheet metal cover and all screws.

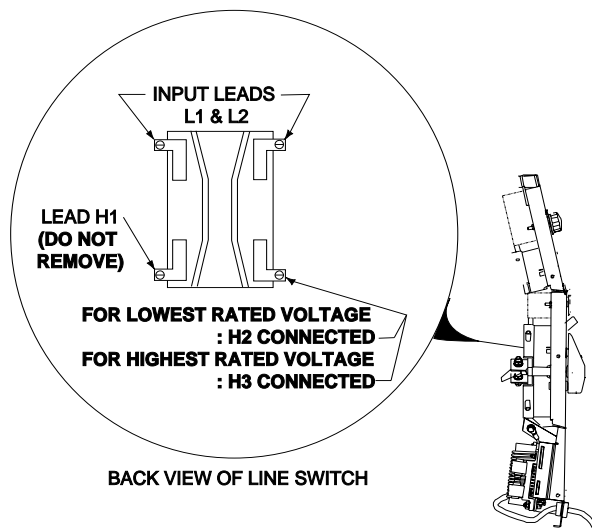

FIGURE A.1 Reconnect Leads

OUTPUT CONNECTIONS

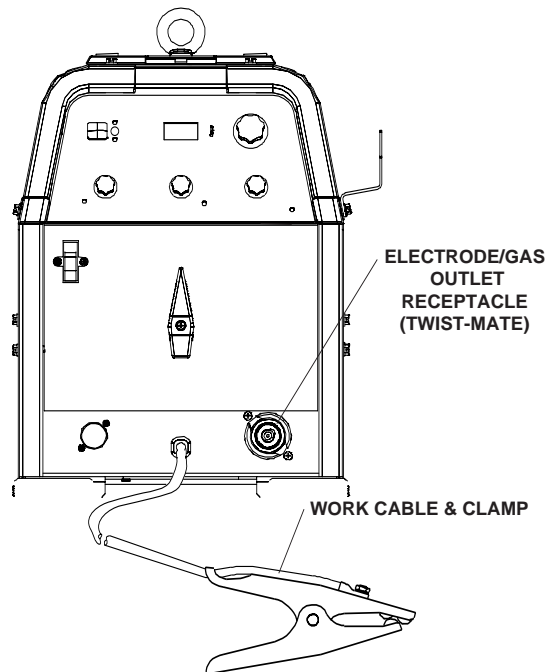

FIGURE A.2 Location of Output Connections

CONNECTIONS FOR TIG (GTAW) WELDING

TIG TORCH CONNECTION

Refer to **Included Equipment** in the Operation Section of this manual for TIG welding equipment which is included with the PRECISION TIG 185.

PRECISION TIG 185



A PTA-17 Twist-Mate TIG welding torch with cable and connector is supplied with the Ready-Pak Models and available for other models (See **Accessories** Section). Turn the Power Switch "OFF". Connect the torch cable Twist-Mate quick connect plug into the Electrode/Gas Output Receptacle on the front of the welder and turn it clockwise until it is tight. This is a Twist-Mate quick connect terminal and also provides the gas connection for the shielding gas to the torch.

⚠ WARNING

To avoid receiving a high frequency shock, keep the TIG torch and cables in good condition.

WORK CABLE CONNECTION

A work cable with attached work clamp is factory connected to the PRECISION TIG 185. To minimize high frequency interference, refer to **Machine Grounding and High Frequency Interference Protection** section of this manual for the proper procedure on grounding the work clamp and work piece.

SHIELDING GAS CONNECTION

An adjustable gas pressure regulator with flow gage and hose is supplied with the PRECISION TIG 185 Ready-Pak Models and available separately for other models (See **Accessories** Section). Obtain the necessary inert shielding gas (usually argon). Connect the cylinder of gas with the pressure regulator and flow gage. Install the gas hose between the regulator and gas inlet (located on the rear of the welder). The gas inlet has a 5/16-18 right hand female thread; CGA#032.

The available Under-Storage Cart features a low platform that simplifies loading and unloading of gas cylinders.

⚠ WARNING



CYLINDER could explode if damaged.

- Keep cylinder upright and chained to a support.
- Keep cylinder away from areas where it could be damaged.
- Never allow the torch to touch the cylinder.
- Keep cylinder away from live electrical circuits.
- Maximum inlet pressure 150 psi.

A cylinder is loaded by leaning it slightly sideways and rocking it up on the platform, being careful not to allow the Under-Storage Cart to roll. **Secure the cylinder in place with the provided chain.** Unload by following these steps in reverse.

REMOTE CONTROL CONNECTION

A remote control receptacle is provided on the case front of the welder for connecting a remote control to the machine. A Foot Amptrol™, foot activated remote control, is included with the PRECISION TIG 185 Ready-Pak models and available separately for other models. Refer to the **Optional Accessories** section of this manual for other available remote controls.

CONNECTIONS FOR STICK (SMAW) WELDING

STICK ELECTRODE CABLE AND WORK CABLE CONNECTION

Refer to Field Installed Options in Accessories Section of this manual for STICK welding equipment which is available for use with the PRECISION TIG 185. An electrode holder with Twist-Mate cable and Twist-Mate connector are available separately for use with the PRECISION TIG 185. (See **Accessories** Section). Turn the Power Switch "OFF". Connect the Twist-Mate quick connect plug into the Electrode/Gas Output Receptacle and turn it clockwise until it is tight. The work cable and work clamp are factory connected.

Return to Section TOC
Return to Master TOC

Return to Section TOC
Return to Master TOC

Return to Section TOC
Return to Master TOC

Return to Section TOC
Return to Master TOC

PRECISION TIG 185



TABLE OF CONTENTS - OPERATION SECTION -

Return to Master TOC

Return to Master TOC

Return to Master TOC

Return to Master TOC

OperationSection B

Safety PrecautionsB-2

Graphic Symbols.....B-2

Product Description.....B-3

Recommended Processes and Equipment.....B-3

Welding Capability (duty cycle)B-3

Controls and Settings.....B-4

Control FunctionalityB-4/B-5

Operating StepsB-5

Welding in TIG Mode.....B-5

Pulse TIG ControlB-5

Remote Control OperationB-6

Benefits of the Precision TIG 185 DesignB-6

Welding in Stick ModeB-7

Recommended Electrode Amperage Ranges.....B-7

SAFETY PRECAUTIONS

Read and understand this entire section before operating the machine.

WARNING



ELECTRIC SHOCK

can kill.

- Do not touch electrically live parts or electrode with skin or wet clothing.
- Insulate yourself from work and ground.

- Always wear dry insulating gloves.
- Read and follow “Electric Shock Warnings” in the Safety section if welding must be performed under electrically hazardous conditions such as welding in wet areas or on or in the workpiece.



FUMES AND GASES

can be dangerous.

- Keep your head out of fumes.
- Use ventilation or exhaust at the arc, or both, to remove fumes and gases from breathing zone and general area.

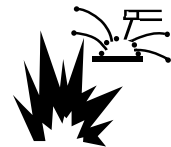

WELDING SPARKS can cause fire or explosion

- Keep flammable material away.
- Do not weld on containers that have held combustibles.



ARC RAYS can burn.

- Wear eye, ear and body protection.

Observe additional Safety Guidelines detailed in the beginning of this manual.

GRAPHIC SYMBOLS THAT APPEAR ON THIS MACHINE OR IN THIS MANUAL



INPUT POWER



POSITIVE OUTPUT



NEGATIVE OUTPUT



DIRECT CURRENT



PROTECTIVE GROUND



WARNING OR CAUTION

DO NOT SWITCH WHILE WELDING

Return to Section TOC

Return to Section TOC

Return to Section TOC

Return to Section TOC

Return to Master TOC

Return to Master TOC

Return to Master TOC

Return to Master TOC

PRODUCT DESCRIPTION

The Precision TIG 185 is a member of our field acclaimed Precision TIG family of industrial arc weld-ing power sources. Premium features include:

1. Precise constant current output.
2. Full range square wave AC/DC TIG (GTAW) weld-ing.
3. Enhanced version of the patented Micro-Start™Technology for its lower Minimum(5 amps) to higher Maximum (185 amps) output control range.
4. Built-in high frequency stabilization for DC TIG start-ing and continuous AC TIG welding.
5. AC/DC Stick (SMAW capability.) A new undercar-riage (with gas bottle rack) is available for field installation, or is included with an available Ready-Pak TIG Welding Package. The Precision TIG patented convenient built-in storage provisions for welding components and cable management.

The Precision TIG 185 also provides advanced fea-tures such as:

- Digital Meter
- Presetable control, adjustable Auto Balance™
- Fan As Needed (F.A.N.)
- Timers for fixed Preflow and variable Postflow shield-ing gas.
- Built-in, easy to set single knob Pulse TIG control with a "blinking" light to indicate the pulse frequency set-ting.
- Auto-Sense remote control selection.
- Tool-less Twist-Mate electrode cable connection.
- Built-in work clamp cable permanently attached.

Four models are available for 60Hz. with Domestic and Canadian input voltages, as well as an International model with 50/60Hz voltages.

RECOMMENDED PROCESSES AND EQUIPMENT

RECOMMENDED PROCESSES

The Precision TIG 185 is recommended for the TIG (GTAW) and Stick (SMAW) welding processes within its output capacity range of 5 amps DC, or 7 amps AC, to 185 amps AC/DC. It is compatible with most Magnum TIG accessories, as well as many industry standard items, such as TIG torches (adapted for Twist-Mate), hoses, and water coolers.

PROCESS LIMITATIONS

The Precision TIG machines are not recommended for arc gouging due to it's limited output capacity, and are also not recommended for pipe thawing.

RECOMMENDED EQUIPMENT/INTERFACE

(See Installed Options in Accessories Section for more details)

The Precision TIG 185 will be available as a basic Machine (Only) and in two Factory-Configured Welding Packages:

1. Machine(Only) (K2345-1)
2. Ready-Pak (K2347-1)
3. Ready-Pak w/Cart (K2347-2)

Basic module will also be available as with Domestic, Canadian and International input voltages for user con-figuration, with optional accessories.

Select Machine	208/230/1/60 Machine with 6 NEMA 6-50P Plug Cable and Receptacle (K2345-1) 460/575/1/60 Machine only with cable (K2345-2) 380/400/415/1/50/60 Machine only with cable (K2346-1)	
Torch Starter Kit (Select one)	Air Cooled System: TIG-Mate Torch Starter Kit*	Water Cooled System: TIG-Mate 20 Torch Starter Kit*
Water Cooler	Not Applicable	115V 50/60Hz Cool-Arc 40*
Under-Storage Cart (Optional)	K2348-(*)	
Optional Remote Trigger Device (Select one)	Arc Start Switch* Foot Amptrol* Start Pedal Foot Amptrol* Hand Amptrol*	

*For "Part Numbers" or "K Numbers" see Accessories Section.

EQUIPMENT LIMITATIONS

The Precision TIG machines are protected from over loads beyond the output ratings and duty cycles, per the Specifications in the Installation Section, with Thermostat protection of the output power coils and rectifiers.

The PRECISION TIG 185 machine uses Twist-Mate output terminals, therefore stud connection adapters (such as LECO. S19257-series) cannot be used for torch connection.

If a Precision Tig 185 is powered from an engine gen-erator which doesn't have sufficient capacity, the AC Balance control and the Output control will not provide full range of control.

WELDING CAPABILITY(Duty Cycle)

The PRECISION TIG 185 is rated at 185 amps, 27 volts, at 15% duty cycle on a ten minute basis. It is capable of higher duty cycles at lower output currents. See rated output graph, on specification sheet located in the Installation Section. If the duty cycle is exceed-ed, a thermal protector will shut off the output until the machine cools.

PRECISION TIG 185



Return to Section TOC | Return to Master TOC

CONTROLS AND SETTINGS

All operator controls and adjustments are located on the front of the PRECISION TIG 185. Refer to Figure B.1 and corresponding explanations.

FIGURE B.1 - CONTROL PANEL

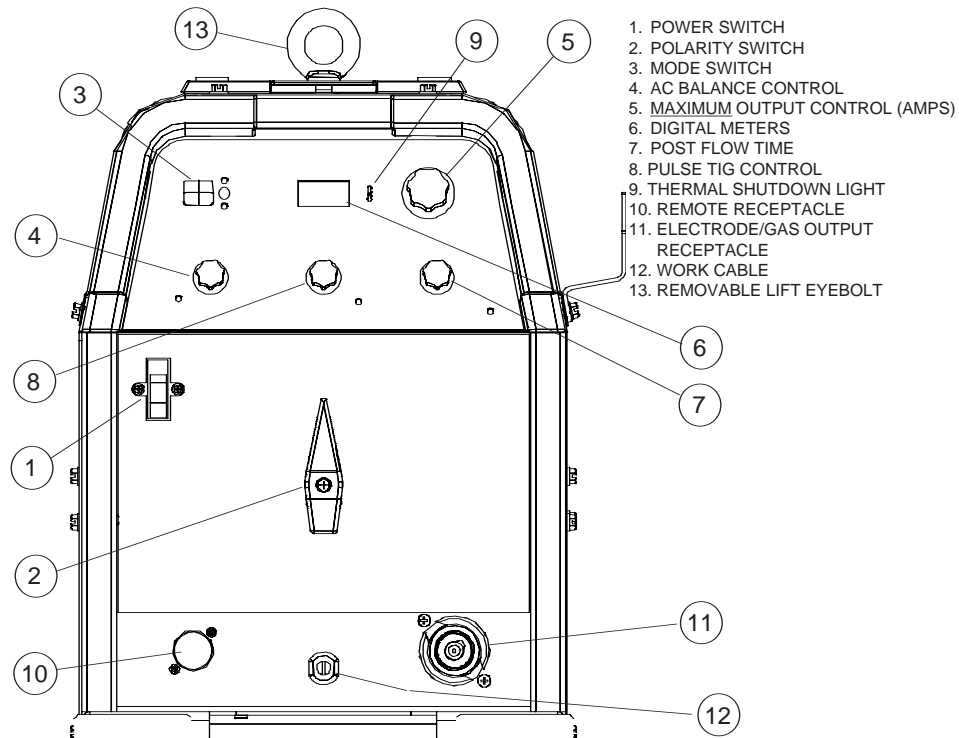

1. POWER SWITCH
2. POLARITY SWITCH
3. MODE SWITCH
4. AC BALANCE CONTROL
5. MAXIMUM OUTPUT CONTROL (AMPS)
6. DIGITAL METERS
7. POST FLOW TIME
8. PULSE TIG CONTROL
9. THERMAL SHUTDOWN LIGHT
10. REMOTE RECEPTACLE
11. ELECTRODE/GAS OUTPUT RECEPTACLE
12. WORK CABLE
13. REMOVABLE LIFT EYEBOLT

CONTROL FUNCTIONALITY

1. **POWER SWITCH** – Input line switch turns input power ON or OFF, as indicated by the on or off status of the front panel digital display (See Item 6).
2. **POLARITY SWITCH** – The rotary power switch has 3-positions for DC+, AC and DC- selections for the electrode output stud welding polarity.

CAUTION



- Do not switch the polarity switch while welding or damage may result to the machine.

3. **MODE SWITCH** – The push button switch allows selection of the two machine welding modes as indicated by colored mode lights:
 - STICK mode – Top position Red light.
 - TIG mode – Bottom position Green light.
4. **AC BALANCE CONTROL** – The AC Balance Control permits adjustment of the AC TIG wave balance adjustment from Max. Penetration (80% negative wave) at full CW rotation setting, to Max. Cleaning (60% positive wave) at CCW rotation, and includes:

- Auto Balance position indicated by the Green panel light turning on. This setting position feature automatically provides the proper amount of cleaning and penetration for normal AC TIG welding.

5. **MAXIMUM OUTPUT CONTROL** – Presets the output welding current over the rated output range of the machine:

- With a Remote Current Control (Amptrol) connected to the Remote Receptacle (See item 10), this knob sets the Maximum output current level set table with the remote Amptrol.
- For Pulse TIG (See Item 8) this knob sets the Peak Pulse level, with the Remote Amptrol (if used).

6. **DIGITAL METER** – A 3 digit LED meter is used to display the preset output current level before welding, and actual output level while welding:

- A lit display indicates input power is turned on. (See Item 1.)

7. **POST FLOW TIME** – Sets the TIG mode shielding gas post flow time over the range of about 1 to 30 seconds after the arc is shut off.

Note: Gas preflow time is fixed at 0.5 second only in TIG mode, but no preflow time will occur if the arc is restarted during Post Flow time, since shielding gas would not have stopped flowing.

PRECISION TIG 185



8. PULSE TIG CONTROL – The Pulse TIG feature built into the Precision TIG 185 is simplified to be a single knob control which sets the Pulse Frequency over the peak pulses/sec. range of about 0.1 to 20 pulses per second:

- Full CCW (min.) setting of the control knob shuts off Pulse TIG (0.0 pps).
- Peak Pulse level is set by the Max. Output Control and the Remote Amptrol (if used).
- Background Current level is typically optimized at a fixed 50% of Peak Pulse level setting.
- Peak Pulse % On-time is typically optimized at a fixed 50%.

A Green light "blinks" with each Peak Pulse to indicate the Pulse TIG Control setting before and during welding.

9. OVER TEMPERATURE LIGHT -  If the welder overheats due to blocked air flow, high ambient air temperature, or exceeded duty cycle, an internal thermostat will open disabling the welding output and this yellow light will illuminate. The cooling fans will continue to run to cool the unit during this time. The light will go out when the unit cools and the thermostat resets. Once the light goes out, the machine will again become available to weld.

10. REMOTE RECEPTACLE – Provides for connection of remote control and/or arc start switch only in TIG Mode: (There is no remote output control capability when stick welding.

- Plugging a remote current control (Amptrol) into this receptacle automatically switches the output control from the panel Max Output Control (See Item 5) to the remote control.
- The connected remote control will then control the output current between the Min. range of the machine and the setting of the panel Max Output Control.
- Switching Mode Switch (See Item 3) to Stick will automatically disable the connected remote control and switch the output control back to the Max Output panel control.

11. ELECTRODE/GAS OUTPUT RECEPTACLE - This quick connect Twist-Mate receptacle provides electrical connection to the electrode holder and cable for Stick welding and a combined electrical and gas connection for the TIG torch when TIG welding.

12. WORK CABLE - This work cable is factory connected to the welder and is connected to the work piece to complete the welding circuit. Refer to **Machine Grounding and High Frequency Interference Protection** in the Installation section of this manual for the proper procedure on grounding the work clamp and work piece to minimize high frequency interference.

OPERATING STEPS

WELDING IN TIG MODE

1. Connect the TIG torch and cable Twist-Mate quick connect plug to the Electrode/Gas output receptacle. This receptacle also contains an integral gas connection for the torch. Connect the work clamp to the work piece.
2. Set the TIG/STICK switch to "TIG".
3. Set the Polarity Switch to DC- for welding steel or stainless steel; or to AC for welding aluminum.
4. Connect the Foot Amptrol to the Remote Control Connector.
5. Turn on the cylinder gas valve and adjust the flow regulator to obtain desired flow.
6. Turn the power switch to "ON". **NOTE:** There will be a 15 second gas flow when the power is turned on.
7. Preset the Output Control on the control panel to the maximum desired amps, as read on the digital meter.
8. Depress the Foot Amptrol to energize the torch and establish an an arc with the work piece. The digital meter reads the actual amps while welding.

NOTE: When the TIG/STICK switch is set to "TIG", depressing the remote control will start a 0.5 second gas pre-flow before energizing the TIG torch. When the remote control is released the TIG torch is de-energized and gas flow will continue for the time set by the Post Flow Time control. When the polarity switch is set to DC, the TIG Arc Starter will turn on and off automatically to start and stabilize the arc. In AC the TIG Arc Starter will turn on with the output and remain on continuously until the remote control is released.

PULSE TIG CONTROL

Use this knob to set the frequency or the number of pulses per second(pps), from 0.1pps to 20pps.

- This setting adjusts heat output and bead shape for travel speed. Thinner plate that is welded with faster travel speed will require higher frequency than thicker plate with slower travel speed. 2-3pps is a typical starting point.

PRECISION TIG 185



REMOTE CONTROL OPERATION

A Foot Amptrol™ is included with the PRECISION TIG 185 Ready-Pak models and available for other models (See Accessories Section) for remote current control while TIG welding. An optional Hand Amptrol may also be used. An optional Arc Start Switch may be used to start and stop the welding if no remote control of the current is desired. Refer to the Accessories Section of this manual.

Both the Hand and Foot Amptrol work in a similar manner. For simplicity, the following explanation will refer only to "Amptrols", meaning both Foot and Hand models. The term "minimum" refers to a foot pedal in the "up" position, as it would be with no foot pressure, or a Hand Amptrol in the relaxed position, with no thumb pressure.

"Maximum" refers to a fully depressed Foot Amptrol, or a fully extended Hand Amptrol.

When the welder is in TIG modes activating the Amptrol energizes the electrode terminal and varies the output welding current from its minimum value of 5 Amp (DC) or 7 Amp (AC), to the maximum value set by the Current Control on the control panel. This helps eliminate accidental high current damage to the work piece and/or tungsten, and provides a fine control of the current. When the welder is in the stick mode a remote control has no effect and is not used.

It is important to note that, in some cases, the tungsten will not start an arc at the minimum current because the tungsten may be too large or cold. To start an arc reliably, it is important to depress the Amptrol far enough so that the machine output current is near the tungsten operating range. For example, a 3/32" tungsten may be used on DC- to weld over the full range of the machine.

To start the arc, the operator may have to turn the current control up and depress the Amptrol approximately 1/4 of the way down. Depressing the Amptrol to its minimum position may not start the arc. Also if the current control is set too low, the arc may not start. In most cases, a large or cold tungsten will not readily establish an arc at low currents. This is normal. In Direct Current mode the PRECISION TIG 185 will start a 3/32", 2% thoriated tungsten electrode at 15 amperes provided the electrode tip is properly grounded and not contaminated.

BENEFITS OF THE PRECISION TIG 185 DESIGN

In AC TIG welding of aluminum, the positive portion of the AC wave provides cleaning (removal of aluminum oxide) of the work piece. This is desirable on materials with a heavy oxide coating. However the positive portion may also cause the electrode to overheat at high currents causing "tungsten spitting". The negative portion of the AC wave offers no cleaning action but concentrates more heat on the work.

The AC waveform of the PRECISION TIG 185 optimizes cleaning and heating of the work. The result is the capability to weld through the complete range in AC TIG or DC- TIG requiring only one electrode, a 3/32" 2% thoriated tungsten.

WELDING IN STICK MODE

1. Put the electrode holder and cable quick connect plug into the electrode output receptacle. Turn clockwise until tight. Connect the work clamp to the work piece.
2. Set the TIG/STICK switch to "STICK".
3. Set the Polarity Switch to the weld mode desired for the type of electrode being used (most commonly DC+).
4. Place the electrode in the electrode holder.

5. Turn the power switch to "ON".
6. Adjust the Current Control to the desired amps.
7. Strike an arc and weld.

NOTE: When the TIG/STICK switch is set to "STICK" the output is always on when the power switch is on. A remote control has no effect on the welding current and the gas flow and high frequency TIG arc starter are disabled.

⚠ WARNING



• In Stick Mode the output terminal and electrode will be electrically hot whenever the power switch is turned on.

RECOMMENDED ELECTRODE AMPERAGE RANGES - PRECISION TIG 185

The PRECISION TIG 185 is rated from 5-185 Amps.

SMAW Process

ELECTRODE TYPE	POLARITY	Welding Amp Range for Stick Electrode Size		
		3/32"	1/8"	5/32"
Fleetweld 5P, Fleetweld 5P+ E6010	DC+	40 - 70	75 - 130	90 - 175
Fleetweld 180 E6011	DC+	40 - 80	55 - 110	105 - 135
Fleetweld 37 E6013	DC+	70 - 95	100 - 135	145 - 180
Fleetweld 47 E7014	DC-	75 - 95	100 - 145	135 - 200
Excalibur E7018	DC+	85 - 110	110 - 160	130 - 200
Blue Max Stainless	DC+	40 - 80	75 - 110	95 - 150
Red Baron Stainless	DC+	40 - 70	60 - 100	90 - 140

Mild steel procedures are based on recommended procedures listed in C2.10 8/94 and the maximum rating of the PRECISION TIG 185
 Blue Max procedures are based on C6.1 6/95
 Red Baron Procedure are based on ES-503 10/93

GTAW Process

Electrode Polarity	DC-	AC		Approximate Argon Gas Flow Rate C.F.H. (l/min.)			
		Balled		EWZr		Stainless Steel	
Electrode Tip Preparation	Sharpened						
Electrode Type	EWTh-1, EWCe-2 EWTh-2, EWLa-1	EWP	EWTh-1, EWTh-2 EWCe-2, EWLa-1	Aluminum		Stainless Steel	
Tungsten Size (in.)	EWG		EWG				
.010	Up to 15 A.	Up to 10 A.	Up to 15 A.	3-8	(2-4)	3-8	(2-4)
.020	Up to 15 A.	Up to 15 A.	Up to 20 A.	5-10	(3-5)	5-10	(3-5)
.040	Up to 80 A.	Up to 40 A.	Up to 60 A.	5-10	(3-5)	5-10	(3-5)
1/16	Up to 150 A.	Up to 100 A.	Up to 130 A.	5-10	(3-5)	9-13	(4-6)
3/32	Up to MAX. A.	Up to 160 A.	Up to MAX. A.	13-17	(6-8)	11-15	(5-7)
1/8	X	Up to MAX. A.	X	15-23	(7-11)	11-15	(5-7)

Tungsten electrodes are classified as follows by the American Welding Society (AWS):
 PureEWPgreen
 +1% ThoriumEWTh-1yellow
 +2% ThoriumEWTh-2red
 +2% CeriumEWCe-2orange
 +1.5% LanthanaEWLa-1black
 +0.15 to 0.40% ZirconiaEWZrbrown
 TRI-MIX OF ELEMENTSEWGgray

Ceriated Tungsten is now widely accepted as a substitute for 2% Thoriated Tungsten in AC and DC applications.

PRECISION TIG 185



Return to Section TOC
Return to Master TOC

Return to Section TOC
Return to Master TOC

Return to Section TOC
Return to Master TOC

Return to Section TOC
Return to Master TOC

Return to Section TOC
Return to Master TOC

PRECISION TIG 185



TABLE OF CONTENTS - ACCESSORIES SECTION -

AccessoriesSection C

Options / AccessoriesC-2/C-3

Return to Master TOC

Return to Master TOC

Return to Master TOC

Return to Master TOC

PRECISION TIG 185



FACTORY INSTALLED OPTIONS

The Precision TIG 185 will be available in two Factory-Configured Welding Packages:

1. Precision TIG 185 Ready-Pak (K2347-1)

- 208/230/1/60 Machine (K2345-1)
- 9 ft. (2.7m) Input Cable with NEMA 6-50P Plug*
- NEMA 6-50R Receptacle
- Integrated 10 ft.(3.1m)Work Lead w/Clamp*
- Gas Regulator with 10 ft.(3.1m). Hose
- PTA-17 12.5”(318mm) Ultra=Flex Torch with 3/32”(2.4mm)Electrode and Parts
- Foot Amptrol (K870)
- TIG Slide Rule (WC332)*
- GTAW Book (JFLF-834)*
- Lift Eyebolt*

2. Precision TIG 185 Ready-Pak w/Cart (K2347-2)

- 208/230/1/60 Machine (K2345-1)
- 9 ft.(2.7m) Input Cable with NEMA 6-50P Plug*
- NEMA 6-50R Receptacle
- Integrated 10 ft.(3.1m) Work Lead w/Clamp*
- Gas Regulator with 10 ft.(3.1m) Hose
- PTA-17 12.5 ft.(3.8m) One cable Superflex Torch with 3/32”(2.4mm) Electrode and Parts
- Foot Amptrol (K870)
- TIG Slide Rule (WC332)*
- GTAW Book (JFLF-834)*
- Lift Eyebolt*
- Under-Storage Cart (K2348-1)

* Included with K2345-1 Machine Only model.

The Precision TIG 185 will also be available as Basic models with Domestic input voltages for user-configuration with optional accessories: (See Table C.1)

TABLE C.1

Select Machine	208/230/1/60 Machine with 9 ft.(2.7m) NEMA 6-50P Plug Cable and Receptacle (K2345-1) 460/575/1/60 Machine only with Cable (K2345-2) 380/400-415/1/50-60 Machine only with Cable (K2346-1)	
Optional Torch Starter Kit (Select one)	Water Cooled System	Air Cooled System
	K2267-1 TIG-Mate 20 Torch Starter Kit Includes: • 200A PTW-20 12.5 ft.(3.81m) Torch • KP510 Parts Kit • Regulator & Hose • K1622-4 Twist Mate Torch Adapter • Water Hose & Hose Coupler • Work Cable & Clamp (Not required for Precision TIG 185)	K2266-1 TIG-Mate Torch Starter Kit Includes: • 150A PTA-17 12.5 ft.(3.81m) Torch. • KP508 Parts Kit. • Regulator & Hose. • K1622-1 Twist Mate Torch Adapter. • Work Cable & Clamp (Not required for Precision TIG 185)
Water Cooler	Not Applicable	K1813-1 115V 50/60Hz Cool-Arc 40
Optional Under-Storage Cart	K2348-1	
Optional Remote Trigger Device (Select one)	K814 Arc Start Switch K870 Foot Amptrol K870-1 Start Pedal Foot Amptrol K963-3 Hand Amptrol	

PRECISION TIG 185



Return to Section TOC

Return to Section TOC

Return to Section TOC

Return to Section TOC

Return to Master TOC

Return to Master TOC

Return to Master TOC

Return to Master TOC

FIELD INSTALLED OPTIONS

The following Options/Accessories are available for the Precision TIG 185:

- **K2348-1 Under-Storage Cart**
Includes a front magnetic latch storage drawer and rear storage bin on a single bottle undercarriage. (L12225 Installation Instructions included)
- **K870 Foot Amptrol**
Single pedal foot activation of arc start switch and output control, with 25 ft.(7.6m) plug cable.
- **K870-1 Start Pedal Foot Amptrol**
Independent start pedal on control pedal provides two-stage foot action to easily feel start switch closure at minimum output level for enhanced arc start and crater-fill control. Provided with adjustable, or removable, heel stop and 25 ft.(7.6m) plug cable.
- **K963-3 Hand Amptrol**
Fastens to torch for convenient thumb activation of arc start switch and output control, with 25 ft.(7.6m) plug cable:
- **K814 Arc Start Switch**
Needed for TIG welding without an Amptrol. Includes 25 ft.(7.6m) plug cable, and attaches to torch for convenient finger control.
- **TIG-Mate Torch Starter Kits:**
Includes Torch with Twist-Mate adapter and accessories listed below:
 - K2266-1 TIG-Mate Torch Starter Kit** Includes:
 - 150A PTA-17 12.5 ft.(3.8m) Torch
 - KP508 Parts Kit
 - Regulator & Hose
 - K1622-1 Twist Mate Torch Adapter
 - Work Cable & Clamp (Not required for Precision TIG 185)
 - K2267-1 TIG-Mate 20 Torch Starter Kit** Includes:
 - 200A PTW-20 12.5 ft.(3.8m) Torch
 - KP510 Parts Kit
 - Regulator & Hose
 - K1622-4 Twist Mate Torch Adapter
 - Water Hose & Hose Coupler
 - Work Cable & Clamp
(Not required for Precision TIG 185)
- **Magnum “Pro-Torch™ TIG Torch”** assemblies and Accessories.
Requires Twist-Mate Adapter:
K1622-1 for PTA-9/-17
K1622-3 for PTA-26
K1622-4 for PTW water cooled torch
- **Harris #3100211 Harris Argon Flow Regulator**
(Includes 10 ft.(3.1m) hose.)
- **K2374-1 Electrode Holder and Cable**
200 amp Electrode Holder with 10 ft.(3.1m) cable and Twist-Mate connector.

PRECISION TIG 185



Return to Section TOC
Return to Master TOC

Return to Section TOC
Return to Master TOC

Return to Section TOC
Return to Master TOC

Return to Section TOC
Return to Master TOC

PRECISION TIG 185



TABLE OF CONTENTS - MAINTENANCE SECTION -

MaintenanceSection D

Safety PrecautionsD-2

Routine Maintenance.....D-2

Periodic Maintenance.....D-2

Spark Gap AdjustmentD-2

Fan Motor and Blade ReplacementD-2

Major Component Locations.....D-3

Return to Master TOC

Return to Master TOC

Return to Master TOC

Return to Master TOC

SAFETY PRECAUTIONS

⚠ WARNING



ELECTRIC SHOCK can kill.

- Only qualified personnel should perform this maintenance.
- Turn the input power OFF at the disconnect switch or fuse box before working on this equipment.
- Do not touch electrically hot parts.

⚠ WARNING

To avoid receiving a high frequency shock, keep the TIG torch and cables in good condition.

ROUTINE AND PERIODIC MAINTENANCE

1. Disconnect power supply lines to machine before performing periodic maintenance.
2. Periodically clean the inside of the machine with a low pressure air system. Be sure to clean the following components thoroughly.
 - Main Transformer
 - Electrode/Gas Output Receptacle
 - Polarity Switch
 - Rectifier Assembly
 - Arc Starter/Spark Gap Assembly
 - PC Boards
 - Fan Blades
3. Inspect welder output and control cables for fraying, cuts, and bare spots.
4. Keep TIG torch and cables in good condition.
5. Clean air louvers to ensure proper air flow and cooling.
6. The fan motor has sealed ball bearings which require no maintenance.
7. **SPARK GAP ADJUSTMENT**

The spark gap is set at the factory to a gap of 0.020. See Figure D.1. This setting is adequate for most applications. Where less high frequency is desired, the setting can be reduced to 0.015 inches (0.4mm).

⚠ WARNING

Use extreme caution when working with circuit of the high frequency. The high voltages developed can be lethal. Turn the input power off using the disconnect switch or fuse box before working inside machine. This is particularly important when working on the secondary circuit of the high voltage transformer (T3) because the output voltage is dangerously high.

Refer to figure D.1. Note in highly dirty environments where there is an abundance of conductive contaminants, use a low pressure air stream or a firm piece of paper to clean the spark gap. Do not disturb the factory setting.

To check the spark gap:

- Turn off input power as specified above.
- Remove the right side panel from the machine, the spark gap box is located on the lower right side.
- Check the spark gap with a feeler gauge.

If adjustment is needed:

- Adjust the gap by loosening the allen head screw in one of the aluminum blocks, near the front of the unit and tighten the screw in the new position.

If the gap is correct:

- Replace the wraparound.

8. Inspect gas hose and inlet fitting for cracks or leaks.
9. Replace any unreadable labels or decals.
10. Verify that the machine and welding circuit is properly grounded.

FIGURE D.1 SPARK GAP

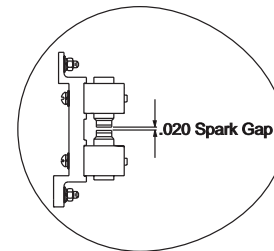

FAN MOTOR OR FAN BLADE REPLACEMENT

When installing a new fan blade or fan motor be sure to maintain proper shaft spacing per Figure D.2 below.

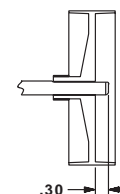

FIGURE D.2

PRECISION TIG 185



FIGURE D.2 — LOCATION OF MAINTENANCE COMPONENTS.

- 1. Case Front Assembly
- 2. Case Back Assembly
- 3. Arc Starter & Bypass Assembly
- 4. Center Assembly
- 5. Cover Assembly
- 6. Cart Base Assembly
- 7. Upper Cylinder Support Assembly
- 8. TIG Torch & Cable Assembly
- 9. Foot Amptrol Assembly (Pedal)

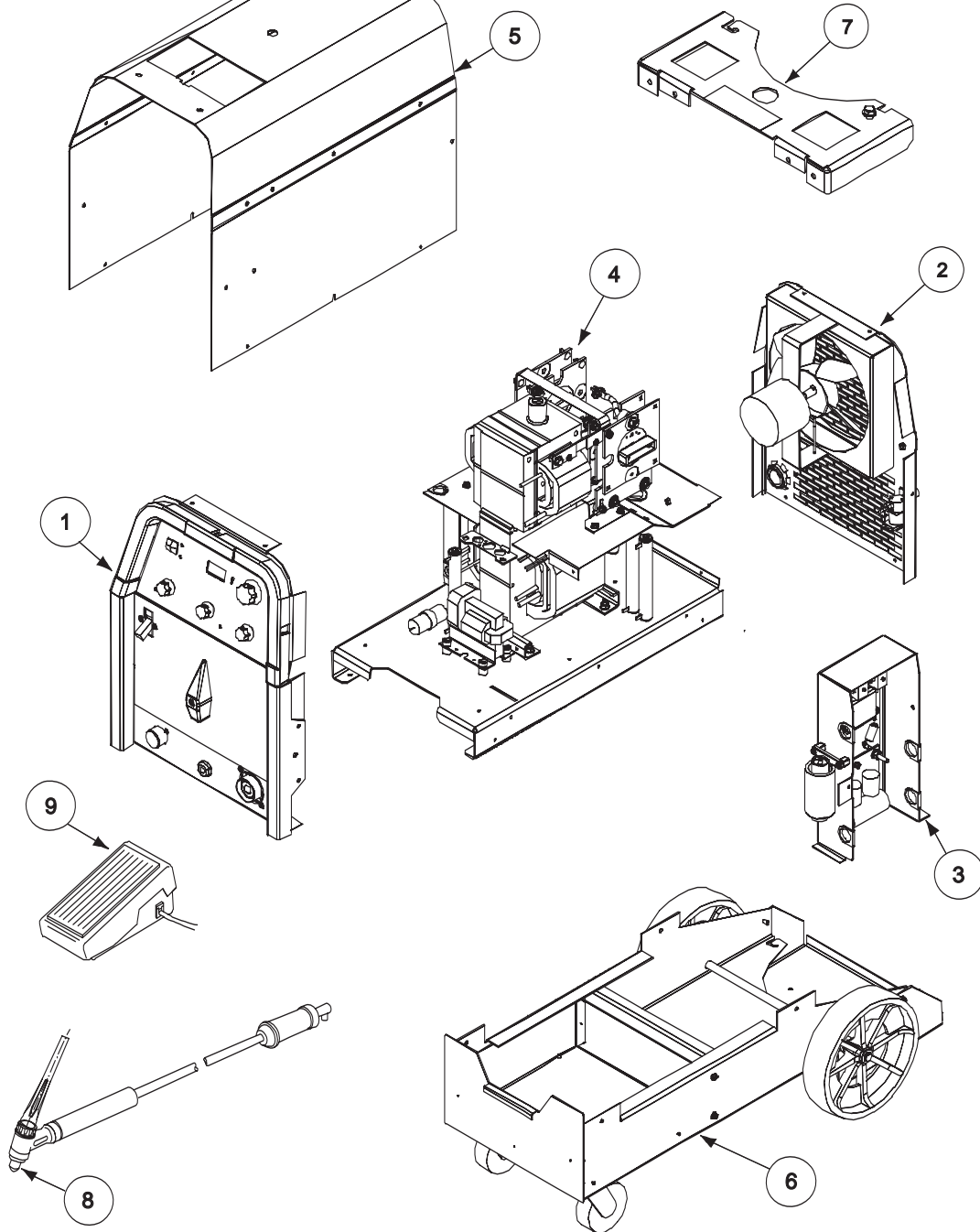

PRECISION TIG 185



Return to Section TOC

Return to Section TOC

Return to Section TOC

Return to Section TOC

Return to Master TOC

Return to Master TOC

Return to Master TOC

Return to Master TOC

Return to Section TOC
Return to Master TOC

Return to Section TOC
Return to Master TOC

Return to Section TOC
Return to Master TOC

Return to Section TOC
Return to Master TOC

PRECISION TIG 185



TABLE OF CONTENTS - THEORY OF OPERATION SECTION -

Return to Master TOC

Return to Master TOC

Return to Master TOC

Return to Master TOC

Theory of OperationSection E

General DescriptionE-2

Input Power CircuitE-2

Output Rectification and Feedback ControlE-3

High Voltage/High Frequency CircuitE-4

DC Welding OutputE-5

AC Welding OutputE-6

SCR OperationE-7

Protective CircuitsE-8

Thermal ProtectionE-8

Overload ProtectionE-8

FIGURE E.1 – PRECISION TIG 185 BLOCK LOGIC DIAGRAM

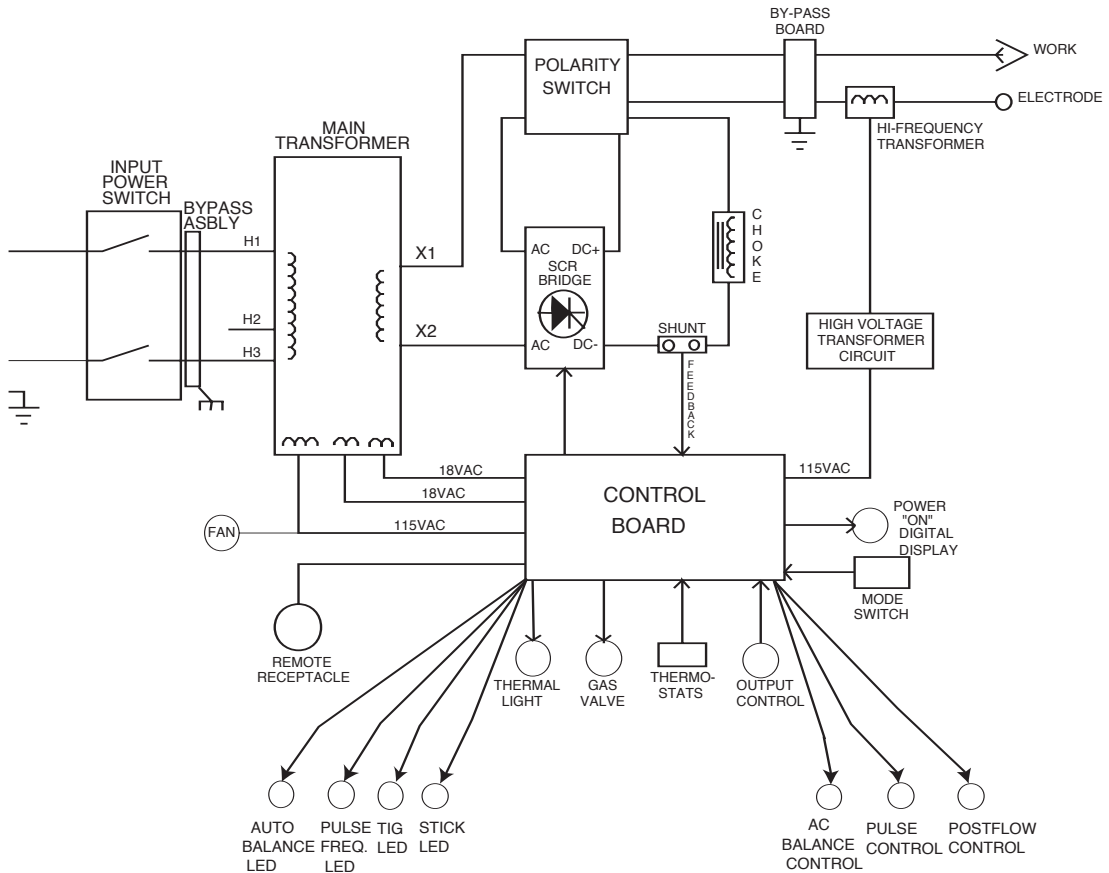

PRECISION TIG 185



GENERAL DESCRIPTION

The PRECISION TIG 185 is a member of our field acclaimed Precision TIG family of industrial arc welding power sources. Premium features include:

1. Precise constant current output.
2. Full range square wave AC/DC TIG (GTAW) welding.

3. Enhanced version of the patented MicroStart™ Technology for its lower Minimum (5amps) to higher Maximum (185 amps) output control range.
4. Built-in high frequency stabilization for DC TIG starting and continuous AC TIG welding.
5. AC/DC Stick (SMAW capability.)

FIGURE E.2 Main Transformer and Input Power

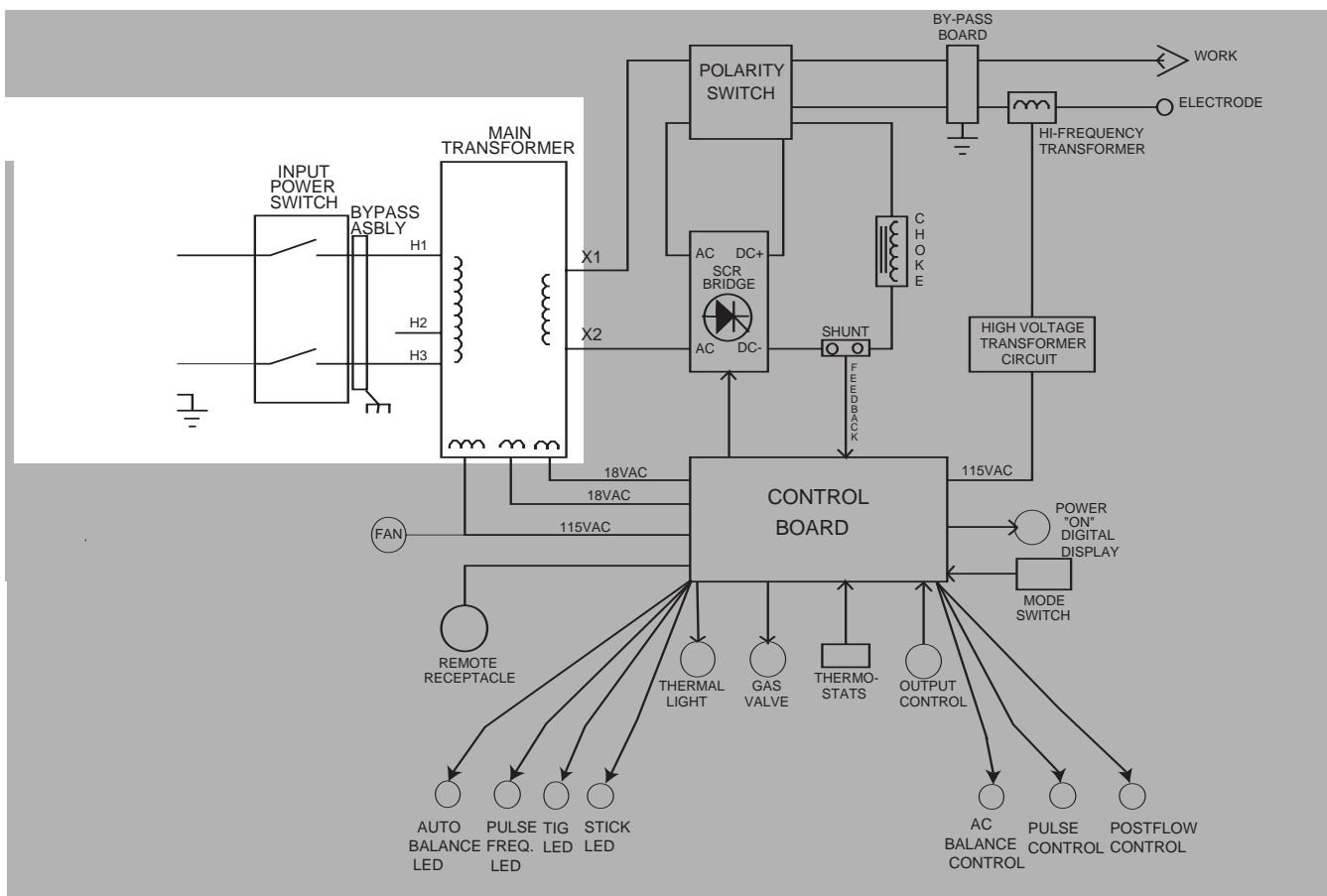

INPUT POWER CIRCUIT

The desired single-phase input power is connected to the TIG 185 through an input power switch located in the front panel of the machine. The machine can be configured for either 230VAC or 208VAC input voltage by connecting the appropriate lead (H2 or H3) to the input power switch. When the input power switch is turned "ON" the input voltage is applied directly to the primary of the main transformer.

The main transformer changes the high voltage, low current input power to a low voltage, high current output which is available at the main secondary winding (X1 and X2). In addition three auxiliary windings are

incorporated in the main transformer. The 115VAC winding supplies power to the fan motor and also, through the control board, powers the gas solenoid valve and the high voltage transformer. The 18VAC winding provides power to the trigger circuitry. The other 18VAC winding is rectified and regulated to a 15VDC supply which operates the circuitry on the control board.

NOTE: Unshaded areas of block logic diagrams are the subject of discussion.

PRECISION TIG 185



FIGURE E.3 Control Board and Output Feedback Control.

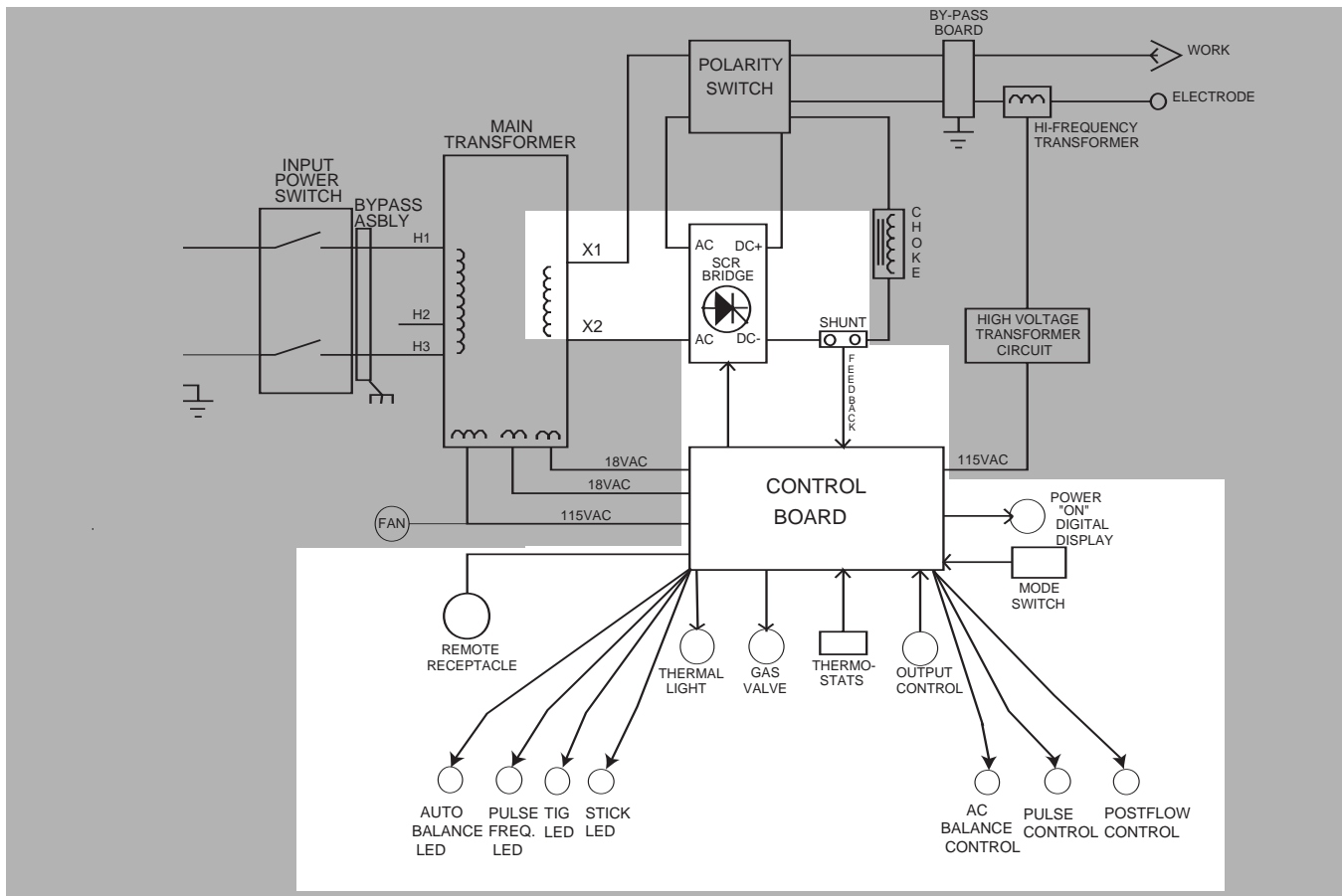

OUTPUT RECTIFICATION AND FEEDBACK CONTROL

The AC output from the main transformer secondary is rectified and controlled through the SCR bridge. Output current is sensed at the shunt as a low voltage signal and fed back to the control board. The control board compares the commands of the mode switch, output control, AC balance control, pulse control, post-flow control, or remote control with the feedback information. The appropriate SCR gate firing signals are created by the control board and sent to the SCR bridge. The control board controls the firing of the SCRs, which control the output of the machine. See **SCR Operation**. The control board monitors the thermostats, and also controls the gas solenoid valve, thermal light, auto balance LED, pulse frequency LED, TIG LED, stick LED, and the digital display.

NOTE: Unshaded areas of block logic diagrams are the subject of discussion.

PRECISION TIG 185



FIGURE E.4 High Voltage/High Frequency Circuit.

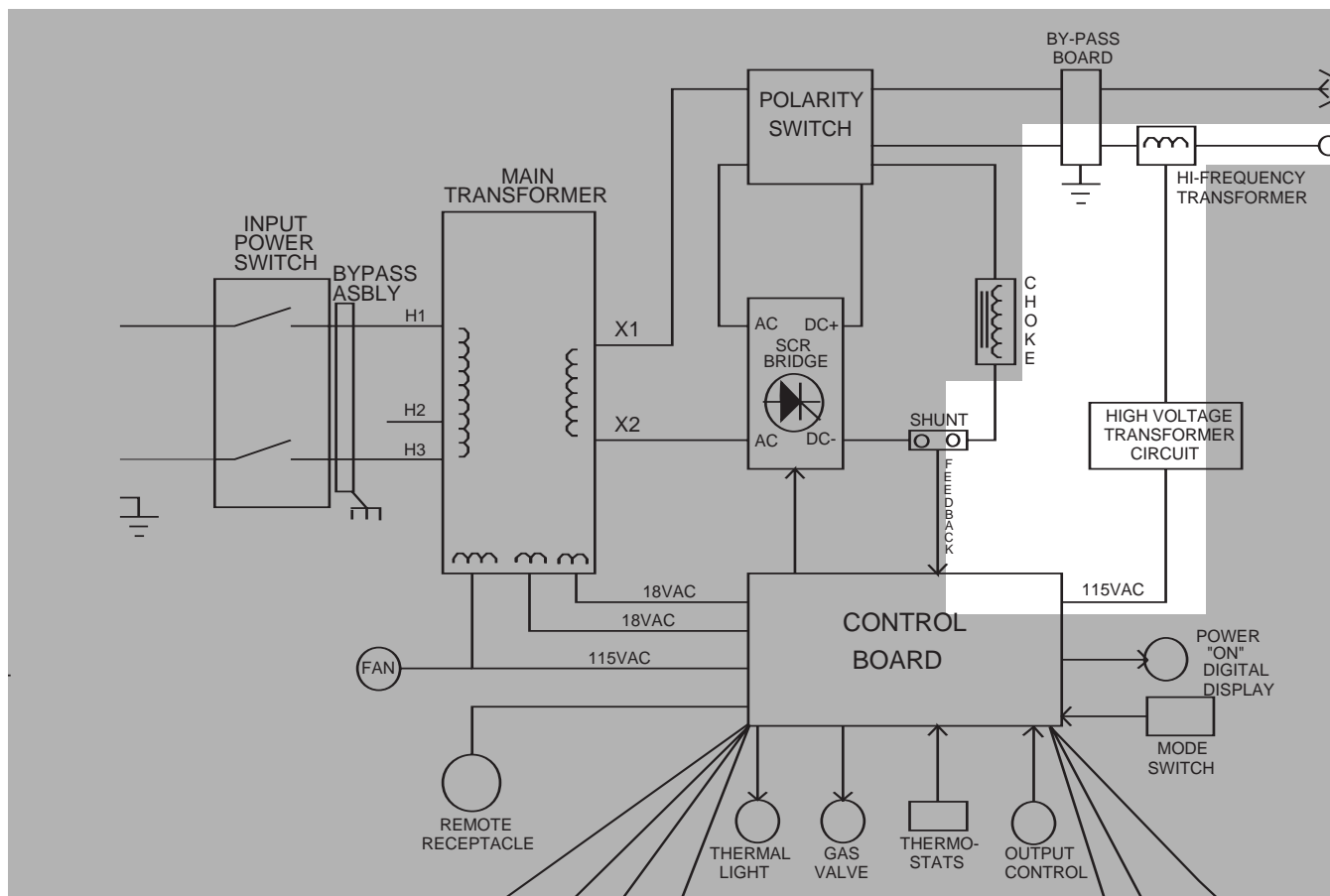

HIGH VOLTAGE / HIGH FREQUENCY CIRCUIT

The control board passes the 115VAC voltage to the primary of the high voltage transformer. The secondary of the high voltage transformer is coupled to a spark gap generator and also to the high frequency transformer. The high frequency transformer transfers the high frequency "spark" to the electrode terminal which is coupled to the TIG torch.

NOTE: Unshaded areas of block logic diagrams are the subject of discussion.

PRECISION TIG 185



DC WELDING OUTPUT

When the polarity switch is placed in either DC position, the AC voltage from the main transformer secondary is applied to the SCR bridge. The SCR bridge and choke circuits are connected in a conventional full wave bridge and filter configuration, resulting in a controlled DC output. Since the choke is in series with the negative leg of the bridge and also in series with the welding load, a filtered DC is applied to the machine output terminals.

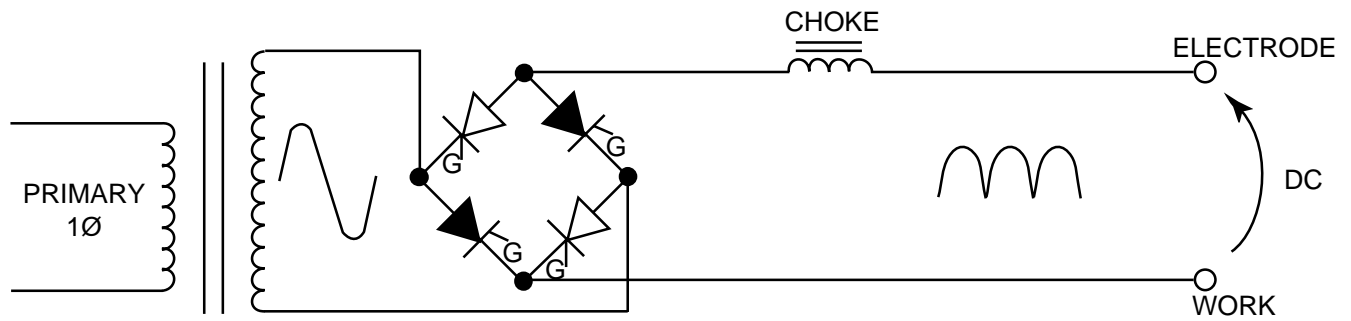

FIGURE E.5 DC Welding Current Generation.

Return to Section TOC
Return to Master TOC

Return to Section TOC
Return to Master TOC

Return to Section TOC
Return to Master TOC

Return to Section TOC
Return to Master TOC

AC WELDING OUTPUT

Rotating the polarity switch to the AC position changes the welding power circuit. One lead (X1) of the main transformer secondary is connected to the machine output work terminal. The other secondary lead (X2) is connected to one of the AC connections on the SCR bridge. The electrode terminal is connected to the other AC side of the bridge. The choke is now electrically across the negative and positive SCR bridge connections. With the ability of the choke to store energy and the SCRs to turn on at the appropriate times, an AC square wave is developed and applied to the output terminals.

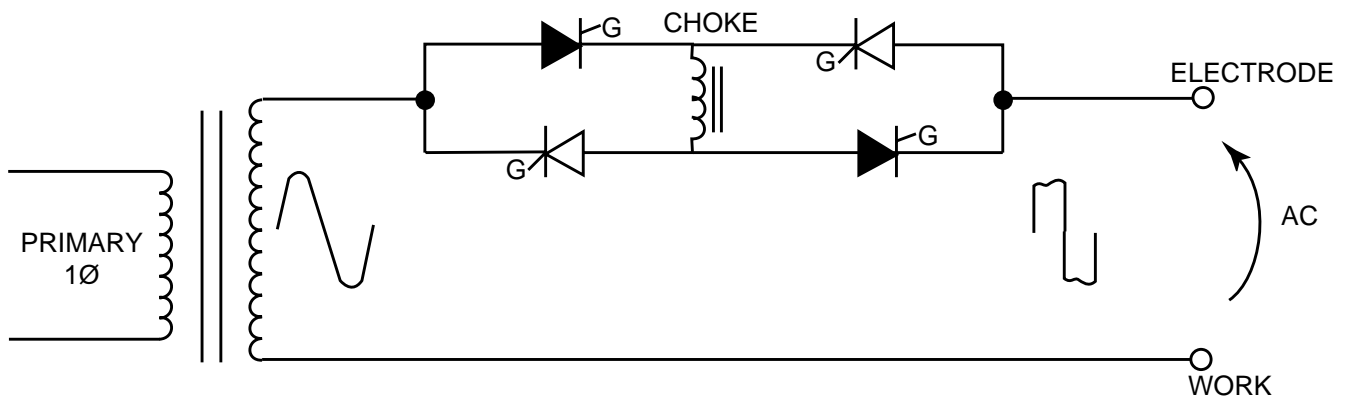

FIGURE E.6 AC Square Wave Welding Current Generation.

SCR OPERATION

A silicon controlled rectifier (SCR) is a three terminal device used to control rather large currents to a load. An SCR acts very much like a switch. When a gate signal is applied to the SCR it is turned ON and there is current flow from anode to cathode. In the ON state the SCR acts like a closed switch. When the SCR is turned OFF there is no current flow from anode to cathode thus the device acts like an open switch. As the name suggests, the SCR is a rectifier, so it passes current only during positive half cycles of the AC supply. The positive half cycle is the portion of the sine wave in which the anode of the SCR is more positive than the cathode.

between gate and cathode, the voltage between these terminals must be slightly greater than 0.6V. Once the SCR has fired it is not necessary to continue the flow of gate current. As long as current continues to flow from anode to cathode the SCR will remain on. When the anode to cathode current drops below a minimum value, called holding current, the SCR will shut off. This normally occurs as the AC supply voltage passes through zero into the negative portion of the sine wave. If the SCR is turned on early in the positive half cycle, the conduction time is longer resulting in greater SCR output. If the gate firing occurs later in the cycle the conduction time is less resulting in lower SCR output.

When an AC supply voltage is applied to the SCR, the device spends a certain portion of the AC cycle time in the on state and the remainder of the time in the off state. The amount of time spent in the ON state is controlled by the Gate.

An SCR is fired by a short burst of current into the gate. This gate pulse must be more positive than the cathode voltage. Since there is a standard PN junction

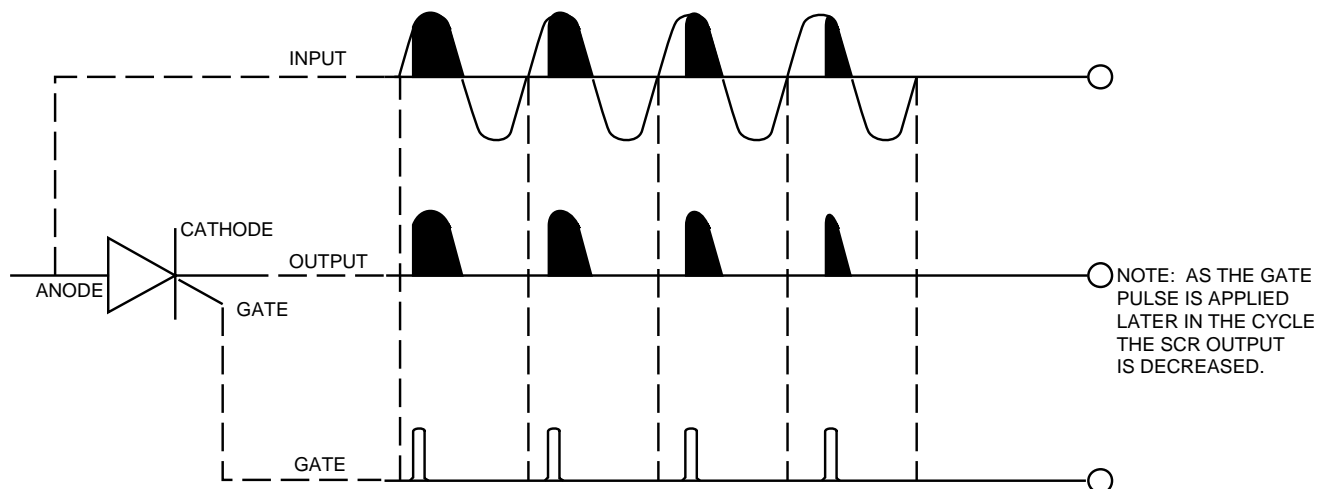

FIGURE E.7 SCR Operation

PRECISION TIG 185



PROTECTIVE CIRCUITS

Protective circuits are designed into the PRECISION TIG 185 to sense trouble and shut down the machine before the trouble damages the internal machine components. Both thermal protection and current overload are included. Fan as needed (F.A.N.) Fan runs for 5 seconds at power-up and stops at idle 8 minutes after welding.

THERMAL PROTECTION

9. OVER TEMPERATURE LIGHT-  If the welder overheats due to blocked air flow, high ambient air temperature, or exceeded duty cycle, an internal thermostat will open disabling the welding output and this yellow light will illuminate. The cooling fans will continue to run to cool the unit during this time. The light will go out when the unit cools and the thermostat resets. Once the light goes out, the machine will again become available to weld.

Once the machine cools sufficiently the thermostats are self-resetting. If the thermostat shutdown is caused

by excessive output or duty cycle and the fan is operating normally, the power may be left on, and the reset should occur within a 15 minute period. If the fan is not functioning properly or the air intake louvers are obstructed, then the input power must be removed and the fan problem or air obstruction corrected.

OVERLOAD PROTECTION

The machine is electronically protected from producing excessively high output currents. The output is limited to 200 amps.

Return to Section TOC

Return to Master TOC

Return to Section TOC

Return to Master TOC

Return to Section TOC

Return to Master TOC

Return to Section TOC

Return to Master TOC

PRECISION TIG 185



TABLE OF CONTENTS

- TROUBLESHOOTING & REPAIR SECTION -

Troubleshooting & Repair SectionSection F

How to Use Troubleshooting Guide.....	F-2
PC Board Troubleshooting Procedures and Replacement.....	F-3
Troubleshooting Guide.....	F-4
Test Procedures	
High Frequency Circuit Disable Procedure	F-15
T1 Transformer Test.....	F-17
Static SCR Test	F-21
Active SCR Test.....	F-25
Oscilloscope Waveforms	
Normal Open Circuit Voltage Waveform-AC TIG Mode.....	F-29
Normal Open Circuit Voltage Waveform-DC TIG Mode.....	F-30
Normal Open Circuit Voltage Waveform-AC Stick Mode.....	F-31
Normal Open Circuit Voltage Waveform-DC Stick Mode	F-32
Typical Output Voltage Waveform-Machine Loaded AC TIG Mode.....	F-33
Typical Output Voltage Waveform-Machine Loaded DC TIG Mode	F-34
Typical Output Voltage Waveform-Machine Loaded AC Stick Mode	F-35
Typical Output Voltage Waveform-Machine Loaded DC Stick Mode	F-36
Abnormal Open Circuit Voltage-DC TIG Mode One SCR not Functioning.....	F-37
Replacement Procedures	
SCR Bridge Assembly Removal and Replacement	F-39
Polarity Switch Removal and Replacement	F-45
High Voltage Transformer Removal and Replacement	F-49
Main Transformer and Output Choke Removal and Replacement	F-53
Retest after Repair	F-57

**CAUTION**

This Troubleshooting Guide is provided to help you locate and repair possible machine malfunctions. Simply follow the three-step procedure listed below.

Step 1. LOCATE PROBLEM (SYMPTOM). Look under the column labeled “PROBLEM (SYMPTOMS)”. This column describes possible symptoms that the machine may exhibit. Find the listing that best describes the symptom that the machine is exhibiting. Symptoms are grouped into three main categories: Feeding Problems and Welding Problems.

Step 2. PERFORM EXTERNAL TESTS. The second column, labeled “POSSIBLE AREAS OF MISADJUSTMENT(S)”, lists the obvious external possibilities that may contribute to the machine symptom. Perform these tests/checks in the order listed. In general, these tests can be conducted without removing the case wrap-around cover.

Step 3. PERFORM COMPONENT TESTS. The last column, labeled “Recommended Course of Action” lists the most likely components that may have failed in your machine. It also specifies the appropriate test procedure to verify that the subject component is either good or bad. If there are a number of possible components, check the components in the order listed to eliminate one possibility at a time until you locate the cause of your problem.

All of the referenced test procedures referred to in the Troubleshooting Guide are described in detail at the end of this chapter. Refer to the Troubleshooting and Repair Table of Contents to locate each specific Test Procedure. All of the referred to test points, components, terminal strips, etc., can be found on the referenced electrical wiring diagrams and schematics. Refer to the Electrical Diagrams Section Table of Contents to locate the appropriate diagram.

**WARNING**

HIGH VOLTAGE / HIGH FREQUENCY can damage test equipment.

- Perform all voltage and waveform checks with high frequency circuit OFF. Perform **High Frequency Disable Procedure**.

**CAUTION**

If for any reason you do not understand the test procedures or are unable to perform the test/repairs safely, contact the Lincoln Electric Service Department for electrical troubleshooting assistance before you proceed. Call 1-888-935-3877.

PRECISION TIG 185



PC BOARD TROUBLESHOOTING PROCEDURES

WARNING

**ELECTRIC SHOCK
can kill.**

- Have an electrician install and service this equipment. Turn the input power OFF at the fuse box before working on equipment. Do not touch electrically hot parts.

CAUTION

Sometimes machine failures appear to be due to PC board failures. These problems can sometimes be traced to poor electrical connections. To avoid problems when troubleshooting and replacing PC boards, please use the following procedure:

1. Determine to the best of your technical ability that the PC board is the most likely component causing the failure symptom.
2. Check for loose connections at the PC board to assure that the PC board is properly connected.
3. If the problem persists, replace the suspect PC board using standard practices to avoid static electrical damage and electrical shock. Read the warning inside the static resistant bag and perform the following procedures:

PC board can be damaged by static electricity.

- Remove your body's static charge before opening the static-shielding bag. Wear an anti-static wrist strap. For safety, use a 1 Meg ohm resistive cord connected to a grounded part of the equipment frame.

- If you don't have a wrist strap, touch an un-painted, grounded, part of the equipment frame. Keep touching the frame to prevent static build-up. Be sure not to touch any electrically live parts at the same time.

- Tools which come in contact with the PC board must be either conductive, anti-static or static-dissipative.

- Remove the PC board from the static-shielding bag and place it directly into the equipment. Don't set the PC board on or near paper, plastic or cloth which could have a static charge. If the PC board can't be installed immediately, put it back in the static-shielding bag.

- If the PC board uses protective shorting jumpers, don't remove them until installation is complete.

- If you return a PC board to The Lincoln Electric Company for credit, it must be in the static-shielding bag. This will prevent further damage and allow proper failure analysis.

4. Test the machine to determine if the failure symptom has been corrected by the replacement PC board.

NOTE: It is desirable to have a spare (known good) PC board available for PC board troubleshooting.

NOTE: Allow the machine to heat up so that all electrical components can reach their operating temperature.

5. Remove the replacement PC board and substitute it with the original PC board to recreate the original problem.

a. If the original problem does not reappear by substituting the original board, then the PC board was not the problem. Continue to look for bad connections in the control wiring harness, junction blocks, and terminal strips.

b. If the original problem is recreated by the substitution of the original board, then the PC board was the problem. Reinstall the replacement PC board and test the machine.

6. Always indicate that this procedure was followed when warranty reports are to be submitted.

NOTE: Following this procedure and writing on the warranty report, "INSTALLED AND SWITCHED PC BOARDS TO VERIFY PROBLEM," will help avoid denial of legitimate PC board warranty claims.

TROUBLESHOOTING GUIDE

Observe Safety Guidelines detailed in the beginning of this manual.

PROBLEMS (SYMPTOMS)	POSSIBLE AREAS OF MISADJUSTMENT(S)	RECOMMENDED COURSE OF ACTION
OUTPUT PROBLEMS		
Machine is dead. No output - No fan	<ol style="list-style-type: none"> 1. Make sure that the input power switch is in the "ON" position and the machine is plugged in. 2. Check the input voltage at the machine. Input voltage must match the rating plate and voltage connection. Refer to Reconnect Procedure in the Installation section of this manual. 3. Blown or missing fuses in the input line. 	<ol style="list-style-type: none"> 1. Check the input power switch and associated wires for loose or faulty connections. 2. Perform the T1 Transformer Test.
The fan runs normally. No output from the machine in either Stick or TIG modes.	<ol style="list-style-type: none"> 1. Check for proper input voltages per nameplate and voltage reconnect configuration. 2. Check to make sure the polarity switch is in the proper position and functioning correctly. 	<ol style="list-style-type: none"> 1. Check for loose or faulty connections on the heavy current carrying leads. (polarity switch, output choke output terminals etc.) 2. Perform the T1 Transformer Test. 3. Perform the SCR Bridge Test. 4. Check current control R1 for proper operation. Normal resistance is 10,000 ohms. Also check associated leads for loose or faulty connections. 5. The control board may be faulty. Replace.

**CAUTION**

If for any reason you do not understand the test procedures or are unable to perform the test/repairs safely, contact the Lincoln Electric Service Department for electrical troubleshooting assistance before you proceed. Call 1-888-935-3877.

PRECISION TIG 185



TROUBLESHOOTING GUIDE

Observe Safety Guidelines detailed in the beginning of this manual.

PROBLEMS (SYMPTOMS)	POSSIBLE AREAS OF MISADJUSTMENT(S)	RECOMMENDED COURSE OF ACTION
OUTPUT PROBLEMS		
<p>Fan runs - No output from machine in either Stick or TIG modes and the yellow light on the control panel is on.</p>	<ol style="list-style-type: none"> The welding application may have exceeded the recommended duty cycle. Allow the unit to run until the fan cools the unit and the yellow light goes out. The air louvers may be blocked. Remove air obstruction and allow unit to cool. 	<ol style="list-style-type: none"> One of the thermostats may be faulty. Check or replace. See wiring diagram. Check for loose or faulty wires on the thermostats and associated circuitry. See wiring diagram.
<p>The machine does not respond (no gas flow, no high frequency and no open circuit voltage) when the arc start switch or Amptrol is activated - fan is working normally.</p>	<ol style="list-style-type: none"> Make certain the machine is in the TIG mode. The Amptrol may be defective. Check for continuity (zero ohms) between pins "D" and "E" on cable connector when the Amptrol is depressed. 	<ol style="list-style-type: none"> Check the continuity (zero ohms) of the leads between the remote receptacle and plug J5 on the control board. See wiring diagram. Perform the T1 Transformer Test. The control board may be faulty. Replace.



CAUTION

If for any reason you do not understand the test procedures or are unable to perform the test/repairs safely, contact the Lincoln Electric Service Department for electrical troubleshooting assistance before you proceed. Call 1-888-935-3877.

PRECISION TIG 185



Return to Section TOC

Return to Section TOC

Return to Section TOC

Return to Section TOC

Return to Master TOC

Return to Master TOC

Return to Master TOC

Return to Master TOC

TROUBLESHOOTING GUIDE

Observe Safety Guidelines detailed in the beginning of this manual.

PROBLEMS (SYMPTOMS)	POSSIBLE AREAS OF MISADJUSTMENT(S)	RECOMMENDED COURSE OF ACTION
OUTPUT PROBLEMS		
<p>Machine regularly over heats - thermostat opens. Yellow light on front panel glows. The fan runs but the machine has no output.</p>	<p>Machine regularly over heats - thermostat opens. Yellow light on front panel glows. The fan runs but the machine has no output.</p>	<ol style="list-style-type: none"> 1. The thermostat(s) may be faulty. Check or replace. 2. The control board may be faulty.
<p>The machine does not have output in the Stick mode. The machine operates correctly in the TIG mode.</p>	<p>The machine does not have output in the Stick mode. The machine operates correctly in the TIG mode.</p>	<ol style="list-style-type: none"> 1. Check the Stick/TIG switch(S3) and associated leads. See wiring diagram. 2. The control board may be faulty.

 **CAUTION**

If for any reason you do not understand the test procedures or are unable to perform the test/repairs safely, contact the Lincoln Electric Service Department for electrical troubleshooting assistance before you proceed. Call 1-888-935-3877.

PRECISION TIG 185



Return to Section TOC

Return to Master TOC

TROUBLESHOOTING GUIDE

Observe Safety Guidelines detailed in the beginning of this manual.

PROBLEMS (SYMPTOMS)	POSSIBLE AREAS OF MISADJUSTMENT(S)	RECOMMENDED COURSE OF ACTION
OUTPUT PROBLEMS		
<p>Machine welds at a very low output regardless of the current control setting.</p>	<ol style="list-style-type: none"> 1. If welding in the TIG mode the remote control device may be defective. 2. Make certain the input line voltage is correct for the machine reconnect configuration. 3. Check the welding cables and or torch for loose or faulty connections. 	<ol style="list-style-type: none"> 1. Check the polarity switch and associated leads. 2. Check the interior connections of the heavy current carrying leads. 3. Perform the SCR Bridge Test. 4. Perform the T1 Transformer Test. 5. Check the current control for proper operation. Normal resistance is 10k ohms. See wiring diagram. 6. The control board may be faulty.
<p>The machine welds at a very high output regardless of the current control setting.</p>	<ol style="list-style-type: none"> 1. If welding in the TIG mode the remote control device may be defective. 	<ol style="list-style-type: none"> 1. Perform the SCR Bridge Test. 2. Perform the T1 Transformer Test. 3. Check the current control for proper operation. Normal resistance is 10k ohms. See wiring diagram. 4. The control board may be faulty.

 **CAUTION**

If for any reason you do not understand the test procedures or are unable to perform the test/repairs safely, contact the Lincoln Electric Service Department for electrical troubleshooting assistance before you proceed. Call 1-888-935-3877.

PRECISION TIG 185



Return to Section TOC

Return to Section TOC

Return to Section TOC

Return to Section TOC

Return to Master TOC

Return to Master TOC

Return to Master TOC

Return to Master TOC

TROUBLESHOOTING GUIDE

Observe Safety Guidelines detailed in the beginning of this manual.

PROBLEMS (SYMPTOMS)	POSSIBLE AREAS OF MISADJUSTMENT(S)	RECOMMENDED COURSE OF ACTION
TIG MODE PROBLEMS		
<p>Machine output is intermittently lost. Gas flow and high frequency are also interrupted.</p>	<ol style="list-style-type: none"> 1. The problem may be caused by high frequency interference. Make sure that the machine is grounded properly according to the installation instructions. If there are other high frequency sources in the area, make certain that they are grounded properly. 2. Make sure the Amptrol is operating properly. 3. Check to make sure that the input voltage is correct for the machine reconnect configuration. Refer to Reconnect Procedure in the Installation section of this manual. 	<ol style="list-style-type: none"> 1. Check for loose or faulty connection on the leads between the remote receptacle and plug J5 on the control board. See wiring diagram. 2. Check the plugs on the control board for loose connections. 3. The control board may be faulty.

 **CAUTION**

If for any reason you do not understand the test procedures or are unable to perform the test/repairs safely, contact the Lincoln Electric Service Department for electrical troubleshooting assistance before you proceed. Call 1-888-935-3877.

PRECISION TIG 185



Return to Section TOC

Return to Section TOC

Return to Section TOC

Return to Section TOC

Return to Master TOC

Return to Master TOC

Return to Master TOC

Return to Master TOC

TROUBLESHOOTING GUIDE

Observe Safety Guidelines detailed in the beginning of this manual.

PROBLEMS (SYMPTOMS)	POSSIBLE AREAS OF MISADJUSTMENT(S)	RECOMMENDED COURSE OF ACTION
TIG MODE PROBLEMS		
The arc "flutters" when TIG welding.	<ol style="list-style-type: none"> 1. The tungsten electrode may be too large in diameter for the current setting. 2. The tungsten tip may not be "sharp" enough. 3. The gas shielding may be insufficient. Increase the gas flow and or reduce the tungsten stickout beyond the gas cup. 4. Check for contaminated gas or leaks in the gas line, torch, or connections. 5. If a helium blend is used as a shielding gas then reduce the percentage of helium. 	<ol style="list-style-type: none"> 1. Check the polarity switch for proper operation and loose or faulty lead connections. See wiring diagram. 2. Perform the SCR Bridge Test. 3. Check for loose or faulty connections at the shunt. (leads #221 and #222). 4. Check components R3 and C4 in the high voltage transformer primary circuit. Replace if necessary. See wiring diagram. 5. The control board may be faulty. Replace.
The arc "pulsates" when AC TIG welding.	<ol style="list-style-type: none"> 1. Make sure the gas and procedure are correct for the process being used. 	<ol style="list-style-type: none"> 1. Check the micro switch S2A on the polarity switch. It may be stuck closed. See wiring diagram.

 **CAUTION**

If for any reason you do not understand the test procedures or are unable to perform the test/repairs safely, contact the Lincoln Electric Service Department for electrical troubleshooting assistance before you proceed. Call 1-888-935-3877.

PRECISION TIG 185



Return to Section TOC

Return to Section TOC

Return to Section TOC

Return to Section TOC

Return to Master TOC

Return to Master TOC

Return to Master TOC

Return to Master TOC

TROUBLESHOOTING GUIDE

Observe Safety Guidelines detailed in the beginning of this manual.

PROBLEMS (SYMPTOMS)	POSSIBLE AREAS OF MISADJUSTMENT(S)	RECOMMENDED COURSE OF ACTION
TIG WELDING PROBLEMS		
Black areas along weld bead.	<ol style="list-style-type: none"> 1. Clean any oily or organic contamination from the work piece. 2. Tungsten electrode may be contaminated. Replace or sharpen. 3. Check for contaminated gas or leaks in the gas line, torch, or associated connections. 4. The gas shielding may be insufficient. Increase gas flow: reduce tungsten stickout beyond the gas cup. 	<ol style="list-style-type: none"> 1. This may be a welding procedure problem. Contact The Lincoln Electric Service Department, 1-888-935-3877.
Weak high frequency - machine has normal welding.	<ol style="list-style-type: none"> 1. Check for loose or faulty connections at the torch and/or welding cables. 2. The gas shielding may be insufficient. Increase gas flow: reduce tungsten stickout beyond the gas cup. 3. Check spark gap operation and setting. Normal is (0.015"). Refer to Maintenance section of this manual. 4. The work and electrode cables may be in poor condition allowing the high frequency to "leak off". Use good quality cables with a high natural rubber content, such as Lincoln Stable Arc Cable. Cables should be as short as possible. 	<ol style="list-style-type: none"> 1. Make sure that 115VAC is being applied to the primary of the high voltage transformer (T3). See wiring diagram. 2. Check for any open or arcing high frequency component. Replace as required. (Examples: C3, R3, C4) 3. If spark is weak at the spark gap, check or replace the high frequency circuit. (Examples: T3, L3, L4).

 **CAUTION**

If for any reason you do not understand the test procedures or are unable to perform the test/repairs safely, contact the Lincoln Electric Service Department for electrical troubleshooting assistance before you proceed. Call 1-888-935-3877.

PRECISION TIG 185



Return to Section TOC

Return to Section TOC

Return to Section TOC

Return to Section TOC

Return to Master TOC

Return to Master TOC

Return to Master TOC

Return to Master TOC

TROUBLESHOOTING GUIDE

Observe Safety Guidelines detailed in the beginning of this manual.

PROBLEMS (SYMPTOMS)	POSSIBLE AREAS OF MISADJUSTMENT(S)	RECOMMENDED COURSE OF ACTION
TIG WELDING PROBLEMS		
<p>High frequency "spark" is present at tungsten electrode, but operator is unable to establish a welding arc. Machine has normal open circuit voltage. Refer to Technical Specifications in the Installation Chapter.</p>	<ol style="list-style-type: none"> 1. The torch may be faulty. Check or replace. 2. The current control may be set too low. 3. The tungsten electrode may be contaminated. Replace or sharpen. 4. The electrode may be too large for the process. 5. If a helium blend is being used as a shielding gas, then reduce the percentage of helium. 6. Check the welding cables for loose or faulty connections. 	<ol style="list-style-type: none"> 1. This may be a welding procedure problem. <p>Contact The Lincoln Electric Service Department 1-888-935-3877.</p>

CAUTION

If for any reason you do not understand the test procedures or are unable to perform the test/repairs safely, contact the Lincoln Electric Service Department for electrical troubleshooting assistance before you proceed. Call 1-888-935-3877.

PRECISION TIG 185



Return to Section TOC

Return to Section TOC

Return to Section TOC

Return to Section TOC

Return to Master TOC

Return to Master TOC

Return to Master TOC

Return to Master TOC

TROUBLESHOOTING GUIDE

Observe Safety Guidelines detailed in the beginning of this manual.

PROBLEMS (SYMPTOMS)	POSSIBLE AREAS OF MISADJUSTMENT(S)	RECOMMENDED COURSE OF ACTION
TIG WELDING PROBLEMS		
<p>No high frequency. Machine is in the TIG mode and has normal output.</p>	<ol style="list-style-type: none"> 1. If the machine location is in a highly dirty environment with conductive contaminants, check and clean the spark gap with a low pressure air stream per the maintenance instructions. 2. Check spark gap operation and setting. Normal is (0.020"). Refer to <i>Maintenance</i> section of this manual. 	<ol style="list-style-type: none"> 1. Check the high voltage transformer (T3). The normal resistance of the secondary winding of the high voltage transformer is 12.5k ohms. <div style="background-color: black; color: white; padding: 5px; text-align: center;">⚠ WARNING</div> <p>ELECTRIC SHOCK CAN KILL. When 115VAC is applied to the primary of T3. A very high voltage is developed on the secondary winding. For assistance call the Lincoln Electric Service Department 1-888-935-3877.</p> <hr style="border-top: 1px dashed black;"/> <ol style="list-style-type: none"> 2. Check the values of R3, and C4. 3. Perform the T1 Transformer Test. 4. The control board may be faulty. Replace.
<p>No gas flow when Amptrol is activated in the TIG mode. Machine has normal output - fan runs. A "click" can be heard indicating that the gas solenoid valve is operating.</p>	<ol style="list-style-type: none"> 1. The gas supply is either empty or not turned on. 2. The flow regulator may be set too low. 3. Check the gas hose for kinks or blockages. 4. Check the filter screen inside gas inlet fitting to solenoid valve. 	<ol style="list-style-type: none"> 1. Possible gas supply problems. Consult your local welder/gas distributor.

CAUTION

If for any reason you do not understand the test procedures or are unable to perform the test/repairs safely, contact the Lincoln Electric Service Department for electrical troubleshooting assistance before you proceed. Call 1-888-935-3877.

PRECISION TIG 185



Return to Section TOC

Return to Master TOC

TROUBLESHOOTING GUIDE

Observe Safety Guidelines detailed in the beginning of this manual.

PROBLEMS (SYMPTOMS)	POSSIBLE AREAS OF MISADJUSTMENT(S)	RECOMMENDED COURSE OF ACTION
TIG WELDING PROBLEMS		
When AC TIG welding, the arc is erratic and there is a loss of "cleaning" of the work piece.	<ol style="list-style-type: none"> 1. The tungsten electrode may be too small for the process. Use a larger diameter tungsten or a pure tungsten. 2. If a helium blend is used as a shielding gas, then reduce the percentage of helium. 	<ol style="list-style-type: none"> 1. Check components R3 and C4 in the high voltage transformer primary circuit. 2. Perform the SCR Bridge Test.
The end of the tungsten electrode melts away.	<ol style="list-style-type: none"> 1. The welding current is too high for the electrode type and or size. See Table B.1 in the Operation Section. 	<ol style="list-style-type: none"> 1. This may be a welding procedure problem. Contact The Lincoln Electric Service Department 1-888-935-3877.



CAUTION

If for any reason you do not understand the test procedures or are unable to perform the test/repairs safely, contact the Lincoln Electric Service Department for electrical troubleshooting assistance before you proceed. Call 1-888-935-3877.

PRECISION TIG 185



Return to Section TOC

Return to Section TOC

Return to Section TOC

Return to Section TOC

Return to Master TOC

Return to Master TOC

Return to Master TOC

Return to Master TOC

TROUBLESHOOTING GUIDE

Observe Safety Guidelines detailed in the beginning of this manual.

PROBLEMS (SYMPTOMS)	POSSIBLE AREAS OF MISADJUSTMENT(S)	RECOMMENDED COURSE OF ACTION
STICK WELDING PROBLEMS		
Stick electrode "Blasts Off" when arc is struck.	<ol style="list-style-type: none"> 1. Weld current may be set too high for electrode size. Reduce current control setting, or use a larger diameter electrode. 	<ol style="list-style-type: none"> 1. Perform the SCR Bridge Test. 2. The control board may be faulty. Replace.
The stick electrode "sticks" in the puddle.	<ol style="list-style-type: none"> 1. The weld current may be set too low. Increase the current control setting or use a smaller diameter electrode. 	
Variable or sluggish welding arc when welding in the Stick mode.	<ol style="list-style-type: none"> 1. Check work and electrode cables for loose or poor connections. 2. The weld cables may be too small or too long to permit the desired current to flow. 3. The weld current may be set too low. 	<ol style="list-style-type: none"> 1. Check the polarity switch for excessive wear or faulty connections. 2. Check interior connection of the heavy current carrying leads.

CAUTION

If for any reason you do not understand the test procedures or are unable to perform the test/repairs safely, contact the Lincoln Electric Service Department for electrical troubleshooting assistance before you proceed. Call 1-888-935-3877.

PRECISION TIG 185



Return to Section TOC

Return to Section TOC

Return to Section TOC

Return to Section TOC

Return to Master TOC

Return to Master TOC

Return to Master TOC

Return to Master TOC

HIGH FREQUENCY CIRCUIT DISABLE PROCEDURE



WARNING

Service and repair should be performed by only Lincoln Electric factory trained personnel. Unauthorized repairs performed on this equipment may result in danger to the technician or machine operator and will invalidate your factory warranty. For your safety and to avoid electrical shock, please observe all safety notes and precautions detailed throughout this manual.

If for any reason you do not understand the test procedures or are unable to perform the test / repairs safely, contact the Lincoln Electric Service Department for electrical troubleshooting assistance before you proceed. Call 1-888-935-3877.

TEST DESCRIPTION

This procedure will disable the high frequency circuit. The technician will then be able to take voltage measurements without the possibility of high frequency damage to his test equipment.

MATERIALS NEEDED

- 3/8" Nutdriver
- 5/64" Allen type wrench
- .020" feeler gauge



WARNING

HIGH VOLTAGE IS STILL PRESENT IN THE HIGH FREQUENCY CIRCUIT.

HIGH FREQUENCY CIRCUIT DISABLE PROCEDURE

PROCEDURE

1. Remove input power to the TIG185 machine.
2. Using the 3/8" nutdriver remove the right side panel.
3. Locate the Spark Gap Assembly at the right side of the machine. See Figure F.1.
4. With the 5/64" Allen type wrench loosen the set screw holding the upper electrode in place.
5. Increase the distance between the electrodes to at least 3/8" by sliding one electrode away from the other electrode. Secure the one electrode in this position.
6. This should disable the high frequency circuit. **Visually check to make sure high frequency sparking is NOT present before connecting any test equipment to the TIG 185 machine.**
7. When voltage testing and scope measurements are complete reset the spark gap electrodes to .020" air gap. Tighten the set screw using the 5/64" Allen wrench.

FIGURE F.1 SPARK GAP ASSEMBLY

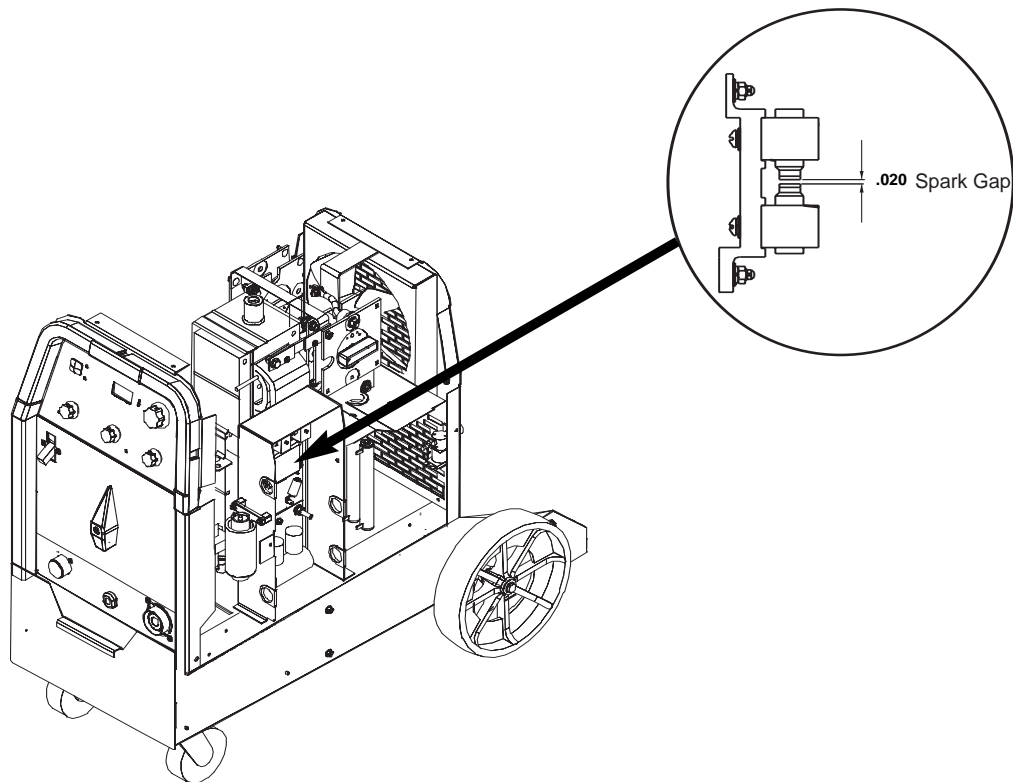

LEFT SIDE OF MACHINE

PRECISION TIG 185



T1 TRANSFORMER TEST



WARNING

Service and repair should be performed by only Lincoln Electric factory trained personnel. Unauthorized repairs performed on this equipment may result in danger to the technician or machine operator and will invalidate your factory warranty. For your safety and to avoid electrical shock, please observe all safety notes and precautions detailed throughout this manual.

If for any reason you do not understand the test procedures or are unable to perform the test / repairs safely, contact the Lincoln Electric Service Department for electrical troubleshooting assistance before you proceed. Call 1-888-935-3877.

TEST DESCRIPTION

This procedure will determine if the correct voltage is being applied to the primary of the T1 transformer and also if the correct voltages are being induced on the secondary windings of the transformer.

MATERIALS NEEDED

Volt/Ohm Meter
Precision TIG 185 Wiring Diagrams
3/8" nutdriver

PRECISION TIG 185



Return to Section TOC
Return to Master TOC
Return to Section TOC
Return to Master TOC
Return to Section TOC
Return to Master TOC
Return to Section TOC
Return to Master TOC

T1 TRANSFORMER TEST *(continued)*

TEST PROCEDURE

1. Remove main supply power to the machine.
2. Using the 3/8" nutdriver remove the case wrap-around cover.
3. Locate plugs J3 and J4 on the control board. See Figure F.2.
4. Carefully apply the correct input power making certain the reconnect configuration at the input switch is correct for the input voltage applied. Turn the TIG 185 ON.
5. Using the voltmeter carefully test for the correct transformer secondary voltages per Table F.1.

FIGURE F.2 - Plugs J3 & J4 on Control Board

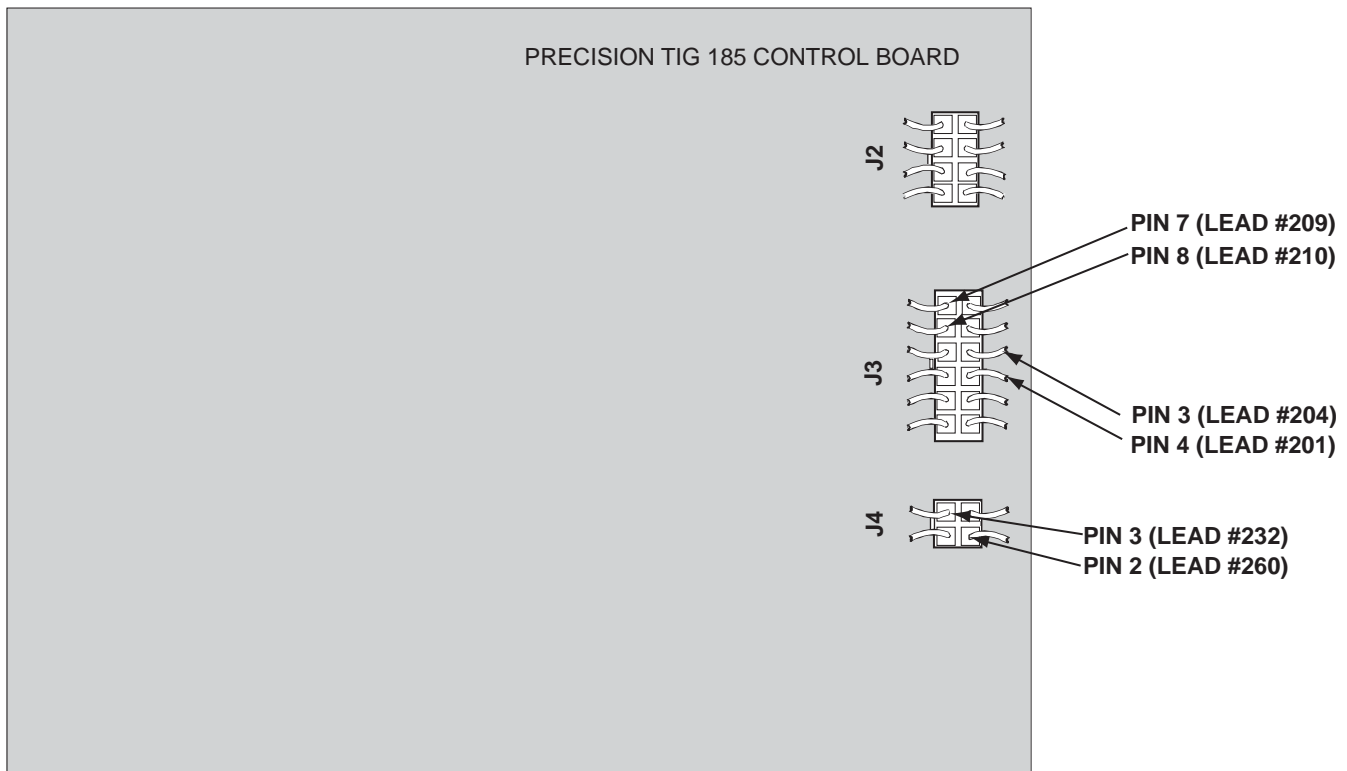

PRECISION TIG 185



T1 TRANSFORMER TEST *(continued)*

6. If all of the secondary voltages are correct the T1 transformer is functioning properly.
- A. If all of the secondary voltages are missing or incorrect make certain that the correct input voltage is being applied to the correct primary leads. See Table F.1.
- B. If the correct input voltage is being applied to the primary leads and any or all of the secondary voltages are incorrect the T1 transformer may faulty. See **Main Transformer and Output**
- Choke Removal and Replacement.** Also check the leads for broken or loose connections between plugs J3, J4 and the T1 transformer.
7. Replace case wrap-around cover.

TABLE F.1 T1 TRANSFORMER VOLTAGE

TEST POINTS	ACCEPTABLE VOLTAGES
SECONDARY WINDINGS	SECONDARY VOLTAGES
PLUG J3 PIN 8 (LEAD #210) TO PLUG J3 PIN 7 (LEAD #209)	18VAC
PLUG J3 PIN 4 (LEAD #201) TO PLUG J3 PIN 3 (LEAD #204)	18VAC
PLUG J4 PIN 2 (LEAD #260) TO PLUG J4 PIN 3 (LEAD #232)	CHECK DURING FIRST 5 SECONDS OF POWER UP 115VAC
X1 TO X2	80 VAC
PRIMARY WINDINGS	PRIMARY VOLTAGES
H1 TO H2	208VAC
H1 TO H3	230VAC

NOTE: If the input voltages vary the secondary voltages will vary accordingly.

Return to Section TOC
Return to Master TOC

Return to Section TOC
Return to Master TOC

Return to Section TOC
Return to Master TOC

Return to Section TOC
Return to Master TOC

PRECISION TIG 185



STATIC SCR TEST



WARNING

Service and repair should be performed by only Lincoln Electric factory trained personnel. Unauthorized repairs performed on this equipment may result in danger to the technician or machine operator and will invalidate your factory warranty. For your safety and to avoid electrical shock, please observe all safety notes and precautions detailed throughout this manual.

If for any reason you do not understand the test procedures or are unable to perform the test / repairs safely, contact the Lincoln Electric Service Department for electrical troubleshooting assistance before you proceed. Call 1-888-935-3877.

TEST DESCRIPTION

This procedure is a quick check to determine if an SCR is shorted or "leaky". See machine waveform section for normal and abnormal SCR waveforms.

MATERIALS NEEDED

- Volt/Ohm Meter (Analog)
- Precision TIG 185 Wiring Diagrams
- 3/8" nutdriver
- SCR Heat Sink Assembly Drawing

STATIC SCR TEST (continued)

TEST PROCEDURE

1. Remove main supply power to the TIG 185 and remove the case wrap-around cover.
2. Locate and remove plug J2 from the control board. See Figure F.3.

Figure F.3 - Plug J2 Location on Control Board

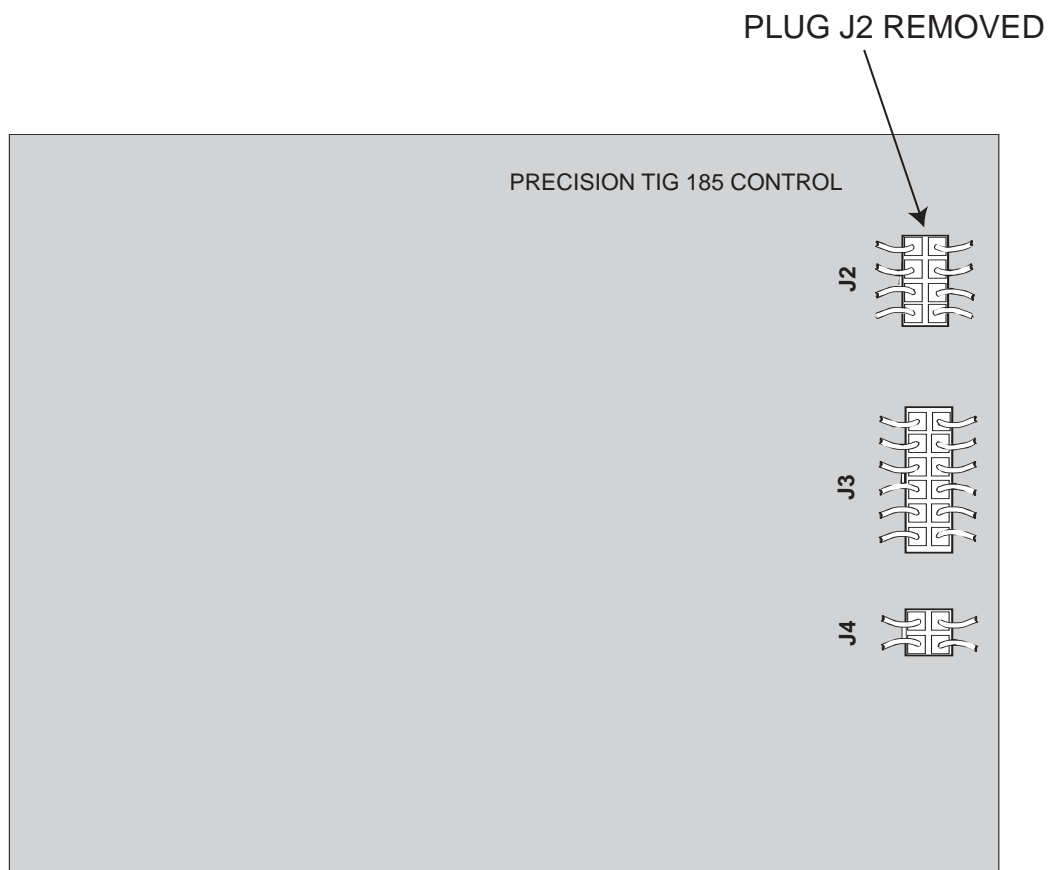

PRECISION TIG 185



STATIC SCR TEST (continued)

3. Using an analog ohmmeter test the resistance from anode to cathode of SCR1. Reverse the meter leads and check from cathode to anode of SCR1. See Figure F.4. If a low resistance is indicated in either direction SCR1 is faulty. Replace SCR Bridge Assembly. See **SCR Bridge Assembly Removal and Replacement**.
4. Repeat Step #3 testing SCR2, SCR3 and SCR4.
5. The further check the SCR's functions use an SCR tester and proceed to the **Active SCR Test**.

FIGURE F.4 SCR TEST POINTS

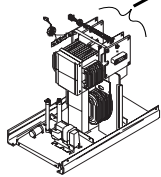
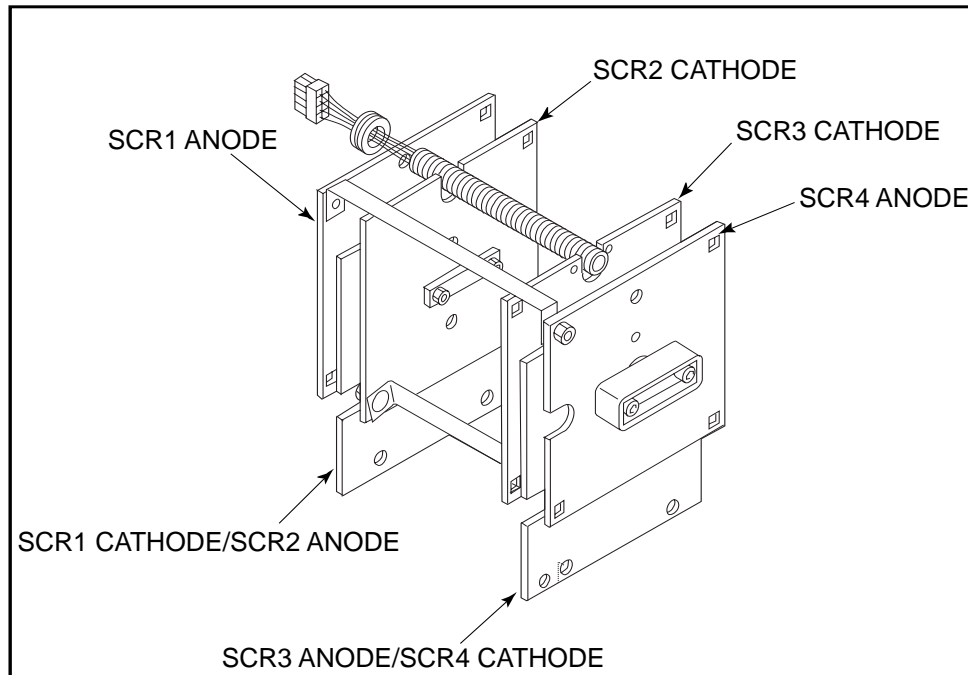

Return to Section TOC
Return to Master TOC

Return to Section TOC
Return to Master TOC

Return to Section TOC
Return to Master TOC

Return to Section TOC
Return to Master TOC

PRECISION TIG 185



ACTIVE SCR TEST



WARNING

Service and repair should be performed by only Lincoln Electric factory trained personnel. Unauthorized repairs performed on this equipment may result in danger to the technician or machine operator and will invalidate your factory warranty. For your safety and to avoid electrical shock, please observe all safety notes and precautions detailed throughout this manual.

If for any reason you do not understand the test procedures or are unable to perform the test / repairs safely, contact the Lincoln Electric Service Department for electrical troubleshooting assistance before you proceed. Call 1-888-935-3877.

TEST DESCRIPTION

This procedure will determine if the device is able to be gated "ON" and conduct current from anode to cathode.

MATERIALS NEEDED

An SCR tester as outlined in this procedure.

Precision TIG 185 Wiring Diagrams

3/8" nutdriver

PRECISION TIG 185



ACTIVE SCR TEST (continued)

TEST PROCEDURE

1. Remove main supply power to the TIG 185 machine.
2. Locate and remove plug J2 from the control board. See **Figure F.3**.
3. Perform test procedure as outlined in Figure F.5. Repeat test for all four SCRs. See **Figure F.6**.
4. Construct the circuit outlined in Figure F.5. One 6V lantern battery can be used. Resistor values are $\pm 10\%$. The voltmeter scale should be low, approximately 0-5 or 0-10 volts.
5. Battery Test - Check the battery by shorting leads (A) and (C) and then close switch SW-1. Re-place battery if voltage is less than 4.5 volts.

FIGURE F.5 ACTIVE SCR TEST SETUP

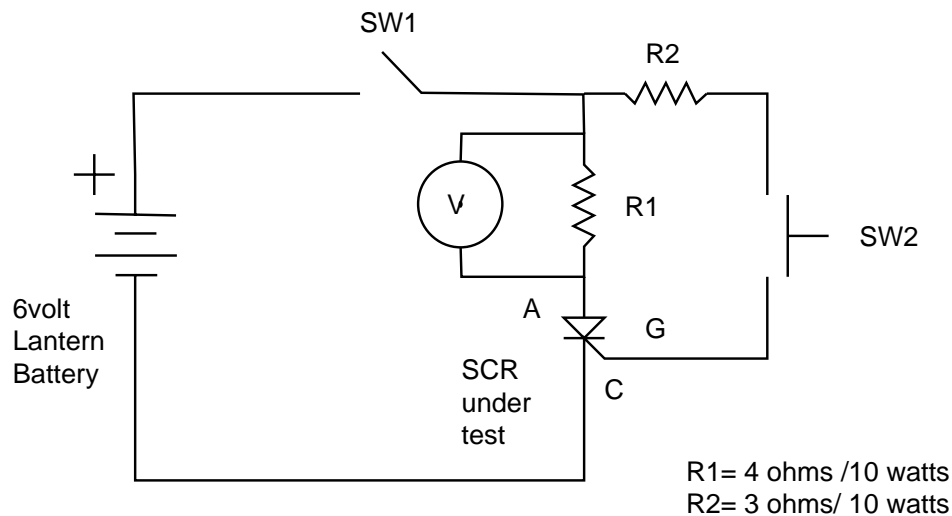

To test SCRs construct the circuit outlined above. Resistor values are plus or minus ten percent. The voltmeter scale should be low, approximately 0-5 or 0-10 volts DC.

ACTIVE SCR TEST (continued)

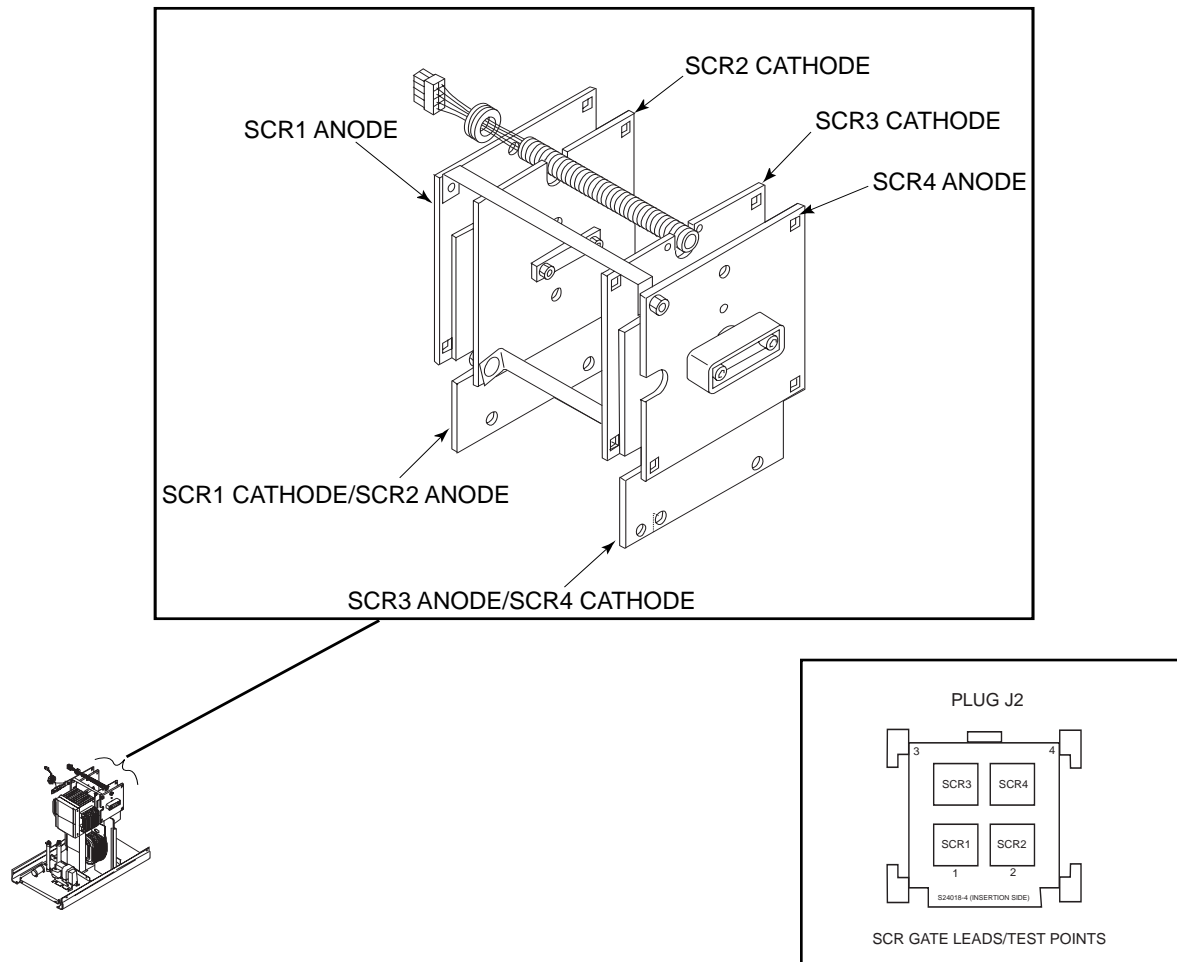

FIGURE F.6 SCR GATE LOCATIONS

6. Connect SCR into the test circuit as shown (A) lead to anode (C) lead to cathode and (G) lead to the gate.
7. Close switch SW-1 (switch SW-2 should open), voltmeter should read zero. If the voltmeter reads higher than zero the SCR is shorted.
8. With switch SW-1 closed, close switch SW-2 for two seconds and release. The voltmeter should read 3 to 6 volts before and after switch SW-2 is released. If the voltmeter does not read, or reads only while SW-2 is depressed, the SCR or battery is defective (repeat Battery Test Procedure above).
9. Open switch SW-1, disconnect the gate lead (G) and reverse the (A) and (C) leads on the SCR. Close switch SW-1. The voltmeter should read zero. If the voltage is higher than zero, the SCR is shorted.
10. Replace SCR Bridge Assembly if any SCRs do not pass the test in Step #3. See **SCR Bridge Assembly Removal and Replacement**.
11. Replace plug J2 into the control board.
12. Replace the case wrap-around cover.

PRECISION TIG 185



Return to Section TOC
Return to Master TOC

Return to Section TOC
Return to Master TOC

Return to Section TOC
Return to Master TOC

Return to Section TOC
Return to Master TOC

PRECISION TIG 185



NORMAL OPEN CIRCUIT VOLTAGE WAVEFORM
AC TIG MODE

⚠ CAUTION

HIGH VOLTAGE / HIGH FREQUENCY can damage test equipment.

- Perform all voltage and waveform checks with high frequency circuit OFF.
- Perform High Frequency Disable Procedure.

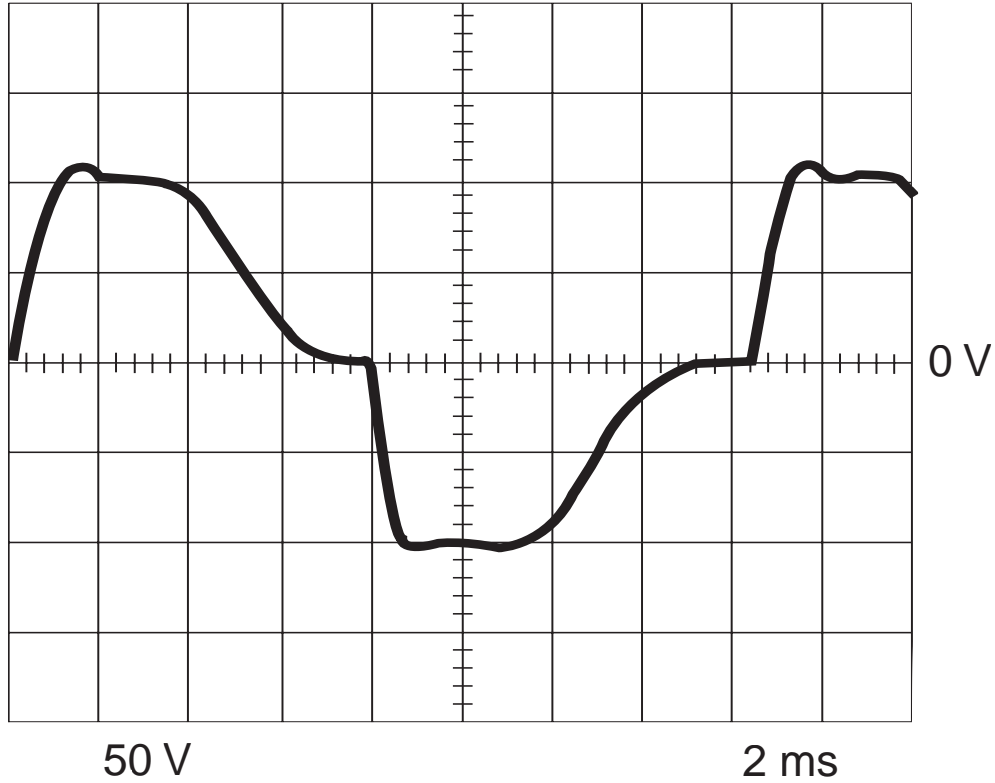

This is the typical AC output voltage waveform generated from a properly operating machine. Note that each vertical division represents 50 volts and that each horizontal division represents 2 milliseconds in time.

Note: Scope probes connected at machine output terminals: (+) probe to electrode, (-) probe to work.

SCOPE SETTINGS

Volts/Div.	50 V/Div.
Horizontal Sweep	2 ms/Div.
Coupling	DC
Trigger	Internal

Return to Section TOC

Return to Section TOC

Return to Section TOC

Return to Section TOC

Return to Section TOC

Return to Section TOC

Return to Master TOC

Return to Master TOC

Return to Master TOC

Return to Master TOC

Return to Master TOC

Return to Master TOC

NORMAL OPEN CIRCUIT VOLTAGE WAVEFORM
DC TIG MODE

⚠ CAUTION

HIGH VOLTAGE / HIGH FREQUENCY can damage test equipment.

- Perform all voltage and waveform checks with high frequency circuit OFF.
- Perform High Frequency Disable Procedure.

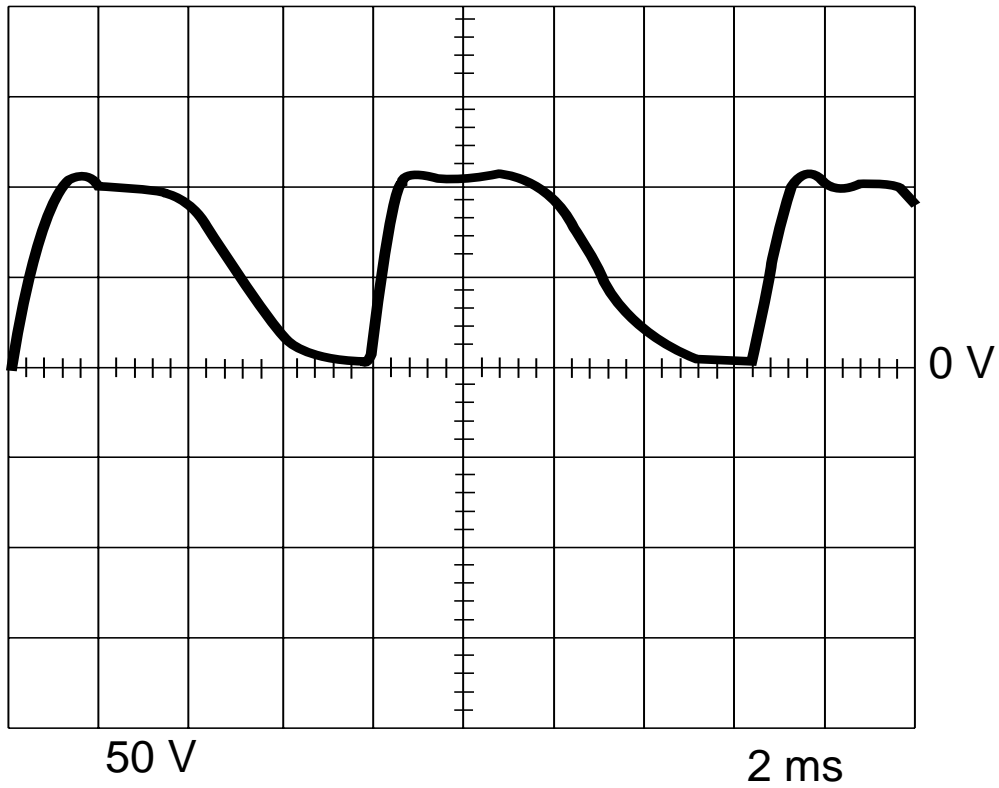

This is the typical DC (+) output voltage waveform generated from a properly operating machine. Note that each vertical division represents 50 volts and that each horizontal division represents 2 milliseconds in time.

Note: Scope probes connected at machine output terminals: (+) probe to electrode, (-) probe to work.

SCOPE SETTINGS

Volts/Div.	50 V/Div.
Horizontal Sweep	2 ms/Div.
Coupling	DC
Trigger	Internal



Return to Section TOC
Return to Section TOC
Return to Section TOC
Return to Section TOC
Return to Section TOC
Return to Section TOC

NORMAL OPEN CIRCUIT VOLTAGE WAVEFORM
AC STICK MODE

⚠ CAUTION

HIGH VOLTAGE / HIGH FREQUENCY can damage test equipment.

- Perform all voltage and waveform checks with high frequency circuit OFF.
- Perform High Frequency Disable Procedure.

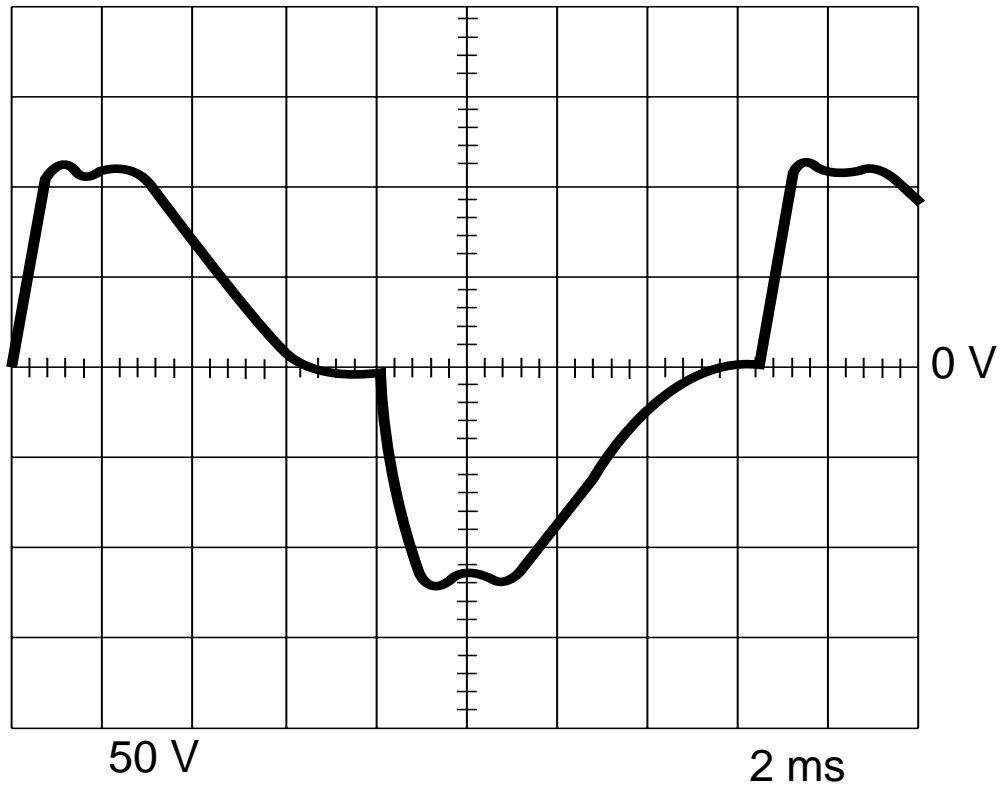

This is the typical AC output voltage waveform generated from a properly operating machine. Note that each vertical division represents 50 volts and that each horizontal division represents 2 milliseconds in time.

Note: Scope probes connected at machine output terminals: (+) probe to electrode, (-) probe to work.

SCOPE SETTINGS

Volts/Div.	50 V/Div.
Horizontal Sweep	2 ms/Div.
Coupling	DC
Trigger	Internal

Return to Section TOC
Return to Master TOC

Return to Section TOC
Return to Master TOC

Return to Section TOC
Return to Master TOC

Return to Section TOC
Return to Master TOC

NORMAL OPEN CIRCUIT VOLTAGE WAVEFORM DC STICK MODE

⚠ CAUTION

HIGH VOLTAGE / HIGH FREQUENCY can damage test equipment.

- Perform all voltage and waveform checks with high frequency circuit OFF.
- Perform High Frequency Disable Procedure.

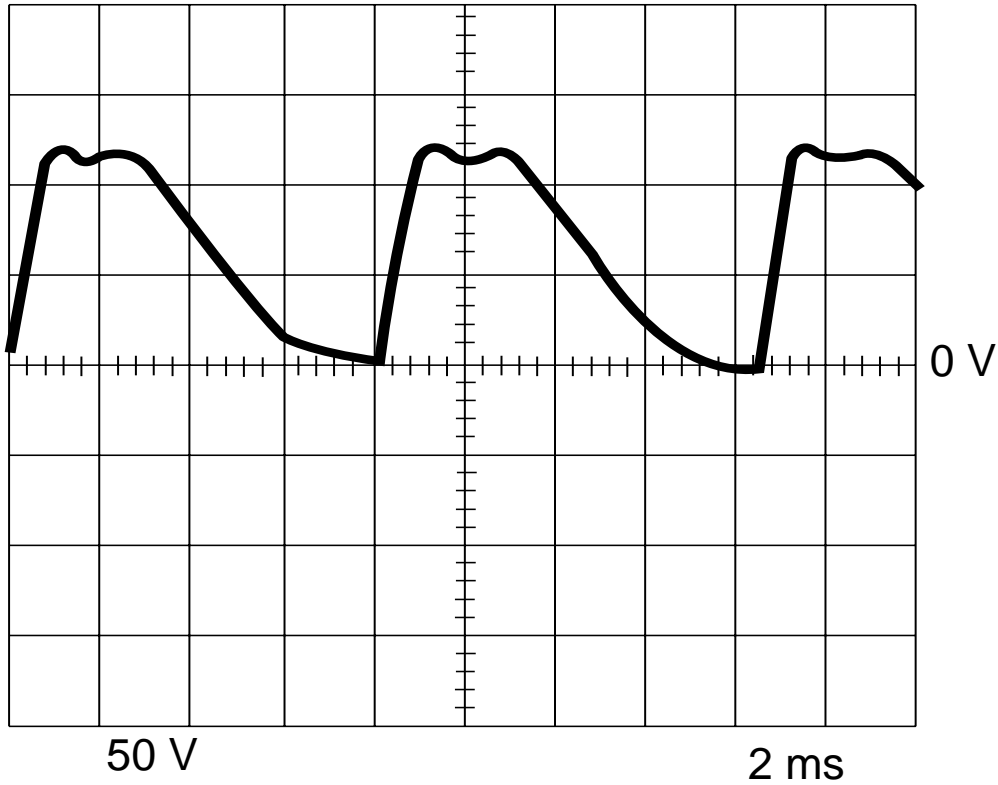

This is the typical DC (+) output voltage waveform generated from a properly operating machine. Note that each vertical division represents 50 volts and that each horizontal division represents 2 milliseconds in time.

Note: Scope probes connected at machine output studs: (+) probe to electrode, (-) probe to work.

SCOPE SETTINGS

Volts/Div.	50 V/Div.
Horizontal Sweep	2 ms/Div.
Coupling	DC
Trigger	Internal

Return to Section TOC
Return to Master TOC

Return to Section TOC
Return to Master TOC

Return to Section TOC
Return to Master TOC

Return to Section TOC
Return to Master TOC

TYPICAL OUTPUT VOLTAGE WAVEFORM - MACHINE LOADED AC TIG MODE

⚠ CAUTION

HIGH VOLTAGE / HIGH FREQUENCY can damage test equipment.

- Perform all voltage and waveform checks with high frequency circuit OFF.
- Perform High Frequency Disable Procedure.

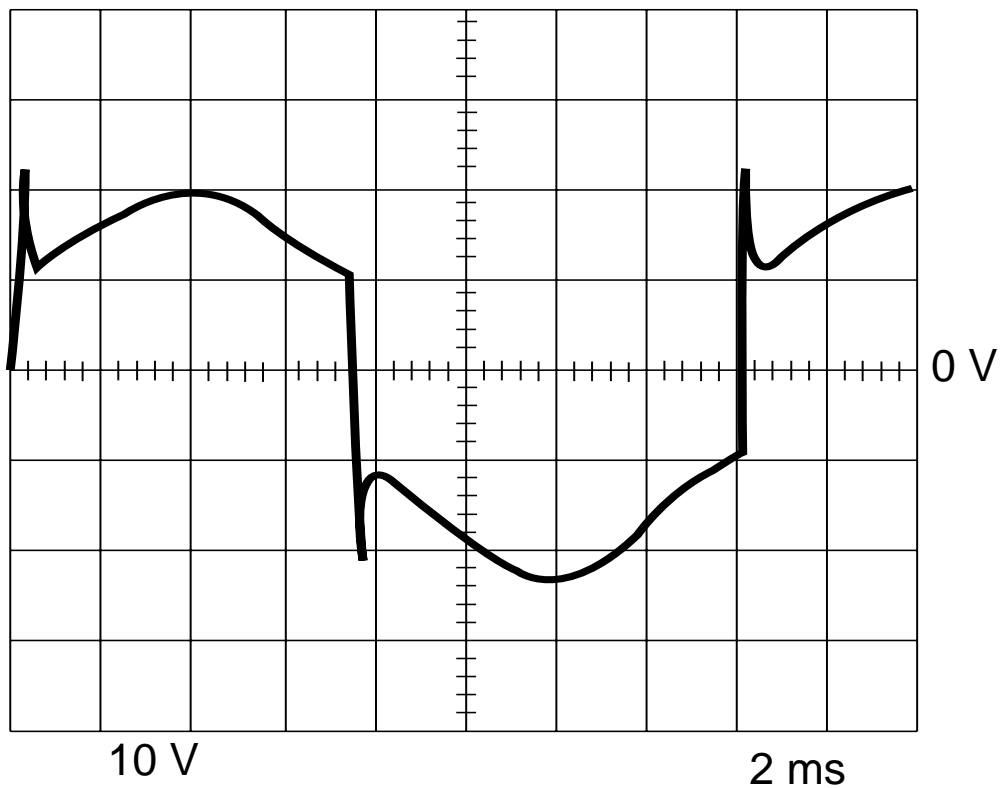

MACHINE LOADED TO 180 AMPS AT 16VDC.

This is the typical AC output voltage waveform generated from a properly operating machine. Note that each vertical division represents 10 volts and that each horizontal division represents 2 milliseconds in time. The machine was loaded with a resistance grid bank. The grid load meters read 180 amps and 16VDC

SCOPE SETTINGS

Volts/Div.	10 V/Div.
Horizontal Sweep	2 ms/Div.
Coupling	DC
Trigger	Internal

Note: Scope probes connected at machine output terminals: (+) probe to electrode, (-) probe to work.

Return to Section TOC
Return to Master TOC

Return to Section TOC
Return to Master TOC

Return to Section TOC
Return to Master TOC

Return to Section TOC
Return to Master TOC

TYPICAL OUTPUT VOLTAGE WAVEFORM - MACHINE LOADED DC TIG MODE

⚠ CAUTION

HIGH VOLTAGE / HIGH FREQUENCY can damage test equipment.

- Perform all voltage and waveform checks with high frequency circuit OFF.
- Perform High Frequency Disable Procedure.

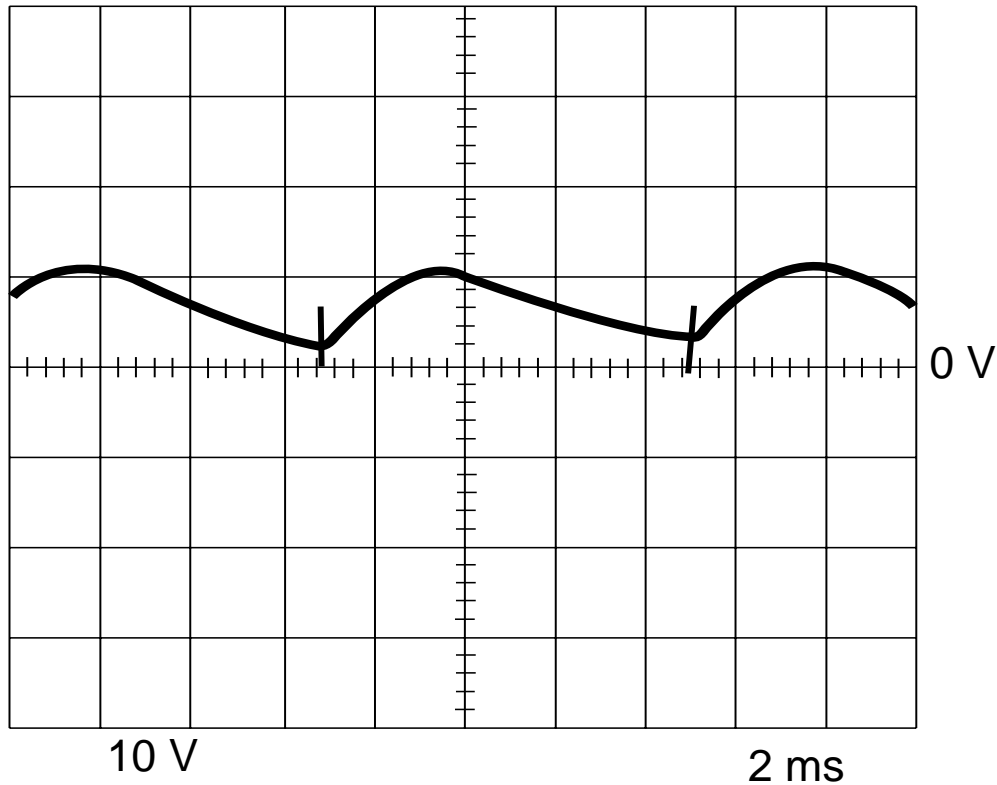

MACHINE LOADED TO 180 AMPS AT 16VDC.

This is the typical DC (+) output voltage waveform generated from a properly operating machine. Note that each vertical division represents 10 volts and that each horizontal division represents 2 milliseconds in time. The machine was loaded with a resistance grid bank. The grid load meters read 180 amps and 16VDC

SCOPE SETTINGS

Volts/Div.	10 V/Div.
Horizontal Sweep	2 ms/Div.
Coupling	DC
Trigger	Internal

Note: Scope probes connected at machine output terminals: (+) probe to electrode, (-) probe to work.

Return to Section TOC
 Return to Section TOC
 Return to Section TOC
 Return to Section TOC
 Return to Master TOC
 Return to Master TOC
 Return to Master TOC
 Return to Master TOC

TYPICAL OUTPUT VOLTAGE WAVEFORM - MACHINE LOADED DC STICK MODE

⚠ CAUTION

HIGH VOLTAGE / HIGH FREQUENCY can damage test equipment.

- Perform all voltage and waveform checks with high frequency circuit OFF.
- Perform High Frequency Disable Procedure.

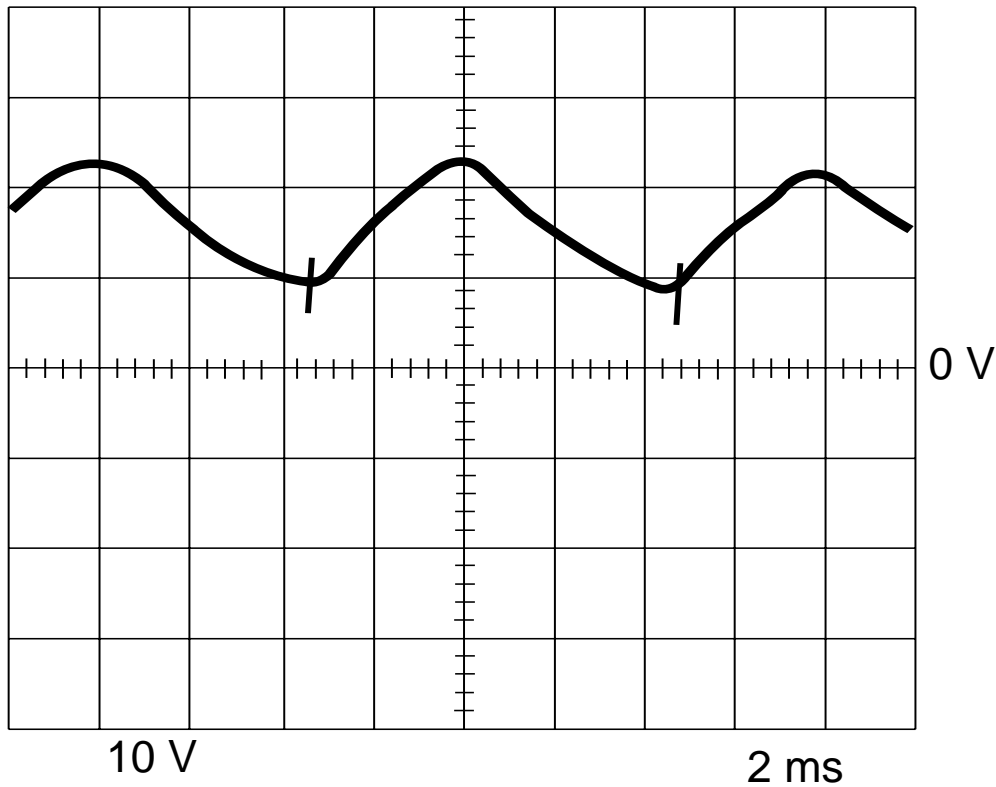

MACHINE LOADED TO 180 AMPS AT 26VDC.

This is the typical AC output voltage waveform generated from a properly operating machine. Note that each vertical division represents 10 volts and that each horizontal division represents 2 milliseconds in time. The machine was loaded with a resistance grid bank. The grid load meters read 180 amps and 26VDC

SCOPE SETTINGS

Volts/Div.	10 V/Div.
Horizontal Sweep	2 ms/Div.
Coupling	DC
Trigger	Internal

Note: Scope probes connected at machine output terminals: (+) probe to electrode, (-) probe to work.

ABNORMAL OPEN CIRCUIT VOLTAGE - DC TIG MODE ONE OUTPUT SCR NOT FUNCTIONING

⚠ CAUTION

HIGH VOLTAGE / HIGH FREQUENCY can damage test equipment.

- Perform all voltage and waveform checks with high frequency circuit OFF.
- Perform High Frequency Disable Procedure.

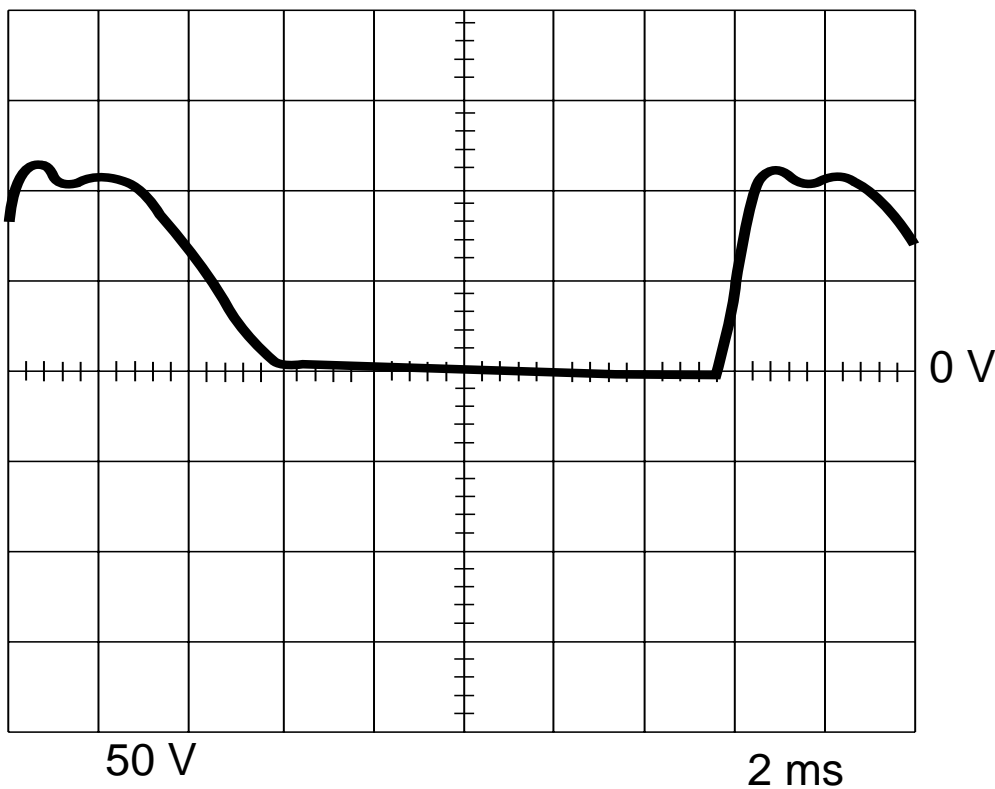

This is NOT the typical DC (+) output voltage waveform. One output SCR is not functioning. Note the “gap” in the waveform. One SCR gate was disconnected to simulate an open or non-functioning output SCR. Note that each vertical division represents 50 volts and that each horizontal division represents 2 milliseconds in time.

SCOPE SETTINGS

Volts/Div.	50 V/Div.
Horizontal Sweep	2 ms/Div.
Coupling	DC
Trigger	Internal

Note: Scope probes connected at machine output terminals: (+) probe to electrode, (-) probe to work.

Return to Section TOC
Return to Section TOC
Return to Section TOC
Return to Section TOC
Return to Section TOC

Return to Master TOC
Return to Master TOC
Return to Master TOC
Return to Master TOC
Return to Master TOC

Return to Section TOC
Return to Master TOC

Return to Section TOC
Return to Master TOC

Return to Section TOC
Return to Master TOC

Return to Section TOC
Return to Master TOC

PRECISION TIG 185



SCR BRIDGE ASSEMBLY REMOVAL AND REPLACEMENT PROCEDURE



WARNING

Service and repair should be performed by only Lincoln Electric factory trained personnel. Unauthorized repairs performed on this equipment may result in danger to the technician or machine operator and will invalidate your factory warranty. For your safety and to avoid electrical shock, please observe all safety notes and precautions detailed throughout this manual.

If for any reason you do not understand the test procedures or are unable to perform the test / repairs safely, contact the Lincoln Electric Service Department for electrical troubleshooting assistance before you proceed. Call 1-888-935-3877.

TEST DESCRIPTION

This procedure will aid the technician in the removal and replacement of the SCR assembly

MATERIALS NEEDED

5/16" nutdriver

3/8" nutdriver

Needle nose pliers

7/16" Wrench

3/8" Wrench

Slot head screwdriver

Dow Corning 340 Heat Sink compound

PRECISION TIG 185



SCR BRIDGE ASSEMBLY REMOVAL AND REPLACEMENT PROCEDURE *(Continued)*

PROCEDURE

1. Remove input power to the TIG 185 machine.
2. Using the 3/8" nutdriver remove the case wrap-around cover.
3. With the slot head screwdriver loosen the input cable strain relief to allow movement of case back.
4. Using the 3/8" nutdriver remove the two lower screws from the case back. See Figure F.7.
5. With the 5/16" nutdriver remove the two screws holding the case back to the internal divider panel. See Figure F.7.
6. Remove the gas hose from the gas solenoid valve.
7. Carefully pull the case back and fan assembly away to allow access to the SCR Bridge Assembly. Support the case back so as not to stress the fan motor leads. It is not necessary to disconnect the fan motor leads.
8. Using the 5/16" nutdriver remove the two screws holding the front panel assembly to the base. See **Figure F.8**.

FIGURE F.7 CASE BACK MOUNTING SCREWS

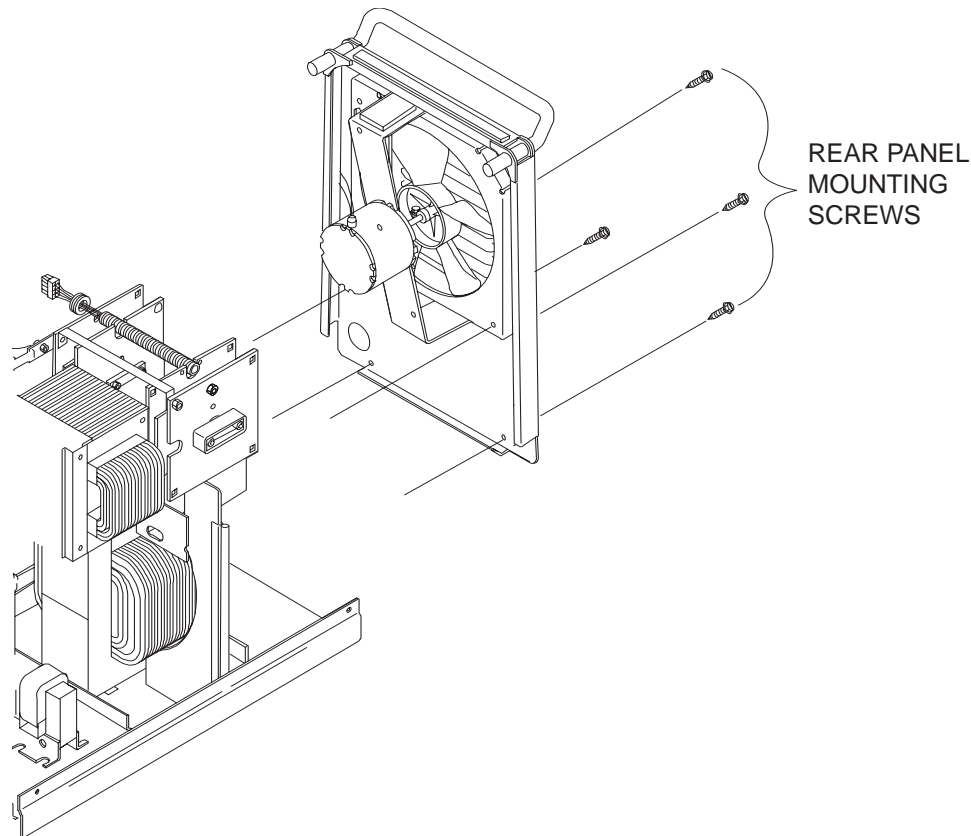

PRECISION TIG 185



SCR BRIDGE ASSEMBLY REMOVAL AND REPLACEMENT PROCEDURE (Continued)

FIGURE F.8 FRONT PANEL MOUNTING SCREWS

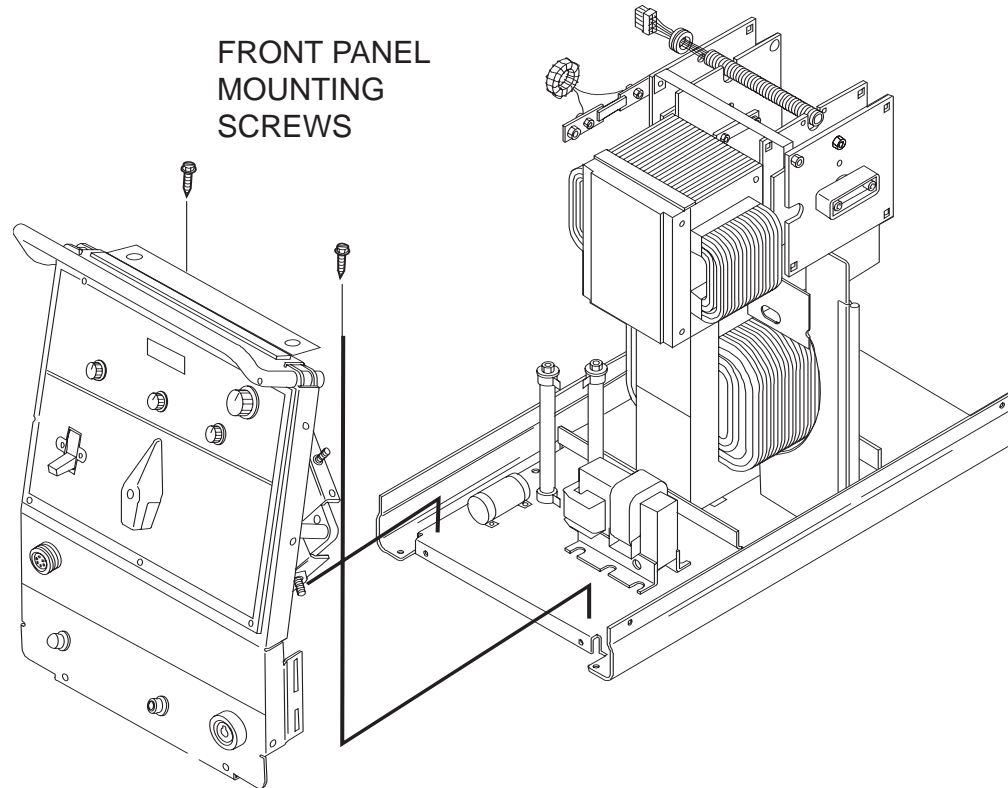

9. Remove plug J2 from the control board. (See **Figure F.9.**) Also remove plug and lead harness from internal divider panel.
10. Carefully slide the internal divider panel away a few inches to allow access to the SCR bridge assembly.
11. Using the 7/16" wrench disconnect the diode pigtail connection from the polarity switch lead. See **Figure F.10.** Cut any necessary cable ties and remove insulating sleeving.
12. Using the 7/16" wrench remove the X2 secondary transformer lead from the left side AC SCR heat sink.
13. With the 7/16" wrench remove the shunt from the SCR bridge left side negative heat sink.
14. Using the 7/16" wrench remove the polarity switch lead from the right side AC SCR heat sink.
15. Using the 7/16" wrench remove the positive lead from the right side positive heat sink.

Note placement of sleeving and cable ties for reassembly.

12. Using the 7/16" wrench remove the

PRECISION TIG 185



SCR BRIDGE ASSEMBLY REMOVAL AND REPLACEMENT PROCEDURE (Continued)

FIGURE F.9 PLUG J2 ON CONTROL BOARD

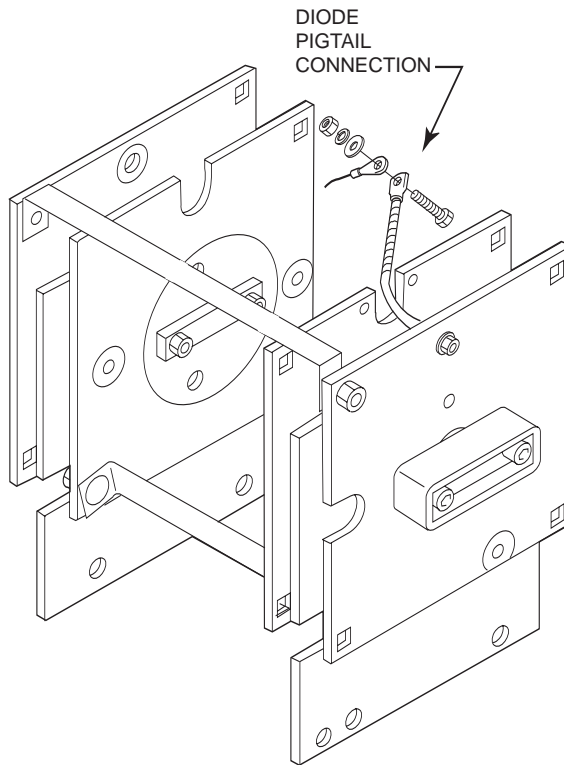
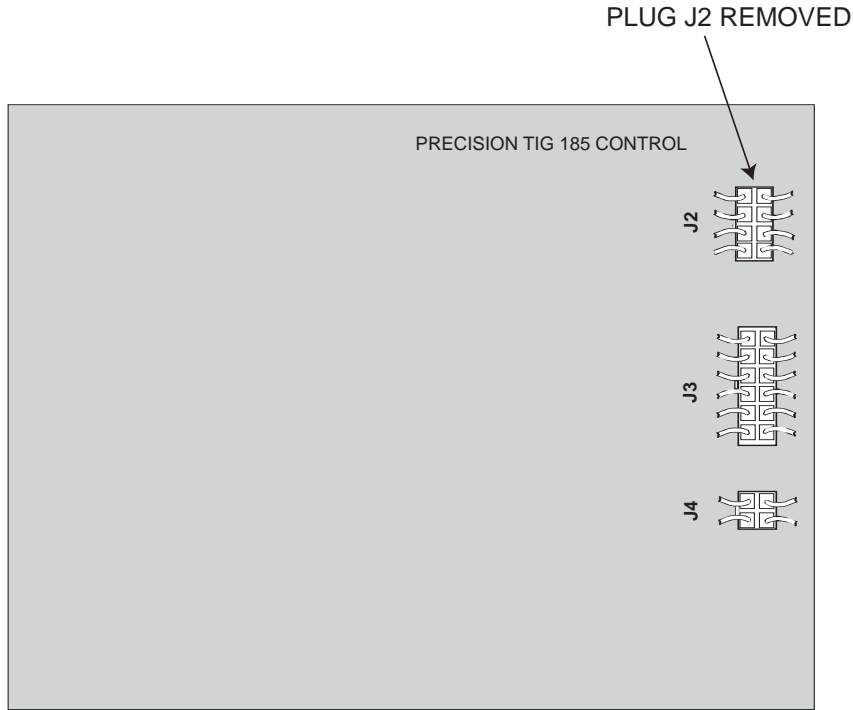

FIGURE F.10 DIODE PIGTAIL CONNECTION TO POLARITY SWITCH LEAD.

PRECISION TIG 185



Return to Section TOC
Return to Section TOC
Return to Section TOC
Return to Section TOC
Return to Master TOC
Return to Master TOC
Return to Master TOC
Return to Master TOC

SCR BRIDGE ASSEMBLY REMOVAL AND REPLACEMENT PROCEDURE *(Continued)*

16. With the 3/8" wrench remove the four mounting screws holding the SCR bridge assembly to the main transformer frame. Note insulator placement.
17. Carefully remove the SCR bridge assembly from the TIG 185 cutting any necessary cable ties.
9. Position the internal divider panel and secure with the screws previously removed.
10. Install the J2 plug into the control board and position the harness in the internal divider panel.
11. Position and install the case back and secure with the screws previously removed.

REPLACEMENT PROCEDURE

1. Carefully place the new SCR bridge assembly in position in the TIG 185.
2. Using the 3/8" wrench install the four mounting screws taking special care that the insulators are in the correct positions.
12. Install the gas hose onto the solenoid valve.
13. Tighten the input cable strain relief.
14. Assemble the case wrap-around cover.

USE DOW CORNING 340 HEAT SINK COMPOUND ON ALL ALUMINUM CONNECTIONS

3. Assemble the positive lead to the right side positive heat sink.
4. Assemble the lead from the polarity switch to the right side AC heat sink. Note: Also connect lead #216
5. Assemble the shunt to the SCR bridge left side negative heat sink.
6. Assemble the X2 secondary transformer lead to the left side AC SCR heat sink. Note: Also connect lead #217
7. Assemble the diode pigtail lead to the polarity switch lead. See **Figure F.10**. Be sure to replace sleeving and secure with cable ties. Position with harness and secure with cable ties.
8. Replace any previously removed cable ties.

PRECISION TIG 185



Return to Section TOC
Return to Master TOC

Return to Section TOC
Return to Master TOC

Return to Section TOC
Return to Master TOC

Return to Section TOC
Return to Master TOC

PRECISION TIG 185



POLARITY SWITCH REMOVAL AND REPLACEMENT PROCEDURE



WARNING

Service and repair should be performed by only Lincoln Electric factory trained personnel. Unauthorized repairs performed on this equipment may result in danger to the technician or machine operator and will invalidate your factory warranty. For your safety and to avoid electrical shock, please observe all safety notes and precautions detailed throughout this manual.

If for any reason you do not understand the test procedures or are unable to perform the test / repairs safely, contact the Lincoln Electric Service Department for electrical troubleshooting assistance before you proceed. Call 1-888-935-3877.

TEST DESCRIPTION

This procedure will aid the technician in the removal and replacement of the polarity switch.

MATERIALS NEEDED

3/8" Nutdriver

1/2" Wrench

7/16" Wrench

Phillips head screwdriver

5/64" Allen type Wrench

Needle nose pliers

Slot head screwdriver (2 required)

Wiring diagram

PRECISION TIG 185



POLARITY SWITCH REMOVAL AND REPLACEMENT PROCEDURE *(Continued)*

REMOVAL PROCEDURE

1. Remove the input power to the TIG 185 machine.
2. Using the 3/8" nutdriver remove the case wrap-around cover.
3. Using the 3/32" Allen type wrench remove the output control knob.
4. Using the Phillips head screwdriver remove the screw from the polarity switch handle.
5. With the 2 slot head screwdrivers carefully pry the polarity switch handle from the shaft.
6. Remove the five plastic snap rivets holding the name plate to the case front. These can be removed by gently prying at the rivet between the name plate and the case front.
7. Remove the name plate.
8. With the 1/2" wrench remove the "positive" flex lead from the polarity switch. See wiring diagram. Label lead and connection point for reassembly.
9. With the 1/2" wrench remove the "AC" flex lead from the polarity switch. This lead connects to the AC plate on the SCR bridge. See wiring diagram. Label lead and connection point for reassembly.
10. Using the 1/2" wrench remove the flex lead from the rear gang of the polarity switch. This lead connects to the D1 diode on the SCR bridge. See wiring diagram. Label lead and connection point for reassembly.
11. Using the 1/2" wrench remove the flat copper lead from the polarity switch. This lead connects to the high frequency transformer coil and the by-pass board. See wiring diagram. Label lead and connection point for reassembly.
12. Using the 1/2" wrench remove the other flat copper lead from the polarity switch. This lead connects to the lower terminal on the by-pass board and the "work" lead. See wiring diagram. Label lead and connection point for reassembly.
13. Using the 1/2" wrench remove the choke lead from the polarity switch. See wiring diagram. Label lead and connection point for reassembly.
14. With the 1/2" wrench remove the X1 secondary lead from the polarity switch. See wiring diagram. Label lead and connection point for reassembly.
15. With the 7/16" wrench remove the two nuts and washers that hold the polarity switch to the front panel.
16. Carefully rotate the polarity switch assembly to gain access to the micro-switch.
17. Carefully unsolder the two leads (#311 and #312) from the micro-switch located on the polarity switch assembly. See wiring diagram. Label leads and connection points for reassembly.
18. Carefully remove the polarity switch assembly from the machine.

PRECISION TIG 185



POLARITY SWITCH REMOVAL AND REPLACEMENT PROCEDURE *(Continued)*

REPLACEMENT PROCEDURE

1. Carefully position the new polarity switch in position on the front panel. Make certain the micro-switch is assembled to the polarity switch correctly.
2. Solder leads #311 and #312 to the micro -switch.
3. Assemble and tighten the two nuts and washers that hold the polarity switch to the front panel.
4. Assemble the X1 secondary lead to the polarity switch. Make certain washers are in place and the nut is tight.
5. Assemble the choke lead to the polarity switch. Make certain washers are in place and the nut is tight.
6. Assemble the flat copper leads to the polarity switch. Make certain they are connected to the proper terminals and the nuts are tightened.
7. Assemble the flex lead from diode D1 to the rear gang of the polarity switch. Make certain washers are in place and the nut is tight.
8. Assemble the flex lead from the AC bridge plate to the polarity switch. Make certain washers are in place and the nut is tight.
9. Assemble the "positive" flex lead to the polarity switch. Make certain washers are in place and the nut is tight.
10. Clear the leads and check for "shorted" or "grounded" leads.
11. Position the name plate and fasten to the front with the previously removed snap rivets.
12. Assemble the polarity switch handle in place with the Phillips head screw and check for correct switch operation.
13. Using the Allen type wrench replace the output control knob.
14. Replace the case wrap-around cover.

Return to Section TOC
Return to Master TOC

Return to Section TOC
Return to Master TOC

Return to Section TOC
Return to Master TOC

Return to Section TOC
Return to Master TOC

PRECISION TIG 185



HIGH VOLTAGE TRANSFORMER REMOVAL AND REPLACEMENT PROCEDURE



WARNING

Service and repair should be performed by only Lincoln Electric factory trained personnel. Unauthorized repairs performed on this equipment may result in danger to the technician or machine operator and will invalidate your factory warranty. For your safety and to avoid electrical shock, please observe all safety notes and precautions detailed throughout this manual.

If for any reason you do not understand the test procedures or are unable to perform the test / repairs safely, contact the Lincoln Electric Service Department for electrical troubleshooting assistance before you proceed. Call 1-888-935-3877.

TEST DESCRIPTION

This procedure will aid the technician in the removal and replacement of the high voltage transformer.

MATERIALS NEEDED

3/8" Nutdriver

Phillips head screwdriver

Needle nose pliers

Wire cutters

PRECISION TIG 185



HIGH VOLTAGE TRANSFORMER REMOVAL AND REPLACEMENT PROCEDURE *(Continued)*

REMOVAL PROCEDURE

1. Remove input power to the TIG 185 machine.
2. Using the 3/8" nutdriver remove the case wrap-around cover.
3. With the needle nose pliers remove the two secondary leads from the quick-connects on the high frequency arc starter board assembly. See Figure F.11.
4. Disconnect the in-line splice quick connect from one primary lead to lead #231A. Cut any necessary cable ties.
5. Remove the lead splice from the other primary lead that is connected to lead #236 and the C4 capacitor. See wiring diagram. Cut any necessary cable ties.
6. Using the phillips head screwdriver remove the front mounting screws from the base of the high voltage transformer. Take note of insulator placement for reassembly. NOTE: On some machines the mounting screw configuration may be different.
7. With phillips head screwdriver loosen the two rear mounting screws.
8. Carefully slide the transformer forward and remove from the TIG 185 machine.

FIGURE F.11 SECONDARY LEADS AT HIGH FREQUENCY STARTER BOARD

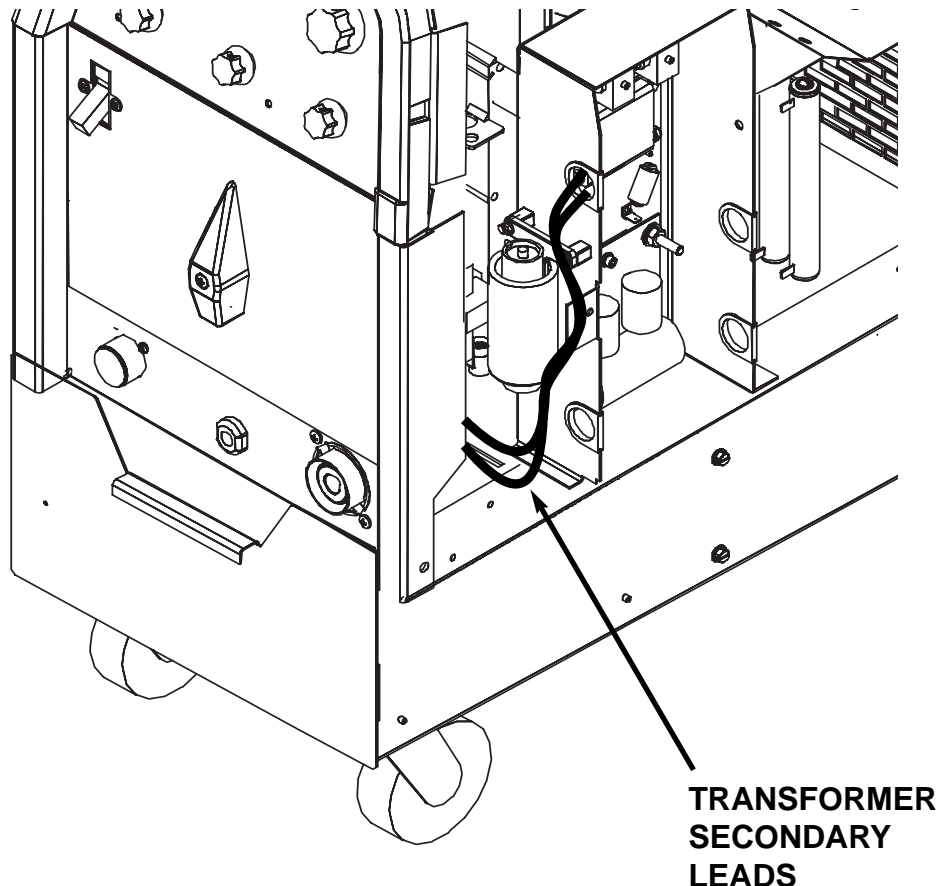

**TRANSFORMER
SECONDARY
LEADS**

PRECISION TIG 185



HIGH VOLTAGE TRANSFORMER REMOVAL AND REPLACEMENT PROCEDURE *(Continued)*

REPLACEMENT PROCEDURE

- Carefully position the new high voltage transformer in place in the two rear mounting insulators. See Figure F.12.
- Install the front mounting insulators and mounting screw.
- Using the phillips head screwdriver tighten all four mounting screws making certain the insulators are positioned correctly.
- Reconnect the two primary leads.
- Reconnect the two secondary leads to the high frequency arc starter board assembly.
- Replace any previously removed cable ties.
- Replace the case wrap-around cover.

FIGURE F.12 HIGH VOLTAGE TRANSFORMER MOUNTING INSULATORS

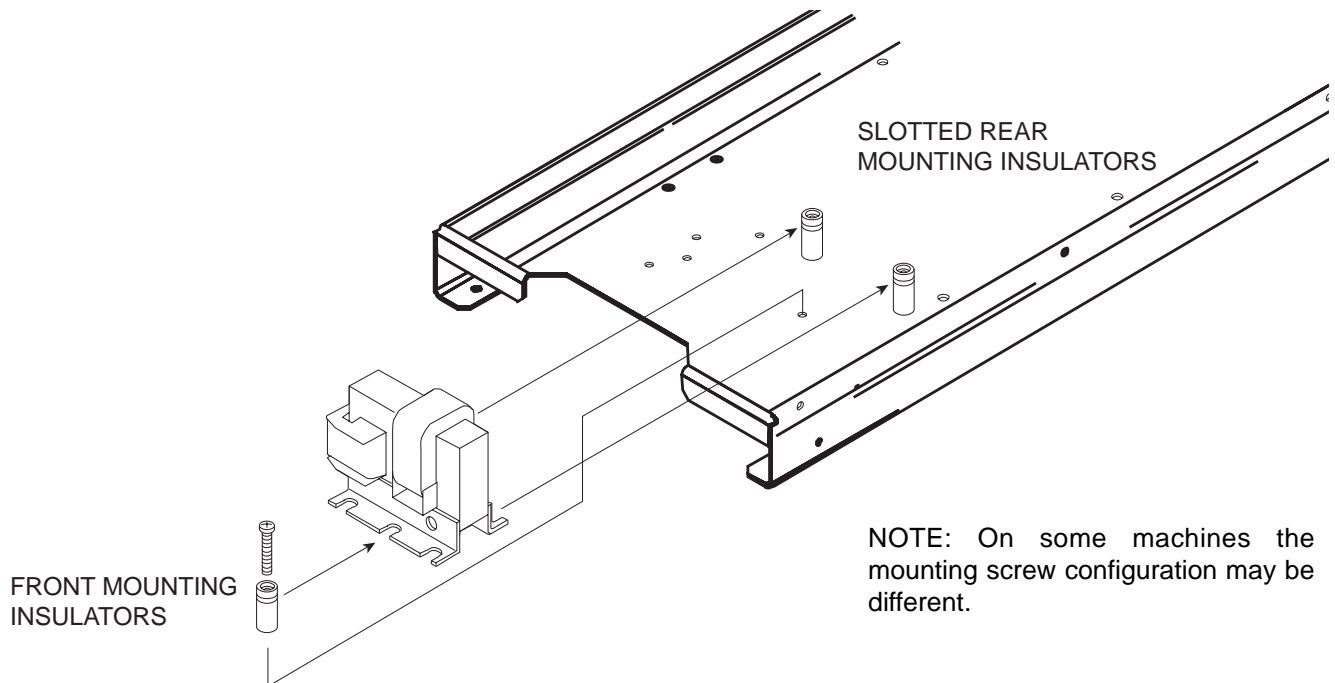

Return to Section TOC
Return to Master TOC

Return to Section TOC
Return to Master TOC

Return to Section TOC
Return to Master TOC

Return to Section TOC
Return to Master TOC

PRECISION TIG 185



MAIN TRANSFORMER AND OUTPUT CHOKE ASSEMBLY REMOVAL AND REPLACEMENT PROCEDURE



WARNING

Service and repair should be performed by only Lincoln Electric factory trained personnel. Unauthorized repairs performed on this equipment may result in danger to the technician or machine operator and will invalidate your factory warranty. For your safety and to avoid electrical shock, please observe all safety notes and precautions detailed throughout this manual.

If for any reason you do not understand the test procedures or are unable to perform the test / repairs safely, contact the Lincoln Electric Service Department for electrical troubleshooting assistance before you proceed. Call 1-888-935-3877.

TEST DESCRIPTION

This procedure will aid the technician in the removal and replacement of the main transformer and choke assembly.

MATERIALS NEEDED

3/8" Nutdriver

1/2" Wrench

Wire cutters

MAIN TRANSFORMER AND OUTPUT CHOKE ASSEMBLY REMOVAL AND REPLACEMENT PROCEDURE *(Continued)*

REMOVAL PROCEDURE

1. Remove input power to the TIG 185 machine.
2. Perform the ***SCR Bridge Assembly Removal Procedure***.
3. Unsolder the two 115VAC leads and leads B231 and B232 from the main transformer leads. Label leads for reassembly. See wiring diagram.
4. Unsolder leads W201 and W204 from the main transformer leads. Label leads for reassembly. See wiring diagram.
5. Unsolder leads R209 and U210 from the main transformer leads. Label leads for reassembly. See wiring diagram.
6. Using the 1/2" wrench remove the shunt assembly from the choke lead.
7. With the 3/8" wrench remove the H1, H2 or H3 lead from the input power switch. See wiring diagram. Label the leads and connection points for reassembly. Cut any necessary cable ties.
8. Remove plug J3 from the control board and push through the interior divider panel.
9. Using the 1/2" wrench remove the choke lead from the polarity switch. See wiring diagram. Label lead and connection point for reassembly.
10. With the 1/2" wrench remove the X1 secondary lead from the polarity switch. See wiring diagram. Label lead and connection point for reassembly.
11. With the 1/2" wrench remove the four nuts and lock washers from the transformer mounting bolts at the base of the machine.
12. Carefully hoist the transformer/choke assembly clear of the base. Clear all leads.

MAIN TRANSFORMER AND OUTPUT CHOKE ASSEMBLY REMOVAL AND REPLACEMENT PROCEDURE *(Continued)*

REPLACEMENT PROCEDURE

1. Position the new transformer/choke assembly onto the base and mounting bolts.
2. Assemble the four nuts and washers to the mounting bolts on the base of the machine.
3. Assemble the X1 secondary lead to the polarity switch.
4. Assemble the choke lead to the polarity switch.
5. Install the J3 plug into the control board.
6. Assemble the H1, H2 or H3 lead onto the input power switch. Insulate and secure the unused lead (H2 or H3).
7. Assemble the shunt assembly to the choke lead.
8. Solder leads R209 and U210 to the main transformer leads. See wiring diagram. Insulate connections.
9. Solder leads W201 and W204 to the main transformer leads. See wiring diagram. Insulate connections.
10. Solder the two 115VAC leads and leads B231 and B232 to the main transformer leads. See wiring diagram. Insulate connections.
11. Replace any previously removed cable ties. Clear leads and check for "shorts" or "grounds".
12. Perform the **SCR Bridge Assembly Replacement Procedure**.

Return to Section TOC
Return to Master TOC

Return to Section TOC
Return to Master TOC

Return to Section TOC
Return to Master TOC

Return to Section TOC
Return to Master TOC

PRECISION TIG 185



RETEST AFTER REPAIR

Should a machine under test be rejected for any reason requiring the removal of any mechanical part that could affect the machine's electrical characteristics, or if any electrical components are repaired or replaced, the machine must be retested.

INPUT IDLE AMPS	
Input Volts/Hertz	Maximum Idle Amps
208/60 230/60	2.50 Amps 3.00 Amps
OPEN CIRCUIT VOLTAGES	
Stick Mode OCV	AC 70 - 80VAC DC 55 - 65VDC
TIG Mode OCV	AC 70 - 80VAC DC 60 - 70VDC
MAXIMUM ACCEPTABLE OUTPUT VOLTAGE - AT MINIMUM OUTPUT SETTINGS	
DC TIG Mode	6 Amps @ 12 Volts
MINIMUM ACCEPTABLE OUTPUT VOLTAGE - AT MAXIMUM OUTPUT SETTINGS	
DC TIG Mode	200 Amps @ 29 Volts

RECOMMENDED METERS FOR MACHINE OUTPUT TESTS

VOLTMETER: AC and DC True RMS Meter - Fluke 8922A or equivalent

AMMETER: Columbia Type AX AC or DC Tong Ammeter

IMPORTANT: IF OTHER TYPE METERS ARE USED RESULTS MAY NOT BE ACCURATE.

PRECISION TIG 185



Return to Section TOC
Return to Master TOC

Return to Section TOC
Return to Master TOC

Return to Section TOC
Return to Master TOC

Return to Section TOC
Return to Master TOC

PRECISION TIG 185



TABLE OF CONTENTS - ELECTRICAL DIAGRAMS SECTION -

Electrical DiagramsSection G

Wiring Diagram (G4549)G-2

Entire Machine Schematic (G4588)G-3

Control PC Board Schematic (G4550-1B4-1)G-4

Control PC Board Schematic (G4550-1B4-2)G-5

Control PC Board Schematic (G4550-1B4-3)G-6

Control PC Board Assembly (G4551-1)G-7

Return to Master TOC

Return to Master TOC

Return to Master TOC

Return to Master TOC

WIRING DIAGRAM - ENTIRE MACHINE - (G4549)

Return to Section TOC
Return to Master TOC

Return to Section TOC
Return to Master TOC

Return to Section TOC
Return to Master TOC

Return to Section TOC
Return to Master TOC

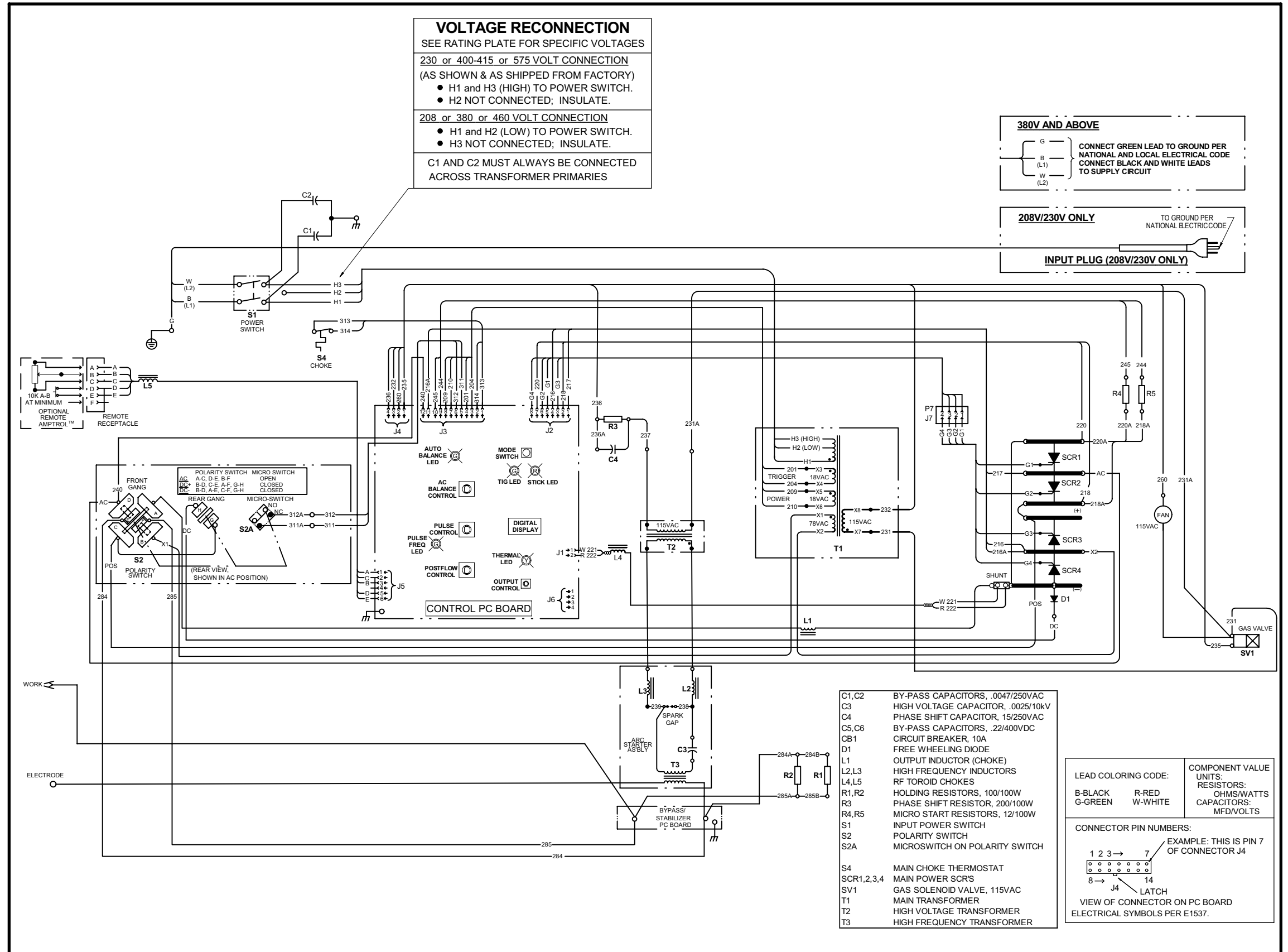

NOTE: This diagram is for reference only. It may not be accurate for all machines covered by this manual. The wiring diagram specific to your code is pasted inside one of the enclosure panels of your machine.

SCHEMATIC - ENTIRE MACHINE - (G4588)

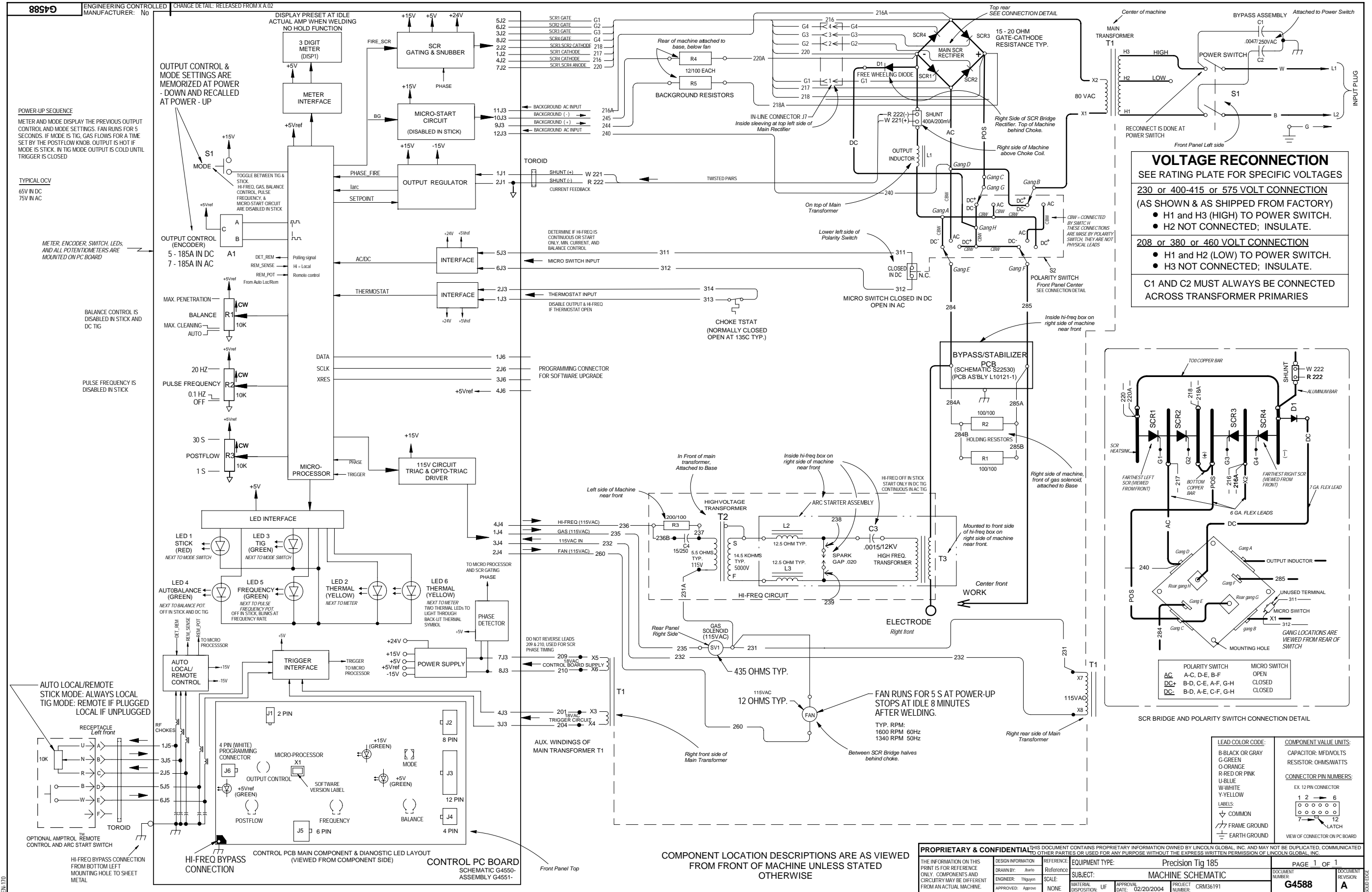

VOLTAGE RECONNECTION
SEE RATING PLATE FOR SPECIFIC VOLTAGES

230 or 400-415 or 575 VOLT CONNECTION (AS SHOWN & AS SHIPPED FROM FACTORY)

- H1 and H3 (HIGH) TO POWER SWITCH.
- H2 NOT CONNECTED; INSULATE.

208 or 380 or 460 VOLT CONNECTION

- H1 and H2 (LOW) TO POWER SWITCH.
- H3 NOT CONNECTED; INSULATE.

C1 AND C2 MUST ALWAYS BE CONNECTED ACROSS TRANSFORMER PRIMARIES

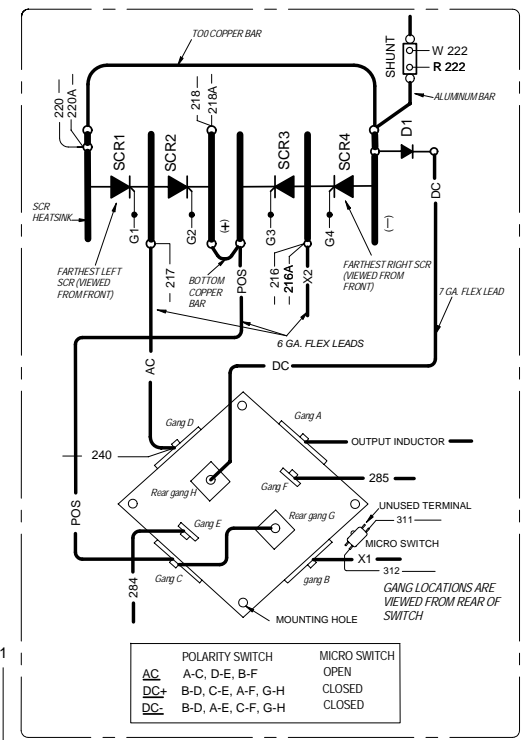

NOTE: This diagram is for reference only. It may not be accurate for all machines covered by this manual.

SCHEMATIC - CONTROL PC BOARD - (G4550-1B4-1)

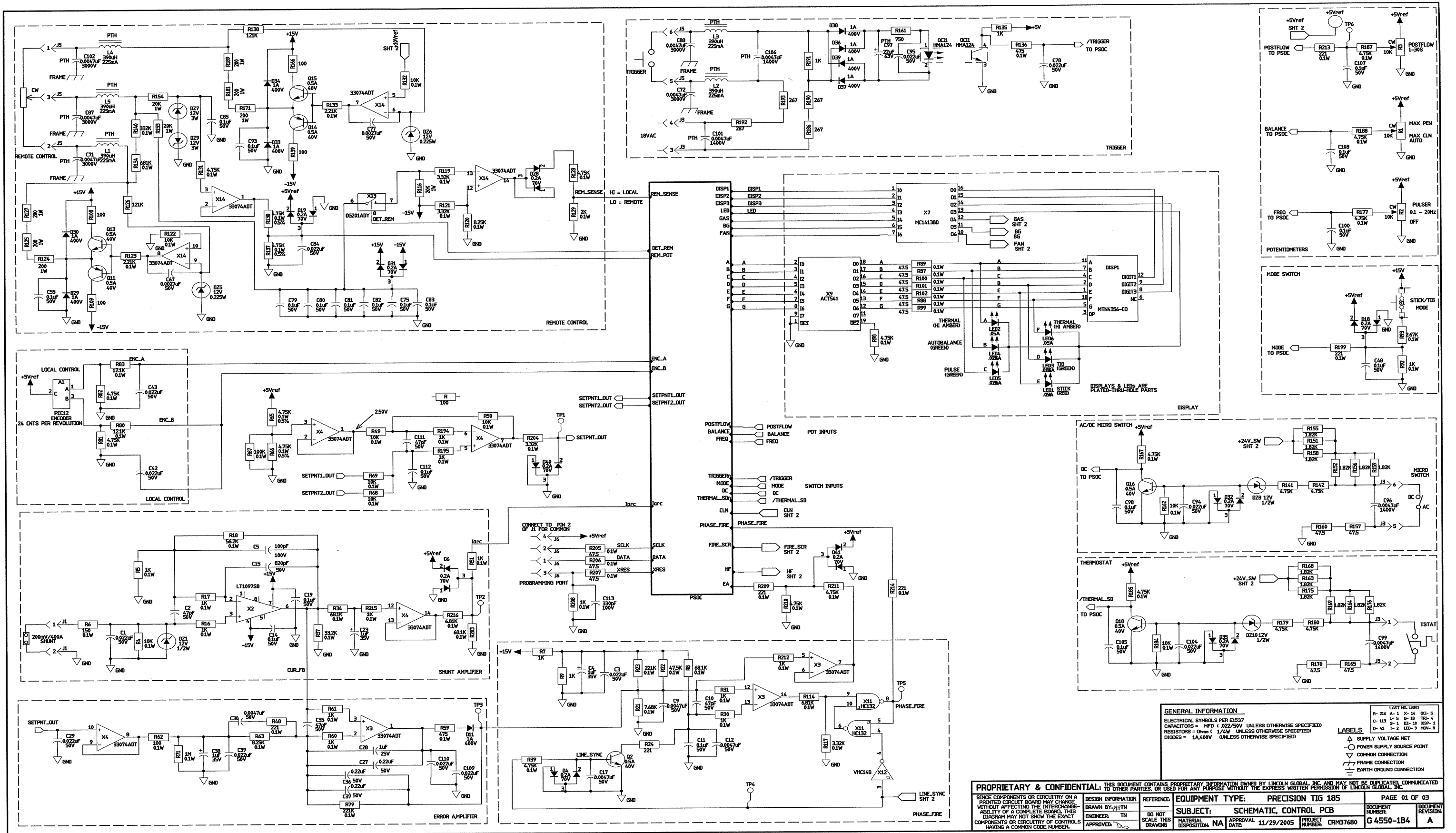

GENERAL INFORMATION

ELECTRICAL SYMBOLS PER IEEE
 CAPACITORS = MFD 0.22/50V (UNLESS OTHERWISE SPECIFIED)
 RESISTORS = Ohms (1/4W (UNLESS OTHERWISE SPECIFIED)
 DIODES = 1A, 400V (UNLESS OTHERWISE SPECIFIED)

PROPRIETARY & CONFIDENTIAL: THIS DOCUMENT CONTAINS PROPRIETARY INFORMATION OWNED BY LINCOLN GLOBAL, INC AND MAY NOT BE DUPLICATED, COMMUNICATED OR USED FOR ANY PURPOSE WITHOUT THE EXPRESS WRITTEN PERMISSION OF LINCOLN GLOBAL, INC.

DESIGN INFORMATION DRAWN BY: JHTN ENGINEER: TN APPROVED: [Signature]	REFERENCE: DO NOT SCALE THIS DRAWING	EQUIPMENT TYPE: PRECISION TIG 185	PAGE 01 OF 03
SUBJECT: SCHEMATIC, CONTROL PCB		MATERIAL DISPOSITION: NA APPROVAL DATE: 11/29/2005 PROJECT NUMBER: CRH37680	DOCUMENT NUMBER: G 4550-1B4 REVISION: A

NOTE: This diagram is for reference only. It may not be accurate for all machines covered by this manual.



SCHEMATIC - CONTROL P.C. BOARD - (G4550-1B4-2)

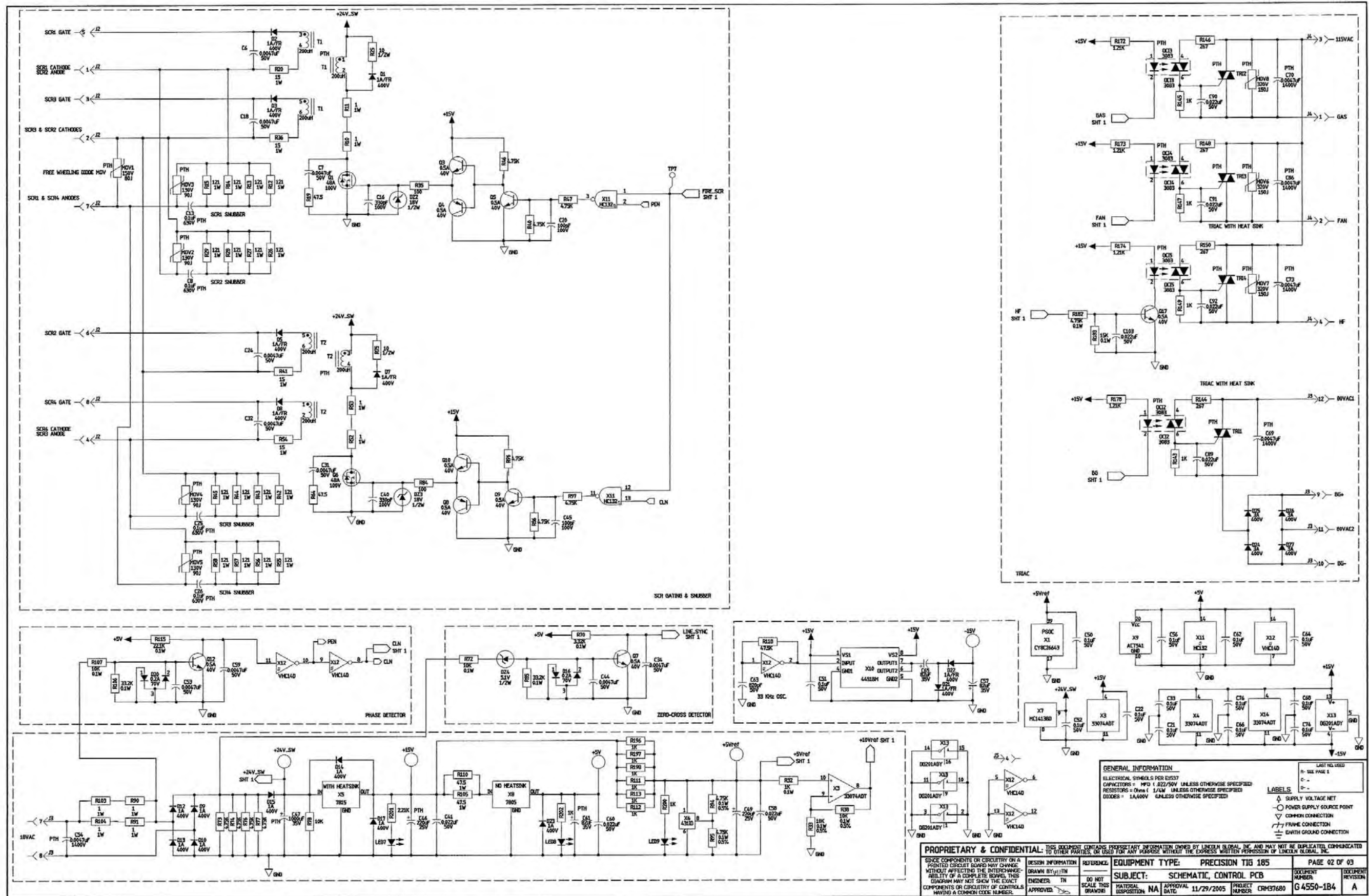

NOTE: This diagram is for reference only. It may not be accurate for all machines covered by this manual.

Return to Section TOC

Return to Section TOC

Return to Section TOC

Return to Section TOC

Return to Master TOC

Return to Master TOC

Return to Master TOC

Return to Master TOC

SCHEMATIC - CONTROL P.C. BOARD - (G4550-1B4-3)

Return to Section TOC
Return to Master TOC

Return to Section TOC
Return to Master TOC

Return to Section TOC
Return to Master TOC

Return to Section TOC
Return to Master TOC

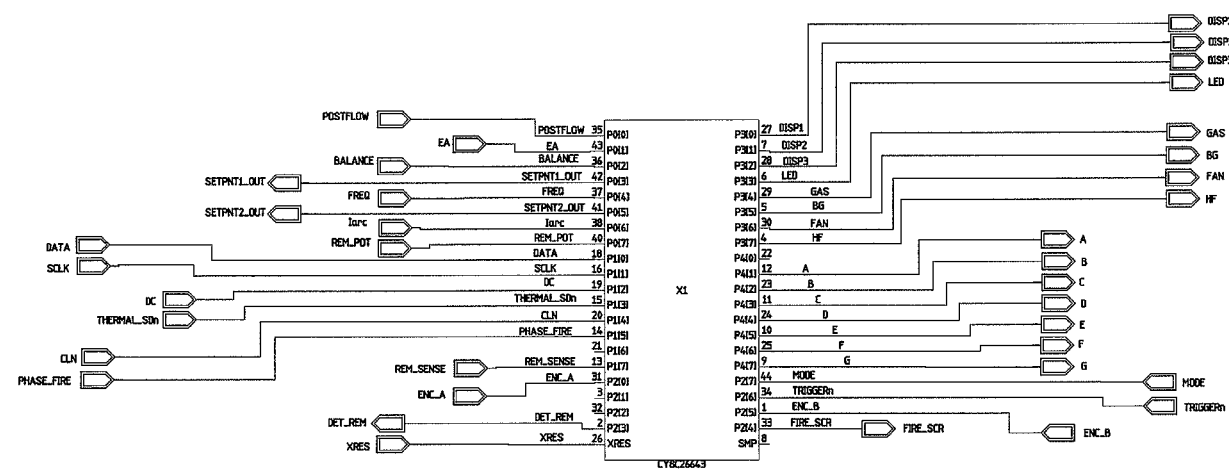

GENERAL INFORMATION		LAST NO. USED
ELECTRICAL SYMBOLS PER EIS37		R -
CAPACITORS = MFD (.022/50V UNLESS OTHERWISE SPECIFIED)		C -
RESISTORS = OHMS (1/4W UNLESS OTHERWISE SPECIFIED)		D -
DIODES = 1A/400V UNLESS OTHERWISE SPECIFIED		
LABELS		
▲ SUPPLY VOLTAGE NET		
○ POWER SUPPLY SOURCE POINT		
▽ COMMON CONNECTION		
▬ FRAME CONNECTION		
⊥ EARTH GROUND CONNECTION		

PROPRIETARY & CONFIDENTIAL: THIS DOCUMENT CONTAINS PROPRIETARY INFORMATION OWNED BY LINCOLN GLOBAL, INC. AND MAY NOT BE DUPLICATED, COMMUNICATED TO OTHER PARTIES, OR USED FOR ANY PURPOSE WITHOUT THE EXPRESS WRITTEN PERMISSION OF LINCOLN GLOBAL, INC.			
DESIGN INFORMATION	REFERENCE:	EQUIPMENT TYPE:	PAGE 03 OF 03
DRAWN BY: JHTN	DO NOT SCALE THIS DRAWING	SUBJECT:	PRECISION TIG 185
ENGINEER: TN	APPROVED: [Signature]	MATERIAL DISPOSITION: NA	SCHEMATIC, PSQC
		APPROVAL DATE: 11/29/2005	PROJECT NUMBER: CRM37680
			DOCUMENT NUMBER: G4550-1B4
			DOCUMENT REVISION: A

NOTE: This diagram is for reference only. It may not be accurate for all machines covered by this manual.



SVM ERROR REPORTING FORM

We need to know if there are errors in our manuals. We also value any suggestions as to additional tests or procedures that would make this SVM a better tool for you.

If you discover new or different "Problems or Symptoms" that are not covered in the three column troubleshooting chart, please share this information with us. Please include the machine's code number and how the problem was resolved.

Thank You,
Technical Services Group
Lincoln Electric Co.
22801 St. Clair Ave.
Cleveland, Ohio 44117-1199

FAX 216-481-2309

SVM Number _____

Page Number if necessary _____

Your Company _____

Your Name _____

Please give detailed description below:
