

# RANGER 305D CE (EUROPE) MACHINE SCHEMATIC L12038 REV-A

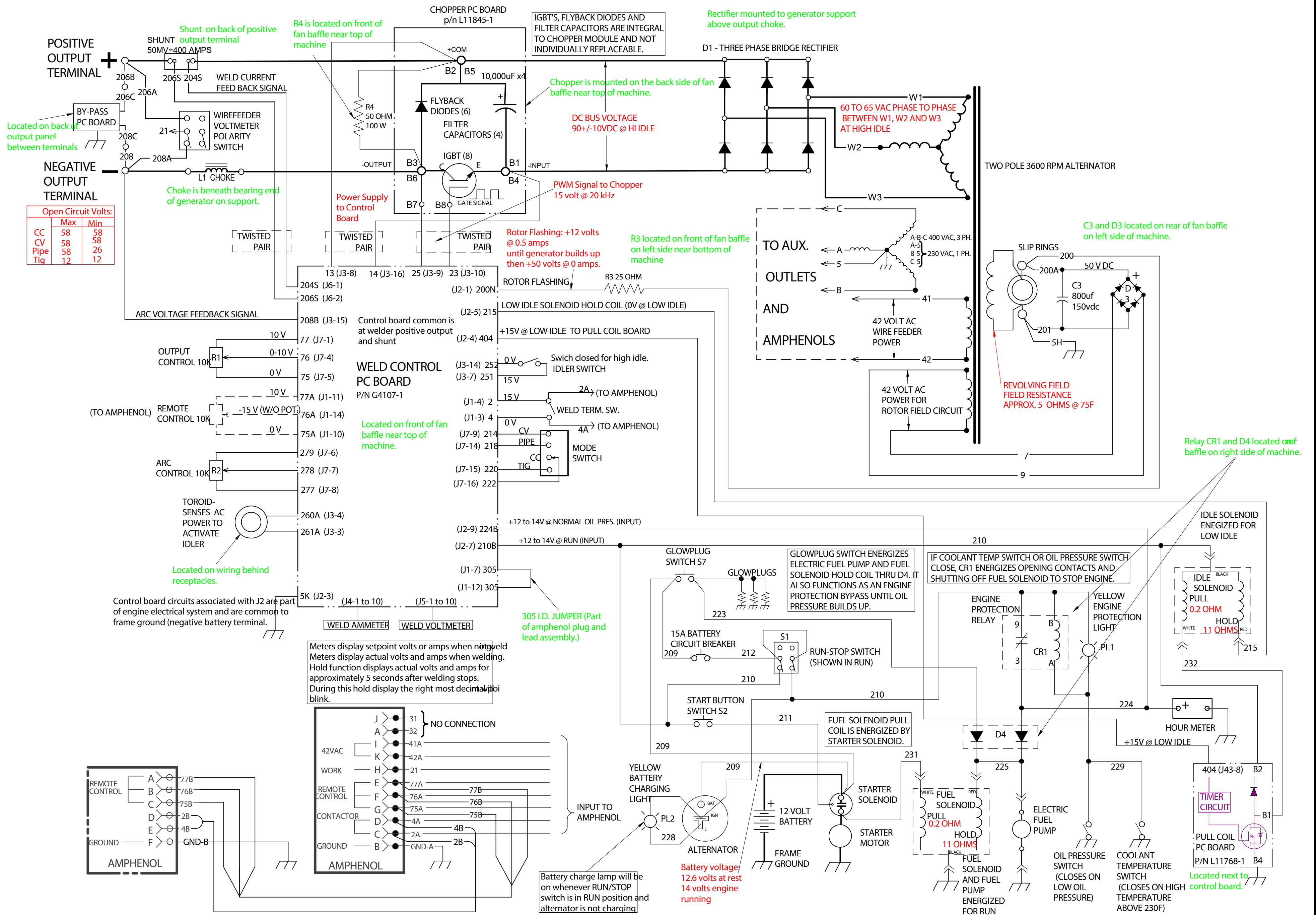

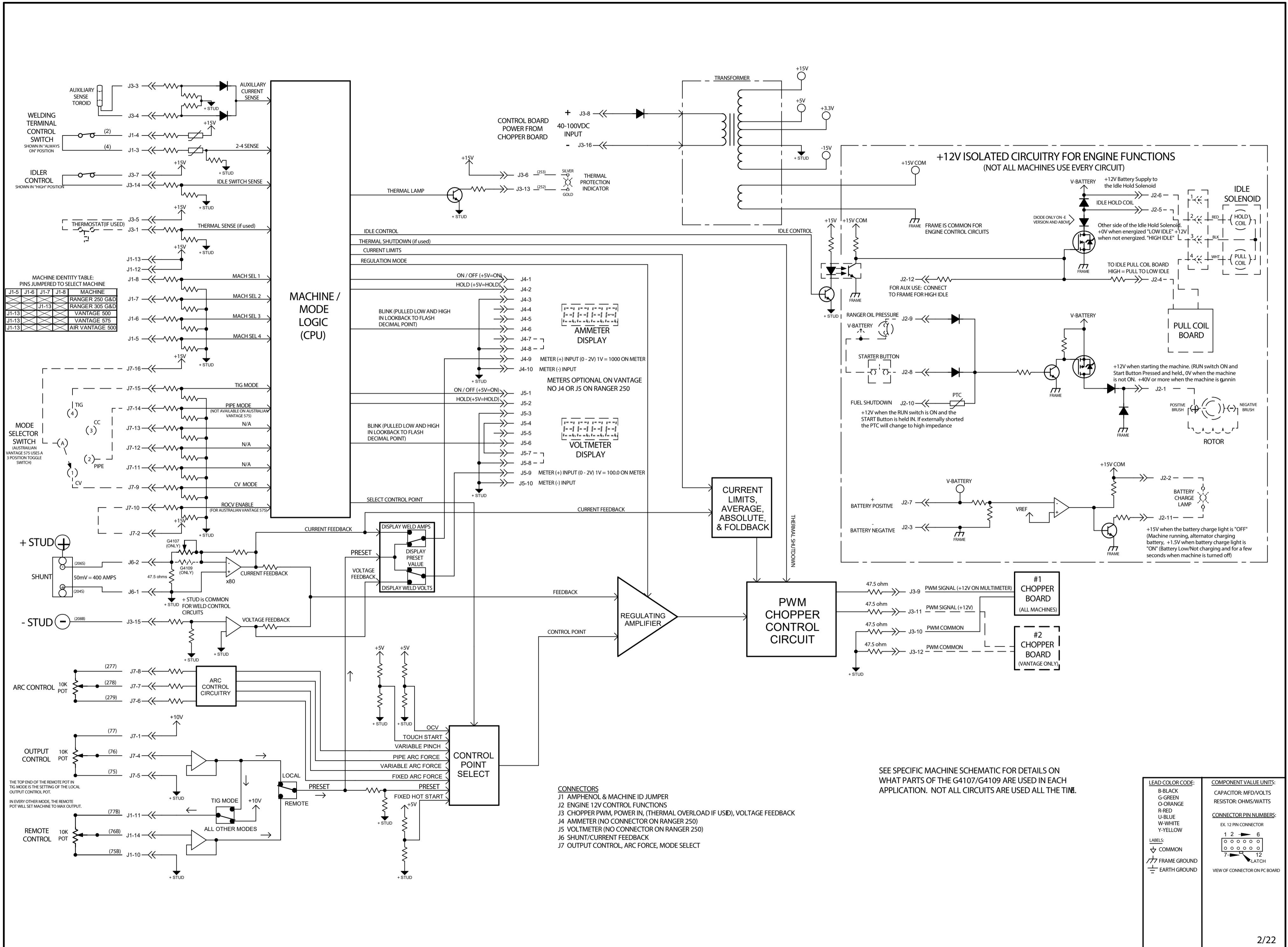

**MACHINE IDENTITY TABLE:**  
PINS JUMPED TO SELECT MACHINE

J1-5	J1-6	J1-7	J1-8	MACHINE
X	X	X	X	RANGER 250 G&D
X	X	X	X	RANGER 305 G&D
X	X	X	X	VANTAGE 900
X	X	X	X	VANTAGE 575
X	X	X	X	AIR VANTAGE 500

**LEAD COLOR CODE:**

- B-BLACK
- G-GREEN
- O-ORANGE
- R-RED
- U-BLUE
- W-WHITE
- Y-YELLOW

**COMPONENT VALUE UNITS:**

CAPACITOR: MFD/VOLTS  
RESISTOR: OHMS/WATTS

**CONNECTOR PIN NUMBERS:**

EX 12 PIN CONNECTOR

```

1 2 3 4 5 6
| | | | | |
7 8 9 10 11 12
    
```

VIEW OF CONNECTOR ON PCB BOARD