

## 87501

### REPLACEMENT PARTS LIST CENTURY 220/50/25/2 AMP CHARGER MODEL 141-269

ITEM	DESCRIPTION	PART NUMBER	ITEM	DESCRIPTION	PART NUMBER
1	BASE	440-320-010	8	RECTIFIER ASSEMBLY	865-682-666
2	(2) HUBS	068-013-666	9	CIRCUIT BREAKER	246-211-666
3	(2) WHEELS & (2) HUBS	413-044-666	10	TRANSFORMER	865-762-888
4	AXLE & (2) HUBS	413-043-666	11	TIMER	246-273-666
5	POWER CORD W/STRAIN RELIEF	248-195-666	12	ROTARY SWITCH	246-057-666
6	POSITIVE CLAMP W/CABLE & STRAIN RELIEF	238-260-666	13	FRONT PANEL	440-264-080
7	NEGATIVE CLAMP W/CABLE & STRAIN RELIEF	238-261-666	14	CONTROL KNOB	246-041-666
-	POS & NEG CLAMPS W/GRIPS	249-066-666	15	AMMETER	247-075-666
			16	FRONT FOOT	312-067-666
			17	COVER (NOT SHOWN)	440-256-060
			18	HANDLE (NOT SHOWN)	442-020-166

SERVICING SHOULD BE PERFORMED BY QUALIFIED SERVICE PERSONNEL.

FORM NO. 841-785-000

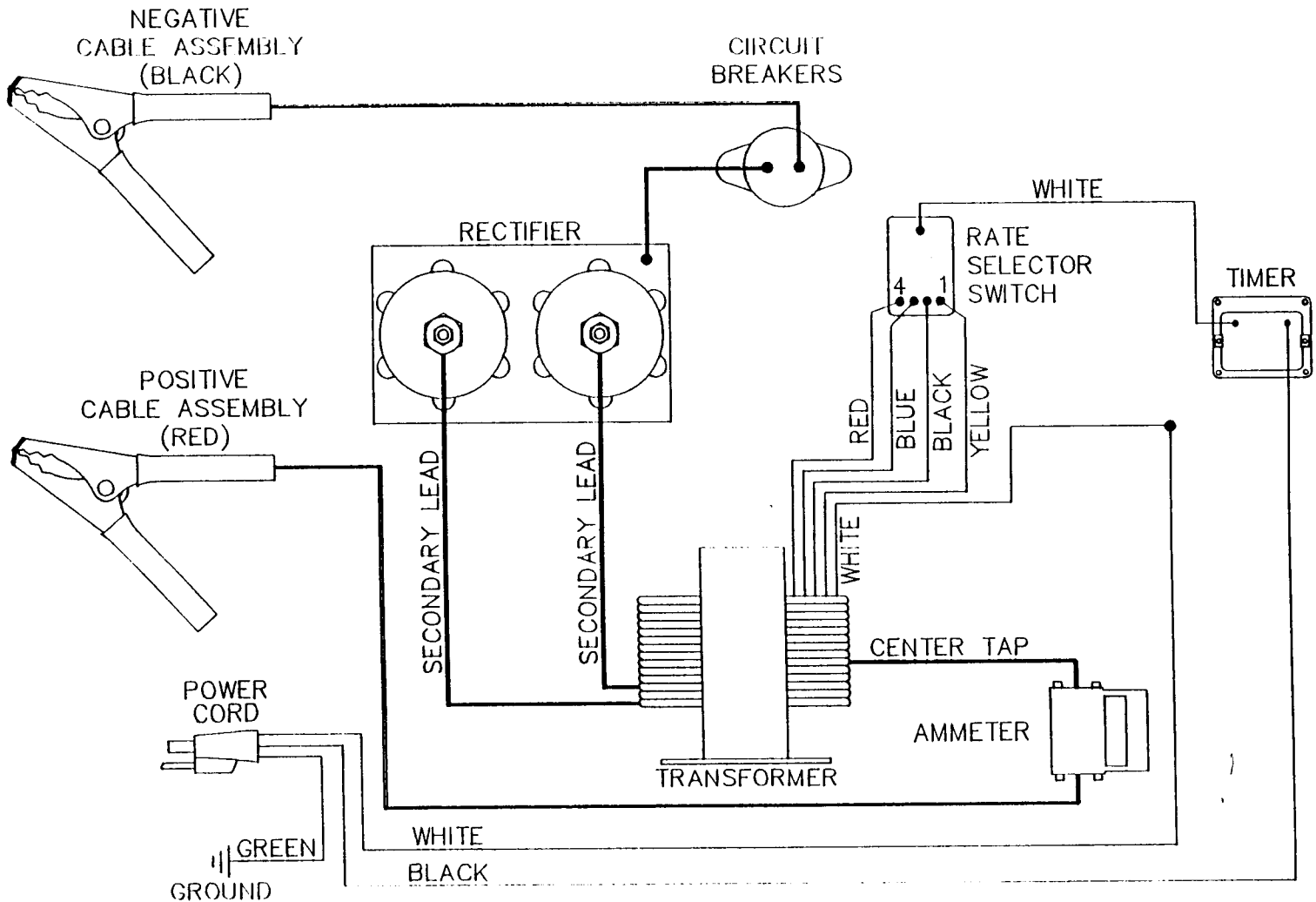

WIRING DIAGRAM