

# HELIX M4X

## LOW PROFILE ORBITAL AND FLAT TRACK WELD HEAD



### PRECISION TRACK-BASED WELDING WITH A LOW PROFILE HEAD

The HELIX® M4X™ orbital weld head extends the industry-proven high performance of the HELIX M series to a multitude of new applications. The weld head's low radial clearance enables digitally controlled precision welding in areas of limited space and physical constraints. In addition, the dramatically reduced axial clearance increases flexibility when setting up the track.

Operating on the Power Wave® platform, the HELIX M4X weld head delivers advanced multi-process capabilities and features a pivoting torch assembly that provides perpendicular height adjustment for greater control of the weld puddle. The on-board servo feeder precisely delivers wire across the full speed range for GMAW/FCAW and GTAW welding applications.

The HELIX M4X weld head can be quickly and easily clamped to an orbital or flat track and freely moved with the clutch disengaged to check alignment. Highly visible red color coding on all user adjustments and handles helps shorten the training period, and angle sensors permit advanced repeatability and automatic weld parameter changes for 5G pipe welding. Options for narrow-groove welding, motorized wire guides and remote viewing are available for higher-end applications.

For optimal orbital welding performance in every application and every space, make the rounds with the HELIX M4X orbital weld head.

#### Processes »

GMAW, FCAW, GTAW, HOT WIRE GTAW

#### Applications »

Fabrication, Power Generation, Pressure Vessels, Process Pipe

#### Input »



#### Product Number »

K52318-1 HELIX M4X Weld Head  
K52325-1 APEX® 30S M4X MIG Ready-Pak®\*  
K52326-1 APEX 30S M4X TIG Ready-Pak\*  
K52327-1 APEX 30S M4X Hot Wire TIG Ready-Pak\*  
\* Use -2 for CE Version

## KEY FEATURES

### Best-in-Class Performance

- Utilizing the latest in digital motor control technology, the HELIX M4X features consistent performance without the need for manual calibration at startup.
- APEX Auto Height, Auto Sector and Auto Path Technology provides advanced travel speed and true oscillation width/speed control that delivers repeatable welds with minimal setup.
- Automated features minimize operator training while increasing operator availability.

### Versatile Design

- Low radial clearance – 4.67 to 6.94 inches (119 - 176 mm) depending on the torch configuration.
- Water-cooled torches help eliminate overheating.
- Proven, versatile mechanism allows the weld head to be disengaged and repositioned with one easy motion.
- Interchangeable with HELIX M series family of weld heads.

## KEY ADJUSTMENT LOCATIONS

- Track Clamping Lever
- Clutch Release Lever
- On-Board Wire Feeder



Track Clamping Lever



Clutch Release Lever

- Universal Torch Dovetail Mount
- Torch Tilt Adjustment

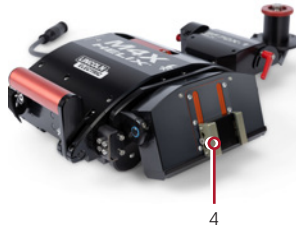

4



5

## CLEARANCE INFORMATION

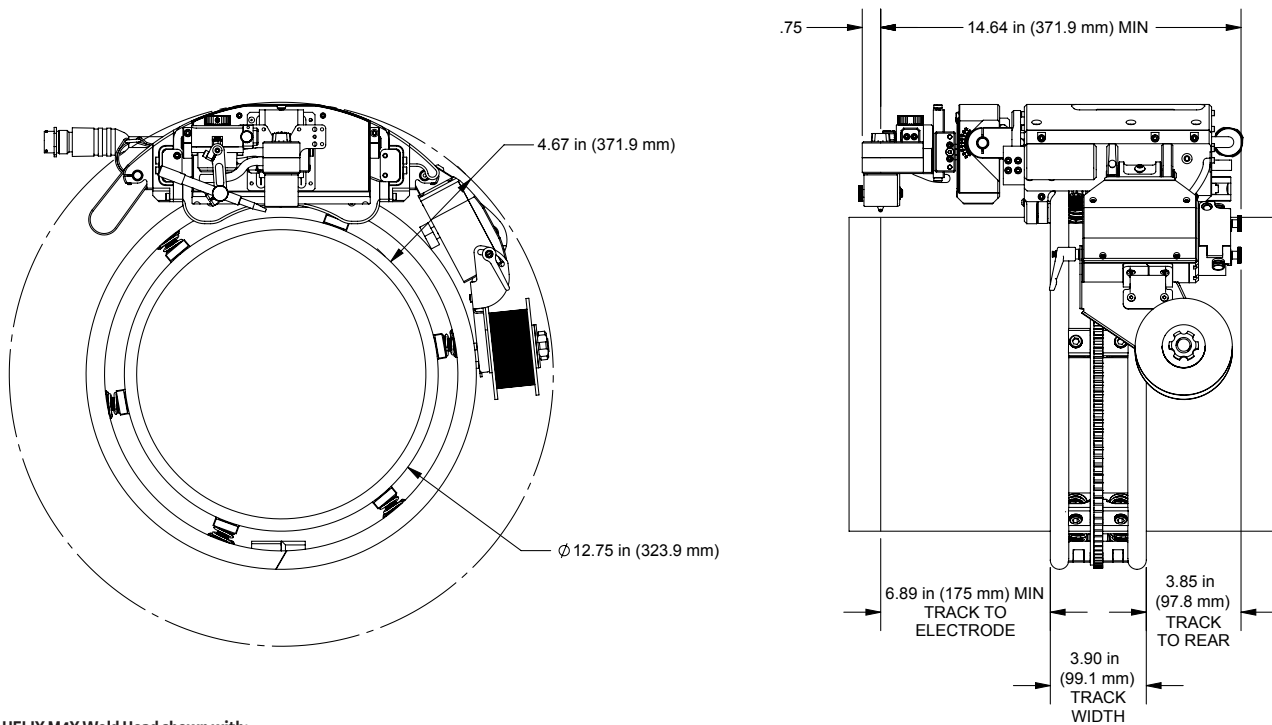

HELIX M4X Weld Head shown with:  
 K52319-1 Wire Feeder  
 K52322-25 GTAW Torch  
 K52324-1 Wire Manipulator

## CLEARANCE INFORMATION CONT.

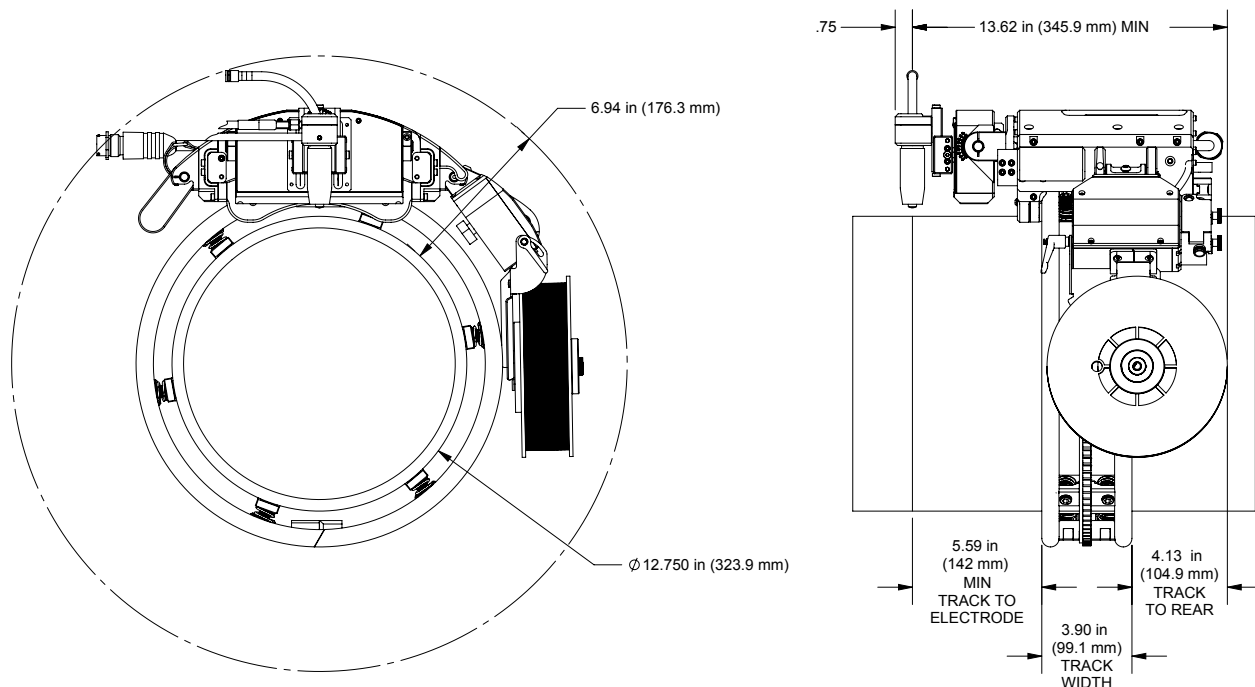

HELIX M4X Weld Head shown with:  
K52319-1 Wire Feeder  
K52320-25 GMAW/FCAW Torch

## MODELS & PACKAGES AVAILABLE



### K52318-1 HELIX M4X Weld Head

#### WHAT'S INCLUDED

- Weld Head with SF70X Feeder
- Pelican Case



### K52326-1 APEX 30S M4X TIG Ready-Pak

#### WHAT'S INCLUDED

- HELIX M4X Weld Head
- Power Wave S500
- APEX 30S
- CoolArc 55S
- APEX Pendant
- Torch with Control Cable
- System Cart



### K52325-1 APEX 30S M4X MIG Ready-Pak

#### WHAT'S INCLUDED

- HELIX M4X Weld Head
- Power Wave S500
- APEX 30S
- CoolArc® 55S
- APEX Pendant
- Torch with Control Cable
- System Cart



### K52327-1 APEX 30S M4X Hot Wire TIG Ready-Pak

#### WHAT'S INCLUDED

- HELIX M4X Weld Head
- Power Wave S500 (x2)
- APEX 30S
- CoolArc 55S
- Power Wave Advanced Module
- APEX Pendant
- Torch with Control Cable
- System Cart

## RECOMMENDED ACCESSORIES



K52107-25



K52320-25



K52322-25



KP52063-1



KP52064-1



KP52240-125



KP2747-1

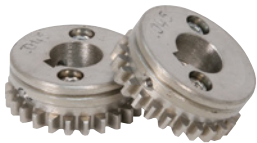

KP52079-045



K52244-045



K52000-18



K52090-1

DESCRIPTION	PRODUCT NUMBER	PROCESS
<b>CONTROL CABLES</b>		
Weld Head Control Cable 15 ft (4.6 m)	K52107-15	
Weld Head Control Cable 25 ft (7.62 m)	K52107-25	
Weld Head Control Cable 50 ft (15.24 m)	K52107-50	
<b>TORCHES</b>		
PTW-18MPL-500 Mechanized TIG Torch with Cam-Lock	K52320-25	GTAW
PTW-18MPL-500 Mechanized TIG Torch with Twist Mate	K52321-25	GTAW
Magnum® Pro 550 LP7 Mechanized with Cam-Lock	K52322-25	GMAW/FCAW
Magnum Pro 550 LP7 Mechanized with Twist Mate	K52323-25	GMAW/FCAW
<b>ONBOARD WIRE FEEDERS &amp; WIRE MANIPULATOR KITS</b>		
HELIX SF70X-1 Onboard Wire Feeder	K52319-1	GMAW/FCAW/GTAW
HELIX SF70X-2 Onboard Wire Feeder	K52319-2	GMAW/FCAW/GTAW
HELIX M4X Wire Manipulator -1	K52324-1	GTAW
HELIX M4X Wire Manipulator -2	K52324-2	GTAW
<b>PART &amp; ACCESSORIES - OTHER SIZES AVAILABLE</b>		
Caliber® Back Cap - Short, 17/18/26 Torches - 2/pack	KP4746-5	GTAW
Glass Cup - 1.281 in (32.5 mm) Long	KP52062-1	GTAW
Tungsten Adapter 1/8 in (3.2 mm)	KP52063-1	GTAW
Collet Body	KP52064-1	GTAW
Collet 1/8 in (3.2 mm)	KP52240-125	GTAW
Magnum Contact Tip - Tapered, 0.035 in (0.9 mm) - 10/pack	KP14T-35	GTAW
Magnum PRO Copper Plus™ 550A Contact Tips - 0.045 in (1.2 mm)	KP2745-045	GMAW/FCAW
Magnum PRO Diffuser - 550A, Thread-On	KP2747-1	GMAW/FCAW
Magnum PRO 550A Gas Nozzle - Thread-On, 5/8 in ID	KP2743-1-62R	GMAW/FCAW
Cable Liner 0.035-0.045 in (0.9-1.2 mm) 15 ft (4.6 m) (CUT TO LENGTH)	KP45-3545-15	GMAW/FCAW/GTAW
<b>DRIVE ROLL KITS - OTHER SIZES AVAILABLE</b>		
HELIX SF70A/SF70X Onboard Feeder Drive Roll Kit 0.035 in (0.9 mm)	KP52079-035	GMAW/GTAW
HELIX SF70A/SF70X Onboard Feeder Drive Roll Kit 0.045 in (1.1 mm)	KP52079-045	GMAW/GTAW
HELIX SF70A/SF70X Onboard Feeder Drive Roll Kit 0.045 in (1.1 mm) Cored Wire	KP52079-045C	FCAW
HELIX SF70A/SF70X Onboard Feeder Drive Roll Kit 0.052 in (1.4 mm) Cored Wire	KP52079-052C	FCAW
Inlet Outlet Guide Set Brass 0.030-0.045 in (0.8-1.1 mm)	K52244-045	GMAW/FCAW/GTAW
Inlet Outlet Guide Set Brass 0.052-1/16 in (1.4-1.6 mm)	K52244-062	GMAW/FCAW/GTAW
Inlet Outlet Guide Set SS 0.030-0.045 in (0.8-1.1 mm)	K52333-045	GMAW/FCAW/GTAW
Inlet Outlet Guide Set SS 0.052-1/16 in (1.4-1.6 mm)	K52333-062	GMAW/FCAW/GTAW
<b>HELIX TRACKS - LARGER SIZES AVAILABLE</b>		
HELIX Quick Release Track Ring 8 in (203.2 mm) - 4 Shoes	K52000-08	
HELIX Quick Release Track Ring 10 in (254 mm) - 4 Shoes	K52000-10	
HELIX Quick Release Track Ring 12 in (304.8 mm) - 6 Shoes	K52000-12	
HELIX Quick Release Track Ring 14 in (355.6 mm) - 6 Shoes	K52000-14	
HELIX Quick Release Track Ring 16 in (406.4 mm) - 6 Shoes	K52000-16	
HELIX Quick Release Track Ring 18 in (457.2 mm) - 8 Shoes	K52000-18	
HELIX Quick Release Track Ring 20 in (508 mm) - 8 Shoes	K52000-20	
HELIX Quick Release Track Ring 22 in (558.8 mm) - 8 Shoes	K52000-22	
HELIX Quick Release Track Ring 24 in (609.6 mm) - 8 Shoes	K52000-24	
HELIX Quick Release Track Ring 28 in (711.2 mm) - 5 Shoes	K52000-28	
HELIX Quick Release Track Ring 32 in (812.8 mm) - 5 Shoes	K52000-32	
HELIX Quick Release Track Ring 36 in (914.4 mm) - 6 Shoes	K52000-36	
HELIX Flat Track 48 in (1219.2 mm) with Magnetic Shoes	K52090-1	

## PRODUCT SPECIFICATIONS

Product Name	Product Number	Input Power	Input Current	Travel Speed in/min [cm/min]	Clearance - in (mm)		Oscillation Stroke in (mm)	Motorized Height Control Stroke	Lead/Lag Range	Torch Tilt		Dimensions H x W x D in (mm)
					Radial in. (mm)	Axial in. (mm)				In	Out	
HELIX M4X Weld Head	K52318-1	24V DC	9A max	0.10 - 100 [0.25 - 254]	GMAW/FCAW 6.94 [176] GTAW 4.67 [119]	GMAW/FCAW 13.62 [346] GTAW 14.64 [372]	3.50 [89]	1.90 [48.3]	+/- 15°	18° max	21° max	4.84 x 24.93 x 14.27 [123.0 x 633.2 x 362.4]



HELIX M4X Weld Head shown with:  
K52319-1 Wire Feeder  
K52322-25 GMAW/FCAW Torch



HELIX M4X Weld Head shown with:  
K52319-1 Wire Feeder  
K52320-25 GTAW Torch  
K52324-1 Wire Manipulator



IMAGE  
COMING  
SOON

HELIX M4X Weld Head shown with:  
K52319-1 and K52319-2 Wire Feeders  
K52320-25 GTAW Torch  
K52324-1 and K52324-2 Wire Manipulators

### CUSTOMER ASSISTANCE POLICY

The business of Lincoln Electric is manufacturing and selling high quality welding equipment, automated welding systems, consumables, cutting equipment and EV charging systems. Our challenge is to meet the needs of our customers, who are experts in their fields, and to exceed their expectations. On occasion, purchasers may ask Lincoln Electric for information or technical information about their use of our products. Our employees respond to inquiries to the best of their ability based on information and specifications provided to them by the customers and the knowledge they may have concerning the application. Our employees, however, are not in a position to verify the information provided or to evaluate the engineering requirements for the particular weldment, or to provide engineering advice in relation to a specific situation or application. Accordingly, Lincoln Electric does not warrant or guarantee or assume any liability with respect to such information or communications. Moreover, the provision of such information or technical information does not create, expand, or alter any warranty on our products. Any express or implied warranty that might arise from the information or technical information, including any implied warranty of merchantability or any warranty of fitness for any customers' particular purpose or any other equivalent or similar warranty is specifically disclaimed. Lincoln Electric is a responsive manufacturer, but the definition of specifications, and the selection and use of specific products sold by Lincoln Electric is solely within the control of, and remains the sole responsibility of the customer. Many variables beyond the control of Lincoln Electric affect the results obtained in applying these types of fabrication methods and service requirements.