

FILCORD i250 & i300

Spare Parts	1
Figure A: Machine Assembly	2
Figure B: Inside Machine Assembly	3
Figure C: Front Assembly	4
Electrical Schematic	5
CODE: 50621, 50622	5



Spare Parts

SP50621, SP50622REV02
09/2022

ASSEMBLY PAGE NAME			Machine Assembly	Machine Assembly	Machine Assembly	Miscellaneous Items		
CODE NO.:	W NO.:	FIGURE NO.:	A	B	C	-		
50621	W100000315	FILCORD i250	1	1	1	1		
50622	W100000316	FILCORD i300	2	2	2	2		

*items highlighted in bold are recommended spare parts

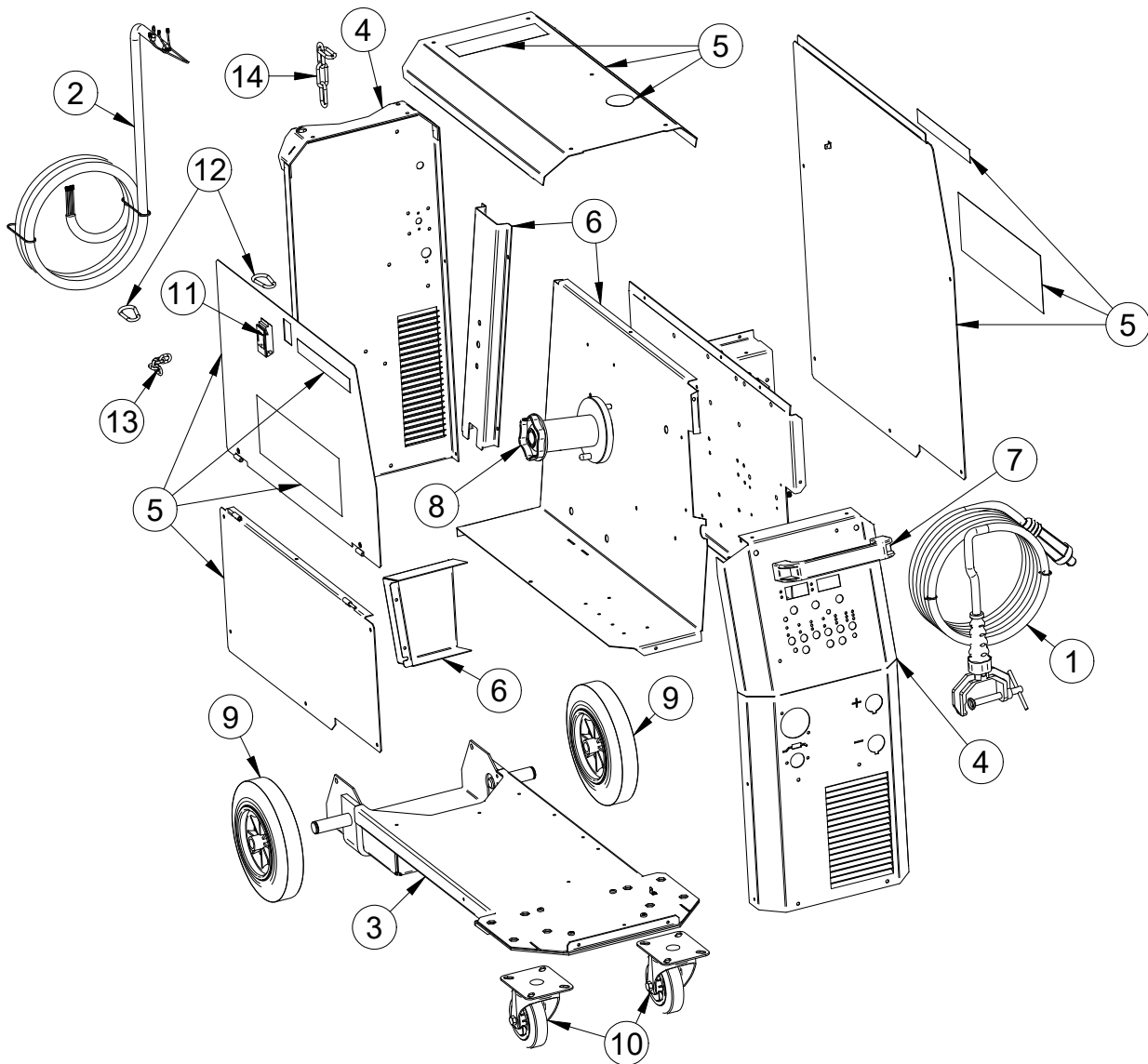

Figure A

Figure A: Machine Assembly

Item	Description	Part Number	QTY	1	2	3	4	5	6	7	
1	GROUND CABLE-3M-4	D-5578-176-4R	1	X	X						
2	MAIN INPUT CORD	R-5041-652-1R	1	X	X						
3	BASE ASSEMBLY	T-8040-148-1R	1	X	X						
4	FRONT AND REAR PANEL KIT	T-8040-149-1R	1	X	X						
5	SIDE PANEL KIT includes:	T-8040-150-2R	1	X	X						
	LEFT SIDE PANEL		1	X	X						
	UPPER SIDE PANEL		1	X	X						
	BOTTOM SIDE PANEL		1	X	X						
	TOP PLATE ASSEMBLY		1	X	X						
	FILCORD LABEL		2	X	X						
	SAF-FRO LABEL		2	X	X						
	LABEL		1	X	X						
	STICKER		1	X	X						
6	PARTITION KIT	T-8040-151-1R	1	X	X						
	PARTITION ASSEMBLY		1	X	X						
	BRACKET		1	X	X						
	COVER		1	X	X						
	LEXAN LABEL		1	X	X						
7	HANDLE BOTECA B226-180 M8	1361-598-186R	1	X	X						
8	WIRE SPOOL HUB	0744-000-335R	1	X	X						
9	WHEEL DIA-200	1029-660-201R	2	X	X						
10	TURNING WHEEL DIA-100	1029-660-101R	2	X	X						
11	DOOR LATCH PT,LF	0654-610-004R	1	X	X						
12	CLIP HOOK 5X50 K10347-PG	0652-410-006R	2	X	X						
13	CHAIN L=350MM	0652-410-004R	1	X	X						
14	CHAIN L=700MM	0652-410-003R	1	X	X						

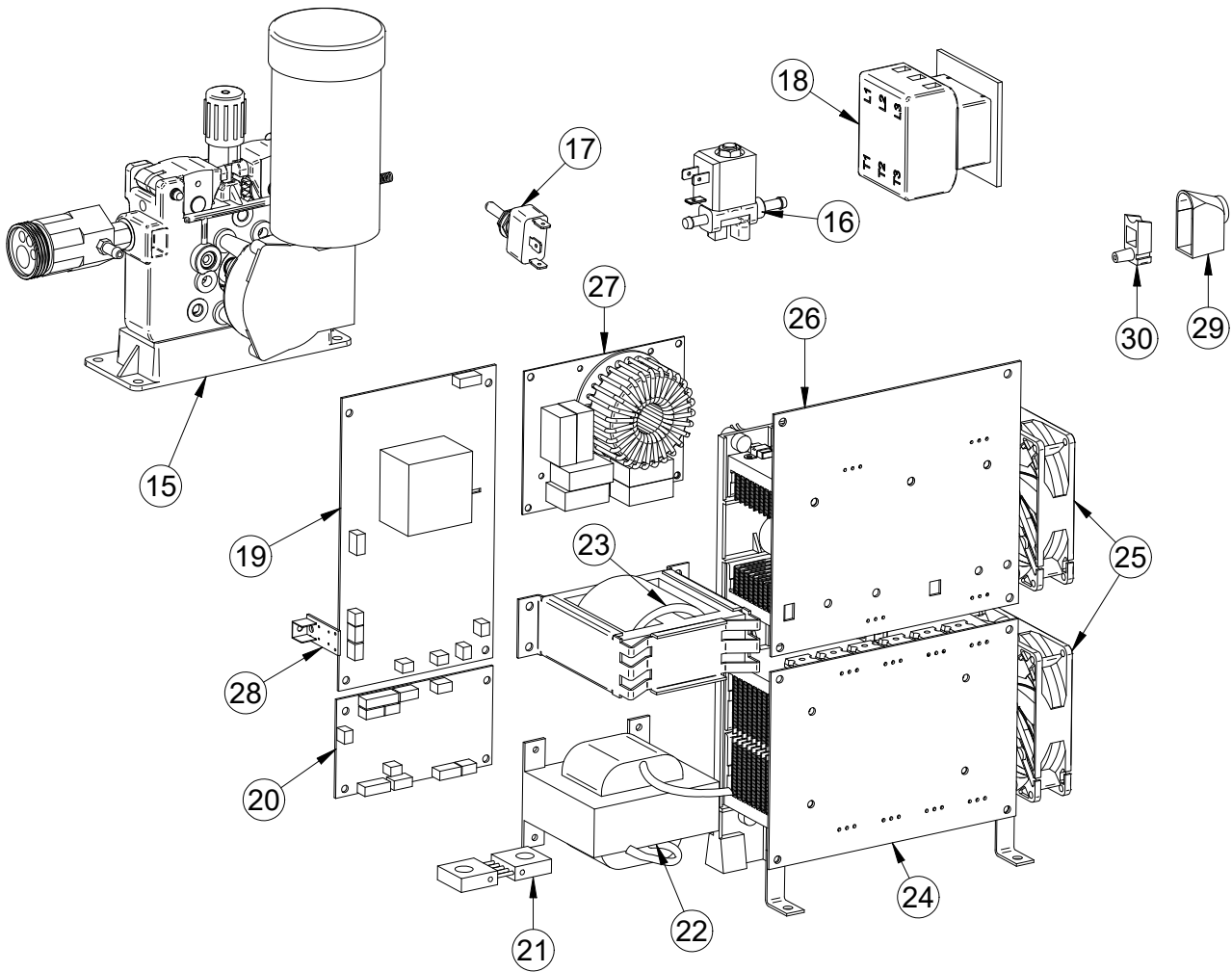

Figure B

Figure B: Inside Machine Assembly

Item	Description	Part Number	QTY	1	2	3	4	5	6	7
15	WIRE FEEDER ASSEMBLY	S33572-23	1	X	X					
16	GAS VALVE	S33572-24	1	X	X					
17	TOGGLE SWITCH HY29J	1115-280-004R	1	X	X					
18	SWITCH 400TPX, TH1538	W7511706R	1	X	X					
19	AUXILIARY POWER PCB	S33572-10	1	X	X					
20	CONTROL PCB	T-8040-172-1R	1	X						
	CONTROL PCB	T-8040-172-2R	1		X					
21	SHUNT	S33572-12	1	X	X					
22	CHOKE	S33572-13	1	X	X					
23	MAIN TRANSFORMER	S33572-14	1	X	X					
24	RECTIFICATION PCB	S33572-15	1	X	X					
25	FAN	S33572-16	2	X	X					
26	INVERTER PCB	S33572-17	1	X	X					
27	EMC FILTER	S33572-18	1	X	X					
28	SUPPRESSION PCB	S33572-19	1	X	X					
29	POWER CABLE GROMMET	1361-599-399R	1	X	X					
30	POWER CABLE CLAMP	1361-599-398R	1	X	X					

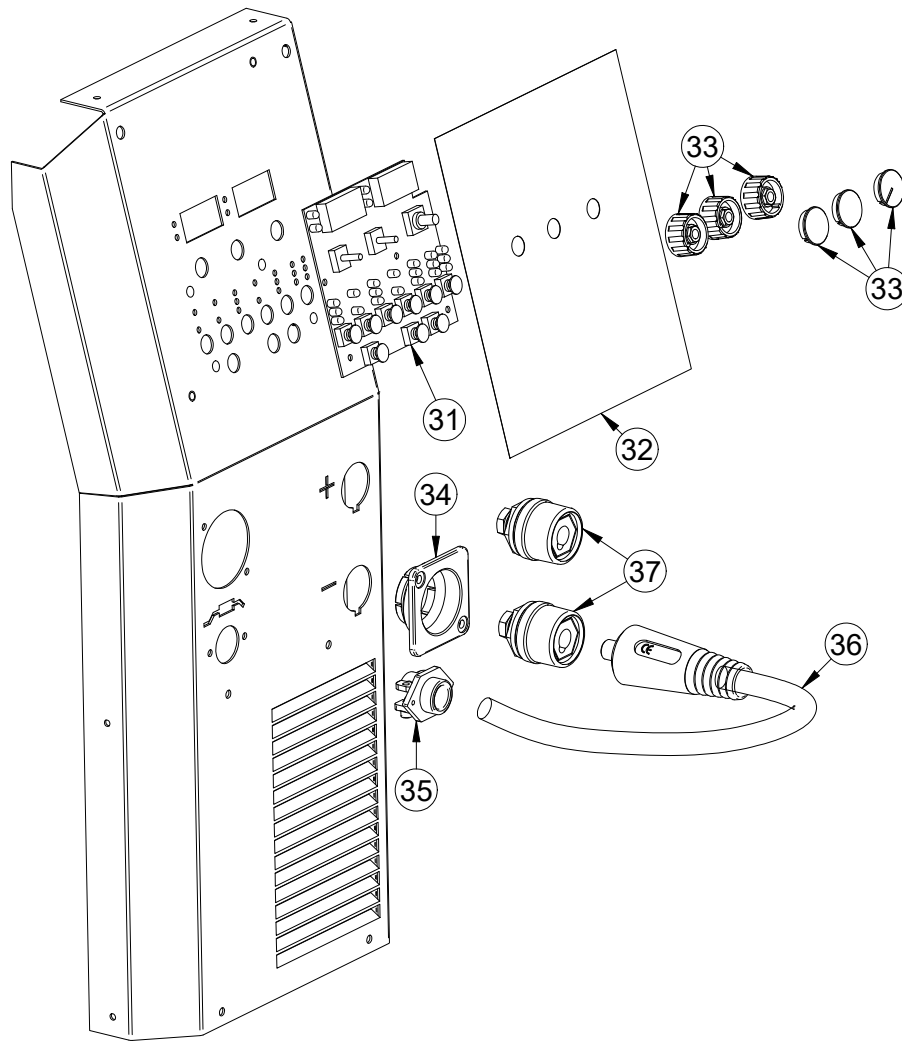

Figure C

Figure C: Front Assembly

Item	Description	Part Number	QTY	1	2	3	4	5	6	7
31	USER INTERFACE PCB	S33572-25	1	X	X					
32	FRONT PANEL LABEL	R-0000-372-1R	1	X						
	FRONT PANEL LABEL	R-0000-371-1R	1		X					
33	HOOD AND KNOB SET include:	T-8040-153-2R	1	X	X					
	KNOB D28		3	X	X					
	BLUE HOOD D = 29		2	X	X					
	CAP D28 BLUE + WHITE LINE		1	X	X					
34	COVER EURO	0646-231-005R	1	X	X					
35	STRAIN RELIEF	1361-599-674R	1	X	X					
36	POLARITY CHANGE HARNESS	T-5041-005-1R	1	X	X					
37	SOCKET X2, X3, X4	90000595PR	2	X	X					

Electrical Schematic

CODE: 50621, 50622

