



NOTE: This manual will cover most of the troubleshooting and repair procedures for the code numbers listed. Some variances may exist when troubleshooting/repairing later code numbers.

POWER WAVE® 355/405

For use with machines having Code Numbers:

10895 & 10896

SERVICE MANUAL

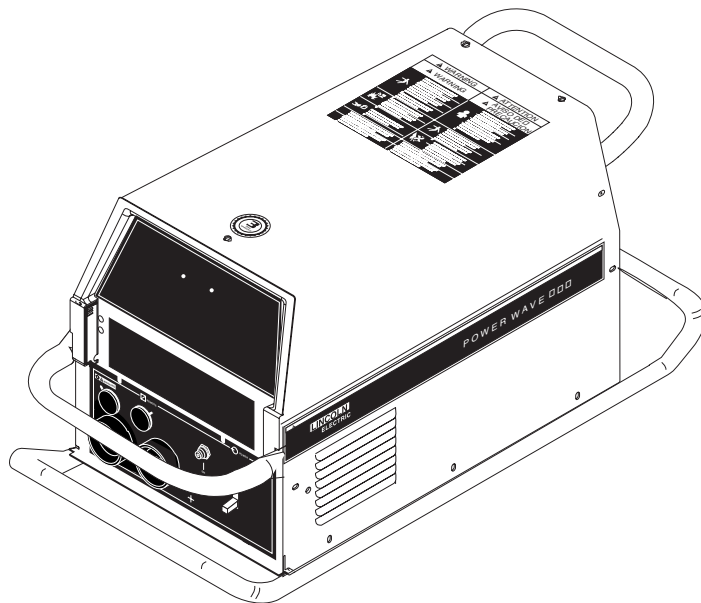

Need Help? Call 1.888.935.3877
to talk to a Service Representative

Hours of Operation:
8:00 AM to 6:00 PM (ET) Mon. thru Fri.

After hours?
Use "Ask the Experts" at lincolnelectric.com
A Lincoln Service Representative will contact you
no later than the following business day.

For Service outside the USA:
Email: globalservice@lincolnelectric.com

⚠ WARNING

⚠ CALIFORNIA PROPOSITION 65 WARNINGS ⚠

Diesel engine exhaust and some of its constituents are known to the State of California to cause cancer, birth defects, and other reproductive harm.

The Above For Diesel Engines

The engine exhaust from this product contains chemicals known to the State of California to cause cancer, birth defects, or other reproductive harm.

The Above For Gasoline Engines

ARC WELDING can be hazardous. PROTECT YOURSELF AND OTHERS FROM POSSIBLE SERIOUS INJURY OR DEATH. KEEP CHILDREN AWAY. PACEMAKER WEARERS SHOULD CONSULT WITH THEIR DOCTOR BEFORE OPERATING.

Read and understand the following safety highlights. For additional safety information, it is strongly recommended that you purchase a copy of "Safety in Welding & Cutting - ANSI Standard Z49.1" from the American Welding Society, P.O. Box 351040, Miami, Florida 33135 or CSA Standard W117.2-1974. A Free copy of "Arc Welding Safety" booklet E205 is available from the Lincoln Electric Company, 22801 St. Clair Avenue, Cleveland, Ohio 44117-1199.

BE SURE THAT ALL INSTALLATION, OPERATION, MAINTENANCE AND REPAIR PROCEDURES ARE PERFORMED ONLY BY QUALIFIED INDIVIDUALS.



FOR ENGINE powered equipment.

1.a. Turn the engine off before troubleshooting and maintenance work unless the maintenance work requires it to be running.



1.b. Operate engines in open, well-ventilated areas or vent the engine exhaust fumes outdoors.



1.c. Do not add the fuel near an open flame welding arc or when the engine is running. Stop the engine and allow it to cool before refueling to prevent spilled fuel from vaporizing on contact with hot engine parts and igniting. Do not spill fuel when filling tank. If fuel is spilled, wipe it up and do not start engine until fumes have been eliminated.

1.d. Keep all equipment safety guards, covers and devices in position and in good repair. Keep hands, hair, clothing and tools away from V-belts, gears, fans and all other moving parts when starting, operating or repairing equipment.

1.e. In some cases it may be necessary to remove safety guards to perform required maintenance. Remove guards only when necessary and replace them when the maintenance requiring their removal is complete. Always use the greatest care when working near moving parts.



1.f. Do not put your hands near the engine fan. Do not attempt to override the governor or idler by pushing on the throttle control rods while the engine is running.

1.g. To prevent accidentally starting gasoline engines while turning the engine or welding generator during maintenance work, disconnect the spark plug wires, distributor cap or magneto wire as appropriate.

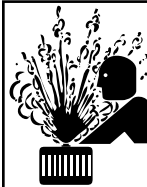

1.h. To avoid scalding, do not remove the radiator pressure cap when the engine is hot.



ELECTRIC AND MAGNETIC FIELDS may be dangerous

2.a. Electric current flowing through any conductor causes localized Electric and Magnetic Fields (EMF). Welding current creates EMF fields around welding cables and welding machines

2.b. EMF fields may interfere with some pacemakers, and welders having a pacemaker should consult their physician before welding.

2.c. Exposure to EMF fields in welding may have other health effects which are now not known.

2.d. All welders should use the following procedures in order to minimize exposure to EMF fields from the welding circuit:

2.d.1. Route the electrode and work cables together - Secure them with tape when possible.

2.d.2. Never coil the electrode lead around your body.

2.d.3. Do not place your body between the electrode and work cables. If the electrode cable is on your right side, the work cable should also be on your right side.

2.d.4. Connect the work cable to the workpiece as close as possible to the area being welded.

2.d.5. Do not work next to welding power source.



ELECTRIC SHOCK can kill.

3.a. The electrode and work (or ground) circuits are electrically “hot” when the welder is on. Do not touch these “hot” parts with your bare skin or wet clothing. Wear dry, hole-free gloves to insulate hands.

3.b. Insulate yourself from work and ground using dry insulation. Make certain the insulation is large enough to cover your full area of physical contact with work and ground.

In addition to the normal safety precautions, if welding must be performed under electrically hazardous conditions (in damp locations or while wearing wet clothing; on metal structures such as floors, gratings or scaffolds; when in cramped positions such as sitting, kneeling or lying, if there is a high risk of unavoidable or accidental contact with the workpiece or ground) use the following equipment:

- Semiautomatic DC Constant Voltage (Wire) Welder.
- DC Manual (Stick) Welder.
- AC Welder with Reduced Voltage Control.

3.c. In semiautomatic or automatic wire welding, the electrode, electrode reel, welding head, nozzle or semiautomatic welding gun are also electrically “hot”.

3.d. Always be sure the work cable makes a good electrical connection with the metal being welded. The connection should be as close as possible to the area being welded.

3.e. Ground the work or metal to be welded to a good electrical (earth) ground.

3.f. Maintain the electrode holder, work clamp, welding cable and welding machine in good, safe operating condition. Replace damaged insulation.

3.g. Never dip the electrode in water for cooling.

3.h. Never simultaneously touch electrically “hot” parts of electrode holders connected to two welders because voltage between the two can be the total of the open circuit voltage of both welders.

3.i. When working above floor level, use a safety belt to protect yourself from a fall should you get a shock.

3.j. Also see Items 6.c. and 8.



ARC RAYS can burn.

4.a. Use a shield with the proper filter and cover plates to protect your eyes from sparks and the rays of the arc when welding or observing open arc welding. Headshield and filter lens should conform to ANSI Z87.1 standards.

4.b. Use suitable clothing made from durable flame-resistant material to protect your skin and that of your helpers from the arc rays.

4.c. Protect other nearby personnel with suitable, non-flammable screening and/or warn them not to watch the arc nor expose themselves to the arc rays or to hot spatter or metal.



FUMES AND GASES can be dangerous.

5.a. Welding may produce fumes and gases hazardous to health. Avoid breathing these fumes and gases. When welding, keep your head out of the fume. Use enough ventilation and/or exhaust at the arc to keep fumes and gases away from the breathing zone. **When welding with electrodes which require special ventilation such as stainless or hard facing (see instructions on container or MSDS) or on lead or cadmium plated steel and other metals or coatings which produce highly toxic fumes, keep exposure as low as possible and within applicable OSHA PEL and ACGIH TLV limits using local exhaust or mechanical ventilation. In confined spaces or in some circumstances, outdoors, a respirator may be required. Additional precautions are also required when welding on galvanized steel.**

5.b. The operation of welding fume control equipment is affected by various factors including proper use and positioning of the equipment, maintenance of the equipment and the specific welding procedure and application involved. Worker exposure level should be checked upon installation and periodically thereafter to be certain it is within applicable OSHA PEL and ACGIH TLV limits.

5.c. Do not weld in locations near chlorinated hydrocarbon vapors coming from degreasing, cleaning or spraying operations. The heat and rays of the arc can react with solvent vapors to form phosgene, a highly toxic gas, and other irritating products.

5.d. Shielding gases used for arc welding can displace air and cause injury or death. Always use enough ventilation, especially in confined areas, to insure breathing air is safe.

5.e. Read and understand the manufacturer’s instructions for this equipment and the consumables to be used, including the material safety data sheet (MSDS) and follow your employer’s safety practices. MSDS forms are available from your welding distributor or from the manufacturer.

5.f. Also see item 1.b.

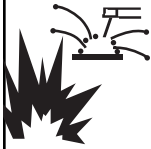

WELDING and CUTTING SPARKS can cause fire or explosion.

6.a. Remove fire hazards from the welding area. If this is not possible, cover them to prevent the welding sparks from starting a fire. Remember that welding sparks and hot materials from welding can easily go through small cracks and openings to adjacent areas. Avoid welding near hydraulic lines. Have a fire extinguisher readily available.

- 6.b. Where compressed gases are to be used at the job site, special precautions should be used to prevent hazardous situations. Refer to "Safety in Welding and Cutting" (ANSI Standard Z49.1) and the operating information for the equipment being used.
- 6.c. When not welding, make certain no part of the electrode circuit is touching the work or ground. Accidental contact can cause overheating and create a fire hazard.
- 6.d. Do not heat, cut or weld tanks, drums or containers until the proper steps have been taken to insure that such procedures will not cause flammable or toxic vapors from substances inside. They can cause an explosion even though they have been "cleaned". For information, purchase "Recommended Safe Practices for the Preparation for Welding and Cutting of Containers and Piping That Have Held Hazardous Substances", AWS F4.1 from the American Welding Society (see address above).
- 6.e. Vent hollow castings or containers before heating, cutting or welding. They may explode.
- 6.f. Sparks and spatter are thrown from the welding arc. Wear oil free protective garments such as leather gloves, heavy shirt, cuffless trousers, high shoes and a cap over your hair. Wear ear plugs when welding out of position or in confined places. Always wear safety glasses with side shields when in a welding area.
- 6.g. Connect the work cable to the work as close to the welding area as practical. Work cables connected to the building framework or other locations away from the welding area increase the possibility of the welding current passing through lifting chains, crane cables or other alternate circuits. This can create fire hazards or overheat lifting chains or cables until they fail.
- 6.h. Also see item 1.c.
- 6.i. Read and follow NFPA 51B "Standard for Fire Prevention During Welding, Cutting and Other Hot Work", available from NFPA, 1 Batterymarch Park, PO box 9101, Quincy, Ma 022690-9101.
- 6.j. Do not use a welding power source for pipe thawing.



CYLINDER may explode if damaged.

- 7.a. Use only compressed gas cylinders containing the correct shielding gas for the process used and properly operating regulators designed for the gas and pressure used. All hoses, fittings, etc. should be suitable for the application and maintained in good condition.
- 7.b. Always keep cylinders in an upright position securely chained to an undercarriage or fixed support.
- 7.c. Cylinders should be located:
 - Away from areas where they may be struck or subjected to physical damage.
 - A safe distance from arc welding or cutting operations and any other source of heat, sparks, or flame.
- 7.d. Never allow the electrode, electrode holder or any other electrically "hot" parts to touch a cylinder.
- 7.e. Keep your head and face away from the cylinder valve outlet when opening the cylinder valve.
- 7.f. Valve protection caps should always be in place and hand tight except when the cylinder is in use or connected for use.
- 7.g. Read and follow the instructions on compressed gas cylinders, associated equipment, and CGA publication P-1, "Precautions for Safe Handling of Compressed Gases in Cylinders," available from the Compressed Gas Association 1235 Jefferson Davis Highway, Arlington, VA 22202.



FOR ELECTRICALLY powered equipment.

- 8.a. Turn off input power using the disconnect switch at the fuse box before working on the equipment.
- 8.b. Install equipment in accordance with the U.S. National Electrical Code, all local codes and the manufacturer's recommendations.
- 8.c. Ground the equipment in accordance with the U.S. National Electrical Code and the manufacturer's recommendations.

Refer to <http://www.lincolnelectric.com/safety> for additional safety information.

PRÉCAUTIONS DE SÛRETÉ

Pour votre propre protection lire et observer toutes les instructions et les précautions de sûreté spécifiques qui paraissent dans ce manuel aussi bien que les précautions de sûreté générales suivantes:

Sûreté Pour Soudage A L'Arc

1. Protégez-vous contre la secousse électrique:
 - a. Les circuits à l'électrode et à la pièce sont sous tension quand la machine à souder est en marche. Eviter toujours tout contact entre les parties sous tension et la peau nue ou les vêtements mouillés. Porter des gants secs et sans trous pour isoler les mains.
 - b. Faire très attention de bien s'isoler de la masse quand on soude dans des endroits humides, ou sur un plancher métallique ou des grilles métalliques, principalement dans les positions assis ou couché pour lesquelles une grande partie du corps peut être en contact avec la masse.
 - c. Maintenir le porte-électrode, la pince de masse, le câble de soudage et la machine à souder en bon et sûr état de fonctionnement.
 - d. Ne jamais plonger le porte-électrode dans l'eau pour le refroidir.
 - e. Ne jamais toucher simultanément les parties sous tension des porte-électrodes connectés à deux machines à souder parce que la tension entre les deux pinces peut être le total de la tension à vide des deux machines.
 - f. Si on utilise la machine à souder comme une source de courant pour soudage semi-automatique, ces précautions pour le porte-électrode s'appliquent aussi au pistolet de soudage.
2. Dans le cas de travail au dessus du niveau du sol, se protéger contre les chutes dans le cas où on reçoit un choc. Ne jamais enrouler le câble-électrode autour de n'importe quelle partie du corps.
3. Un coup d'arc peut être plus sévère qu'un coup de soliel, donc:
 - a. Utiliser un bon masque avec un verre filtrant approprié ainsi qu'un verre blanc afin de se protéger les yeux du rayonnement de l'arc et des projections quand on soude ou quand on regarde l'arc.
 - b. Porter des vêtements convenables afin de protéger la peau de soudeur et des aides contre le rayonnement de l'arc.
 - c. Protéger l'autre personnel travaillant à proximité au soudage à l'aide d'écrans appropriés et non-inflammables.
4. Des gouttes de laitier en fusion sont émises de l'arc de soudage. Se protéger avec des vêtements de protection libres de l'huile, tels que les gants en cuir, chemise épaisse, pantalons sans revers, et chaussures montantes.
5. Toujours porter des lunettes de sécurité dans la zone de soudage. Utiliser des lunettes avec écrans latéraux dans les zones où l'on pique le laitier.

6. Eloigner les matériaux inflammables ou les recouvrir afin de prévenir tout risque d'incendie dû aux étincelles.
7. Quand on ne soude pas, poser la pince à un endroit isolé de la masse. Un court-circuit accidentel peut provoquer un échauffement et un risque d'incendie.
8. S'assurer que la masse est connectée le plus près possible de la zone de travail qu'il est pratique de le faire. Si on place la masse sur la charpente de la construction ou d'autres endroits éloignés de la zone de travail, on augmente le risque de voir passer le courant de soudage par les chaînes de levage, câbles de grue, ou autres circuits. Cela peut provoquer des risques d'incendie ou d'échauffement des chaînes et des câbles jusqu'à ce qu'ils se rompent.
9. Assurer une ventilation suffisante dans la zone de soudage. Ceci est particulièrement important pour le soudage de tôles galvanisées plombées, ou cadmiées ou tout autre métal qui produit des fumées toxiques.
10. Ne pas souder en présence de vapeurs de chlore provenant d'opérations de dégraissage, nettoyage ou pistologie. La chaleur ou les rayons de l'arc peuvent réagir avec les vapeurs du solvant pour produire du phosgène (gas fortement toxique) ou autres produits irritants.
11. Pour obtenir de plus amples renseignements sur la sûreté, voir le code "Code for safety in welding and cutting" CSA Standard W 117.2-1974.

PRÉCAUTIONS DE SÛRETÉ POUR LES MACHINES À SOUDER À TRANSFORMATEUR ET À REDRESSEUR

1. Relier à la terre le châssis du poste conformément au code de l'électricité et aux recommandations du fabricant. Le dispositif de montage ou la pièce à souder doit être branché à une bonne mise à la terre.
2. Autant que possible, l'installation et l'entretien du poste seront effectués par un électricien qualifié.
3. Avant de faire des travaux à l'intérieur de poste, la débrancher à l'interrupteur à la boîte de fusibles.
4. Garder tous les couvercles et dispositifs de sûreté à leur place.

Electromagnetic Compatibility (EMC)

Conformance

Products displaying the CE mark are in conformity with European Community Council Directive of 15 Dec 2004 on the approximation of the laws of the Member States relating to electromagnetic compatibility, 2004/108/EC. It was manufactured in conformity with a national standard that implements a harmonized standard: EN 60974-10 Electromagnetic Compatibility (EMC) Product Standard for Arc Welding Equipment. It is for use with other Lincoln Electric equipment. It is designed for industrial and professional use.

Introduction

All electrical equipment generates small amounts of electromagnetic emission. Electrical emission may be transmitted through power lines or radiated through space, similar to a radio transmitter. When emissions are received by other equipment, electrical interference may result. Electrical emissions may affect many kinds of electrical equipment; other nearby welding equipment, radio and TV reception, numerical controlled machines, telephone systems, computers, etc. Be aware that interference may result and extra precautions may be required when a welding power source is used in a domestic establishment.

Installation and Use

The user is responsible for installing and using the welding equipment according to the manufacturer's instructions. If electromagnetic disturbances are detected then it shall be the responsibility of the user of the welding equipment to resolve the situation with the technical assistance of the manufacturer. In some cases this remedial action may be as simple as earthing (grounding) the welding circuit, see Note. In other cases it could involve construction of an electromagnetic screen enclosing the power source and the work complete with associated input filters. In all cases electromagnetic disturbances must be reduced to the point where they are no longer troublesome.

Note: The welding circuit may or may not be earthed for safety reasons according to national codes. Changing the earthing arrangements should only be authorized by a person who is competent to access whether the changes will increase the risk of injury, e.g., by allowing parallel welding current return paths which may damage the earth circuits of other equipment.

Assessment of Area

Before installing welding equipment the user shall make an assessment of potential electromagnetic problems in the surrounding area. The following shall be taken into account:

- a) other supply cables, control cables, signaling and telephone cables; above, below and adjacent to the welding equipment;
- b) radio and television transmitters and receivers;
- c) computer and other control equipment;
- d) safety critical equipment, e.g., guarding of industrial equipment;
- e) the health of the people around, e.g., the use of pacemakers and hearing aids;
- f) equipment used for calibration or measurement
- g) the immunity of other equipment in the environment. The user shall ensure that other equipment being used in the environment is compatible. This may require additional protection measures;
- h) the time of day that welding or other activities are to be carried out.

Electromagnetic Compatibility (EMC)

The size of the surrounding area to be considered will depend on the structure of the building and other activities that are taking place. The surrounding area may extend beyond the boundaries of the premises.

Methods of Reducing Emissions

Mains Supply

Welding equipment should be connected to the mains supply according to the manufacturer's recommendations. If interference occurs, it may be necessary to take additional precautions such as filtering of the mains supply. Consideration should be given to shielding the supply cable of permanently installed welding equipment, in metallic conduit or equivalent. Shielding should be electrically continuous throughout its length. The shielding should be connected to the welding power source so that good electrical contact is maintained between the conduit and the welding power source enclosure.

Maintenance of the Welding Equipment

The welding equipment should be routinely maintained according to the manufacturer's recommendations. All access and service doors and covers should be closed and properly fastened when the welding equipment is in operation. The welding equipment should not be modified in any way except for those changes and adjustments covered in the manufacturer's instructions. In particular, the spark gaps of arc striking and stabilizing devices should be adjusted and maintained according to the manufacturer's recommendations.

Welding Cables

The welding cables should be kept as short as possible and should be positioned close together, running at or close to floor level.

Equipotential Bonding

Bonding of all metallic components in the welding installation and adjacent to it should be considered. However, metallic components bonded to the work piece will increase the risk that the operator could receive a shock by touching these metallic components and the electrode at the same time. The operator should be insulated from all such bonded metallic components.

Earthing of the Workpiece

Where the workpiece is not bonded to earth for electrical safety, not connected to earth because of its size and position, e.g., ships hull or building steelwork, a connection bonding the workpiece to earth may reduce emissions in some, but not all instances. Care should be taken to prevent the earthing of the workpiece increasing the risk of injury to users, or damage to other electrical equipment. Where necessary, the connection of the workpiece to earth should be made by a direct connection to the workpiece, but in some countries where direct connection is not permitted, the bonding should be achieved by suitable capacitance, selected according to national regulations.

Screening and Shielding

Selective screening and shielding of other cables and equipment in the surrounding area may alleviate problems of interference. Screening of the entire welding installation may be considered for special applications.¹

¹ Portions of the preceding text are contained in EN 60974-10: "Electromagnetic Compatibility (EMC) product standard for arc welding equipment."

MASTER TABLE OF CONTENTS FOR ALL SECTIONS

	Page
Safety	i-vi
Installation	Section A
Operation	Section B
Accessories	Section C
Maintenance	Section D
Theory of Operation	Section E
Troubleshooting and Repair	Section F
How to Use Troubleshooting Guide	F-2
Troubleshooting Guide	F-4
Test Procedures	F-15
Replacement Procedures	F-49
Electrical Diagrams	Section G
Parts Manual	P-401 Series

TABLE OF CONTENTS - INSTALLATION SECTION -

Installation

Technical Specifications 355.....	A-2
Technical Specifications 405.....	A-3
Safety Precautions.....	A-4
Stacking	A-4
Tilting.....	A-4
Input Grounding Connections	A-4
Power Cord Connection.....	A-4
Output Cables, Connections and Limitations	A-5
Negative Electrode Polarity	A-5
Voltage Sensing.....	A-5
Power Wave to Semi-Automatic Wire Feeder	A-6
System Description	A-7
System Set-up	A-8
Multiple Group System	A-9
Single Group Multi-Head System	A-10
Welding with Multiple Power Waves	A-11
Control Cable Specifications.....	A-11
I/O Receptacle Specifications.....	A-12
Dip Switch Settings and Locations	A-12

Return to Master TOC

Return to Master TOC

Return to Master TOC

Return to Master TOC

TECHNICAL SPECIFICATIONS - POWER WAVE® 355

INPUT AC VOLTAGE & DC OUTPUT

Product Name	Ordering Information	Input AC Voltage	Rated DC Output Amps/Volts/Duty Cycle	Output Range (continuous)	Weight with Cord	Dimensions HxWxD
Power Wave 355	K2152-1	200-208 220-240 380-415 440-480 575 60/50 HZ	350A / 34V / 60% 1 & 3 Phase 300A / 32V / 100% 1 & 3 Phase	AMPS 5-425	(81.5 lbs.) (37.0 kg.)	14.8" x 13.3" x 27.8"* (373 x 338 x 706*)mm *Includes Handles

* Overall Length Including Handle, 21.6" (549mm) without handle.

POWER WAVE® 355 INPUT CURRENT

Recommended Fuse Sizes Base On The U.S. National Electrical Code And Maximum Machine Outputs

Input 50/60 Hz		Output		Recommended		Notes
Voltage	Phases	300Amps @ 32Volts(100%)	350Amps @ 34Volts(60%)	Line Cord AWG	Fuse size	
200	1	Not Recommended	Not Recommended		---	Note 1
208	1	76	94	2	125A	Note 2
230	1	69	85	4	125A	Note 2
380	1	Not Recommended	Not Recommended		---	Note 1
400	1	Not Recommended	Not Recommended	---	---	Note 1
415	1	41	64	6	80A	Note 2
460	1	36	42	8	70A	
575	1	31	37	8	50A	
200	3	41	50	6	80A	Note 2
208	3	39	50	6	80A	Note 2
230	3	36	42	8	70A	
380	3	23	28	8	50A	
400	3	22	27	8	50A	
415	3	22	26	8	50A	
460	3	19	23	8	50A	
575	3	16	18	8	35A	

Note 1. Not rated is indicated by 4-x's in the box on the rating plate.

Note 2. When operating on these inputs, the line cord should be changed to an input conductor of 6 AWG or larger.

OUTPUT CABLES, CONNECTIONS AND LIMITATIONS

Select The output cable size based upon the following chart.*

Cable sizes for Combined Length of Electrode and Work Cable (Copper) 75C rated:

DUTY CYCLE	CURRENT	LENGTH UP 200FT.(61m)	200-250 FT. (61-76m)
100%	300	1/0	1/0
60%	350	1/0	2/0

*Lincoln Electric recommends using a minimum of 2/0 welding cable for pulse welding.

POWER WAVE® 355/405



Return to Section TOC | Return to Master TOC

INSTALLATION

TECHNICAL SPECIFICATIONS - POWER WAVE® 405

INPUT AC VOLTAGE & DC OUTPUT

Product Name	Ordering Information	Input AC Voltage	Rated DC Output Amps/Volts/Duty Cycle	Output Range (continuous)	Weight with Cord	Dimensions HxWxD
Power Wave 405	K 2152-2	200-208 / 220-240/ 380-415/ 3/50/60	350A / 34V / 60% 3 Phase 320A / 33V / 60% 1 Phase	AMPS 5-425	86.5lbs (37.4 kg)	14.7"x12.5"x 27.8"* (373x318x 706*)mm * Includes handles
		60/50 Hz	275A / 31V / 100% 1 Phase 300A / 32V / 100% 3 Phase			

* Overall Length Including Handle, 21.6" (549mm) without handle.

POWER WAVE® 405 INPUT CURRENT

Recommended Fuse Sizes Based On The U.S. National Electrical Code And Maximum Machine Outputs

Input 50/60 Hz		Output		Recommended		Notes
Voltage	Phases	300Amps@ 32Volts(100%)	350Amps@ 34Volts(60%)	Line Cord Size mm ²	Size Fuse Size	
200	3	41	48	16	80A	Note 2
220	3	37	48	16	80A	Note 2
380	3	23	28	10	50A	
400	3	22	27	10	50A	
415	3	22	26	10	50A	

Voltage	Phases 31Volts(100%)	275Amps@ 33Volts(60%)	320Amps@	Line Cord Size mm ²	Fuse Size	Notes
200	1	Not Recommended	Not Recommended	---	----	Note 1
220	1	64	82	20	125A	Note 2
380	1	44	55	16	80A	Note 2
400	1	40	50	10	80A	
415	1	38	48	10	80A	

1. Not rated is indicated by 4-x's in the box on the rating plate
2. When operating on these inputs, the line cord should be changed to an input conductor of 6 AWG or larger.

OUTPUT CABLES, CONNECTIONS AND LIMITATIONS

Select the output cable size based upon the following chart.

Cable sizes for Combined Length of Electrode and Work Cable (Copper) 75C rated:

DUTY CYCLE	CURRENT	LENGTH UP 61m (200 FT)	61-76m (200-250 FT)
100%	275	1/0	1/0
60%	350	1/0	2/0

POWER WAVE® 355/405



INSTALLATION

SAFETY PRECAUTIONS

⚠ WARNING



ELECTRIC SHOCK can kill.

- **TURN THE INPUT POWER OFF AT THE DISCONNECT SWITCH BEFORE ATTEMPTING TO CONNECT OR DISCONNECT INPUT POWER LINES, OUTPUT CABLES, OR CONTROL CABLES.**
- Only qualified personnel should perform this installation.
- Connect the green/yellow lead of the power cord to ground per U.S.National Electrical Code.

SELECT SUITABLE LOCATION

In order to assure long life and reliable operation, the owner of this machine should follow these simple preventative measures:

- The machine must be located where there is free circulation of clean air such that air movement in the back, out the sides and bottom will not be restricted.
- Dirt and dust that can be drawn into the machine should be kept to a minimum. Failure to observe these precautions can result in excessive operating temperatures and nuisance shutdown.
- Keep machine dry. Shelter from rain and snow. Do not place on wet ground or in puddles.
- **DO NOT MOUNT OVER COMBUSTIBLE SURFACES.** Where there is a combustible surface directly under

⚠ CAUTION

stationary or fixed electrical equipment, that surface shall be covered with a steel plate at least .06”(1.6mm) thick, which shall extend not less than 5.90”(150mm) beyond the equipment on all sides.

STACKING

POWER WAVE® 355/405 cannot be stacked.

TILTING

Place the machine directly on a secure, level surface or on a recommended undercarriage. The machine may topple over if this procedure is not followed.

INPUT AND GROUNDING CONNECTIONS

- Only a qualified electrician should connect the POWER WAVE® 355/405. Installation should be made in accordance with the appropriate National Electrical Code, all local codes and the information detailed below.
- When received directly from the factory, multiple voltage machines are internally connected for the highest voltage. Always double-check connections before powering up the machine.
- Initial 200VAC - 415VAC and 575VAC operation will require an Input voltage panel setup.

- Open the access panel on the rear of the machine.
- For 200 or 230: Position the large switch to 200-230.
For higher voltages: Position the large switch to 380-575.
- Move the "A" lead to the appropriate terminal.

POWER CORD CONNECTION

A power cord is provided and wired into the machine. Follow the power cord connection instructions.

Machine	Cord Length
PW 355	10 Feet
PW 405	5 Meters

⚠ CAUTION

Incorrect connection may result in equipment damage.

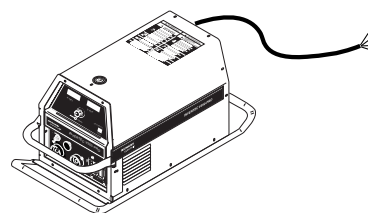

Single Phase Input (PW 355)

Connect green lead to ground per National Electrical Code.

Connect black and white leads to power.

Wrap red lead with tape to provide 600V insulation.

Three Phase Input (PW 355)

Connect green lead to ground per National Electric Code.

Connect black, red and white leads to power.

Lead Color	Single Phase	Three Phase
Green	Connect to ground per NEC	Connect to ground per NEC
Black	Power Lead	Power Lead
White	Power Lead	Power Lead
Red	Tape, provide 600V insulation	Power Lead

Single Phase Input (PW 405)

Connect green/yellow lead to ground per National Electrical Code.

Connect blue and brown leads to power.

Wrap black lead with tape to provide 600V insulation.

Three Phase Input (PW 405)

Connect green/yellow lead to ground per National Electric Code.

Connect black, blue and brown leads to power.

POWER WAVE® 355/405



Return to Section TOC
Return to Master TOC

INSTALLATION

UNDERCARRIAGE MOUNTINGS

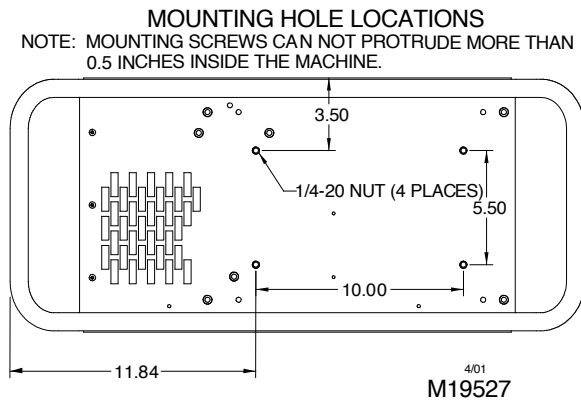

OUTPUT CABLES, CONNECTIONS AND LIMITATIONS

Connect a work lead of sufficient size and length between the proper output terminal on the power source and the work. Be sure the connection to the work makes tight metal-to-metal electrical contact. To avoid interference problems with other equipment and to achieve the best possible operation, route all cables directly to the work or wire feeder. Avoid excessive lengths and do not coil excess cable.

CAUTION

When using an inverter type power source like the PowerWaves, use the largest welding (electrode and work) cables that are practical. At least 2/0 copper wire - even if the average output current would not normally require it. When pulsing, the pulse current can reach very high levels. Voltage drops can become excessive, leading to poor welding characteristics, if undersized welding cables are used.

Most welding applications run with the electrode being positive (+). For those applications, connect the electrode cable between the wire feeder and the positive (+) output Twist-Mate terminal on the power source. Connect the other end of the electrode cable to the wire drive feed plate. The electrode cable lug must be against the feed plate. Be sure the connection to the feed plate makes tight metal-to-metal electrical contact. The electrode cable should be sized according to the specifications given in the output cable connections section. Connect a work lead from the negative (-) power source output Twist-Mate terminal to the work piece. The work piece connection must be firm and secure, especially if pulse welding is planned.

For additional Safety information regarding the electrode and work cable set-up, See the standard "SAFETY INFORMATION" located in the front of the Instruction Manuals.



CAUTION

Excessive voltage drops caused by poor work piece connections often result in unsatisfactory welding performance.

NEGATIVE ELECTRODE POLARITY

When negative electrode polarity is required, such as in some Innershield applications, reverse the output connections at the power source (electrode cable to the negative (-) Twist-Mate terminal, and work cable to the positive (+) Twist-Mate terminal).

When operating with electrode polarity negative the "Electrode Sense Polarity" DIP switch must be set to the "Negative" position on the Wire Drive Feed Head PC Board. The default setting of the switch is positive electrode polarity. Consult the Power Feed instruction manual for further details.

VOLTAGE SENSING

The best arc performance occurs when the PowerWaves have accurate data about the arc conditions. Depending upon the process, inductance within the electrode and work lead cables can influence the voltage apparent at the studs of the welder. Voltage sense leads improve the accuracy of the arc conditions and can have a dramatic effect on performance. Sense Lead Kits (K940-10, -25 or -50) are available for this purpose.



CAUTION

If the voltage sensing is enabled but the sense leads are missing, improperly connected, or if the electrode polarity switch is improperly configured, extremely high welding outputs may occur.

The ELECTRODE sense lead (67) is built into the control cable, and is automatically enabled for all semi-automatic processes. The WORK sense lead (21) connects to the Power Wave at the four pin connector. By default the WORK voltage is monitored at the output stud in the POWER WAVE® 355/405. For more information on the WORK sense lead (21), see **Work Voltage Sensing** on the following page.

POWER WAVE® 355/405



INSTALLATION

Enable the voltage sense leads as follows:

TABLE A.1

Process	Electrode Voltage Sensing 67 lead *	Work Voltage Sensing 21 lead
GMAW	67 lead required	21 lead optional
GMAW-P	67 lead required	21 lead optional
FCAW	67 lead required	21 lead optional
GTAW	Voltage sense at studs	Voltage sense at studs
GMAW	Voltage sense at studs	Voltage sense at studs
SAW	67 lead required	21 lead optional
CAC-C	Voltage sense at studs	Voltage sense at studs

* The electrode voltage 67 sense lead is integral to the control cable to the wire feeder.

Work Voltage Sensing

The standard POWER WAVE® 355/405 default to the work stud (work sense lead disabled)

For processes requiring work voltage sensing, connect the (21) work voltage sense lead (K940) from the Power Wave work sense lead receptacle to the work piece. Attach the sense lead to the work piece as close to the weld as practical, but not in the return current path. Enable the work voltage sensing in the Power Wave as follows:

WARNING



- Do not touch electrically live parts or electrodes with your skin or wet clothing.
- Insulate yourself from the work and ground.

- Always wear dry insulating gloves.

1. Turn off power to the power source at the disconnect switch.
2. Remove the wrap around cover from the power source.
3. The control board is on the center assembly facing the case front. Locate the 8-position DIP switch and look for switch 8 of the DIP switch.
4. Using a pencil or other small object, slide the switch to the OFF position if the work sense lead is NOT connected. Conversely, slide the switch to the ON position if the work sense lead is present.

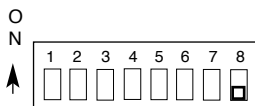

5. Replace the wrap around and screws. The PC board will “read” the switch at power up, and configure the work voltage sense lead appropriately.

ELECTRODE VOLTAGE SENSING

Enabling or disabling electrode voltage sensing is automatically configured through software. The 67 electrode sense lead is internal to the cable to the wire feeder and always connected when a wire feeder is present.



CAUTION

Important: The electrode polarity must be configured at the feed head for all semi-automatic processes. Failure to do so may result in extremely high welding outputs.

POWER WAVE® TO SEMI-AUTOMATIC POWERFEED WIRE FEEDER INTERCONNECTIONS

The POWER WAVE® 355/405 and semi-automatic PowerFeed family communicate via a 5 conductor control cable (K1543). The control cable consists of two power leads, one twisted pair for digital communication, and one lead for voltage sensing. The cables are designed to be connected end to end for ease of extension. The output receptacle on the POWER WAVE 405 is on the case front. The input receptacle on the Power Feed is typically located at the back of the feeder, or on the bottom of the user interface.

Due to the flexibility of the platform the configuration may vary. The following is a general description of the system. For specific configuration information, consult the semi-automatic Power Feed instruction manual.

POWER WAVE® 355/405



INSTALLATION

SYSTEM DESCRIPTION

The POWER WAVE® 355/405 and Power Feed 10/11 family of products utilize a digital communication system called Linc-Net. Simply put, Linc-Net allows large amounts of information to be passed at very high speeds between components (nodes) in the system. The system requires only two wires for communication, and because of its bus-like structure, the components may be connected to the network in any order, thus simplifying the system set-up.

Each "system" must contain only one power source. The power source may be connected to a maximum of four feeder groups. Each group containing one user interface (UI), and up to seven Feed Heads (FH). SEE FIGURE A.1. The UI controls all of the FH's of that group. The UI's and FH's are assigned to groups by setting a code on the DIP switches mounted on their individual control boards. For example all of the FH's to be controlled by a given UI must have their "Group ID" switches set to the same group number as the UI. In addition, each FH must be assigned a separate FH number within that group. See the system set-up section for further details.

From a network perspective, each component in the system is considered a separate node, regardless of its physical location. For example, even though a UI and FH may be physically mounted together, they are still viewed as separate pieces (nodes) by the network, and can only communicate via Linc-Net. The Linc-Net connection is generally made external through the Linc-Net Control Cable, but can also be made internally, as with the PF-10 bench model feeder.

The most common Linc-Net configuration (called a simple system) consists of one power source, one user interface and one feeder. Under these circumstances the group and feed head ID DIP switches are ignored and the system will function regardless of their position. The same is true for the minimum system consisting of a power source and one UI (Example: a stick welding system).

System Model

FIGURE A.1

Maximum Configuration

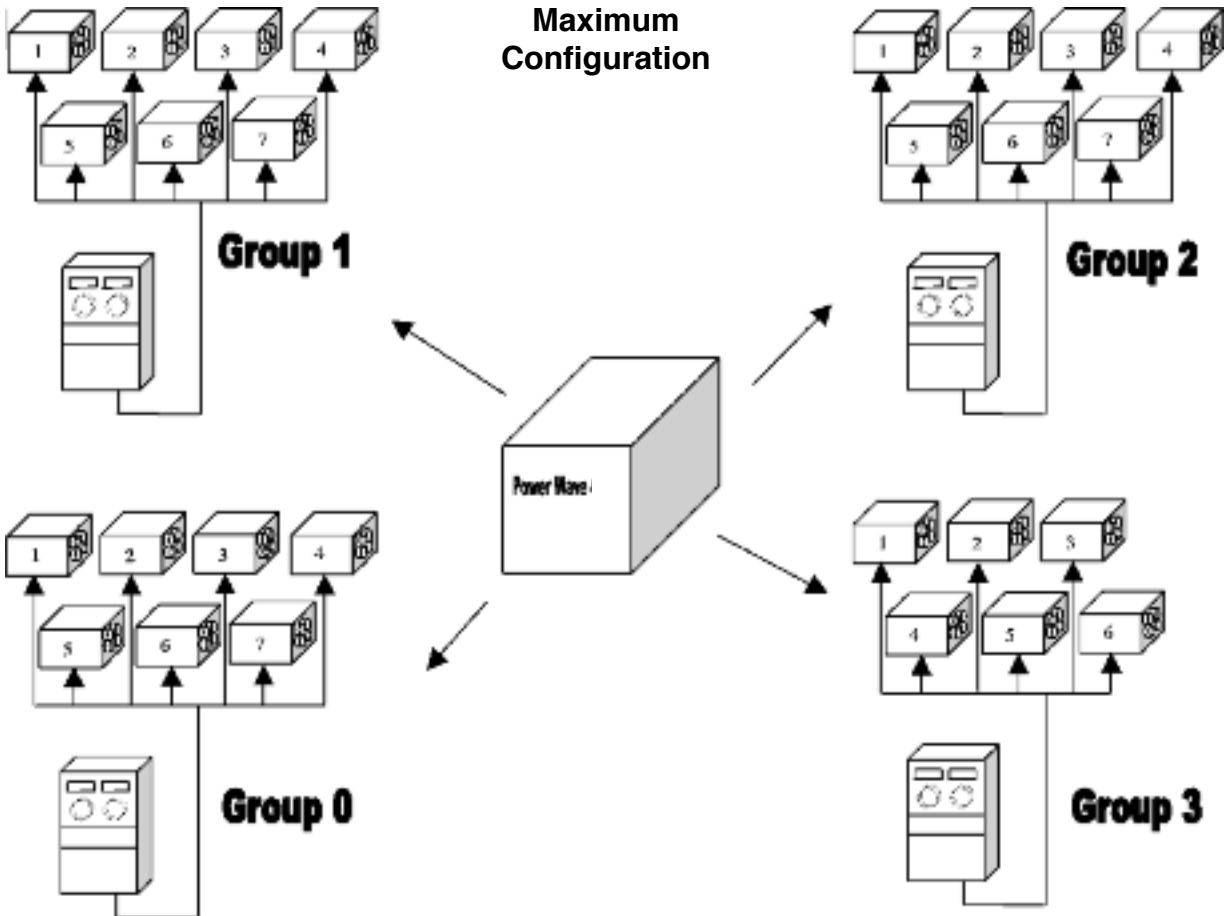

POWER WAVE® 355/405



[Return to Section TOC](#) | [Return to Master TOC](#)

INSTALLATION

SYSTEM SET-UP

Basic Rules

- Each group is required to have one user interface. No group may have more than one user interface.
- Each group can have up to seven Feed Heads.
Exception: Group 3 is limited to a maximum of six Feed Heads.
- Each system has only one power source. For network purposes, the PS belongs to Group 3, which is why group 3 is only allowed 6 feed heads in addition it's user interface.
- No two feed heads can have identical Group and Feed Head numbers.
- Group and Feed Head ID numbers must be set on the appropriate dip switches at each node. Consult the PF-10/11 Instruction Manual for specific details regarding dip switch settings.
- Feed head "0" not allowed. **Exception:** Simple system ignores all ID numbers, therefore "FH0" will function.
- Each node must be connected to the Linc-Net communication network. The order of connection is not important, as each node is identified by it's unique Group and Feed Head ID number as defined on it's dip switches. See Figures A.2 thru A.5.

Simple System

FIGURE A.2

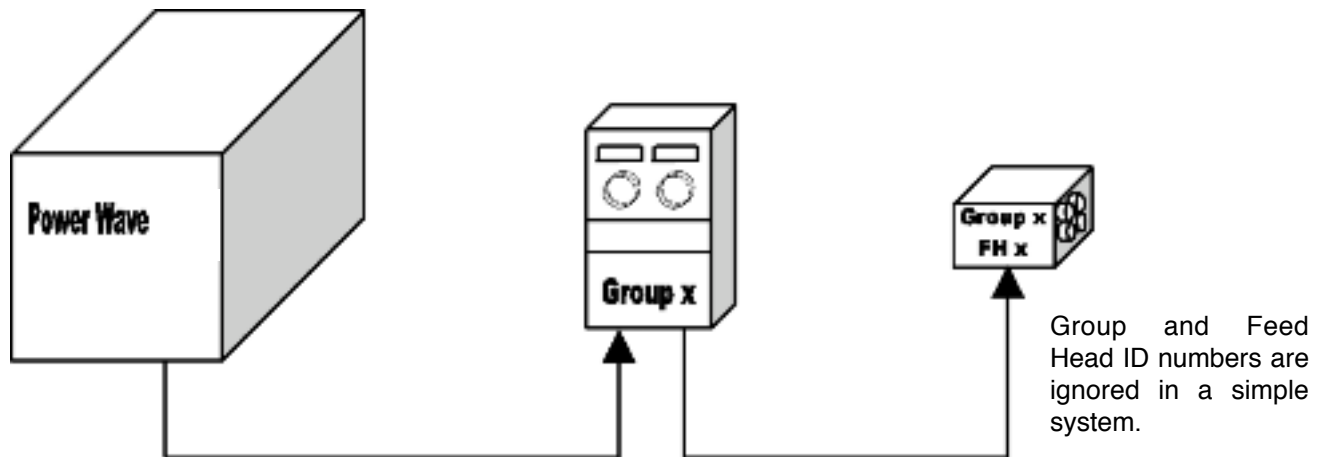

POWER WAVE® 355/405

LINCOLN
ELECTRIC

INSTALLATION

Multiple Group System

FIGURE A.3

No "FH0 Allowed!

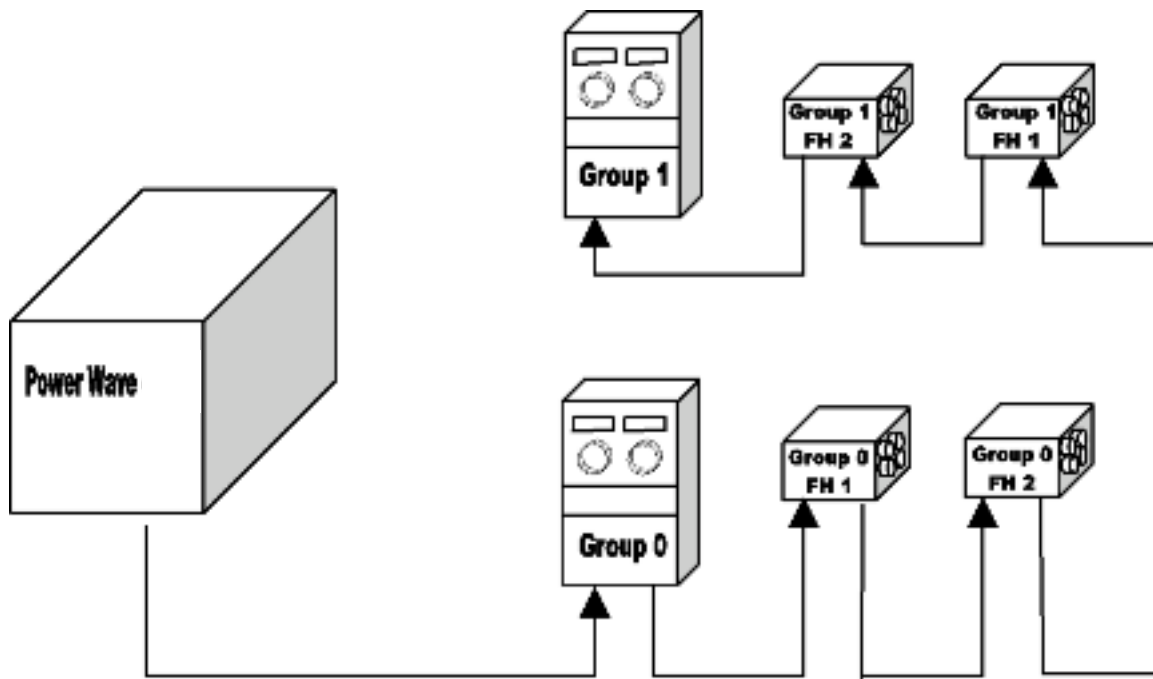

Single Group Multi-Head System

FIGURE A.4

No "FH0 Allowed!

The Dual Head option allows the ability to maintain 2 sets of procedures. If more than 2 heads are used, odd #'s use FH1 settings, even #'s use FH2 settings.

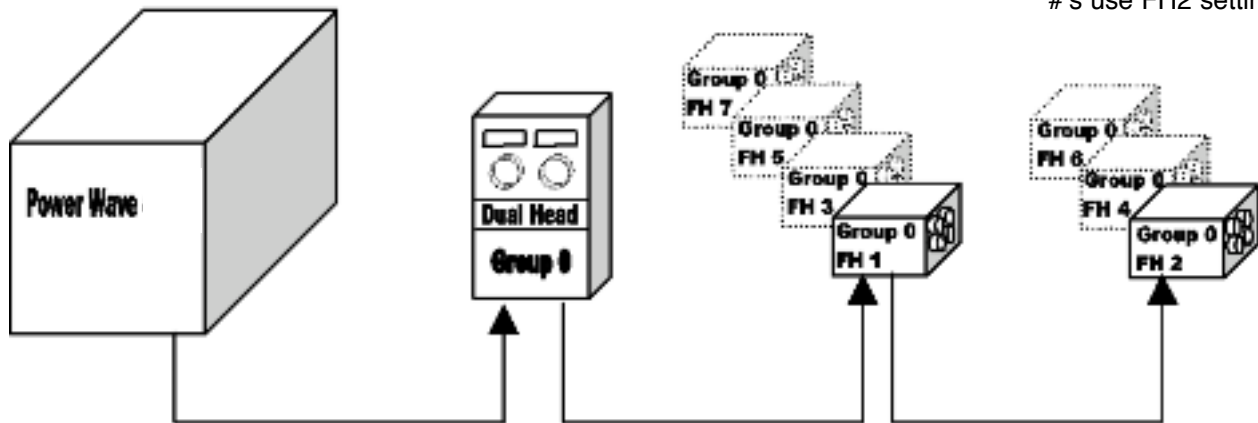

Return to Section TOC
 Return to Section TOC
 Return to Section TOC
 Return to Master TOC
 Return to Master TOC
 Return to Master TOC

INSTALLATION

Single Group Multi-Head System (Alternate Method)

FIGURE A.5

No "FH0 Allowed!

When a standard User Interface is used in a group with multiple Feed Heads, all of the Feed Heads use a single set of procedures.

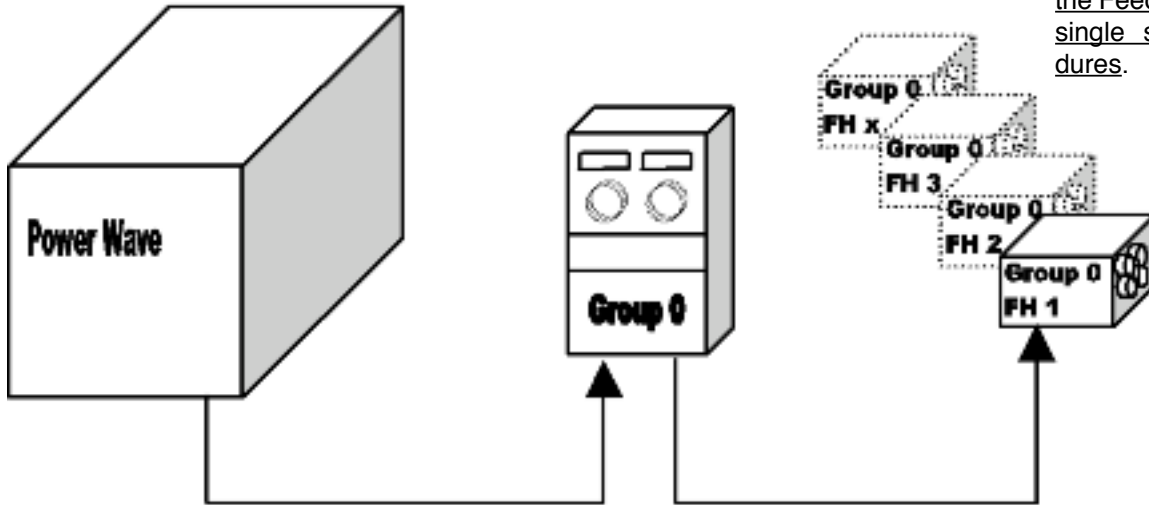

Return to Section TOC
Return to Master TOC
Return to Section TOC
Return to Master TOC
Return to Section TOC
Return to Master TOC
Return to Section TOC
Return to Master TOC

INSTALLATION

WELDING WITH MULTIPLE POWER WAVES



CAUTION

Special care must be taken when more than one Power Wave is welding simultaneously on a single part. Arc blow and arc interference may occur or be magnified.

Each power source requires a work lead from the work stud to the welding fixture. Do not combine all of the work leads into one lead. The welding travel directions should be in the direction moving away from the work lead as shown below. Connect all of the work sense leads from each power source to the work piece at the end of the weld.

For the best results when pulse welding, set the wire size and wire feed speed the same for all the Power Waves. When these parameters are identical, the pulsing frequency will be the same, helping to stabilize the arcs.

Every welding gun requires a separate shielding gas regulator for proper flow rate and shielding gas coverage.

Do not attempt to supply shielding gas for two or more guns from only one regulator.

If an anti-spatter system is in use then each gun must have its own anti-spatter system. (See Figure A.6)

CONTROL CABLE SPECIFICATIONS

It is recommended that genuine Lincoln control cables be used at all times. Lincoln cables are specifically designed for the communication and power needs of the Power Wave / Power Feed system.



CAUTION

The use of non-standard cables, especially in lengths greater than 25 feet, can lead to communication problems (system shutdowns), poor motor acceleration (poor arc starting) and low wire driving force (wire feeding problems).

The K1543 series of control cables can be connected end to end for ease of extension. Do not exceed more than 100 feet (30.5 m) total control cable length.

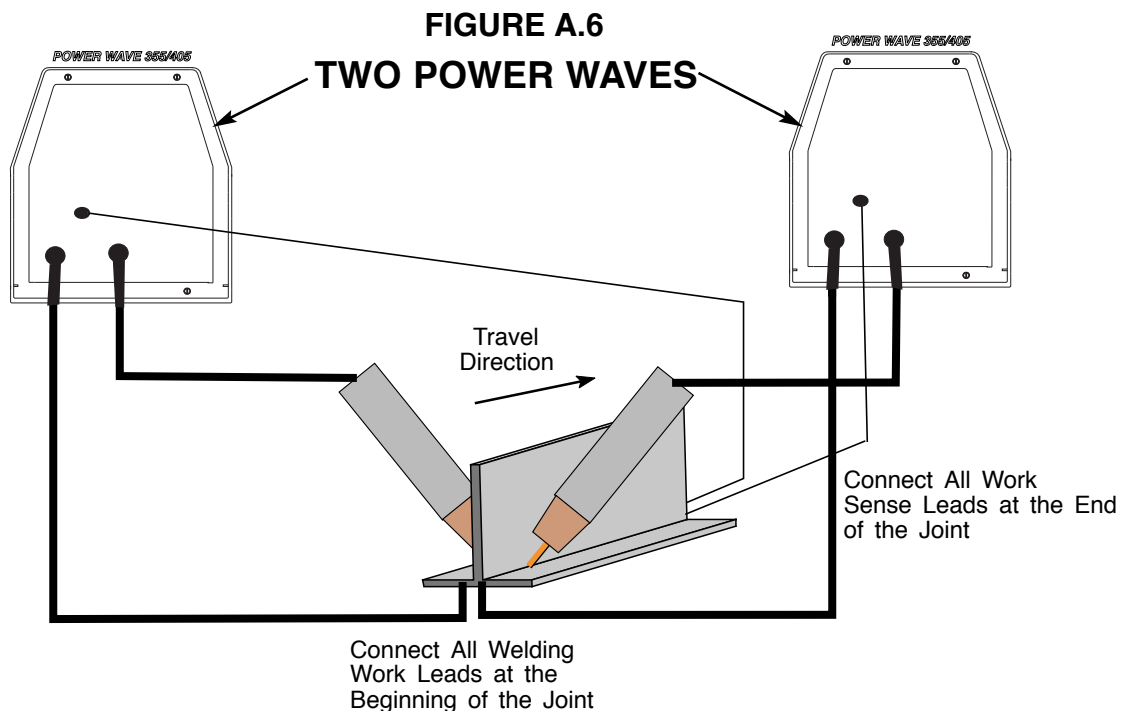

POWER WAVE® 355/405



INSTALLATION

I / O RECEPTACLE SPECIFICATIONS

TABLE A.2

WIRE FEEDER RECEPTACLE		
PIN	LEAD#	FUNCTION
A	53	Communication Bus L
B	54	Communication Bus H
C	67A	Electrode Voltage Sense
D	52	0vdc
E	51	+40vdc

TABLE A.3

VOLTAGE SENSE RECEPTACLE		
PIN	LEAD#	FUNCTION
3	21A	Work Voltage Sense

TABLE A.4
RS232 RECEPTACLE

PIN	LEAD#	FUNCTION
2	253	RS232 Receive
3	254	RS232 Transmit
4	#	Pin5
5	#	Pin4
6	# #	Pin20
20	# #	Pin6
7	251	RS232 Common

DIP SWITCH SETTINGS AND LOCATIONS

DIP switches on the P.C. Boards allow for custom configuration of the Power Wave. To access the DIP switches:

⚠ WARNING

1. Turn off power to the power source at the disconnect switch.
2. Remove the wrap around cover from the power source.
3. The control board is on the center assembly facing the case front. Locate the 8-position DIP switch and look for switch 8 of the DIP switch.
4. Using a pencil or other small object, slide the switch to the OFF position if the work sense lead is NOT connected. Conversely, slide the switch to the ON position if the work sense lead is present.

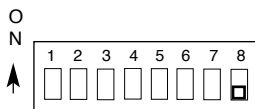

5. Replace the wrap around and screws. The PC board will “read” the switch at power up, and configure the work voltage sense lead appropriately.

CONTROL BOARD DIP SWITCH:

switch 1 = reserved for future use
 switch 2 = reserved for future use
 switch 3 = reserved for future use
 switch 4 = reserved for future use
 switch 5 = reserved for future use
 switch 6 = reserved for future use
 switch 7 = reserved for future use
 switch 8* = work sense lead

switch 8*	work sense lead
off	work sense lead not connected
on	work sense lead connected

*Factory setting for Switch 8 is OFF.

FIGURE A.7
CONTROL BOARD (DIP Switch Location)

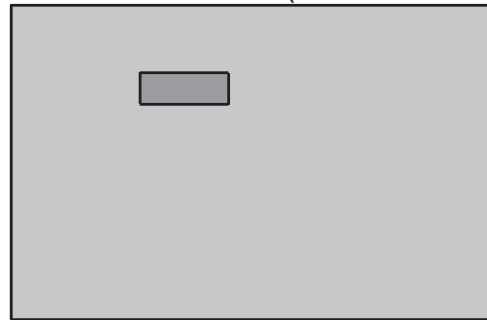

Return to Section TOC
Return to Master TOC

TABLE OF CONTENTS - OPERATION SECTION -

Operation	Section B
Safety Precautions	B-2
General Description	B-2
Recommended Processes and Equipment.....	B-2
Required Equipment	B-3
Limitations	B-3
Duty Cycle and Time Period	B-3
Case Front Controls.....	B-3
Making a Weld	B-4
Welding Adjustments.....	B-4
Constant Voltage Welding.....	B-5
Tig (GTAW).....	B-6
Special Welding Processes Available	B-6
Power Mode	B-6
Pulse Welding (GMAW-P).....	B-7
Pulse-on-Pulse (GMAW-PP).....	B-8
Benefits of Pulse-on-Pulse Welding.....	B-8

Return to Master TOC

Return to Master TOC

Return to Master TOC

Return to Master TOC

SAFETY PRECAUTIONS

Read this entire section of operating instructions before operating the machine.

WARNING

ELECTRIC SHOCK can kill.



- Unless using cold feed feature, when feeding with gun trigger, the electrode and drive mechanism are always electrically energized and could remain energized several seconds after the welding ceases.

- Do not touch electrically live parts or electrodes with your skin or wet clothing.
- Insulate yourself from the work and ground.
- Always wear dry insulating gloves.

FUMES AND GASES can be dangerous.



- Keep your head out of fumes.
- Use ventilation or exhaust to remove fumes from breathing zone.

WELDING SPARKS can cause fire or explosion.

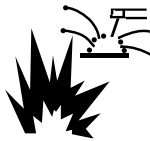

- Keep flammable material away.
- Do not weld on containers that have held combustibles.

ARC RAYS can burn.



- Wear eye, ear, and body protection.

Observe additional guidelines detailed in the beginning of this manual.

GENERAL DESCRIPTION

The Power Wave semi-automatic power source is designed to be a part of a modular, multi-process welding system. Depending on configuration, it can support constant current, constant voltage, and pulse welding modes.

The Power Wave power source is designed to be used with the semi automatic family of Power Feed wire feeders, operating as a system. Each component in the system has special circuitry to "talk with" the other system components, so each component (power source, wire feeder, user interface) knows what the other is doing at all times. These components communicate with Linc-Net.

The POWER WAVE® 355/405 is a high performance, digitally controlled inverter welding power source capable of complex, high-speed waveform control. Properly equipped, it can support the GMAW, GMAW-P, FCAW, SMAW, GTAW, and CAC-A processes. It carries an output rating of 350 Amps, 34 Volts at 60% duty cycle and 300 Amps, 32 volts at 100% duty cycle.

RECOMMENDED PROCESSES AND EQUIPMENT

RECOMMENDED PROCESSES

The POWER WAVE® 355/405 can be set up in a number of configurations, some requiring optional equipment or welding programs. Each machine is factory preprogrammed with multiple welding procedures, typically including GMAW, GMAW-P, FCAW, GTAW, and CAC-A for a variety of materials, including mild steel, stainless steel, cored wires, and aluminum.

The POWER WAVE® 355/405 is recommended for semi-automatic welding, and may also be suitable for basic hard automation applications.

- This Power Wave is not recommended for processes other than those listed.

POWER WAVE® 355/405



OPERATION

POWER WAVE® 355/405 – Semi-Automatic Operation

Semi Automatic Power Waves can only be used with Linc-Net compatible Power Feed semi-automatic wire feeders. In addition, the Power Feed semi-automatic wire feeders may require optional equipment to access certain weld modes in the Power Wave. Other models of Lincoln feeders, or any models of non-Lincoln wire feeders, cannot be used.

All welding programs and procedures are selected through the Power Feed semi-automatic user interface

REQUIRED EQUIPMENT

Any Linc-Net compatible semi-automatic wire feeding equipment. Specifically, the semi-automatic Power Feed family (PF-10, PF-10X2, PF-11).

LIMITATIONS

- Only Linc-Net compatible Power Feed semi-automatic wire feeders and users interfaces may be used. Other Lincoln wire feeders or non-Lincoln wire feeders cannot be used.
- POWER WAVE® 355/405 Output Limitations
The POWER WAVE® 355/405 will support maximum average output current of 350 Amps @ 60% duty cycle.

DUTY CYCLE AND TIME PERIOD

The duty cycle is based upon a ten minute period. A 60% duty cycle represents 6 minutes of welding and 4 minutes of idling in a ten minute period.

CASE FRONT CONTROLS

All operator controls and adjustments are located on the case front of the Power Wave. (*See Figure B.1*)

1. POWER SWITCH: Controls input power to the Power Wave.
2. STATUS LIGHT: A two color light that indicates system errors. Normal operation is a steady green light. Error conditions are indicated, **per table B.1**.

NOTE: The POWER WAVE® 355/405 status light will flash green, and sometimes red and green, for up to one minute when the machine is first turned on. This is a normal situation as the machine goes through a self test at power up.

TABLE B.1

Light Condition	Meaning
Steady Green	System OK. Power source communicating normally with wire feeder and its components.
Blinking Green	Occurs during a reset, and indicates the POWER WAVE® 355/405 is mapping (identifying) each component in the system. Normal for first 1-10 seconds after power is turned on, or if the system configuration is changed during operation
Alternating Green and Red	Non-recoverable system fault. If the PW Status light is flashing any combination of red and green, errors are present in the POWER WAVE® 355/405. Read the error code before the machine is turned off. Error Code interpretation through the Status light is detailed in the LED Status Chart . Individual code digits are flashed in red with a long pause between digits. If more than one code is present, the codes will be separated by a green light. To clear the error, turn power source off, and back on to reset.
Steady Red	Non recoverable hardware fault. Generally indicates nothing is connected to the POWER WAVE® 355/405 wire feeder receptacle. See Trouble Shooting Section.
Blinking Red	Not applicable.

3. HIGH TEMPERATURE LIGHT (thermal overload):
A yellow light that comes on when an over temperature situation occurs. Output is disabled and the fan continues to run, until the machine cools down. When cool, the light goes out and output is enabled.
4. CB1 WIRE FEEDER CIRCUIT BREAKER:
Protects 40 volt DC wire feeder power supply.

FIGURE B.1

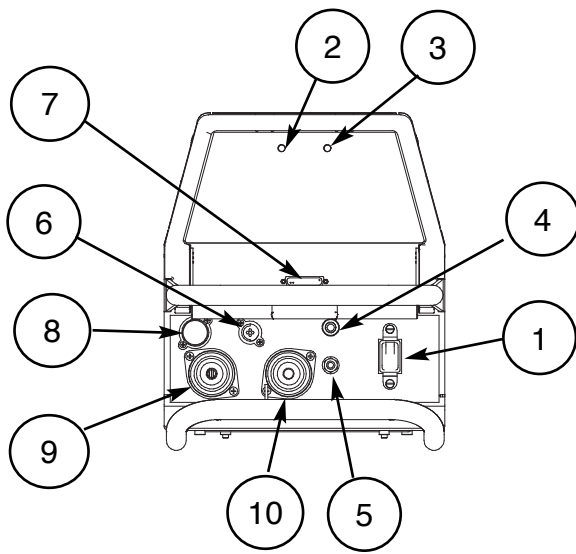

CASE FRONT LAYOUT POWER WAVE® 355/405

5. Internal POWER CIRCUIT BREAKER: Protects 115 volt AC circuit.
6. LEAD CONNECTOR (SENSE LEAD)
7. DIAGNOSTIC CONNECTOR (RS-232)
8. WIRE FEEDER RECEPTACLE (5-PIN)
9. NEGATIVE TWIST- MATE TERMINAL
10. POSITIVE TWIST- MATE TERMINAL

NOMINAL PROCEDURES

The Power Wave is designed to operate with 3/4" electrode stick-out for CV and Pulse processes.

FRINGE PROCEDURES

Excessively short or long electrode stick-outs may function only on a limited basis, if at all.

MAKING A WELD

⚠ WARNING

The serviceability of a product or structure utilizing the welding programs is and must be the sole responsibility of the builder/user. Many variables beyond the control of The Lincoln Electric Company affect the results obtained in applying these programs. These variables include, but are not limited to, welding procedure, plate chemistry and temperature, weldment design, fabrication methods and service requirements. The available range of a welding program may not be suitable for all applications, and the build/user is and must be solely responsible for welding program selection.

The steps for operating the Power Wave will vary depending upon the options installed in the user interface (control box) of the welding system. The flexibility of the Power Wave system lets the user customize operation for the best performance.

First, consider the desired welding process and the part to be welded. Choose an electrode material, diameter, shielding gas and process (GMAW, GMAW-P, etc.)

Second, find the program in the welding software that best matches the desired welding process. The standard software shipped with the Power Waves encompasses a wide range of common processes and will meet most needs. If a special welding program is desired, contact the local Lincoln Electric sales representative.

To make a weld, the Power Wave needs to know the desired welding parameters. The Power Feed (PF) family of feeders communicate settings to the Power Wave through control cable connection. Arc length, wire feed speed, arc control, etc. are all communicated digitally via the control cable.

WELDING ADJUSTMENTS

All adjustments are made on the system component known as the User Interface (Control Box), which contains the switches, knobs, and digital displays necessary to control both the Power Wave and a Power Feed wire feeder. Typically, the Control Box is supplied as part of the wire feeder. It can be mounted directly on the wire feeder itself, the front of the power source, or mounted separately, as might be done in a welding boom installation.

Because the Control Box can be configured with many different options, your system may not have all of the following adjustments. Regardless of availability, all controls are described below. For further information, consult the Power Feed wire feeder instruction manual.

• WFS / AMPS:

In synergic welding modes (synergic CV, pulse GMAW) WFS (wire feed speed) is the dominant control parameter, controlling all other variables. The user adjusts WFS according to factors such as weld size, penetration requirements, heat input, etc. The Power Wave then uses the WFS setting to adjust its output characteristics (output voltage, output current) according to pre-programmed settings contained in the Power Wave.

POWER WAVE® 355/405



OPERATION

In non-synergic modes, the WFS control behaves more like a conventional CV power source where WFS and voltage are independent adjustments. Therefore to maintain the arc characteristics, the operator must adjust the voltage to compensate for any changes made to the WFS.

In constant current modes (stick, TIG) this control adjusts the output current, in amps.

• VOLTS / TRIM:

In constant voltage modes (synergic CV, standard CV) the control adjusts the welding voltage.

In pulse synergic welding modes (pulse GMAW only) the user can change the Trim setting to adjust the arc length. It is adjustable from 0.500 to 1.500. A Trim setting of 1.000 is a good starting point for most conditions.

• WELDING MODE

May be selected by name (CV/MIG, CC/Stick Crisp, Gouge, etc.) or by a mode number (10, 24, 71, etc.) depending on the Control Box options. Selecting a welding mode determines the output characteristics of the Power Wave power source. For a more complete description of the welding modes available in the Power Wave, see the explanation below.

• ARC CONTROL

Also known as Inductance or Wave Control. Allows operator to vary the arc characteristics from "soft" to "harsh" in all weld modes. It is adjustable from -10.0 to +10.0, with a nominal setting of 00.0 (The nominal setting of 00.0 may be displayed as OFF on some Power Feed wire feeder control panels). See the Welding Mode descriptions, below, for detailed explanations of how the Arc Control affects each mode.

CONSTANT VOLTAGE WELDING

Synergic CV:

For each wire feed speed, a corresponding voltage is preprogrammed into the machine through special software at the factory. The nominal preprogrammed voltage is the best average voltage for a given wire feed speed, but may be adjusted to preference. When the wire feed speed changes, the Power Wave automatically adjusts the voltage level correspondingly to maintain similar arc characteristics throughout the WFS range.

Non Synergic CV:

This type of CV mode behaves more like a conventional CV power source. Voltage and WFS are independent adjustments. Therefore to maintain the arc characteristics, the operator must adjust the voltage to compensate for any changes made to the WFS.

All CV Modes:

Arc Control, often referred to as wave control, adjusts the inductance of the wave shape. The wave control adjustment is similar to the "pinch" function in that it is inversely proportional to inductance. Therefore, increasing wave control greater than 0.0 results in a harsher, colder arc while decreasing the wave control to less than 0.0 provides a softer, hotter arc. (See Figure B.2)

FIGURE B.2

CURRENT WAVE FORM (CV)

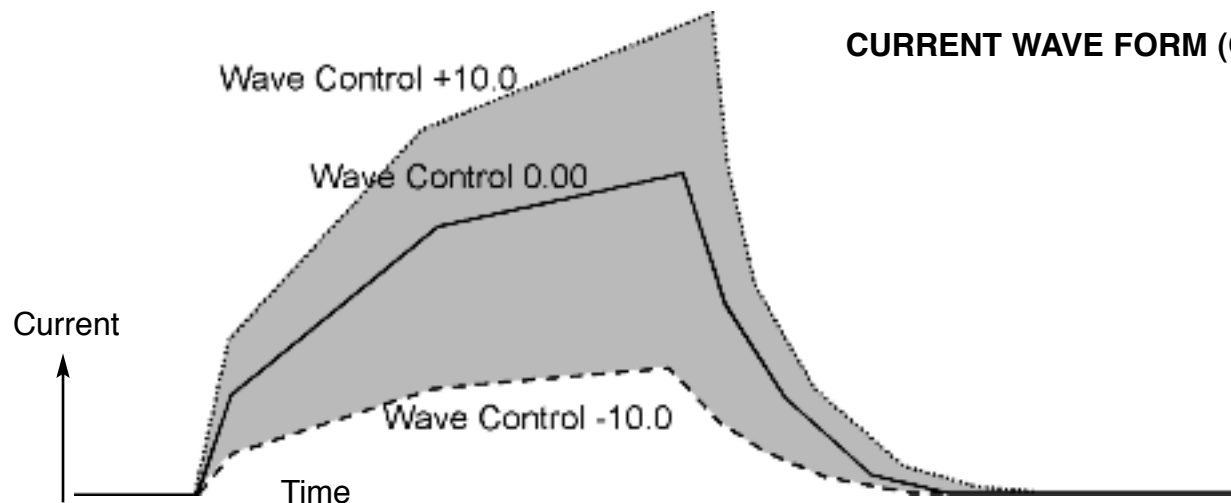

POWER WAVE® 355/405

LINCOLN
ELECTRIC

OPERATION

TIG GTAW

The TIG mode features continuous control from 5 to 425 amps. The TIG mode can be run in either the Touch Start TIG or Scratch start mode.

The Arc Control level selects the starting mode.

Between -10 and 0, the Touch Start TIG mode is selected. The OCV is controlled below 10V and the short circuit "TIG touch" current is maintained at approximately 25 amps, independent of the preset current. When the tungsten is lifted, an arc is initiated and the output is regulated at the preset value. A setting of 0, results in the most positive arc initiation. A setting of -10 reduces hot start.

Between 0 and 10, the Scratch starting TIG mode is selected. In this range, the OCV of the machine is controlled between 50 and 70 volts.

SPECIAL WELDING PROCESSES AVAILABLE ON THIS MACHINE

POWER MODE™

The Power Mode™ process was developed by Lincoln to maintain a stable and smooth arc at low procedure settings which are needed to weld thin metal without pop-outs or burning-through. For Aluminum welding, it provides excellent control and the ability to maintain constant arc length. This results in improved welding performance in two primary types of applications.

- Short Arc MIG at low procedure settings.
- Aluminum MIG welding.

Power Mode™ is a method of high speed regulation of the output power whenever an arc is established. It provides a fast response to changes in the arc. The higher the Power Mode Setting, the longer the arc. If a welding procedure is not established, the best way to determine the Power Mode Setting is by experimentation until the desired output result is established.

In the Power Mode variables need to be set:

- Wire Feed Speed
- Output
- Arc Control

Setting up a Power Mode procedure is similar to setting a CV MIG procedure. Select a shielding gas appropriate for a short arc process.

- For steel, use 75/25 Ar/CO2 shield gas.
- For Stainless, select a Helium blend Tri-Mix.
- For Aluminum, use 100% Ar.

Start by setting the wire feed speed based upon material thickness and appropriate travel speed. Then adjust the Output knob as follows:

- For steel, listen for the traditional “frying egg” sound of a good short-arc MIG procedure to know you have the process set correctly.
- For aluminum, simply adjust the Output knob until the desired arc length is obtained.

Note the Volts display is simply a relative number and DOES NOT correspond to voltage.

Some procedure recommendations appear in the table below.

Recommended Welding Procedures for Power Mode

MATERIAL	Aluminum 4043	Aluminum 5356	Mild Steel	Mild Steel	Mild Steel	Mild Steel	Mild Steel	Mild Steel	Mild Steel	Stainless Steel	Stainless Steel
W RE	E4043	E5356	L56	L56	L56	L56	L56	L56	L56	E308L	E308L
W RE SI ZE	0.035	0.035	0.025	0.025	0.030	0.030	0.035	0.035	0.035	0.030	0.035
GAS	100% Ar.	100% Ar.	100% CO ₂	75/25% Ar/CO ₂	100% CO ₂	75/25% Ar/CO ₂	100% CO ₂	75/25% Ar/CO ₂	75/25% Ar/CO ₂	Tri-mix	Tri-mix
MATERIAL THICKNESS WFS / POWER MODE SETTING	22 ga.	125 / 2.25	125 / 1.75	Not Recommended	100 / 0.8	Not Recommended	90 / 1.0				
	20 ga.	150 / 2.5	150 / 2.3	120 / 1.0	120 / 1.0	100 / 0.7	100 / 1.0			80 / 1.5	50 / 0.5
	18 ga.	200 / 3.75	200 / 3.0	140 / 1.7	140 / 1.5	110 / 1.5	110 / 1.5	100 / 2.5	100 / 2.5	110 / 2.0	110 / 2.0
	16 ga.	300 / 7.75	300 / 6.85	190 / 2.0	190 / 2.0	125 / 2.0	125 / 2.0	125 / 3.0	125 / 3.0	140 / 2.5	130 / 2.7
	14 ga.	400 / 9.0	400 / 7.5	260 / 3.0	260 / 3.0	160 / 2.3	160 / 2.3	160 / 3.8	160 / 3.5	210 / 3.0	190 / 3.5
	12 ga.	450 / 9.5	450 / 8.0	330 / 5.0	330 / 4.5	230 / 3.5	230 / 3.5	200 / 5.0	200 / 4.5	270 / 5.0	230 / 6.0
	10 ga.	500 / 10.0	500 / 8.5			300 / 6.0	300 / 6.0	240 / 6.5	240 / 7.0	325 / 6.5	300 / 7.0
	3/16	600 / 11.25	600 / 9.5			400 / 7.5	400 / 7.0				
	1/4		700 / 11								

POWER WAVE® 355/405



Return to Section TOC

Return to Master TOC

OPERATION

PULSE WELDING (GMAW-P)

The pulsed-arc process is, by definition, a spray transfer process wherein spray transfer occurs in pulses at regularly spaced intervals. In the time between pulses, the welding current is reduced and no metal transfer occurs.

Pulsed-arc transfer is obtained by operating a power source between low and high current levels. The high current level or "pulse" forces an electrode drop to the workpiece. The low current level or "background" maintains the arc between pulses. (See Figure B.3).

Pulsed MIG is an advanced form of welding that takes the best of all the other forms of transfer while minimizing or eliminating their disadvantages. Unlike short circuit, pulsed MIG does not create spatter or run the risk of cold lapping. The welding positions in pulsed MIG are not limited as they are with globular or spray and its wire use is definitely more efficient. Unlike the spray arc process, pulsing offers controlled heat input that allows better welding on thin materials, lower wire feed speeds and leads to less distortion and improved overall quality and appearance. This is especially important with stainless, nickel and other alloys that are sensitive to heat input.

In **GMAW-P mode**, arc control adjusts the background current and frequency of the wave. When arc control goes up, the frequency increases thus increasing the droplet transfer.

FIGURE B.3

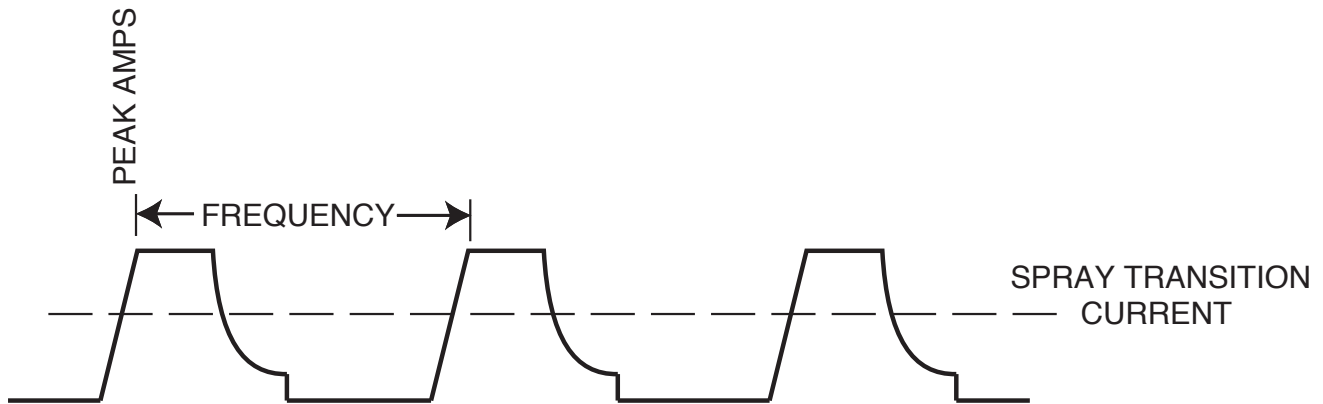
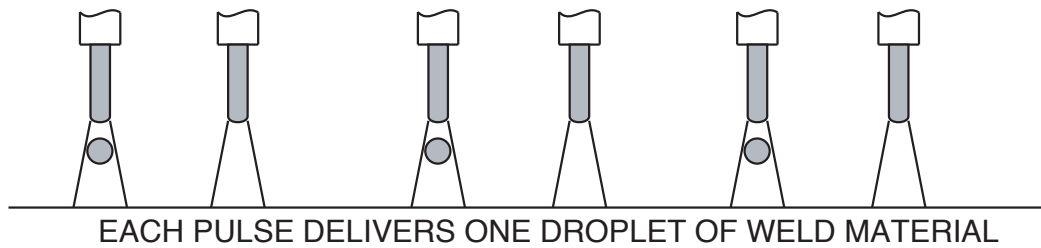

[Return to Section TOC](#)
[Return to Master TOC](#)
[Return to Section TOC](#)
[Return to Master TOC](#)
[Return to Section TOC](#)
[Return to Master TOC](#)
[Return to Section TOC](#)
[Return to Master TOC](#)

OPERATION

PULSE-ON-PULSE™ (GMAW-PP)

Pulse on Pulse™ is a Lincoln process specifically designed for use in welding relatively thin (less than 1/4" thick) aluminum (See the table below). It gives weld beads with very consistent uniform ripple.

In Pulse on Pulse modes, two distinct pulse types are used, instead of the single pulse type normally used in GMAW-P. A number of high energy pulses are used to obtain spray transfer and transfer metal across the arc. Such pulses are shown in the figure below. After a number "N" of such pulses, depending on the wire feed speed used, an identical number "N" of low energy pulses are performed. These low energy pulses, shown in the figure below, do not transfer any filler metal across the arc and help to cool the arc and keep the heat input low.

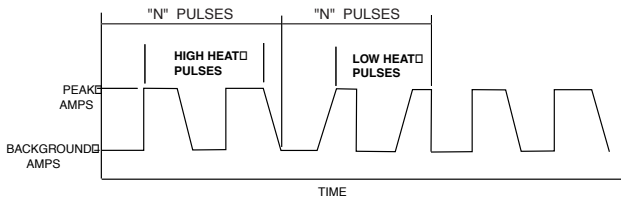

The Peak Current, Background Current, and Frequency are identical for the high energy and low energy pulses. In addition to cooling the weld down, the major effect of the low energy pulses is that they form a weld ripple. Since they occur at very regular time intervals, the weld bead obtained is very uniform with a very consistent ripple pattern. In fact, the bead has its best appearance if no oscillation of the welding gun ("whipping") is used. (See the figure below)

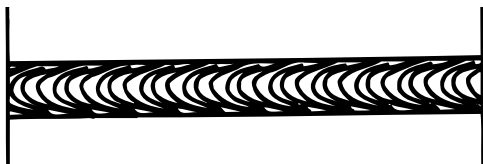

When Arc Control is used in the Pulse on Pulse modes, it does the same things it does in the other pulsed modes: decreasing the Arc Control decreases the droplet transfer and weld deposition rate. Increasing the Arc Control increases the droplet transfer and weld deposition rate. Since Arc Control varies weld droplet transfer rate, the Arc Control can be used to vary the ripple spacing in the weld bead.

BENEFITS OF PULSE ON PULSE FROM LINCOLN ELECTRIC

- Excellent appearance of the weld bead
- Improved cleaning action
- Reduced porosity

Table B.2 shows WFS and Trim settings for common aluminum types and wire sizes when welding with Pulse-on-Pulse. The welds made to obtain the values in the table were fillet welds in the flat position. The values in the table can be helpful as a starting point to establish a welding procedure. From there, adjustments need to be made to set the proper procedure for each specific application (out-of-position, other types of joints, etc.).

The comments on the table below show values of WFS below which it is not recommended to weld. The reason is, that below these values the weld transfer will change from a spray arc to a short-arc, which is not advisable when welding aluminum.

WELDING PROCEDURES FOR PULSE-ON-PULSE

MATERIAL	Aluminum 4043	Aluminum 4043	Aluminum 5356	Aluminum 5356
GAS	100% Ar.	100% Ar.	100% Ar.	100% Ar.
WIRE	E4043	E4043	E5356	E5356
WIRE SIZE	0.035	3/64	0.035	3/64
MATERIAL THICKNESS WFS / ARC CONTROL	14 ga.	250 / 0	200 / 0	230 / 0
	10 ga.	400 / 0	280 / 0	425 / 0
	3/16	550 / 0	340 / 0	670 / 0
	1/4	600 / 0	400 / 0	700 / 0
COMMENTS	Not Recommended below 200 WFS	Not Recommended below 100 WFS	Not Recommended below 200 WFS	Not Recommended below 200 WFS

POWER WAVE® 355/405



[Return to Section TOC](#) [Return to Master TOC](#)

TABLE OF CONTENTS - ACCESSORIES SECTION -

AccessoriesSection C

Optional EquipmentC-2
 Field InstalledC-2
 Compatible Lincoln Equipment.....C-2

Return to Master TOC

Return to Master TOC

Return to Master TOC

Return to Master TOC

ACCESSORIES

OPTIONAL EQUIPMENT

FACTORY INSTALLED

None Available.

FIELD INSTALLED

K940-Work Voltage Sense Lead Kit

K1764-1-Undercarriage*

K1838-1-Valet Style Undercarriage

K1796-Coaxial Welding Cable-(Requires Adapter K2176-1)

K2176-1 Twist-mate to Lug Adapters

* Dual Cylinder Kit for K1764-1 is K1702-1

Welding Cable Connectors:

K852-70 1/0-2/0 CABLE

K852-95 2/0-3/0 CABLE

COMPATIBLE LINCOLN EQUIPMENT

Any Linc-Net compatible semi-automatic wire feeding equipment. Specifically, the semi-automatic Power Feed family (PF-10, PF-10X2, PF-11).

POWER WAVE® 355/405



Return to Section TOC

Return to Master TOC

Return to Section TOC

Return to Master TOC

Return to Section TOC

Return to Master TOC

Return to Section TOC

Return to Master TOC

TABLE OF CONTENTS -MAINTENANCE-

Maintenance	Section D
Capacitor Discharge Procedure	D-2
Visual Inspection	D-2
Routine Maintenance	D-2
Periodic Maintenance	D-2
Major Component Locations	D-3

Return to Master TOC

Return to Master TOC

Return to Master TOC

Return to Master TOC

MAINTENANCE

⚠ WARNING

Have qualified personnel do the maintenance work. Always use the greatest care when working near moving parts.

Do not put your hands near the cooling blower fan. If a problem cannot be corrected by following the instructions, take the machine to the nearest Lincoln Field Service Shop.



ELECTRIC SHOCK can kill.

- Do not touch electrically live parts or electrode with skin or wet clothing.
- Insulate yourself from work and ground
- Always wear dry insulating gloves.



EXPLODING PARTS can cause injury.

- Failed parts can explode or cause other parts to explode when power is applied.
- Always wear a face shield and long sleeves when servicing.

See additional warning information throughout this Manual.

CAPACITOR DISCHARGE PROCEDURE

1. Obtain a power resistor (25 ohms, 25 watts).
2. Hold resistor body with electrically insulated glove. DO NOT TOUCH TERMINALS. Connect the resistor terminals across the two studs in the position shown. Hold in each position for 1 second. Repeat for all four capacitors.

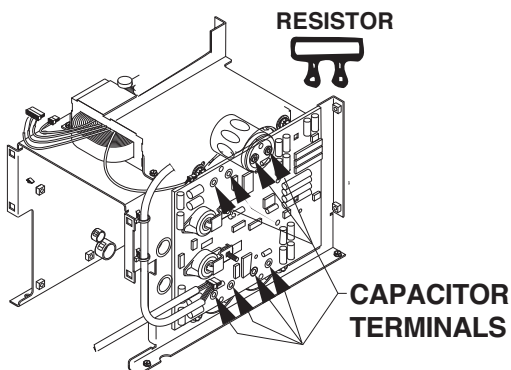

3. Use a DC voltmeter to check that voltage is not present across the terminals on all four capacitors.

VISUAL INSPECTION

Clean interior of machine with a low pressure air stream. Make a thorough inspection of all components. Look for signs of overheating, broken leads or other obvious problems. Many problems can be uncovered with a good visual inspection.

ROUTINE MAINTENANCE

1. Every 6 months or so the machine should be cleaned with a low pressure airstream. Keeping the machine clean will result in cooler operation and higher reliability. Be sure to clean these areas:
 - All printed circuit boards
 - Power switch
 - Main transformer
 - Input rectifier
 - Auxiliary Transformer
 - Reconnect Switch Area
 - Fan (Blow air through the rear louvers)
2. Examine the sheet metal case for dents or breakage. Repair the case as required. Keep the case in good condition to insure that high voltage parts are protected and correct spacings are maintained. All external sheet metal screws must be in place to insure case strength and electrical ground continuity.

PERIODIC MAINTENANCE

Calibration of the POWER WAVE® 355/405 is critical to its operation. Generally speaking the calibration will not need adjustment. However, neglected or improperly calibrated machines may not yield satisfactory weld performance. To ensure optimal performance, the calibration of output Voltage and Current should be checked yearly.

POWER WAVE® 355/405



MAINTENANCE

FIGURE D.1 – MAJOR COMPONENT LOCATIONS

- 1. Center Panel
- 2. Case Back
- 3. Case Front
- 4. Base Assembly
- 5. Case Wraparound

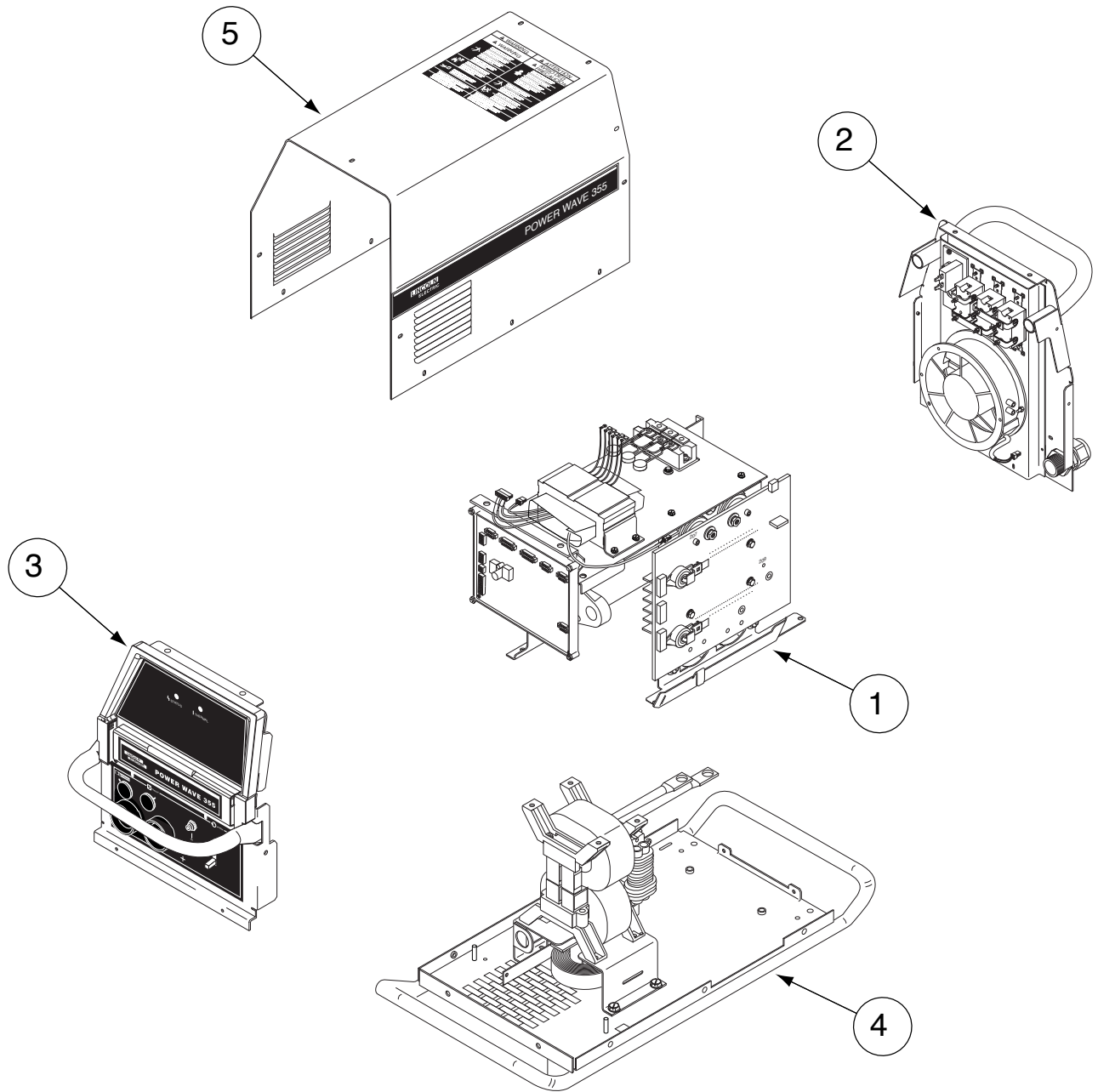

POWER WAVE® 355/405



Return to Section TOC
Return to Section TOC
Return to Section TOC
Return to Section TOC
Return to Master TOC
Return to Master TOC
Return to Master TOC
Return to Master TOC

NOTES

Return to Section TOC
Return to Master TOC

Return to Section TOC
Return to Master TOC

Return to Section TOC
Return to Master TOC

Return to Section TOC
Return to Master TOC

TABLE OF CONTENTS -THEORY OF OPERATION SECTION-

Theory of Operation	Section E
General Description	E-2
Input Line Voltage, Auxiliary Transformer and Precharge.....	E-2
Switch Board and Main Transformer.....	E-3
DC Bus Board, Power board and Control Board	E-4
Output Rectifier and Choke.....	E-5
Thermal Protection	E-6
Protective Circuits	E-6
Over current Protection	E-6
Under/Over Voltage Protection.....	E-6
Insulated Gate Bipolar Transistor (IGBT) Operation.....	E-7
Pulse Width Modulation	E-8
Minimum/Maximum Output.....	E-8

FIGURE E.1 – PW-355 BLOCK LOGIC DIAGRAM

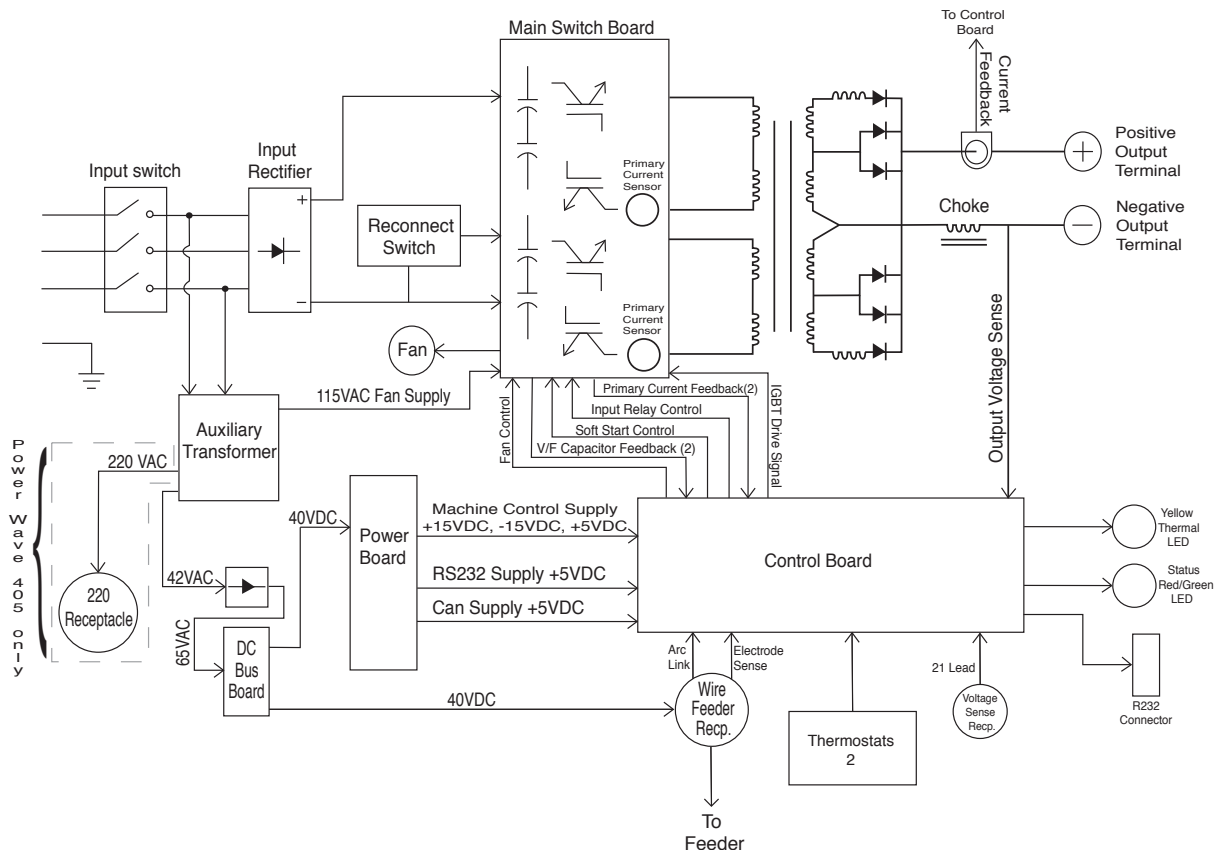

POWER WAVE® 355/405



Return to Master TOC

Return to Master TOC

Return to Master TOC

Return to Master TOC

THEORY OF OPERATION

FIGURE E.2 – INPUT VOLTAGE AND PRECHARGE

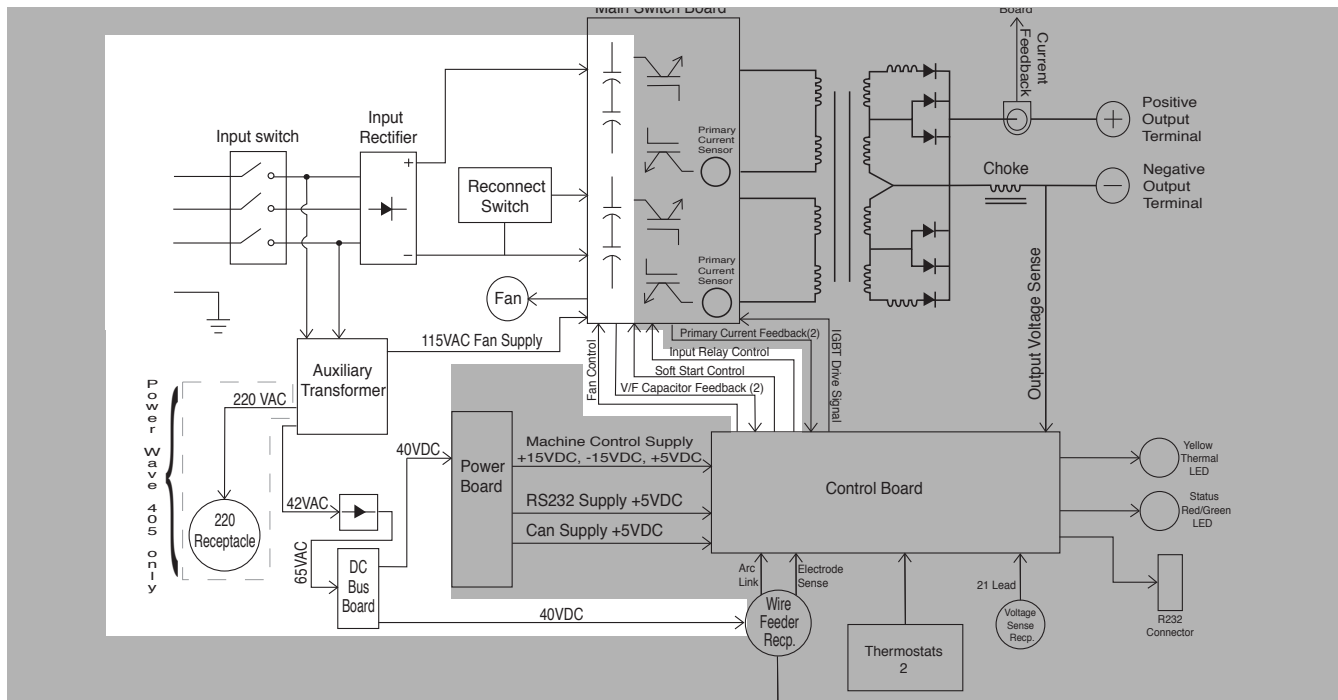

GENERAL DESCRIPTION

The Power Wave semi-automatic power source is designed to be a part of a modular, multi-process welding system. Depending on configuration, it can support constant current, constant voltage, and pulse welding modes.

The Power Wave power source is designed to be used with the semi-automatic family of power feed wire feeders, operating as a system. Each component in the system has special circuitry to “talk with” the other system components, so each component (power source, wire feeder, user interface) knows what the other is doing at all times. These components communicate with Linc-Net (a digital communications system).

The POWER WAVE® 355/405 is a high performance, digitally controlled inverter welding power source capable of complex, high speed waveform control. Properly equipped, it can support the GMAW, GMAW-P, FCAW, SMAW, GTAW, and CAC-A processes. It carries an output rating of 350 Amps, 34 Volts at 60% duty cycle and 300 Amps, 32 volts at 100% duty cycle.

INPUT LINE VOLTAGE, AUXILIARY TRANSFORMER, & PRECHARGE

The POWER WAVE® 355/405 can be connected for a variety of three-phase or single-phase input voltages. The initial power is applied to the 355/405 through a line switch located on the front of the machine. Two phases of the input voltage are applied to the auxiliary

transformer. The auxiliary transformer develops three different secondary voltages. The 115VAC is applied, via the main switch board, to the fan motor. The 42VAC is rectified and filtered. The 65VDC produced by the Bus board rectifier is used by the Bus board to provide 40VDC to the power board. 40VDC is also applied to the wire feeder receptacle. PW405 models have an additional 220VAC winding that is connected to a 220 AC receptacle.

The input voltage is rectified by the input rectifier and the resultant DC voltage is applied to the switch board through the reconnect switch assembly located at the rear of the machine. The reconnect switch connect the two pairs of input capacitors either in a parallel (lower voltage) or series (higher voltage) configuration to accommodate the applied input voltage.

During the precharge time the DC input voltage is applied to the input capacitors through a current limiting circuit. The input capacitors are charged slowly and current limited. A voltage to frequency converter circuit located on the switch board monitors the capacitor voltages. This signal is coupled to the control board. When the input capacitors have charged to an acceptable level, the control board energizes the input relays, that are located on the switch board, making all of the input power, without current limiting, available to the input capacitors. If the capacitors become under or over voltage the control board will de-energize the input relays and the 355/405 output will be disabled. Other possible faults may also cause the input relays to drop out.

POWER WAVE® 355/405

LINCOLN
ELECTRIC

THEORY OF OPERATION

FIGURE E.3 – SWITCH BOARD & MAIN TRANSFORMER

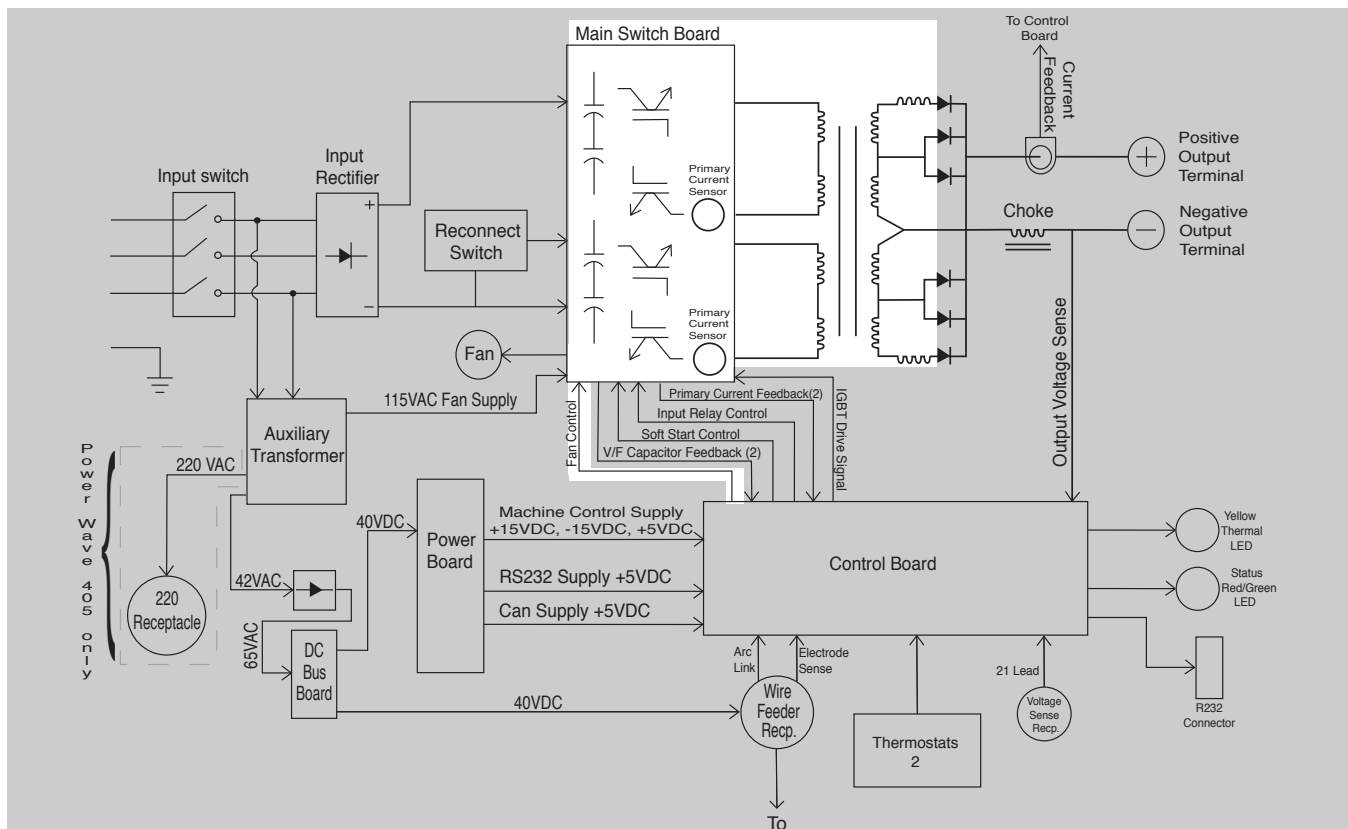

SWITCH BOARD & MAIN TRANSFORMER

There is one switch board in the POWER WAVE® 355/405. This board incorporates two pairs of input capacitors, two insulated gate bipolar transistor (IGBT) switching circuits, a fan motor drive circuit, and a voltage/frequency capacitor feedback circuit. The two capacitors in a pair are always in series with each other. When the reconnect switch is in the lower voltage position the capacitor pairs are in parallel. Thus two series capacitors in parallel with two series capacitors. When the reconnect switch is in the high voltage position the two capacitor pairs are in series. Thus four capacitors in series. This is required to accommodate the higher input voltages.

When the input capacitors are fully charged they act as power supplies for the IGBT switching circuits. When welding output is required the Insulated Gate Bipolar Transistors switch the DC power from the input capacitors, "on and off" thus supplying a pulsed DC current to the main transformer primary windings. **See IGBT Operation Discussion and Diagrams** in this section. Each IGBT switching circuit feeds current to a separate, oppositely wound primary winding in the main transformer. The reverse directions of current flow through the main transformer primaries and the offset timing of the IGBT switching circuits induce an AC square wave output signal at the secondary of the

main transformer. The two current transformers (CT) located on the switch board monitor these primary currents. If the primary currents become abnormally high the control board will shut off the IGBTs, thus disabling the machine output. The DC current flow through each primary winding is clamped back to each respective input capacitor when the IGBTs are turned off. This is needed due to the inductance of the transformer primary winding. The firing of the two switch boards occurs during halves of a 50 microsecond interval, creating a constant 20 KHZ output. In some low open circuit Tig modes the firing frequency is reduced to 5KHZ.

The POWER WAVE® 355/405 has a F.A.N. fan as needed circuit. The fan operates when the welding output terminals are energized or when a thermal over temperature condition exists. Once the fan is activated it will remain on for a minimum of five minutes. The fan driver circuit is housed on the switch board but it is activated from a control board signal.

THEORY OF OPERATION

FIGURE E.4 – POWER BOARD, CONTROL BOARD AND SERIAL PERIPHERAL INTERFACE (SPI) COMMUNICATIONS

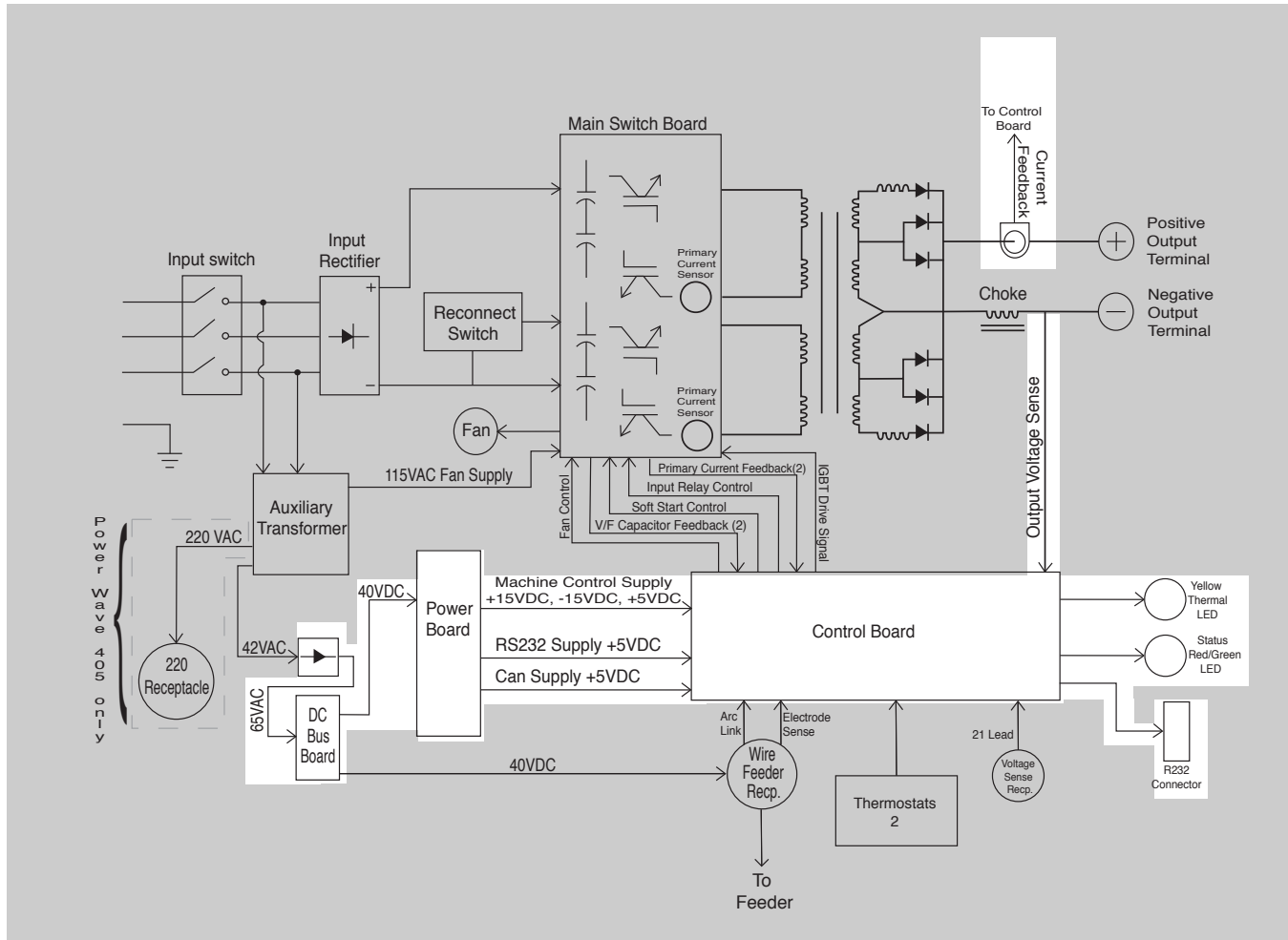

DC BUS BOARD, POWER BOARD AND CONTROL BOARD

DC BUS BOARD

The DC Bus Board receives approximately 65VDC from the bus board rectifier. The DC Bus Board regulates that 65VDC to a +40VDC supply. This regulated 40VDC is applied to the Power Board and the wire feed receptacles.

POWER BOARD

The power board, utilizing a switching power supply, processes the 40VDC input and develops several regulated positive and negative DC supplies. Three DC supplies are fed to the control board for machine control supplies. A +5VDC is used for the RS232 connection supply. Another +5VDC supply is utilized by the CAN digital communication circuitry. An over or under input voltage detection and shutdown circuit is also part of the power board's circuitry.

CONTROL BOARD

The Control Board performs the primary interfacing functions to establish and maintain output control of the POWER WAVE® 355/405. The function generator and weld files exist within the Control Board hardware and software. Digital command signals received from the user interface/feed head and feedback information received from the current sensor and output voltage sensing leads, are processed at the control board. Software within the control board processes the command and feedback information and sends the appropriate pulse width modulation (PWM) signals (See **PULSE WIDTH MODULATION** in this section) to the switch board IGBT's. In this manner, the digitally controlled high speed welding waveform is created.

In addition, the Control Board monitors the thermostats, the main transformer primary currents and input filter capacitor voltages. Depending on the fault condition, the Control Board will activate the thermal and/or the status light and will disable or reduce the machine's output.

POWER WAVE® 355/405

LINCOLN
ELECTRIC

THEORY OF OPERATION

FIGURE E.5 – OUTPUT RECTIFIER AND CHOKE

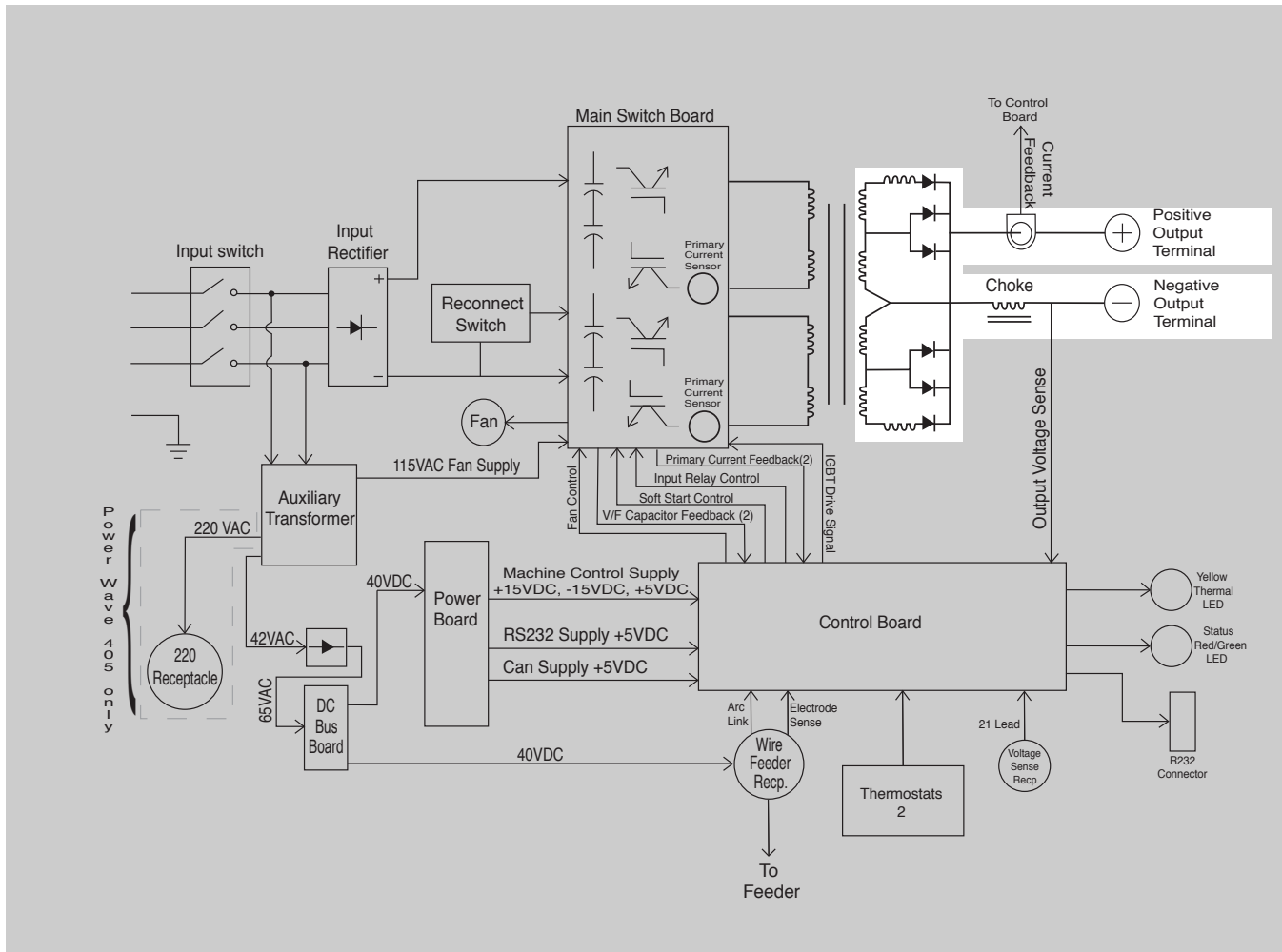

OUTPUT RECTIFIER AND CHOKE

The output rectifier receives the AC output from the main transformer secondary and rectifies it to a DC voltage level. Since the output choke is in series with the negative leg of the output rectifier and also in series with the welding load, a filtered DC output is applied to the machine's output terminals.

NOTE: Unshaded areas of Block Logic Diagram are the subject of discussion.

POWER WAVE® 355/405

LINCOLN
ELECTRIC

THEORY OF OPERATION

THERMAL PROTECTION

Three normally closed (NC) thermostats protect the machine from excessive operating temperatures. These thermostats are wired in series and are connected to the control board. One of the thermostats is located on the heat sink of the switch board, one is located on the output choke and the third thermostat is located on the DC Bus Board. Excessive temperatures may be caused by a lack of cooling air or operating the machine beyond its duty cycle or output rating. If excessive operating temperatures should occur, the thermostats will prevent output from the machine. The yellow thermal light, located on the front of the machine, will be illuminated. The thermostats are self-resetting once the machine cools sufficiently. If the thermostat shutdown was caused by excessive output or duty cycle and the fan is operating normally, the power switch may be left on and the reset should occur within a 15-minute period. If the fan is not turning or the air intake louvers are obstructed, then the power must be removed from the machine, and the fan problem or air obstruction corrected.

PROTECTIVE CIRCUITS

Protective circuits are designed into the POWER WAVE® 355/405 to sense trouble and shut down the machine before damage occurs to the machine's internal components.

OVER CURRENT PROTECTION

If the average current exceeds 450 amps for one second, then the output will be limited to 100 amps until the load is removed. If the peak current exceeds 600 amps for 150 ms, the output will be limited to 100 amps until the load is removed.

UNDER/OVER VOLTAGE PROTECTION

Protective circuits are included on the switch and control boards to monitor the voltage across the input capacitors. In the event that a capacitor pair voltage is too high, or too low, the machine output will be disabled. The protection circuits will prevent output if any of the following conditions exist.

1. Voltage across a capacitor pair exceeds 467 volts. (High line surges or improper input voltage connections.)
2. Voltage across a capacitor pair is under 190 volts. (Due to improper input voltage connections.)
3. Any major internal component damage.

THEORY OF OPERATION

INSULATED GATE BIPOLAR TRANSISTOR (IGBT) OPERATION

An IGBT is a type of transistor. IGBT are semiconductors well suited for high frequency switching and high current applications.

Example A in Figure E.6 shows an IGBT in passive mode. There is no gate signal, zero volts relative to the source, and therefore, no current flow. The drain terminal of the IGBT may be connected to a voltage supply; but since there is no conduction, the circuit will not supply current to components connected to the source. The circuit is turned OFF like a light switch.

Example B shows the IGBT in an active mode. When the gate signal, a positive DC voltage relative to the source, is applied to the gate terminal of the IGBT, it is capable of conducting current. A voltage supply connected to the drain terminal will allow the IGBT to conduct and supply current to the circuit components coupled to the source. Current will flow through the conducting IGBT to downstream components as long as the positive gate signal is present. This is similar to turning ON a light switch.

FIGURE E.6 – IGBT

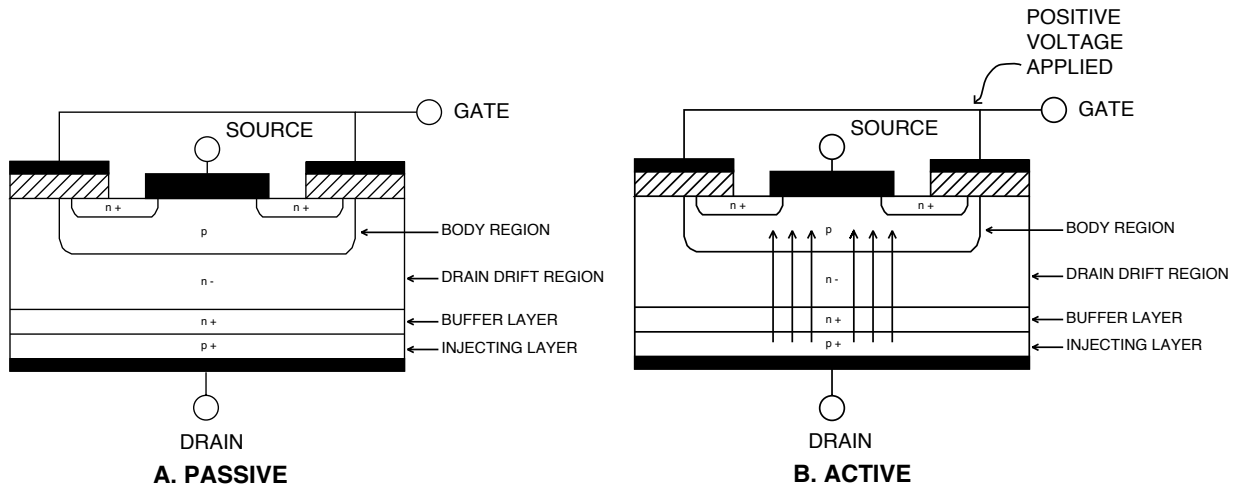

THEORY OF OPERATION

FIGURE E.7 – TYPICAL IGBT OUTPUTS.

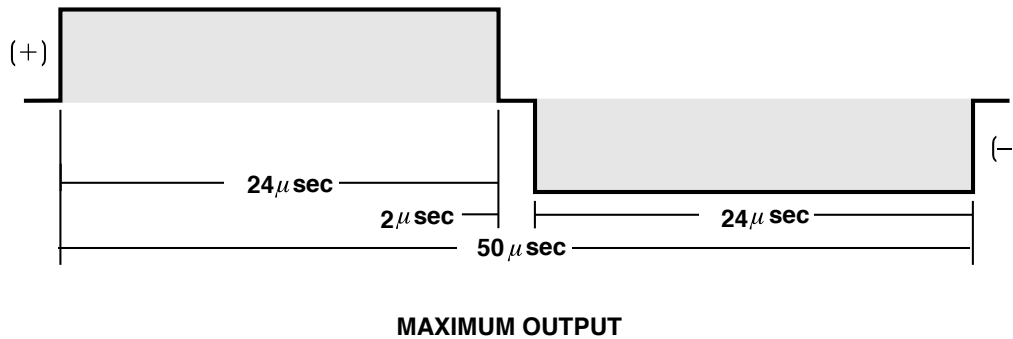
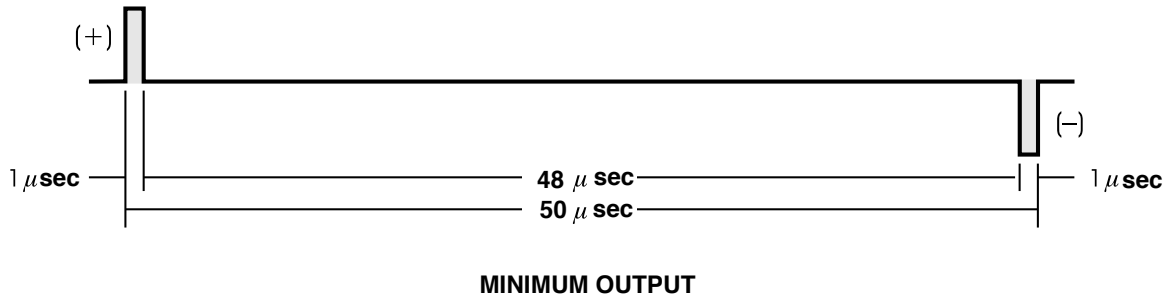

PULSE WIDTH MODULATION

The term Pulse Width Modulation is used to describe how much time is devoted to conduction in the positive and negative portions of the cycle. Changing the pulse width is known as modulation. Pulse Width Modulation (PWM) is the varying of the pulse width over the allowed range of a cycle to affect the output of the machine.

MINIMUM OUTPUT

By controlling the duration of the gate signal, the IGBT is turned on and off for different durations during the cycle. The top drawing in Figure E.7 shows the minimum output signal possible over a 50-microsecond time period.

The positive portion of the signal represents one IGBT group¹ conducting for one microsecond. The negative portion is the other IGBT group¹. The dwell time (off time) is 48 microseconds (both IGBT groups off). Since only two microseconds of the 50-microsecond time period is devoted to conducting, the output power is minimized.

MAXIMUM OUTPUT

By holding the gate signal on for 24 microseconds each, and allowing only two microseconds of dwell time (off time) during the 50-microsecond cycle, the output is maximized. The darkened area under the top curve can be compared to the area under the bottom curve. The more dark area that is under the curve indicates that more power is present.

¹An IGBT group consists of two IGBT modules feeding one transformer primary winding.

Return to Section TOC
Return to Master TOC

TABLE OF CONTENTS

TROUBLESHOOTING & REPAIR SECTION

Troubleshooting & Repair Section	Section F
How to Use Troubleshooting Guide	F-2
PC Board Troubleshooting Procedures and Replacement	F-3
Troubleshooting Guide	F-4/F-11
Test Procedures	
Input Filter Capacitor Discharge Procedure	F-13
Main Switch Board Test.....	F-15
Input Rectifier Test.....	F-21
Power Board Test	F-25
DC Bus Board Test.....	F-29
Output Diode Modules Test.....	F-33
Auxiliary Transformer Test.....	F-37
Current Transducer Test.....	F-41
Fan Control and Motor Test.....	F-45
Replacement Procedures	
Control Board Removal and Replacement.....	F-49
Main Switch Board Removal and Replacement.....	F-53
Snubber Board Removal and Replacement.....	F-57
Power Board Removal and Replacement	F-59
DC Bus Board Removal and Replacement.....	F-63
Input Rectifier Removal and Replacement.....	F-67
Output Rectifier Modules Removal and Replacement	F-71
Current Transducer Removal and Replacement.....	F-75
Retest after Repair	F-80

Return to Master TOC

Return to Master TOC

Return to Master TOC

Return to Master TOC

TROUBLESHOOTING & REPAIR

HOW TO USE TROUBLESHOOTING GUIDE



CAUTION

Service and repair should be performed by only Lincoln Electric Factory Trained Personnel. Unauthorized repairs performed on this equipment may result in danger to the technician and machine operator and will invalidate your factory warranty. For your safety and to avoid Electrical Shock, please observe all safety notes and precautions detailed throughout this manual.

This Troubleshooting Guide is provided to help you locate and repair possible machine malfunctions. Simply follow the three-step procedure listed below.

Step 1. LOCATE PROBLEM (SYMPTOM). Look under the column labeled “PROBLEM (SYMPTOMS)”. This column describes possible symptoms that the machine may exhibit. Find the listing that best describes the symptom that the machine is exhibiting. Symptoms are grouped into three main categories: Output Problems, Function Problems, and LED Function Problems.

Step 2. PERFORM EXTERNAL TESTS. The second column, labeled “POSSIBLE AREAS OF MISADJUSTMENT(S)”, lists the obvious external possibilities that may contribute to the machine symptom. Perform these tests/checks in the order listed. In general, these tests can be conducted without removing the case wrap-around cover.

Step 3. PERFORM COMPONENT TESTS. The last column, labeled “Recommended Course of Action” lists the most likely components that may have failed in your machine. It also specifies the appropriate test procedure to verify that the subject component is either good or bad. If there are a number of possible components, check the components in the order listed to eliminate one possibility at a time until you locate the cause of your problem.

All of the referenced test procedures referred to in the Troubleshooting Guide are described in detail at the end of this chapter. Refer to the Troubleshooting and Repair Table of Contents to locate each specific Test Procedure. All of the referred to test points, components, terminal strips, etc., can be found on the referenced electrical wiring diagrams and schematics. Refer to the Electrical Diagrams Section Table of Contents to locate the appropriate diagram.



CAUTION

If for any reason you do not understand the test procedures or are unable to perform the test/repairs safely, contact the Lincoln Electric Service Department for electrical troubleshooting assistance before you proceed. Call 1-888-935-3877

POWER WAVE® 355/405



TROUBLESHOOTING & REPAIR

PC BOARD TROUBLESHOOTING PROCEDURES

⚠ WARNING



ELECTRIC SHOCK can kill.

- Have an electrician install and service this equipment. Turn the input power OFF at the fuse box before working on equipment. Do not touch electrically hot parts.

⚠ CAUTION

Sometimes machine failures appear to be due to PC board failures. These problems can sometimes be traced to poor electrical connections. To avoid problems when troubleshooting and replacing PC boards, please use the following procedure:

1. Determine to the best of your technical ability that the PC board is the most likely component causing the failure symptom.
2. Check for loose connections at the PC board to assure that the PC board is properly connected.
3. If the problem persists, replace the suspect PC board using standard practices to avoid static electrical damage and electrical shock. Read the warning inside the static resistant bag and perform the following procedures:

PC board can be damaged by static electricity.



ATTENTION Static-Sensitive Devices Handle only at Static-Safe Workstations

- Remove your body's static charge before opening the static-shielding bag. Wear an anti-static wrist strap. For safety, use a 1 Meg ohm resistive cord connected to a grounded part of the equipment frame.

- If you don't have a wrist strap, touch an un-painted, grounded, part of the equipment frame. Keep touching the frame to prevent static build-up. Be sure not to touch any electrically live parts at the same time.

- Tools which come in contact with the PC board must be either conductive, anti-static or static-dissipative.

- Remove the PC board from the static-shielding bag and place it directly into the equipment. Don't set the PC board on or near paper, plastic or cloth which could have a static charge. If the PC board can't be installed immediately, put it back in the static-shielding bag.

- If the PC board uses protective shorting jumpers, don't remove them until installation is complete.

- If you return a PC board to The Lincoln Electric Company for credit, it must be in the static-shielding bag. This will prevent further damage and allow proper failure analysis.

4. Test the machine to determine if the failure symptom has been corrected by the replacement PC board.

NOTE: It is desirable to have a spare (known good) PC board available for PC board troubleshooting.

NOTE: Allow the machine to heat up so that all electrical components can reach their operating temperature.

5. Remove the replacement PC board and substitute it with the original PC board to recreate the original problem.

a. If the original problem does not reappear by substituting the original board, then the PC board was not the problem. Continue to look for bad connections in the control wiring harness, junction blocks, and terminal strips.

b. If the original problem is recreated by the substitution of the original board, then the PC board was the problem. Reinstall the replacement PC board and test the machine.

6. Always indicate that this procedure was followed when warranty reports are to be submitted.

NOTE: Following this procedure and writing on the warranty report, "INSTALLED AND SWITCHED PC BOARDS TO VERIFY PROBLEM," will help avoid denial of legitimate PC board warranty claims.

Observe Safety Guidelines detailed in the beginning of this manual.

TROUBLESHOOTING GUIDE

PROBLEMS (SYMPTOMS)	POSSIBLE AREAS OF MISADJUSTMENT(S)	RECOMMENDED COURSE OF ACTION
OUTPUT PROBLEMS		
Major physical or electrical damage is evident when the sheet metal cover is removed.	1. Contact your local authorized Lincoln Electric Field Service Facility for technical assistance.	1. Contact the Lincoln Electric Service Department, 1-888-935-3877.
The machine is dead—no output—no LEDs.	<ol style="list-style-type: none"> 1. Make sure the input line switch is in the ON position. 2. Check the main input line fuses. If open, replace. 3. Check the 15 amp circuit breaker (CB1). Reset if tripped. Also check CB3. 4. Make sure the reconnect switch and jumper lead is configured correctly for the applied input voltage. 5. If the machine is being operated with single phase input voltage make sure the correct lead is not connected. See the <i>Installation Section</i>. 	<ol style="list-style-type: none"> 1. Perform the <i>Auxiliary Transformer Test</i>. 2. Perform the <i>DC Bus Board Test</i>. 2. Perform the <i>Power Board Test</i>. 3. The Bus Board rectifier and or associated filter capacitor (C5) may be faulty. Check and replace as necessary. 4. The Control Board may be faulty.
The main input fuses (or breaker) repeatedly fail.	<ol style="list-style-type: none"> 1. Make certain the fuses or breakers are sized properly. 2. Make sure the reconnect switch and jumper lead is configured correctly for the applied input voltage. 3. The welding procedure may be drawing too much input current or the duty cycle may be too high. Reduce the welding current and/or reduce the duty cycle. 	<ol style="list-style-type: none"> 1. Check the reconnect switches and associated wiring. See the Wiring Diagram. 2. Perform the <i>Input Rectifier Test</i>. 3. Perform the <i>Main Switch Board Test</i>. 4. Perform the <i>Output Diode Module Test</i>. 5. The Input Filter Capacitors may be faulty. Check, and if any are faulty replace all four.



CAUTION

If for any reason you do not understand the test procedures or are unable to perform the test/repairs safely, contact the Lincoln Electric Service Department for electrical troubleshooting assistance before you proceed. Call 1-888-935-3877.

POWER WAVE® 355/405



Return to Section TOC
Return to Master TOC

Return to Section TOC
Return to Master TOC

Return to Section TOC
Return to Master TOC

Return to Section TOC
Return to Master TOC

TROUBLESHOOTING GUIDE

Observe Safety Guidelines detailed in the beginning of this manual.

PROBLEMS (SYMPTOMS)	POSSIBLE AREAS OF MISADJUSTMENT(S)	RECOMMENDED COURSE OF ACTION
OUTPUT PROBLEMS		
<p>The machine does not have welding output.</p>	<ol style="list-style-type: none"> 1. Make sure the reconnect switch is configured correctly for the input voltage applied. 2. Primary current limit has been exceeded. Possible short in output circuit. Turn machine off. Remove all loads from the output of the machine. Turn back on. If condition persists, turn power off, and contact an authorized Lincoln Electric Field Service Facility. 3. This problem will normally be accompanied by an error code. Error codes are displayed as a series of red and green flashes by the status LED. 4. If an error code is displayed see Fault Code Explanations. If thermal light is on, wait for machine to cool. 	<ol style="list-style-type: none"> 1. Check the reconnect switch and associated leads for loose or faulty connections. See the wiring diagram. 2. Perform the DC Bus Board Test. 3. Perform the Main Switch Board Test. 4. Perform the Power Board Test. 5. Perform the Output Diode Module Test. 6. The control board may be faulty. 7. The input filter capacitors may be faulty. Check and replace if necessary.
<p>The POWER WAVE® 355/405 will not produce full output.</p>	<ol style="list-style-type: none"> 1. The input voltage may be too low, limiting the output capability of the machine. Make certain the input voltage is correct for the machine and the reconnect switch and jumper lead configuration are correct. 2. The output current or voltage may not be calibrated correctly. Check the values displayed on the Power Feed 10/11 versus readings on an external voltage and ammeter. 3. The welding current may be too high. The machine will fold back to 100 amps if the welding current exceeds 450 amps. 	<ol style="list-style-type: none"> 1. Perform the Input Rectifier Test. 2. Perform the Main Switch Board Test. 3. Perform the Power Board Test. 4. Perform the Current Transducer Test. 5. The control board may be faulty.

 **CAUTION**

If for any reason you do not understand the test procedures or are unable to perform the test/repairs safely, contact the Lincoln Electric Service Department for electrical troubleshooting assistance before you proceed. Call 1-888-935-3877.

POWER WAVE® 355/405



Return to Section TOC

Return to Section TOC

Return to Section TOC

Return to Section TOC

Return to Master TOC

Return to Master TOC

Return to Master TOC

Return to Master TOC

Observe Safety Guidelines detailed in the beginning of this manual.

TROUBLESHOOTING GUIDE

PROBLEMS (SYMPTOMS)	POSSIBLE AREAS OF MISADJUSTMENT(S)	RECOMMENDED COURSE OF ACTION
FUNCTION PROBLEMS		
<p>The machine regularly overheats and the yellow thermal light is ON indicating a thermal overload.</p>	<ol style="list-style-type: none"> 1. The welding application may be exceeding the recommended duty cycle of the POWER WAVE® 355/405. 2. Dirt and dust may have clogged the cooling channels inside the machine. 3. Air intake and exhaust louvers may be blocked due to inadequate clearance around the machine. 4. Make certain the fan as needed (F.A.N.) is operating properly. The fan should operate when welding voltage is present and/or when there is an over temperature condition. 	<ol style="list-style-type: none"> 1. The 115VAC fan motor is controlled by the control board via the main switch board. Perform the Fan Motor And Control Test. 2. A thermostat or associated circuitry may be faulty. See the wiring diagram. One normally closed thermostat is located on the output choke, one on the DC Bus Board and the other is located on the main switch board heat sink. See the wiring diagram. <p>Note: The Main Switch Board Removal Procedure will be required to gain access to the heat sink thermostat.</p>
<p>An attached wire feeder will not function correctly. Apparently the wire feeder is not being powered-up.</p>	<ol style="list-style-type: none"> 1. Make certain the wire feeder control cable is connected to the wire feeder receptacle. See the Wiring Diagram. 2. Check the two circuit breakers located at the front of the machine. Reset if tripped. 3. The wire feeder or control cable may be faulty. 	<ol style="list-style-type: none"> 1. Check for 40 VDC on pin "D" (+) and pin "E" (-) at the Power Wave wire feeder receptacle. See Wiring Diagram. If 40 volts DC is Not present at the Power Wave wire feeder receptacle, perform the DC Bus Board Test. 2. Check the DC Bus Board rectifier. See Wiring Diagram. 3. Perform the T1 Auxiliary transformer Test. 4. If the 40 volts DC is present at the Power Wave wire feeder receptacle, the problem is in the control cable or the wire drive/control box.

 **CAUTION**

If for any reason you do not understand the test procedures or are unable to perform the test/repairs safely, contact the Lincoln Electric Service Department for electrical troubleshooting assistance before you proceed. Call 1-888-935-3877.

POWER WAVE® 355/405



Return to Section TOC

Return to Section TOC

Return to Section TOC

Return to Section TOC

Return to Master TOC

Return to Master TOC

Return to Master TOC

Return to Master TOC

Observe Safety Guidelines detailed in the beginning of this manual.

TROUBLESHOOTING GUIDE

PROBLEMS (SYMPTOMS)	POSSIBLE AREAS OF MISADJUSTMENT(S)	RECOMMENDED COURSE OF ACTION
FUNCTION PROBLEMS		
<p>The machine often “noodle welds” with a particular procedure. The output is limited to approximately 100 amps.</p>	<p>1. The machine may be trying to deliver too much power. When the average output current exceeds a maximum limit, the machine will “phase back” to protect itself. Adjust the procedure or reduce the load to lower the current draw from the Power Wave machine.</p>	<p>1. Perform the <i>Current Transducer Test</i>.</p> <p>2. The control board may be faulty.</p>
<p>Excessively long and erratic arc.</p>	<p>1. Check for proper configuration and implementation of voltage sensing circuits.</p>	<p>1. Check the connections between the voltage sense receptacle and the control board. See the Wiring Diagram.</p> <p>2. The control board may be faulty.</p>

 **CAUTION**

If for any reason you do not understand the test procedures or are unable to perform the test/repairs safely, contact the Lincoln Electric Service Department for electrical troubleshooting assistance before you proceed. Call 1-888-935-3877.

Return to Section TOC
Return to Master TOC

Observe Safety Guidelines detailed in the beginning of this manual.

TROUBLESHOOTING GUIDE

PROBLEMS (SYMPTOMS)	POSSIBLE AREAS OF MISADJUSTMENT(S)	RECOMMENDED COURSE OF ACTION
FUNCTION PROBLEMS		
Auxiliary receptacle is “dead” no auxiliary voltage.	<ol style="list-style-type: none"> 1. Circuit breaker CB1 (on case front) may have opened. Reset. 2. Circuit breaker CB3 (in reconnect area) may have opened. Reset. 3. On PW 405 models, the circuit breaker CB4 protects the 220VAC receptacle. Reset if tripped. 	<ol style="list-style-type: none"> 1. Perform the Auxiliary Transformer Test.
A fault or error code is displayed.	<ol style="list-style-type: none"> 1. See Fault Code Explanations. 	<ol style="list-style-type: none"> 1. See Fault Code Explanations.
General degradation of the weld performance.	<ol style="list-style-type: none"> 1. Check for feeding problems, bad connections, excessive loops in cabling, etc. 2. Verify weld mode is correct for processes. 3. The power source may require calibration. 4. Check the actual current displayed on the Power Feed 10 vs. actual current measured via external meter. 5. Check the actual voltage displayed on the Power Feed 10 vs. actual voltage measured via external meter. 6. Check the actual WFS displayed on the Power Feed 10 vs. actual WFS measured via external meter. 	<ol style="list-style-type: none"> 1. Perform the Voltage and Current Calibration Procedure in Power Wave Manager.. 2. Perform the Current Transducer Test. 2. Perform the Output Diode Module Test. 5. The control board may be faulty.

 **CAUTION**

If for any reason you do not understand the test procedures or are unable to perform the test/repairs safely, contact the Lincoln Electric Service Department for electrical troubleshooting assistance before you proceed. Call 1-888-935-3877.

Return to Section TOC | Return to Section TOC | Return to Section TOC | Return to Section TOC | Return to Section TOC | Return to Section TOC

TROUBLESHOOTING & REPAIR

USING THE STATUS LED TO TROUBLESHOOT SYSTEM PROBLEMS

The Power Wave / Power Feed are best diagnosed as a system. Each component (power source, user interface, and feed head) has a status light, and when a problem occurs it is important to note the condition of each. In addition, errors displayed on the user interface in most cases indicate only that a problem exists in the power source, not what the problem may be. **Therefore, prior to cycling power to the system, check the power source status light for error sequences as noted below. This is especially important if the user interface displays “Err 006” or “Err 100”.**

Included in this section is information about the power source Status LED, and some basic troubleshooting charts for both machine and weld performance.

The STATUS LIGHT is a two color light that indicates system errors. Normal operation is a steady green light. Error conditions are indicated in the following chart.

NOTE: The POWER WAVE® 355/405 status light will flash green, and sometimes red and green, for up to one minute when the machine is first turned on. This is a normal situation as the machine goes through a self test at power up.

LIGHT CONDITION	INDICATION
Status LED is solid green (no blinking)	1. System OK. Power source communicating normally with wire feeder and its components.
Status LED is blinking green	2. Occurs during a reset, and indicates the POWER WAVE® 355/405 is mapping (identifying) each component in the system. Normal for first 1-10 seconds after power is turned on, or if the system configuration is changed during operation.
Status LED is blinking red and green	3. Non-recoverable system fault. If the PS Status light is flashing any combination of red and green, errors are present in the POWER WAVE® 355/405. Read the error code before the machine is turned off. Error Code interpretation through the Status light is detailed in the Service Manual. Individual code digits are flashed in red with a long pause between digits. The codes will be separated by a green light. There may be more than one error code indicated. To clear the error, turn power source off, and back on to reset.
Status LED is solid red (no blinking).	Non-recoverable hardware fault. Generally indicates nothing is connected to the POWER WAVE® 355/405 wire feeder receptacle. See Trouble Shooting Section.
Status LED is blinking red.	Not applicable

POWER WAVE® 355/405



Return to Section TOC
Return to Master TOC
Return to Section TOC
Return to Master TOC
Return to Section TOC
Return to Master TOC
Return to Section TOC
Return to Master TOC

STATUS LED ERROR CODE TABLE

NOTE: The error code signal sequence is always preceded by a 2 second green light. If more than one error code is present, a 4 second off signal will separate the individual error code signals. Note that the [2 sec. green] is only displayed at the beginning of the entire code sequence, not between codes if more than one error code is present.

Example: (Code. #11 “one long red” followed by “one short red”) followed by (Code. #21 “two long reds” followed by “one short red”).

[2 sec. green] [1.2 sec. red] [1.6 sec. off] [0.4 sec. red] [4.0 sec. off] [1.2 sec. red] [0.4 sec. off]
[1.2 sec. red] [1.6 sec. off] [0.4 sec. red]

ERROR CODES FOR THE POWER WAVE®

The following is a list of possible error codes that the POWER WAVE® 355/405 can output via the status light (see “Troubleshooting the Power Wave / Power Feed System using the Status LED.” If connected to a PF-10/11 these error codes will generally be accompanied by an “Err 006” or “Err 100” on the user interface display.

11	CAN communication bus off.	Probably due to excessive number of communication errors.
12	User interface time out error.	UI is no longer responding to the Power Source. The most likely cause is a fault/bad connection in the communication leads or control cable.
21	Unprogrammed weld mode.	Contact the service department for instructions on reloading the Welding Software.
22	Empty weld table.	Contact the service department for instructions on reloading the Welding Software.
23	Weld table checksum error.	Contact the service department for instructions on reloading the Welding Software.
31	Primary overcurrent error.	Excessive Primary current present. May be related to a short in the main transformer or output rectifier.
32	Capacitor “A” under voltage.	Low voltage on the main capacitors. May be caused by improper input configuration.
33	Capacitor “B” under voltage.	When accompanied by an overvoltage error on the same side, it indicates no capacitor voltage present on that side, and is usually the result of an open or short in the primary side of the machine.
34	Capacitor “A” overvoltage.	Excessive voltage on the main capacitors. May be caused by improper input configuration.
35	Capacitor “B” overvoltage.	When accompanied by an under voltage error on the same side, it indicates no capacitor voltage present on that side, and is usually the result of an open or short in the primary side of the machine.
36	Thermal error.	Indicates over temperature. Usually accompanied by thermal LED. Check fan operation. Be sure process does not exceed duty cycle limit of the machine.
37	Softstart error.	Capacitor precharge failed. Usually accompanied by codes 32-35.
41	Secondary overcurrent error	The secondary (weld) current limit has been exceeded. When this occurs the machine output will phase back to 100 amps, typically resulting in a condition referred to as “noodle welding” NOTE: The secondary limit is 570 for the standard stud, and 325 amps for all single phase operation.

POWER WAVE® 355/405



TROUBLESHOOTING & REPAIR

43	Capacitor delta error.	The maximum voltage difference between the main capacitors has been exceeded. May be accompanied by errors 32-35. Check the output diodes.
	Other	Error codes that contain three or four digits are defined as fatal errors. These codes generally indicate internal errors on the Control Board. If cycling the input power on the machine does not clear the error, try reloading the operating system. If this fails, replace the Control Board.

Return to Section TOC
Return to Master TOC

NOTES

Return to Section TOC
Return to Master TOC

Return to Section TOC
Return to Master TOC

Return to Section TOC
Return to Master TOC

Return to Section TOC
Return to Master TOC

POWER WAVE® 355/405



TROUBLESHOOTING & REPAIR

INPUT FILTER CAPACITOR DISCHARGE PROCEDURE



WARNING

Service and repair should be performed by only Lincoln Electric factory trained personnel. Unauthorized repairs performed on this equipment may result in danger to the technician or machine operator and will invalidate your factory warranty. For your safety and to avoid electrical shock, please observe all safety notes and precautions detailed throughout this manual.

If for any reason you do not understand the test procedures or are unable to perform the test/repairs safely, contact the Lincoln Electric Service Department for electrical troubleshooting assistance before you proceed. Call 1-888-935-3877.

DESCRIPTION

This procedure will drain off any charge stored in the four large capacitors that are part of the switch board assembly. This procedure **MUST** be performed, as a safety precaution, before conducting any test or repair procedure that requires you to touch internal components of the machine.

MATERIALS NEEDED

- 5/16" Nut Driver
- Insulated Pliers
- Insulated Gloves
- High Wattage Resistor (25-1000 ohms and 25 watts minimum)
- DC Volt Meter

TROUBLESHOOTING & REPAIR

INPUT FILTER CAPACITOR DISCHARGE PROCEDURE *(continued)*

⚠ WARNING

ELECTRIC SHOCK can kill.



- Have an electrician install and service this equipment.
- Turn the input power off at the fuse box before working on equipment.
- Do not touch electrically hot parts.
- Prior to performing preventative maintenance, perform the following capacitor discharge procedure to avoid electric shock.

DISCHARGE PROCEDURE

1. Remove the input power to the POWER WAVE® 355/405.
2. Using the 5/16" wrench remove the screws from the case wraparound cover.
3. Be careful not to make contact with the capacitor terminals located at the top and bottom of the switch board.

4. Obtain a high resistance and high wattage resistor (25-1000 ohms and 25 watts minimum). This resistor is not with the machine. NEVER USE A SHORTING STRAP FOR THIS PROCEDURE.
5. Locate the eight capacitor terminals shown in figure F.1.
6. Using electrically insulated gloves and pliers, hold the body of the resistor with the pliers and connect the resistor leads across the two capacitor terminals. Hold the resistor in place for 10 seconds. DO NOT TOUCH CAPACITOR TERMINALS WITH YOUR BARE HANDS.
7. Repeat the discharge procedure for the other three capacitors.
8. Check the voltage across the terminals of all capacitors with a DC voltmeter. Polarity of the capacitor terminals is marked on the PC board above the terminals. Voltage should be zero. If any voltage remains, repeat this capacitor discharge procedure.

FIGURE F.1 – LOCATION OF INPUT FILTER CAPACITOR TERMINALS

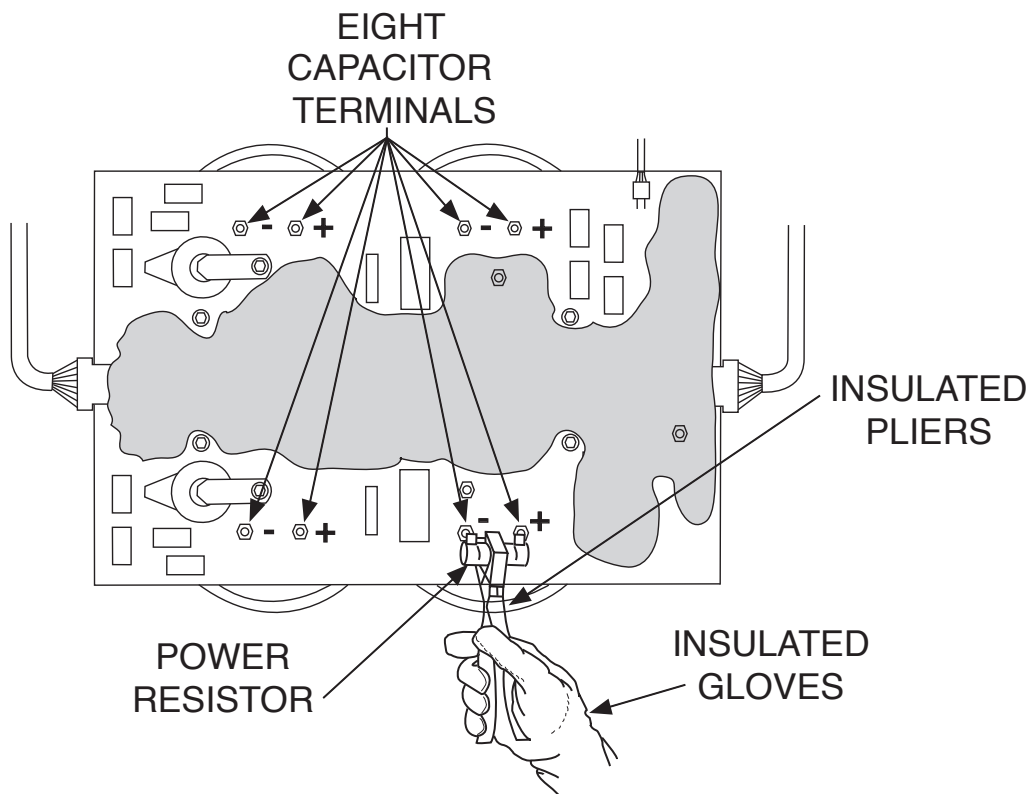

POWER WAVE® 355/405

LINCOLN
ELECTRIC

TROUBLESHOOTING & REPAIR

MAIN SWITCH BOARD TEST



WARNING

Service and repair should be performed by only Lincoln Electric factory trained personnel. Unauthorized repairs performed on this equipment may result in danger to the technician or machine operator and will invalidate your factory warranty. For your safety and to avoid electrical shock, please observe all safety notes and precautions detailed throughout this manual. If for any reason you do not understand the test procedures or are unable to perform the test/repairs safely, contact the Lincoln Electric Service Department for electrical troubleshooting assistance before you proceed. Call 1-888-935-3877.

DESCRIPTION

This test will help determine if the “power section” of the switch boards are functioning correctly. This test will NOT indicate if the entire PC board is functional. This resistance test is preferable to a voltage test with the machine energized because this board can be damaged easily. In addition, it is dangerous to work on this board with the machine energized.

MATERIALS NEEDED

- Analog Volt/Ohmmeter
- 5/16 in. Wrench
- 7/16 in. Wrench

TROUBLESHOOTING & REPAIR

MAIN SWITCH BOARD TEST (continued)

FIGURE F.2 MAIN SWITCH BOARD LEAD LOCATIONS

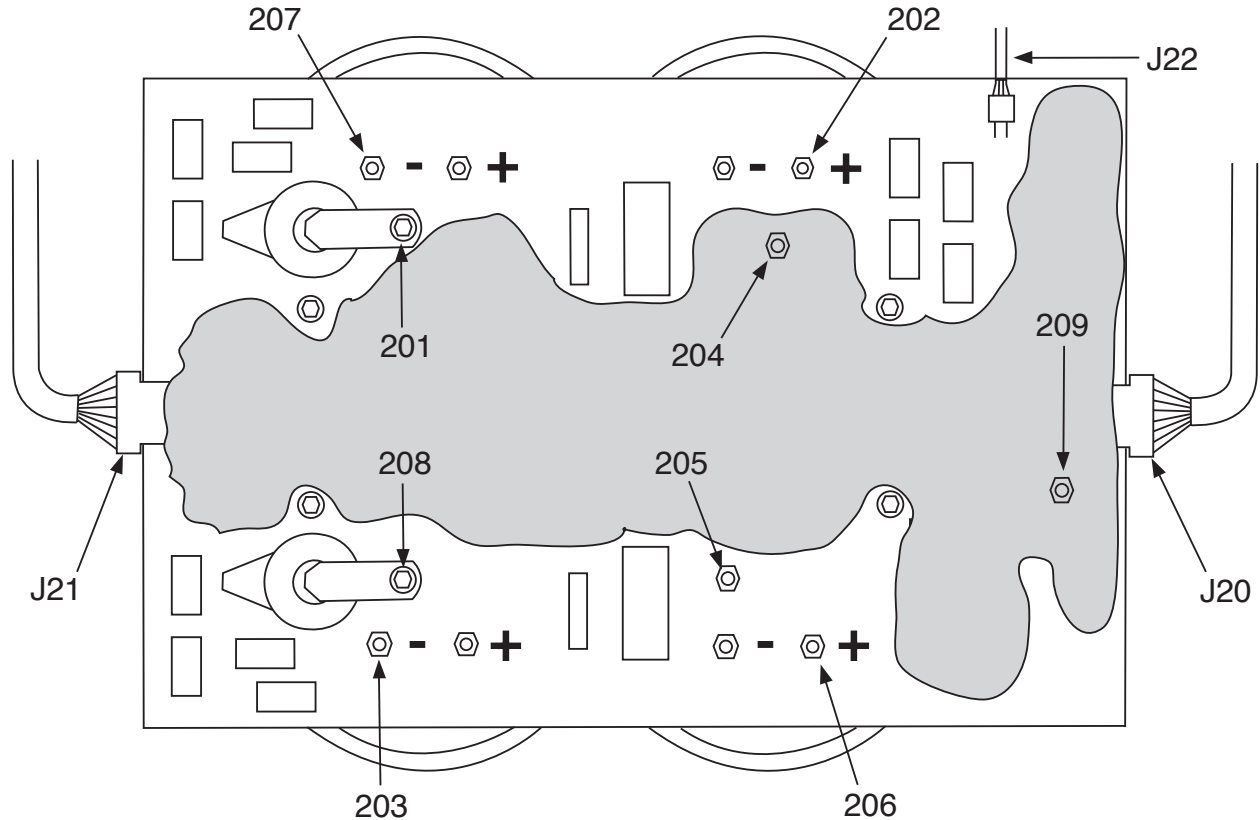

TEST PROCEDURE

1. Remove input power to the POWER WAVE® 355/405.
2. Using a 5/16" nut driver, remove the case wraparound.
3. Perform the **Input Filter Capacitor Discharge Procedure** detailed earlier in this section.
4. Using a 7/16" wrench locate, label and remove leads 201, 202, 203, 204, 205, 206, 207 and 208 from the switch board. Note lead and washer placement for reassembly. Clear leads.
5. Using the Analog ohmmeter, perform the resistance tests detailed in **Table F.1**. Refer to figure F.2 for test point locations. Note: Test using an Analog ohmmeter on the Rx1 range. Make sure the test probes are making electrical contact with the conductor surfaces on the PC board.

POWER WAVE® 355/405



TROUBLESHOOTING & REPAIR

MAIN SWITCH BOARD TEST *(continued)*

6. If any test fails replace the switch board. See **Main Switch Board Removal and Replacement**.
7. If the switch board resistance tests are OK, check connections on plugs J20, J21, J22 and all associated wiring. See wiring diagram.
8. Reconnect leads 201, 202, 203, 204, 205, 206, 207, and 208 to the switch board. Ensure that the leads are installed in their proper locations. Pre-Torque all leads nuts to 25 inch lbs. before tightening them to 44 inch lbs.
9. Replace the case wraparound cover using a 5/16" nut driver.

TABLE F.1. SWITCH BOARD RESISTANCE TEST

APPLY POSITIVE TEST PROBE TO TERMINAL	APPLY NEGATIVE TEST PROBE TO TERMINAL	NORMAL RESISTANCE READING
+206	-205	Greater than 1000 ohms
+208	-203	Greater than 1000 ohms
+202	-204	Greater than 1000 ohms
+201	-207	Greater than 1000 ohms
+205	-206	Less than 100 ohms
+203	-208	Less than 100 ohms
+204	-202	Less than 100 ohms
+207	-201	Less than 100 ohms

Return to Section TOC
Return to Master TOC

INSTALLATION

MAIN SWITCH BOARD TEST (continued)

FIGURE F.3 – PLUG J21 LEADS AND LOCATION

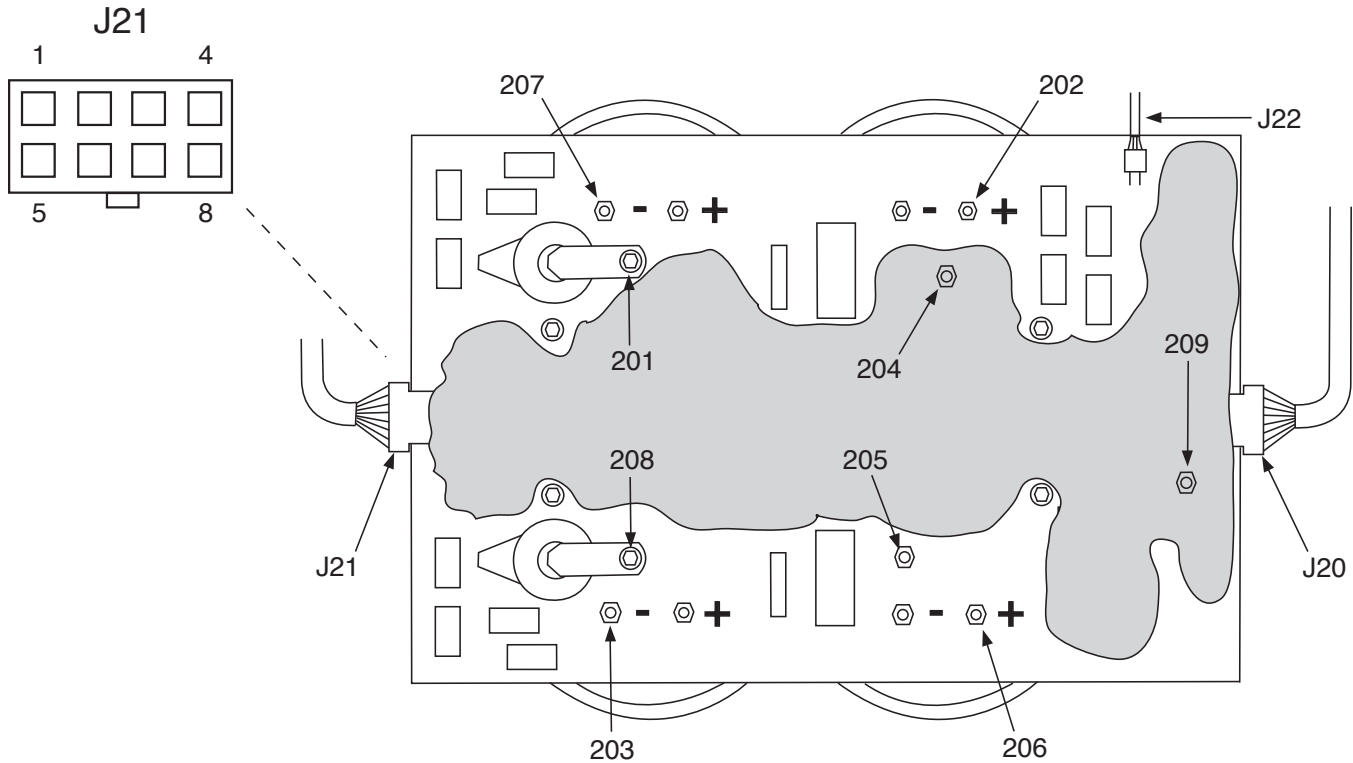

PRIMARY CURRENT TRANSDUCER(S) TEST

Current Transducers (CT) Test Description

The two primary current transducers (CT2 and CT3) monitor the primary currents in the primary windings of the main transformer. See the wiring diagram. The output of the CTs is sent to the control board for processing. If the primary current feedback signals (output of the CTs) are not balanced the control board will adjust the pulse width modulation (PWM) signal sent to the switch board to keep the IGBTs balanced. Also, if either side of the switch board is supplying too much current to the main transformer the control board will remove the PWM signal and the inverter will be shut off to protect the switch board.

The best way to test a current transducer is by measuring the inductance. The CTs are housed on the IGBT switch board. The measurements should always be made without removing the IGBT switch board from the machine.

MATERIALS NEEDED

- Volt-Ohmmeter with inductance measuring capabilities (Amprobe Model 37XR-A)
- Wiring Diagram

INSTALLATION

MAIN SWITCH BOARD TEST *(continued)*

TEST PROCEDURE

1. Remove the input power to the PW355/405 machine.
2. Perform the ***Input Filter Capacitor Discharge Procedure***.
3. Locate and remove plug J21 from the IGBT Switch Board. See ***Figure F.3***.
4. Using the Volt-Ohmmeter with inductance measuring capabilities check the CT3 current transducer inductance by checking from J21 pin 1 (#1001) to J21 pin 5 (#1002). Normal inductance is approximately 50mH. +/- 20%. See ***Figure F.3***. These measurements must be made at the plug J21 receptacle on the PC board.
5. Using the Volt-Ohmmeter with inductance measuring capabilities check the CT2 current transducer inductance by checking from J21 pin 4 (#1010) to J21 pin 8 (#1020). Normal inductance is approximately 50mH. +/- 20%. See ***Figure F.3***. These measurements must be made at the plug J21 receptacle on the PC board.
6. If the inductance reading is not correct replace the IGBT switch board.
7. When testing is complete replace plug J21 into the correct receptacle. See ***Figure F.3***.
8. Replace the covers.

NOTES

Return to Section TOC
Return to Master TOC

Return to Section TOC
Return to Master TOC

Return to Section TOC
Return to Master TOC

Return to Section TOC
Return to Master TOC

TROUBLESHOOTING & REPAIR

INPUT RECTIFIER TEST



WARNING

Service and repair should be performed by only Lincoln Electric factory trained personnel. Unauthorized repairs performed on this equipment may result in danger to the technician or machine operator and will invalidate your factory warranty. For your safety and to avoid electrical shock, please observe all safety notes and precautions detailed throughout this manual.

If for any reason you do not understand the test procedures or are unable to perform the test/repairs safely, contact the Lincoln Electric Service Department for electrical troubleshooting assistance before you proceed. Call 1-888-935-3877.

DESCRIPTION

This test will help determine if the input rectifier has “shorted” or “open” diodes.

MATERIALS NEEDED

- Analog Voltmeter/Ohmmeter (Multimeter)
- 5/16” Nut Driver
- Phillips Head Screwdriver
- Wiring Diagram

TROUBLESHOOTING & REPAIR

INPUT RECTIFIER TEST (CONTINUED)

TEST PROCEDURE

1. Remove input power to the POWER WAVE® 355/405 machine.
2. Using a 5/16" nut driver, remove the case wraparound cover.
3. Perform the **Capacitor Discharge Procedure** detailed earlier in this section.
4. Locate the input rectifier and associated leads. See Figure F.4.
5. Carefully remove the silicone sealant from leads 207, 207A, and 209.
6. Using a phillips head screwdriver, remove leads 207, 207A, and 209 from the input rectifier.
7. Use the analog ohmmeter to perform the tests detailed in **Table F.2**. See the Wiring Diagram.
8. Visually inspect the three MOV'S for damage (TP1,TP2,TP3). Replace if necessary.

Figure F.4 Input Rectifier

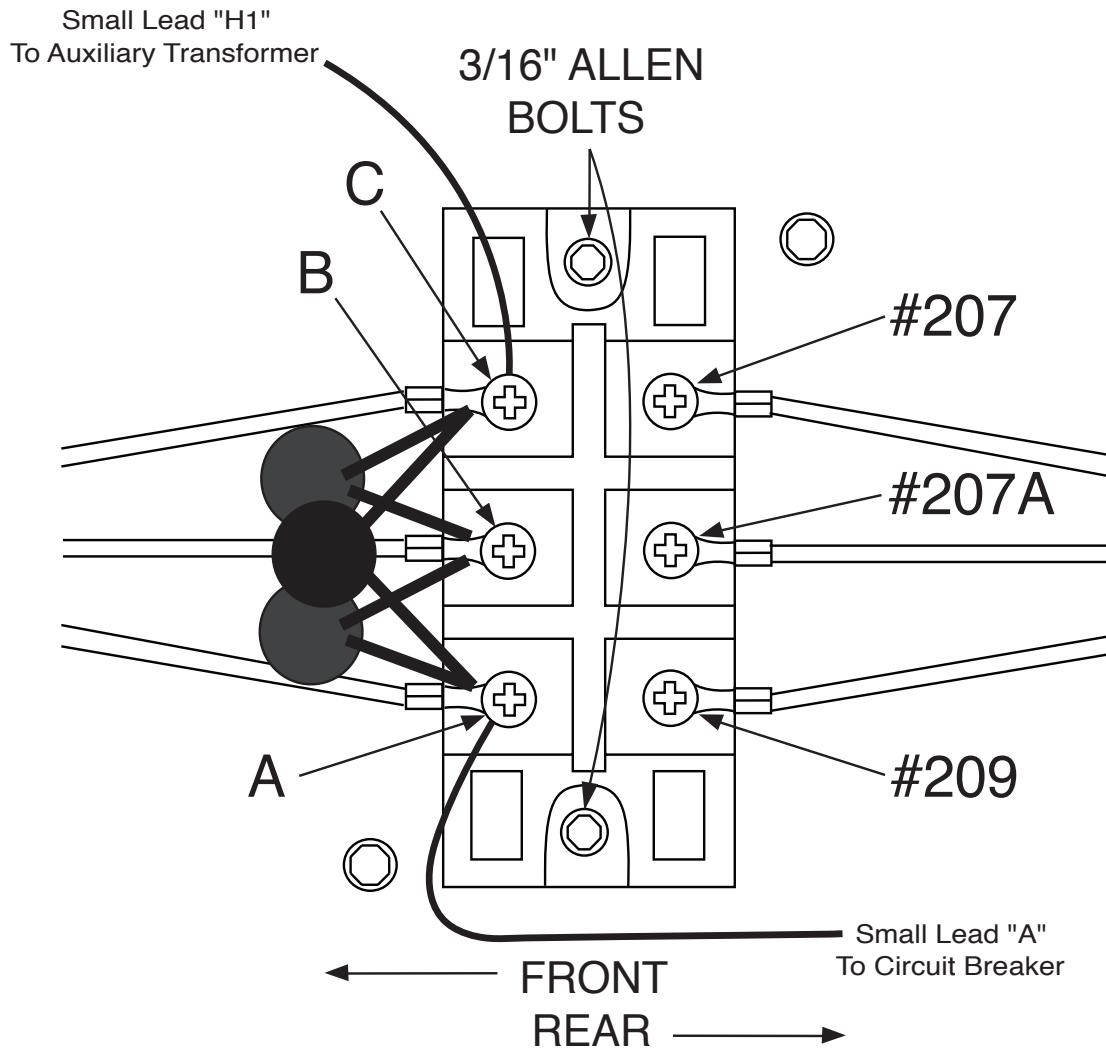

POWER WAVE® 355/405

LINCOLN
ELECTRIC

TROUBLESHOOTING & REPAIR

INPUT RECTIFIER TEST (CONTINUED)

Table F.2 Input Rectifier Test Points

TEST POINT TERMINALS		ANALOG METER X10 RANGE
+ PROBE	- PROBE	Acceptable Meter Readings
A	207	Greater than 1000 ohms
B	207	Greater than 1000 ohms
C	207	Greater than 1000 ohms
A	207A	Greater than 1000 ohms
B	207A	Greater than 1000 ohms
C	207A	Greater than 1000 ohms
A	209	Less than 100 ohms
B	209	Less than 100 ohms
C	209	Less than 100 ohms
207	A	Less than 100 ohms
207	B	Less than 100 ohms
207	C	Less than 100 ohms
207A	A	Less than 100 ohms
207A	B	Less than 100 ohms
207A	C	Less than 100 ohms
209	A	Greater than 1000 ohms
209	B	Greater than 1000 ohms
209	C	Greater than 1000 ohms

9. If the input rectifier does not meet the acceptable readings outlined in Table F.2 the component may be faulty. Replace.

Note: Before replacing the input rectifier, check the input power switch and perform the **Main Switch Board Test**. Also check for leaky or faulty filter capacitors.
10. If the input rectifier is good, be sure to reconnect leads 207, 207A, and 209 to the correct terminals and torque to 31 inch lbs. Apply silicone sealant.
11. If the input rectifier is faulty, see the **Input Rectifier Bridge Removal & Replacement** procedure.
12. Replace the case wraparound cover.

NOTES

Return to Section TOC
Return to Master TOC

Return to Section TOC
Return to Master TOC

Return to Section TOC
Return to Master TOC

Return to Section TOC
Return to Master TOC

POWER WAVE® 355/405



TROUBLESHOOTING & REPAIR

POWER BOARD TEST



WARNING

Service and repair should be performed by only Lincoln Electric factory trained personnel. Unauthorized repairs performed on this equipment may result in danger to the technician or machine operator and will invalidate your factory warranty. For your safety and to avoid electrical shock, please observe all safety notes and precautions detailed throughout this manual.

If for any reason you do not understand the test procedures or are unable to perform the test/repairs safely, contact the Lincoln Electric Service Department for electrical troubleshooting assistance before you proceed. Call 1-888-935-3877.

DESCRIPTION

This test will help determine if the power board is receiving the correct voltages and also if the power board is regulating and producing the correct DC voltages.

MATERIALS NEEDED

- Volt-Ohmmeter
- 3/8" Nut Driver
- Wiring Diagram

TROUBLESHOOTING & REPAIR

POWER BOARD TEST (CONTINUED)

FIGURE F.5 – POWER BOARD TEST

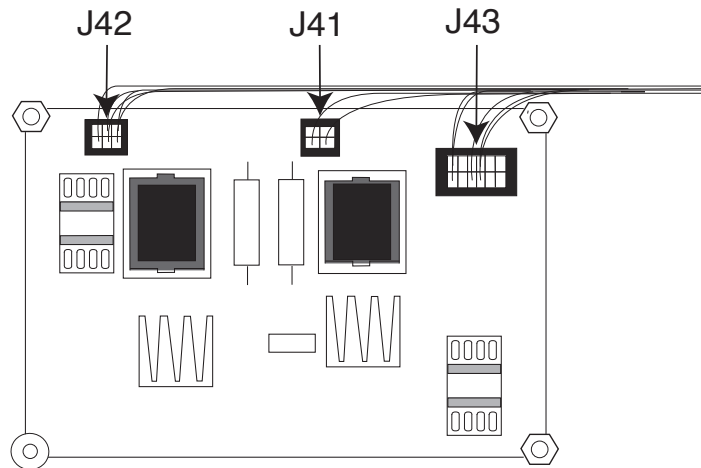
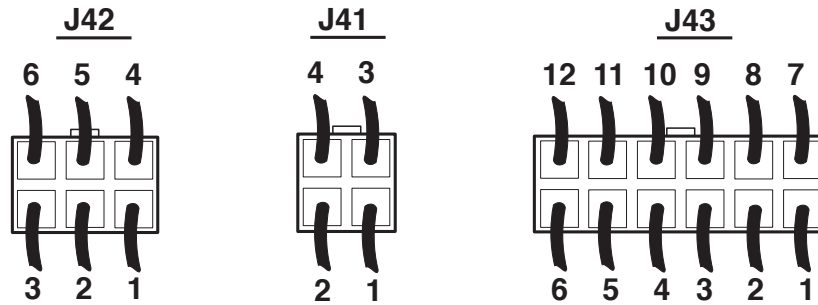

TEST PROCEDURE

1. Remove input power to the Power Wave® 355/405.
2. Using the 3/8" nut driver, remove the case top.
3. Perform the **Capacitor Discharge Procedure**.
4. Locate the Power Board and plugs J42 and J43. **Do not remove plugs or leads from the Power Board.** Refer to Figure F.9.
5. Carefully apply input power to the Power Wave® 355/405.
6. Turn on the Power Wave® 355/405. Carefully test for the correct voltages at the Power Board according to **Table F.4**.
7. If either of the 40 VDC voltages is low or not present at plug J41, perform the **DC Bus PC Board Test**. See the Wiring Diagram. Also perform the **T1 Auxiliary Transformer Test**.
8. If any of the DC voltages are low or not present at plugs J42 and/or 43, the Power Board may be faulty.
9. Install the case top using the 3/8" nut driver.



WARNING



ELECTRIC SHOCK can kill.

High voltage is present when input power is applied to the machine.

POWER WAVE® 355/405

LINCOLN
ELECTRIC

TROUBLESHOOTING & REPAIR

POWER BOARD TEST (CONTINUED)

TABLE F.3 – POWER BOARD VOLTAGE CHECKS

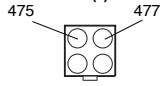
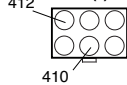
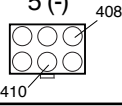
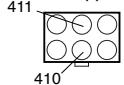
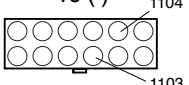
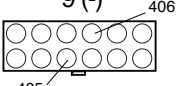
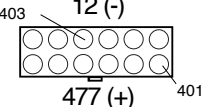
CHECK POINT LOCATION	TEST DESCRIPTION	CONNECTOR PLUG PIN NO.	LEAD NO. OR IDENTITY	NORMAL ACCEPTABLE VOLTAGE READING
POWER BOARD CONNECTOR PLUG J41	CHECK 40 VDC INPUT FROM DC BUS BOARD	2 (+) 1 (-) 	475 (-)	38 – 42 VDC
POWER BOARD CONNECTOR PLUG J42	CHECK +15 VDC SUPPLY FROM POWER BOARD	1 (+) 5 (-) 	412 (+) 410 (-)	+15 VDC
POWER BOARD CONNECTOR PLUG J42	CHECK +5 VDC SUPPLY FROM POWER BOARD	3 (+) 5 (-) 	408 (+) 410 (-)	+5 VDC
POWER BOARD CONNECTOR PLUG J42	CHECK -15 VDC SUPPLY FROM POWER BOARD	2 (+) 5 (-) 	411 (+) 410 (-)	-15 VDC
POWER BOARD CONNECTOR PLUG J43	CHECK +5 VDC ARCLINK SUPPLY FROM POWER BOARD	5 (+) 10 (-) 	1104 (+) 1103 (-)	+5 VDC
POWER BOARD CONNECTOR PLUG J43	CHECK +5 VDC "RS-232" SUPPLY FROM POWER BOARD	4 (+) 9 (-) 	406 (+) 405 (-)	+5 VDC
POWER BOARD CONNECTOR PLUG J43	CHECK +5 VDC SPI SUPPLY FROM POWER BOARD	3 (+) 12 (-) 	403 (+) 401 (-)	+5 VDC

Return to Section TOC
Return to Master TOC

NOTES

Return to Section TOC
Return to Master TOC

Return to Section TOC
Return to Master TOC

Return to Section TOC
Return to Master TOC

Return to Section TOC
Return to Master TOC

POWER WAVE® 355/405



DC BUS BOARD TEST



WARNING

Service and repair should be performed by only Lincoln Electric factory trained personnel. Unauthorized repairs performed on this equipment may result in danger to the technician or machine operator and will invalidate your factory warranty. For your safety and to avoid electrical shock, please observe all safety notes and precautions detailed throughout this manual.

If for any reason you do not understand the test procedures or are unable to perform the test/repairs safely, contact the Lincoln Electric Service Department for electrical troubleshooting assistance before you proceed. Call 1-888-935-3877.

TEST DESCRIPTION

This test will determine if the DC Bus Power Supply PC Board is receiving and processing the proper voltages.

MATERIALS NEEDED

- 3/8" Nut driver
- Volt/ohmmeter
- Wiring Diagram

TROUBLESHOOTING & REPAIR

DC BUS BOARD TEST (CONTINUED)

6. Check the DC Bus Board input and output voltages according to Table F.4. See **Figure F.7** and the Wiring Diagram.

7. If all the voltages are correct, the DC Bus Board is operating properly.

8. If any of the output voltages are not correct and the input voltage is correct, the DC Bus Board may be faulty.

9. If the input voltage is not correct, check the leads between the DC Bus Board and the Bus Rectifier. See the Wiring Diagram.

10. When finished testing, replace the case wraparound cover.

WARNING



ELECTRIC SHOCK can kill.

High voltage is present at the terminals of Capacitor C3 near where testing is to be done.

TABLE F.4 – DC BUS POWER SUPPLY PC BOARD VOLTAGE TABLE

Positive Meter Probe Test Point	Negative Meter Probe Test Point	Approximate Voltage Reading	Conditions/Comments
Plug P46 – Pin 1 Lead 65	Plug P46 – Pin 3 Lead 66	65 – 75 VDC	Should be same as the Bus Rectifier
Plug P47 – Pin 8(+) Lead 52	Plug P47 – Pin 1(-) Lead 51	38.0 – 42.0 VDC	Supply to the Wire Feeder Receptacle
Plug P47 – Pin 3(+) Lead 477	Plug P47 – Pin 6(-) Lead 475	38.0 – 42.0 VDC	Supply to Power Board

Return to Section TOC
 Return to Master TOC
 Return to Section TOC
 Return to Master TOC
 Return to Section TOC
 Return to Master TOC
 Return to Section TOC
 Return to Master TOC

NOTES

Return to Section TOC
Return to Master TOC

Return to Section TOC
Return to Master TOC

Return to Section TOC
Return to Master TOC

Return to Section TOC
Return to Master TOC

POWER WAVE® 355/405



TROUBLESHOOTING & REPAIR

OUTPUT DIODE MODULES TEST



WARNING

Service and repair should be performed by only Lincoln Electric factory trained personnel. Unauthorized repairs performed on this equipment may result in danger to the technician or machine operator and will invalidate your factory warranty. For your safety and to avoid electrical shock, please observe all safety notes and precautions detailed throughout this manual.

If for any reason you do not understand the test procedures or are unable to perform the test/repairs safely, contact the Lincoln Electric Service Department for electrical troubleshooting assistance before you proceed. Call 1-888-935-3877.

DESCRIPTION

This test will help determine if any of the output diodes are “shorted”.

MATERIALS NEEDED

Analog Voltmeter/Ohmmeter
Wiring Diagram

TROUBLESHOOTING & REPAIR

OUTPUT DIODE MODULES TEST *(continued)*

FIGURE F.8 Machine Output Terminals

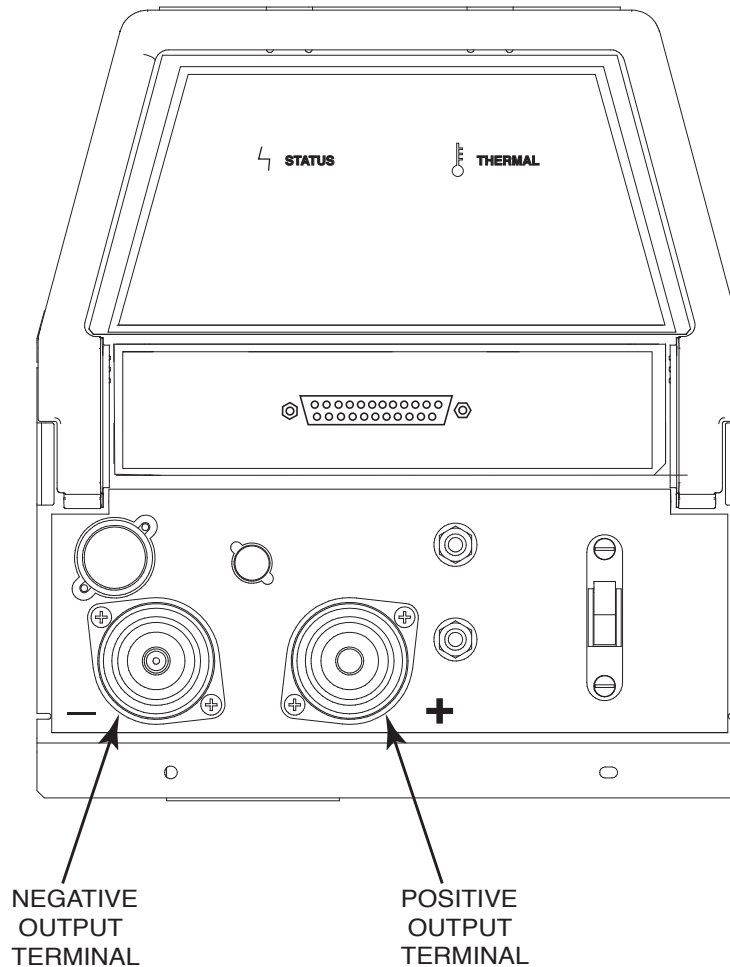

TEST PROCEDURE

1. Remove input power to the POWER WAVE® 355/405.
2. Locate the output terminals on the front panel of the machine. See Figure F.8.
3. Remove any output cables and load from the output terminals.
4. Using the analog ohmmeter test for more than 200 ohms resistance between positive and negative output terminals. Positive test lead to the positive terminal; Negative test lead to the negative terminal. **See Figure F.9.**

NOTE: The polarity of the test leads is most important. If the test leads polarity is not correct, the test will have erroneous results.

POWER WAVE® 355/405



Return to Section TOC

Return to Section TOC

Return to Section TOC

Return to Section TOC

Return to Master TOC

Return to Master TOC

Return to Master TOC

Return to Master TOC

TROUBLESHOOTING & REPAIR

OUTPUT DIODE MODULES TEST (continued)

Figure F.9 Terminal Probes

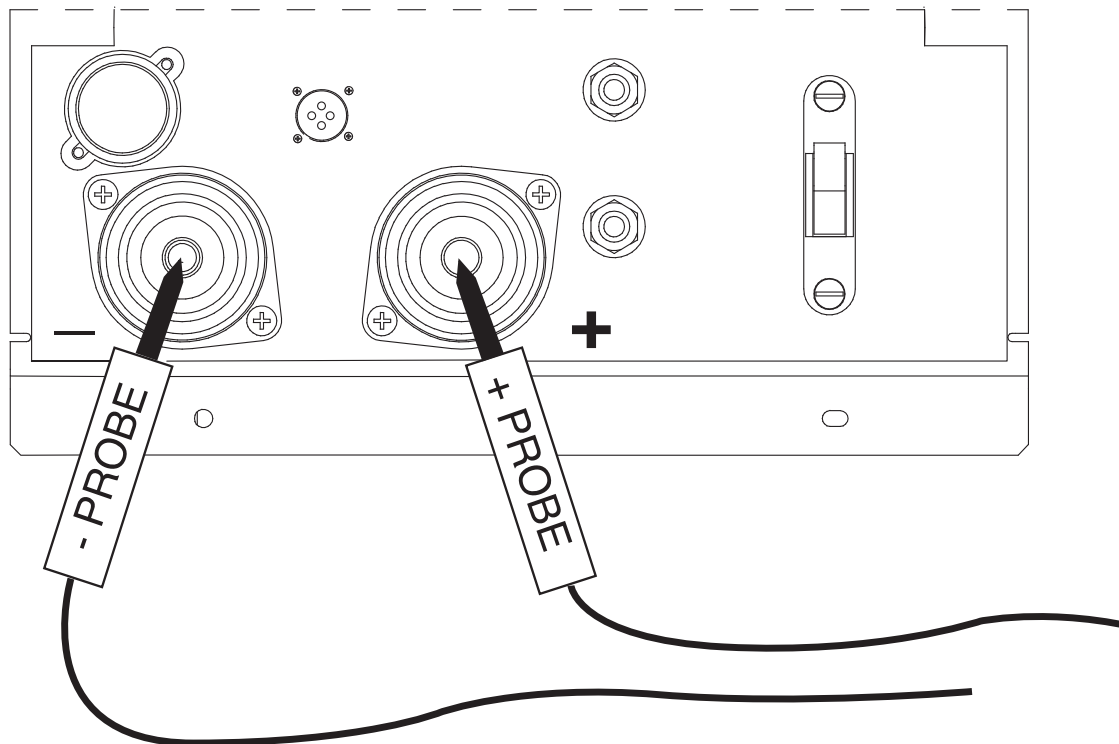

5. If 200 ohms is measured then the output diodes are not "shorted".
9. Test all output diode modules individually.

NOTE: There is a 250 ohm resistor across the welding output terminals. *See Wiring Diagram*

NOTE: This may require the disassembly of the leads and the snubber board from the diode modules. Refer to the *Output Diode Modules Removal and Replacement Procedure* for detailed instructions.

6. If less than 200 ohms is measured, one or more diodes or the snubber board may be faulty.
7. Perform the *Filter Capacitor Discharge Procedure* detailed in the maintenance section.
8. Locate the output diode modules and snubber board. *See Figure F.10.*

TROUBLESHOOTING & REPAIR

OUTPUT DIODE MODULES TEST *(continued)*

Figure F.10 Snubber and Output Diode Locations

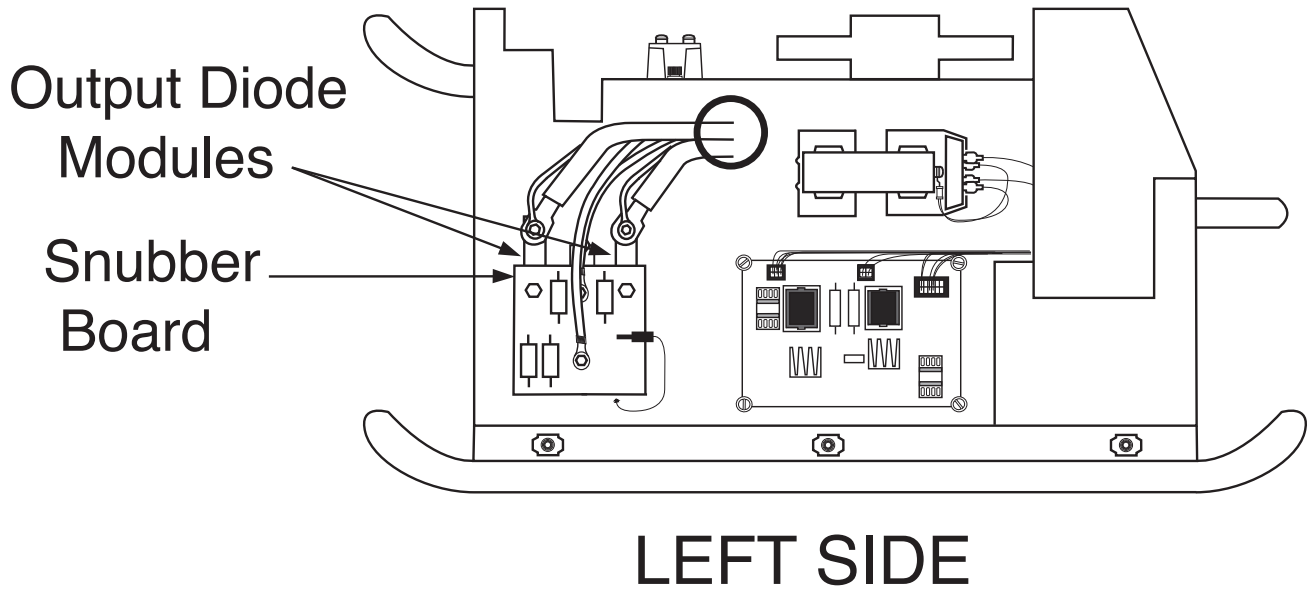

Return to Section TOC

Return to Master TOC

Return to Section TOC

Return to Master TOC

Return to Section TOC

Return to Master TOC

Return to Section TOC

Return to Master TOC

TROUBLESHOOTING & REPAIR

AUXILIARY TRANSFORMER TEST



WARNING

Service and repair should be performed by only Lincoln Electric factory trained personnel. Unauthorized repairs performed on this equipment may result in danger to the technician or machine operator and will invalidate your factory warranty. For your safety and to avoid electrical shock, please observe all safety notes and precautions detailed throughout this manual.

If for any reason you do not understand the test procedures or are unable to perform the test/repairs safely, contact the Lincoln Electric Service Department for electrical troubleshooting assistance before you proceed. Call 1-888-935-3877.

DESCRIPTION

This procedure will determine if the correct voltage is being applied to the primary of auxiliary transformer and also if the correct voltage is being induced on the secondary windings of the transformer.

MATERIALS NEEDED

- Volt-ohmmeter (Multimeter)
- 5/16" Nut Driver
- Wiring Diagram

TROUBLESHOOTING & REPAIR

AUXILIARY TRANSFORMER TEST *(continued)*

FIGURE F.11 Auxiliary Transformer

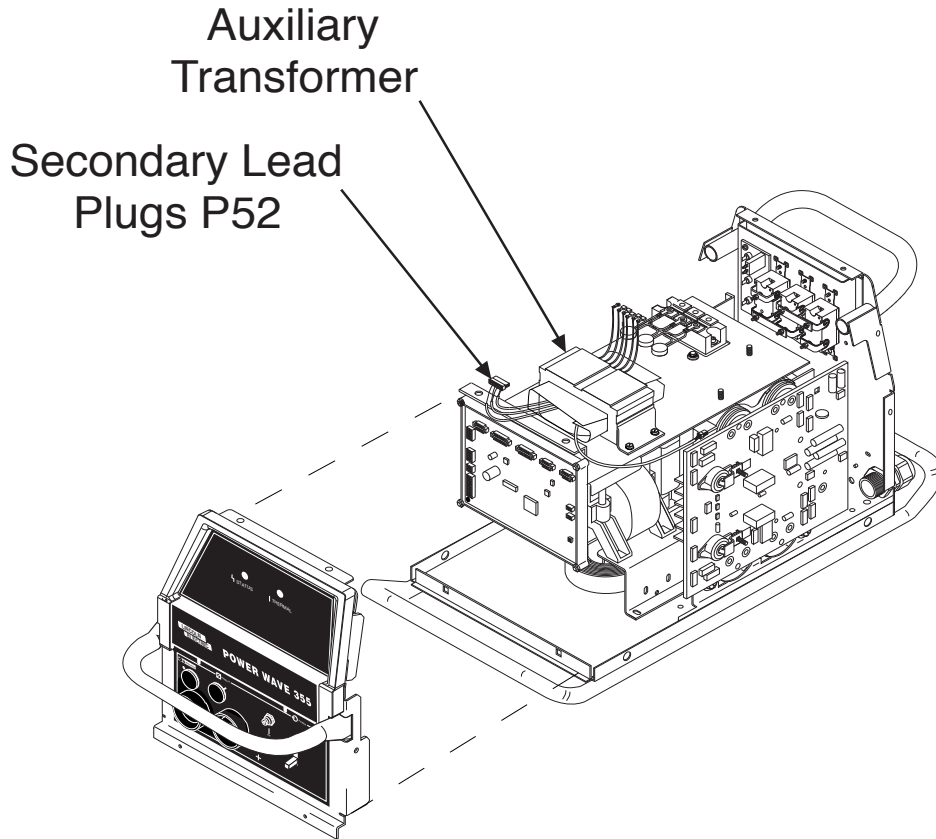

TEST PROCEDURE

1. Remove input power to the POWER WAVE® 355/405.
2. Using a 5/16" nut driver, remove the case wraparound cover.
3. Perform the ***Input Capacitor Discharge Procedure*** detailed earlier in this section.
4. Locate the auxiliary transformer. See Figure F.11.
5. Locate the secondary leads and plug P52. See Figure F.11 and F.12.

FIGURE F.12 Plug Lead Connections Viewed From Transformer Lead Side of Plug

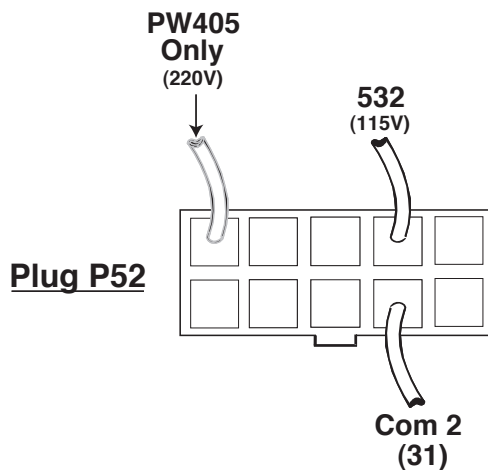

POWER WAVE® 355/405



Return to Section TOC
 Return to Section TOC
 Return to Section TOC
 Return to Master TOC
 Return to Master TOC
 Return to Master TOC

TROUBLESHOOTING & REPAIR

AUXILIARY TRANSFORMER NO.1 TEST *(continued)*

TABLE F.5

LEAD IDENTIFICATION	NORMAL EXPECTED VOLTAGE
COM 2 (31) TO 115V (532)	115 VAC
42 TO COM 1A (quick connects)	42 VAC

7. Carefully apply the correct input voltage to the POWER WAVE® 355/405 and check for the correct secondary voltages per table F.5. Make sure the reconnect jumper lead and switch are configured correctly for the input voltage being applied. Make sure circuit breaker (CB3) is functioning properly.

NOTE: The secondary voltages will vary if the input line voltage varies.

8. If the correct secondary voltages are present, the auxiliary transformer is functioning properly. If any of the secondary voltages are missing or low, check to make certain the primary is configured correctly for the input voltage applied. See Wiring Diagram.



WARNING

High voltage is present at primary of Auxiliary Transformer.

9. If the correct input voltage is applied to the primary, and the secondary voltage(s) are not correct, the auxiliary transformer may be faulty.
10. Remove the input power to the POWER WAVE® 355/405.
11. Install the case wraparound cover using a 5/16" nut driver.

NOTES

Return to Section TOC
Return to Master TOC

Return to Section TOC
Return to Master TOC

Return to Section TOC
Return to Master TOC

Return to Section TOC
Return to Master TOC



TROUBLESHOOTING AND REPAIR

CURRENT TRANSDUCER TEST



WARNING

Service and repair should be performed by only Lincoln Electric factory trained personnel. Unauthorized repairs performed on this equipment may result in danger to the technician or machine operator and will invalidate your factory warranty. For your safety and to avoid electrical shock, please observe all safety notes and precautions detailed throughout this manual.

If for any reason you do not understand the test procedures or are unable to perform the test/repairs safely, contact the Lincoln Electric Service Department for electrical troubleshooting assistance before you proceed. Call 1-888-935-3877.

DESCRIPTION

This test will help determine if the current transducer and associated wiring are functioning correctly.

MATERIALS NEEDED

- Volt-ohmmeter
- 5/16" Nut Driver
- Grid Bank
- External DC Ammeter

TROUBLESHOOTING AND REPAIR

CURRENT TRANSDUCER TEST *(continued)*

FIGURE F.13 Metal Plate Removal & Plug J8 Location

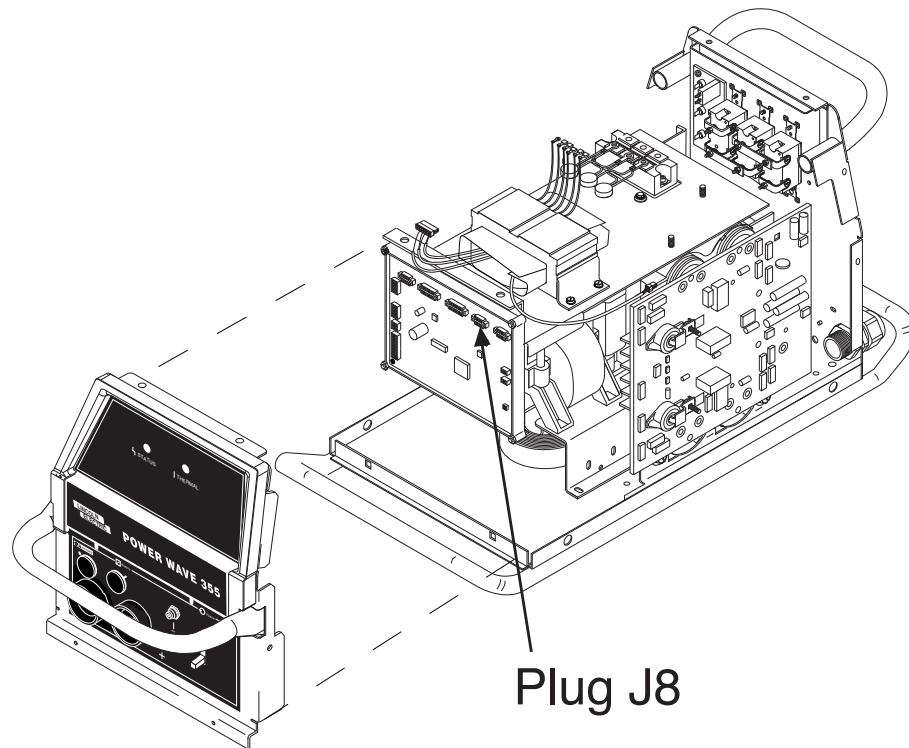

Plug J8

TEST PROCEDURE

1. Remove input power to the POWER WAVE® 355/405.
2. Using the 5/16" nut driver, remove the case wraparound cover.
3. Perform the **Input Capacitor Discharge Procedure**.
4. Locate plug J8 on the control board. Do not remove the plug from the P.C. Board.
5. Apply the correct input power to the POWER WAVE® 355/405.
6. Check for the correct DC supply voltages to the current transducer at plug J8. See Figure F.13.
 - A. Pin 2 (lead 802+) to pin 6 (lead 806-) should read +15 VDC.
 - B. Pin 4 (lead 804+) to pin 6 (lead 806-) should read -15 VDC.
7. If either of the supply voltages are low or missing, the control board may be faulty.

FIGURE F.14 Plug J8 Viewed From Lead Side of Plug

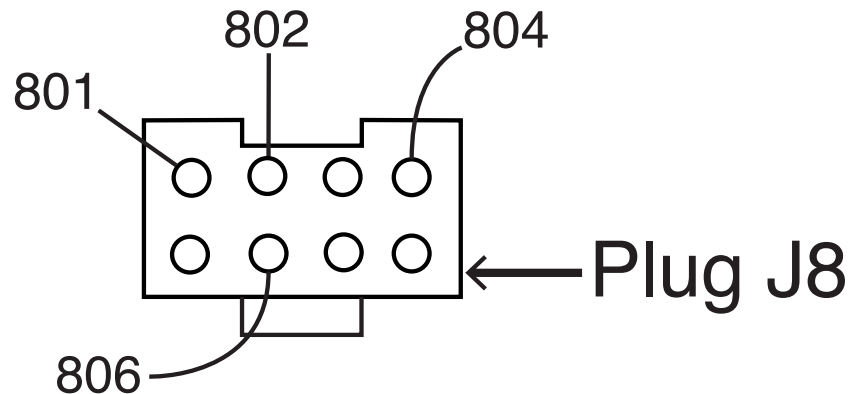

POWER WAVE® 355/405

LINCOLN
ELECTRIC

TROUBLESHOOTING AND REPAIR

CURRENT TRANSDUCER TEST *(continued)*

TABLE F.6

OUTPUT LOAD CURRENT	EXPECTED TRANSDUCER FEEDBACK VOLTAGE
300	2.4
250	2.0
200	1.6
150	1.2
100	0.8

8. Check the feedback voltage from the current transducer using a resistive load bank and with the POWER WAVE® 355/405 in mode 200. Mode 200 is a constant current test mode. This mode can be accessed using a wire feeder placed in mode 200 or a laptop computer and the appropriate software. Apply the grid load across the output of the POWER WAVE® 355/405. Set machine output to 300 amps and enable WELD TERMINALS. Adjust the grid load to obtain 300 amps on the external ammeter and check feedback voltages per Table F.6.
 - A. Pin 1 (lead 801) to Pin 6 (lead 806) should read 2.4 VDC (machine loaded to 300 amps).
9. If for any reason the machine cannot be loaded to 300 amps, Table F.6. shows what feedback voltage is produced at various current loads.
10. If the correct supply voltages are applied to the current transducer, and with the machine loaded, the feedback voltage is missing or not correct the current transducer may be faulty. Before replacing the current transducer, check the leads and plugs between the control board (J8) and the current transducer (J90). See The Wiring Diagram. For access to plug J90 and the current transducer refer to: ***Current Transducer Removal and Replacement Procedure.***
11. Remove input power to the POWER WAVE® 355/405.
12. Replace the control box top and any cable ties previously removed.
13. Install the case wraparound cover using the 5/16" nut driver.

NOTES

Return to Section TOC
Return to Master TOC

Return to Section TOC
Return to Master TOC

Return to Section TOC
Return to Master TOC

Return to Section TOC
Return to Master TOC

POWER WAVE® 355/405



TROUBLESHOOTING AND REPAIR

FAN CONTROL AND MOTOR TEST



WARNING

Service and repair should be performed by only Lincoln Electric factory trained personnel. Unauthorized repairs performed on this equipment may result in danger to the technician or machine operator and will invalidate your factory warranty. For your safety and to avoid electrical shock, please observe all safety notes and precautions detailed throughout this manual.

If for any reason you do not understand the test procedures or are unable to perform the test/repairs safely, contact the Lincoln Electric Service Department for electrical troubleshooting assistance before you proceed. Call 1-888-935-3877.

DESCRIPTION

This test will help determine if the fan motor, control board, switch board, or associated leads and connectors are functioning correctly.

MATERIALS NEEDED

Voltmeter

5/16" Nut Driver

TROUBLESHOOTING AND REPAIR

FAN CONTROL AND MOTOR TEST *(continued)*

TEST PROCEDURE

1. Remove the input power to the POWER WAVE® 355/405 machine.
2. Using the 5/16" nut driver, remove the case wraparound cover.
3. Perform the **Input Filter Capacitor Discharge Procedure**.
4. Locate plug J22 on the main switch board. Do not remove the plug from the board. See Figure F.15.

FIGURE F.15 PLUG J22 LOCATION

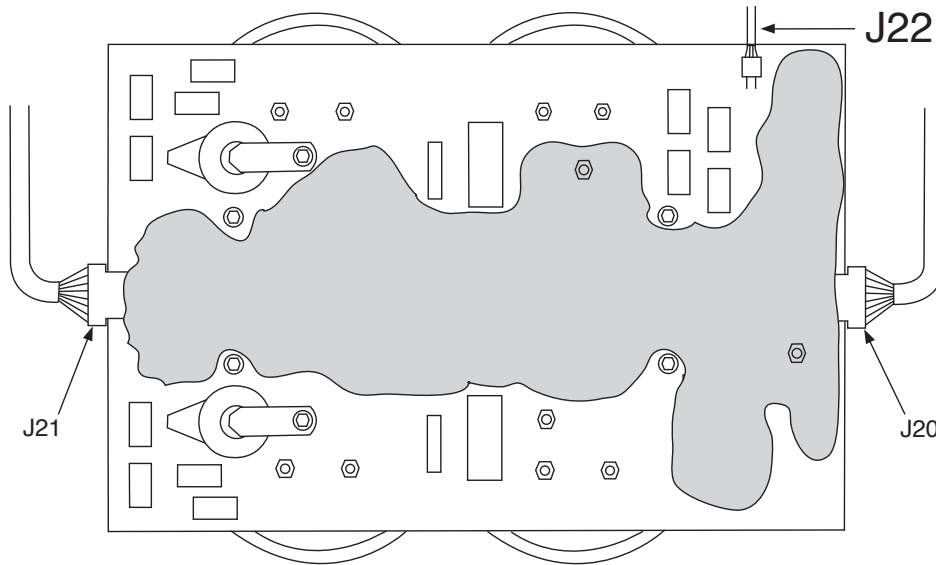

5. Carefully apply the correct input power to the machine.
6. Carefully check for 115VAC at plug J22 pin-2 to J22 pin-3. (leads 32A to 31B(C) See Figure F.16. **WARNING: HIGH VOLTAGE IS PRESENT AT THE MAIN SWITCH BOARD.**

FIGURE F.16 PLUG J22

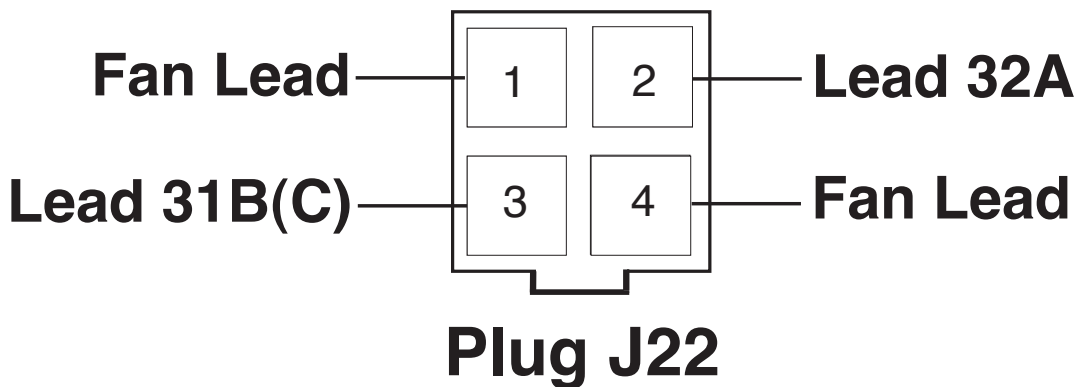

POWER WAVE® 355/405



Return to Section TOC

Return to Section TOC

Return to Section TOC

Return to Section TOC

Return to Master TOC

Return to Master TOC

Return to Master TOC

Return to Master TOC

TROUBLESHOOTING AND REPAIR

FAN CONTROL AND MOTOR TEST *(continued)*

7. If the 115VAC is low or not present check circuit breaker CB2 located on the front panel. If the circuit breaker is OK, perform **The Auxiliary Transformer Test**. Check plug J22, circuit breaker CB2 and associated leads for loose or faulty connections. See the Wiring Diagram.
8. Energize the weld output terminals with the PW 355/405 in mode 200. This mode can be accessed using a wire feeder placed in mode 200 or a laptop computer and the appropriate software. Carefully check for 115VAC at plug J22 pin-1 to J22 pin-4 (fan leads). **See Figure F.16**. If the 115VAC is present and the fan is not running then the fan motor may be faulty. Also check the associated leads between plug J22 and the fan motor for loose or faulty connections. See the Wiring Diagram. **WARNING: HIGH VOLTAGE IS PRESENT AT THE SWITCH BOARD.**
9. If the 115VAC is NOT present in the previous step then proceed to the fan control test.

FAN CONTROL TEST PROCEDURE

1. Locate plug J20 on the switch board. Do not remove the plug from the switch board. See **Figure F.15** and F.17.
2. Energize the weld output terminals (Select Weld Terminals ON) and carefully check for +15VDC at plug J20 pin-6+ to J20 pin-2- (leads 715 to 716). See Figure F.17. If the 15VDC is present and the fan is not running then the switch board may be faulty. If the 15VDC is not present when the weld terminals are energized then the control board may be faulty. Also check plugs J20, J7, and all associated leads for loose or faulty connections. See the Wiring Diagram.

WARNING: HIGH VOLTAGE IS PRESENT AT THE SWITCH BOARD.

3. Remove the input power to the POWER WAVE® 355/405.

Note: The fan motor may be accessed by the removal of the rear panel detailed in **The Current Transducer Removal and Replacement Procedure**.

4. Replace the case wrap-around cover.

FIGURE F.17 PLUG J20

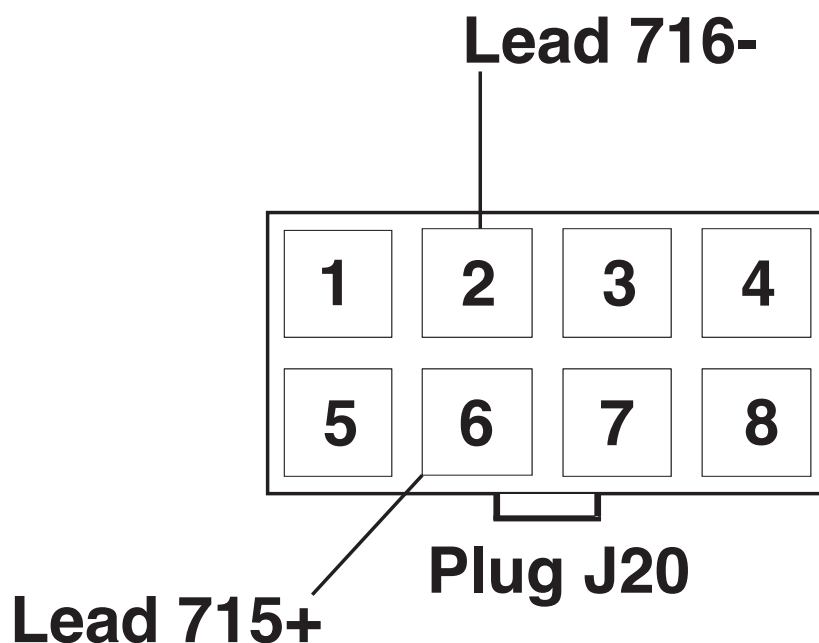

POWER WAVE® 355/405

LINCOLN
ELECTRIC

NOTES

Return to Section TOC
Return to Master TOC

Return to Section TOC
Return to Master TOC

Return to Section TOC
Return to Master TOC

Return to Section TOC
Return to Master TOC

POWER WAVE® 355/405



CONTROL BOARD REMOVAL AND REPLACEMENT



WARNING

Service and repair should be performed by only Lincoln Electric factory trained personnel. Unauthorized repairs performed on this equipment may result in danger to the technician or machine operator and will invalidate your factory warranty. For your safety and to avoid electrical shock, please observe all safety notes and precautions detailed throughout this manual.

If for any reason you do not understand the test procedures or are unable to perform the test/repairs safely, contact the Lincoln Electric Service Department for electrical troubleshooting assistance before you proceed. Call 1-888-935-3877.

DESCRIPTION

The following procedure will aid the technician in removing the control board for maintenance or replacement.

MATERIALS NEEDED

- 5/16" Nut Driver
- 3/8" Nut Driver
- Flathead Screwdriver
- Phillips Head Screwdriver

TROUBLESHOOTING & REPAIR

CONTROL BOARD REMOVAL AND REPLACEMENT *(continued)*

FIGURE F.18 - CONTROL BOARD LOCATION

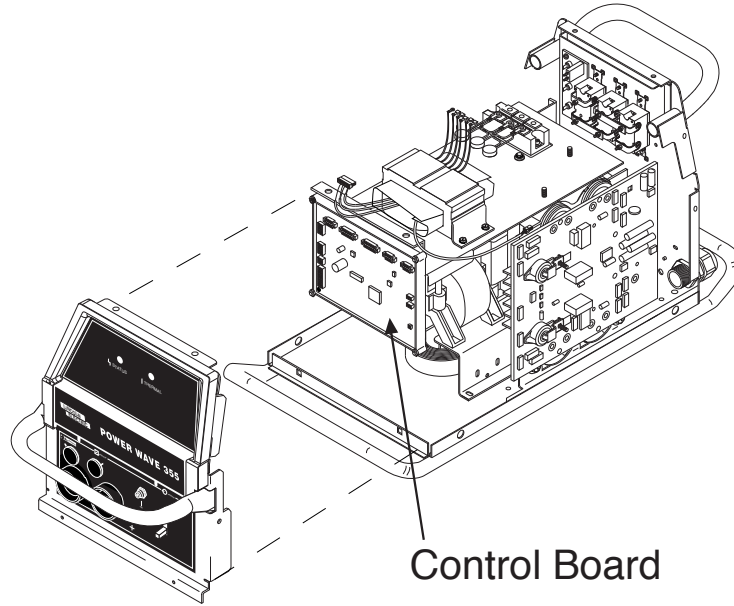

PROCEDURE

1. Remove input power to the POWER WAVE® 355/405.
2. Using a 5/16" nut driver remove the case wrap-around cover.
3. Perform the ***Input Filter Capacitor Discharge Procedure*** detailed earlier in this section.
4. Locate the control board behind the front panel of the machine. See Figure F.18.
5. Using a 5/16" nut driver remove the two screws from the bottom of the front of the machine. See Figure F.19.

FIGURE F.19 CASE FRONT SCREW REMOVAL

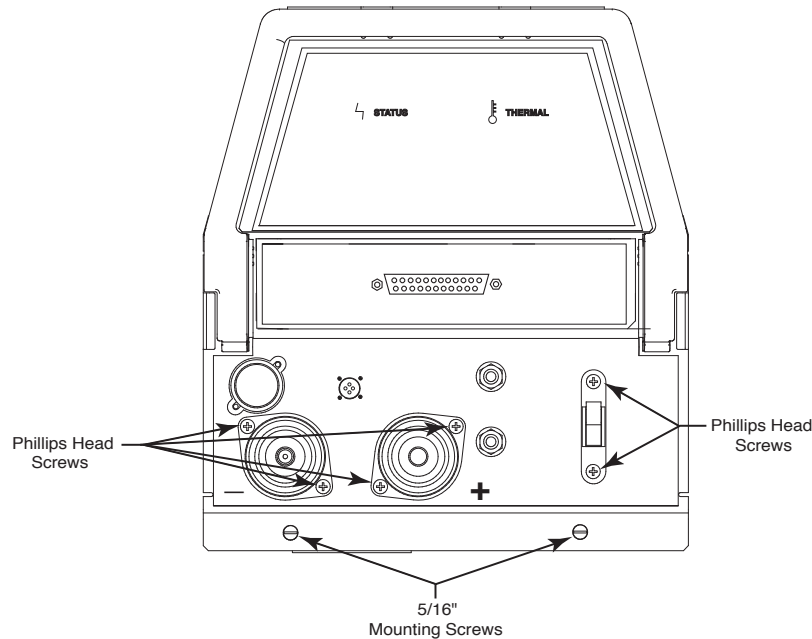

POWER WAVE® 355/405



Return to Section TOC
 Return to Section TOC
 Return to Section TOC
 Return to Master TOC
 Return to Master TOC
 Return to Master TOC

CONTROL BOARD REMOVAL AND REPLACEMENT *(continued)*

FIGURE F.20 - CONTROL BOARD ALL PLUG LOCATIONS

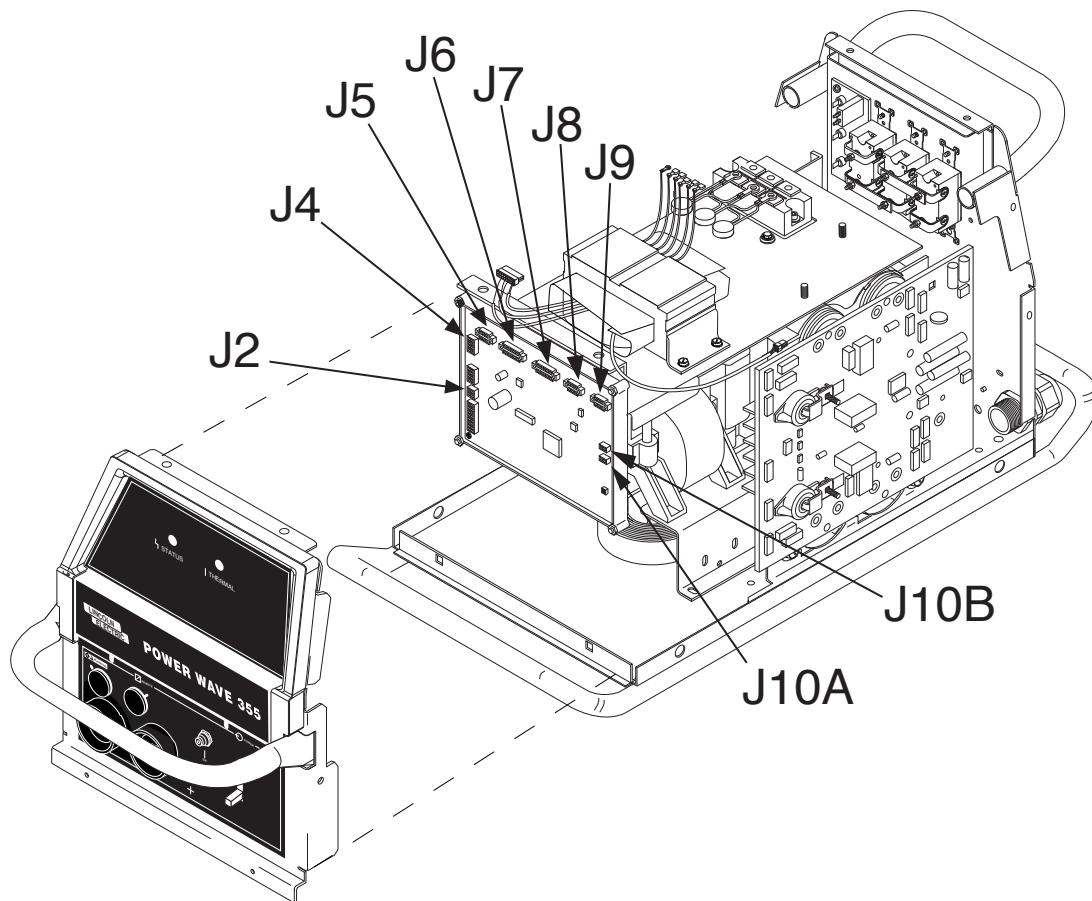

⚠ CAUTION

Observe static precautions detailed in **PC Board Troubleshooting Procedures** at the beginning of this section.

6. Using a phillips head screwdriver remove the two screws and their washers from above and below the input power switch. See **Figure F.19**.
7. Using a phillips head screwdriver remove the four screws from around the two welder output terminals on the front of the machine. See **Figure F.19**.
8. The front of the machine may now gently be pulled forward to gain access to the Control Board. Note: The front of the machine cannot be removed completely, only pulled forward a few inches.
9. Beginning at the right side of the control board remove plugs J10A and J10B. Note: Be sure to label each plugs position upon removal. See Figure F.20.
10. Working your way across the top of the board from right to left, label and remove plugs #J9, #J8, #J7, #J6, and #J5. See Figure F.20.
11. Working your way down the left side of the board, label and remove plugs #J4 and #J2. See Figure F.20.

POWER WAVE® 355/405

LINCOLN
ELECTRIC

TROUBLESHOOTING & REPAIR

CONTROL BOARD REMOVAL AND REPLACEMENT *(continued)*

12. Using a 3/8" nut driver remove the two mounting nuts from the top two corners of the control board. See Figure F.21.
13. Cut any necessary cable ties.
14. Replace the control board.

FIGURE F.21 CONTROL BOARD MOUNTING SCREW LOCATION

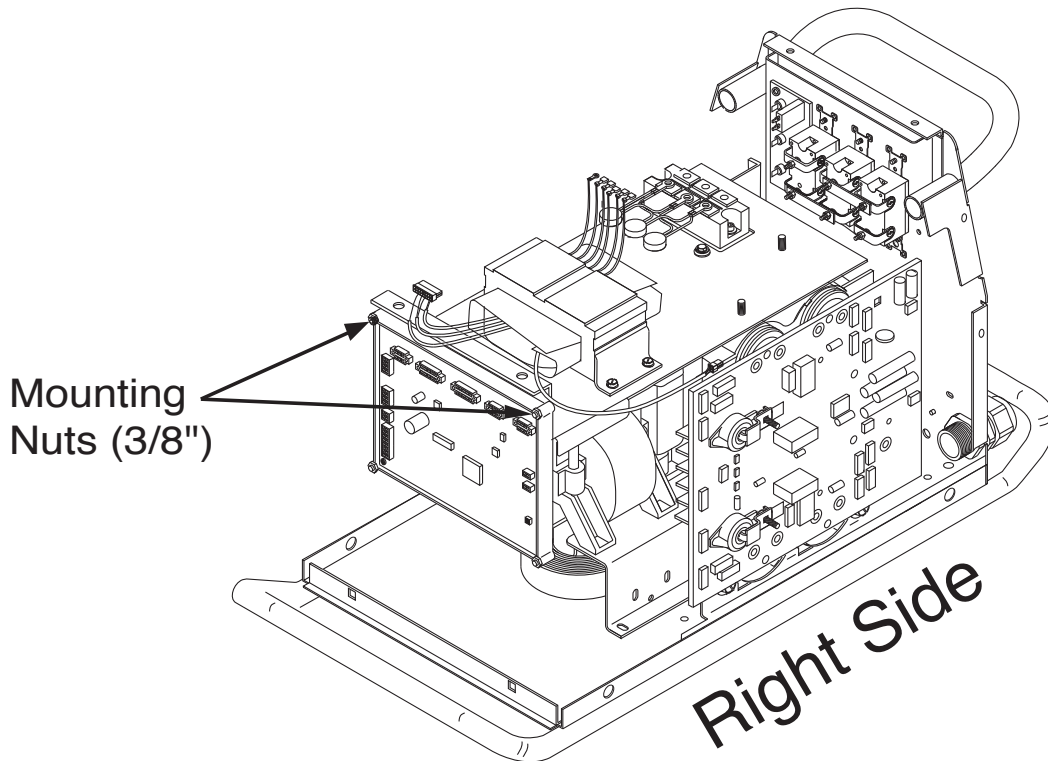

15. Replace the two 3/8" mounting nuts at the top two corners of the control board.
16. Replace any previously removed cable ties.
17. Replace plugs #J2, #J4, #J5, #J6, #J7, #J8, #J9, #J10B, and #J10A previously removed.
18. Replace the two screws and their washers from above and below the input power switch.
19. Replace the four screws from around the two welder output terminals on the front of the machine.
20. Replace the two case front mounting screws at the bottom of the front of the machine.
21. Replace the case wraparound cover.

TROUBLESHOOTING & REPAIR

MAIN SWITCH BOARD REMOVAL AND REPLACEMENT



WARNING

Service and repair should be performed by only Lincoln Electric factory trained personnel. Unauthorized repairs performed on this equipment may result in danger to the technician or machine operator and will invalidate your factory warranty. For your safety and to avoid electrical shock, please observe all safety notes and precautions detailed throughout this manual.

If for any reason you do not understand the test procedures or are unable to perform the test/repairs safely, contact the Lincoln Electric Service Department for electrical troubleshooting assistance before you proceed. Call 1-888-935-3877.

DESCRIPTION

The following procedure will aid the technician in removing the main switch board for maintenance or replacement.

MATERIALS NEEDED

- 5/16" Nut Driver
- Flathead Screwdriver
- 7/16" mm Socket
- 3/16" Allen Wrench
- 3/8" Nut Driver

MAIN SWITCH BOARD REMOVAL & REPLACEMENT (continued)

FIGURE F.22 – MAIN SWITCH BOARD LEAD LOCATIONS

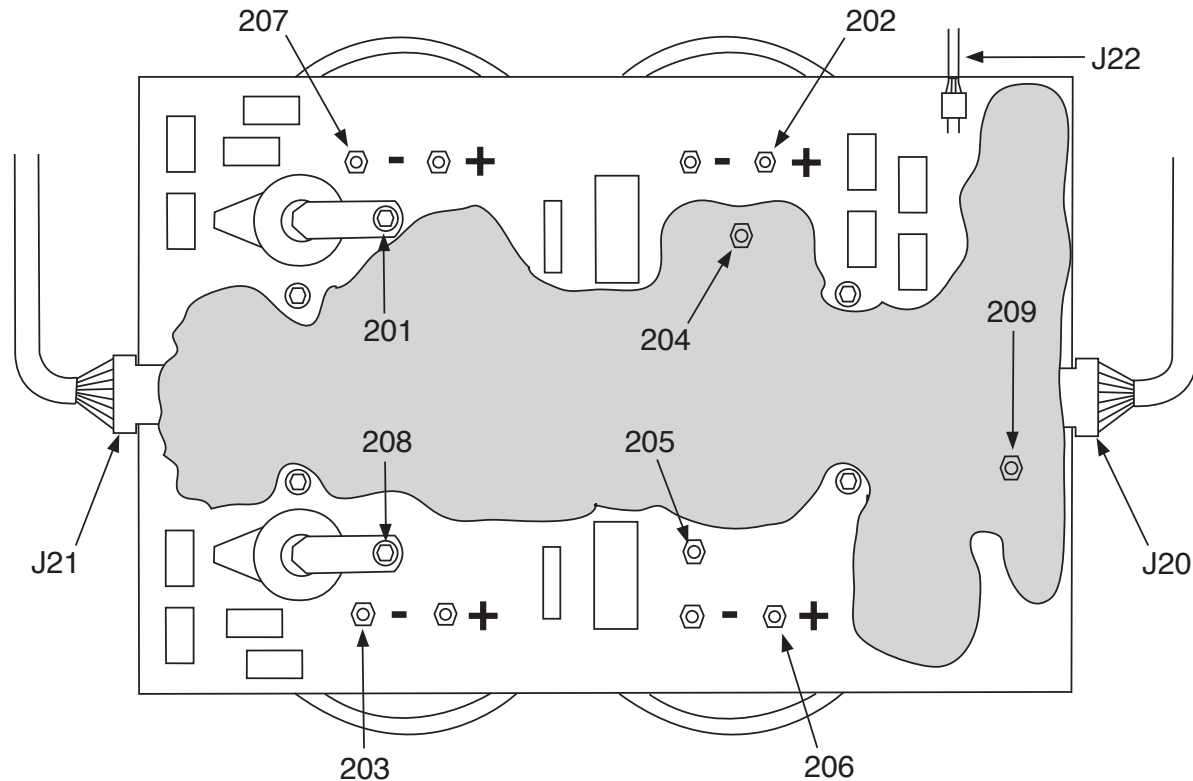

PROCEDURE

1. Remove the input power to the POWER WAVE® 355/405.
2. Using a 5/16" nut driver remove the case wrap-around cover.
3. Perform the **Input Filter Capacitor Discharge Procedure** detailed earlier in this section.
4. Locate the main switch board and all associated plug and lead connections. See figure F.22. See Wiring Diagram.
5. Using a 3/8" nut driver, remove the input lead shield from the area at the bottom of the main switch board.
6. Using a 7/16" socket, remove leads 201, 202, 203, 204, 205, 206, 207, 208, 209 from the switch board. Note lead terminal locations and washer positions upon removal.
7. Locate and disconnect the three harness plugs associated with the main switch board. Plugs #J20, #J21, #J22. See Figure F.22.
8. Locate the eight capacitor terminals and remove the nuts using a 7/16" socket or nut driver. Note the position of the washers behind each nut for replacement.

CAUTION

Observe static precautions detailed in **PC Board Troubleshooting Procedures** at the beginning of this section. Failure to do so can result in permanent damage to equipment.

MAIN SWITCH BOARD REMOVAL & REPLACEMENT *(continued)*

FIGURE F.23 – 3/16" ALLEN BOLT LOCATION

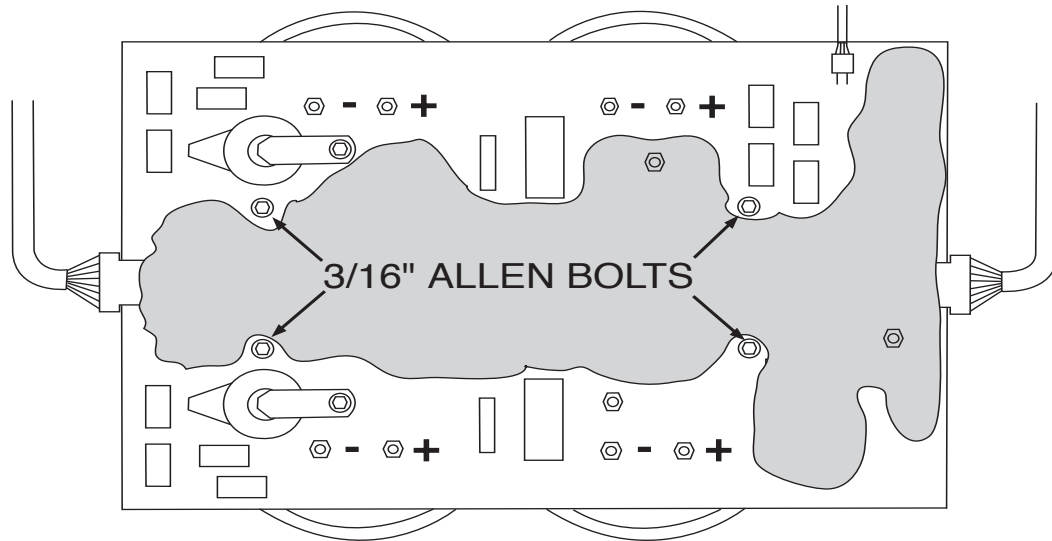

9. Using a 3/16" allen wrench remove four allen bolts and washers as shown in Figure F.23. At this point, the board is ready for removal.
10. Carefully maneuver the board out of the machine.
11. Apply a thin coat of Penetrox A-13 to the IGBT heatsinks on the back of the new switch boards mating surfaces. Note: Keep compound away from the mounting holes.
12. Replace the four allen bolts and washers previously removed.
13. Replace the eight capacitor terminal nuts, washers, and necessary leads previously removed.
14. Reconnect the three harness plugs previously removed.
15. Reconnect the nine leads (#201-#209) that were previously removed.
16. Replace any necessary cable ties previously removed.
17. Pre-torque all screws to 25 inch lbs. before tightening to 44 inch lbs.
18. Replace the input lead shield previously removed.
19. Replace the case wraparound cover.

NOTES

Return to Section TOC
Return to Master TOC

Return to Section TOC
Return to Master TOC

Return to Section TOC
Return to Master TOC

Return to Section TOC
Return to Master TOC

POWER WAVE® 355/405



TROUBLESHOOTING & REPAIR

SNUBBER BOARD REMOVAL AND REPLACEMENT



WARNING

Service and repair should be performed by only Lincoln Electric factory trained personnel. Unauthorized repairs performed on this equipment may result in danger to the technician or machine operator and will invalidate your factory warranty. For your safety and to avoid electrical shock, please observe all safety notes and precautions detailed throughout this manual.

If for any reason you do not understand the test procedures or are unable to perform the test/repairs safely, contact the Lincoln Electric Service Department for electrical troubleshooting assistance before you proceed. Call 1-888-935-3877.

DESCRIPTION

The following procedure will aid the technician in removing the snubber board for maintenance or replacement.

MATERIALS NEEDED

5/16" Nut Driver

7/16 Socket or Nut Driver

TROUBLESHOOTING & REPAIR

SNUBBER BOARD REMOVAL AND REPLACEMENT (continued)

PROCEDURE

1. Remove input power to the POWER WAVE® 355/405.
2. Using a 5/16" nut driver remove the case wrap-around cover.
3. Perform the **Input Filter Capacitor Discharge Procedure** detailed earlier in this section.
4. Locate the snubber board. See Figure F.24.

FIGURE F.24 – SNUBBER BOARD LOCATION

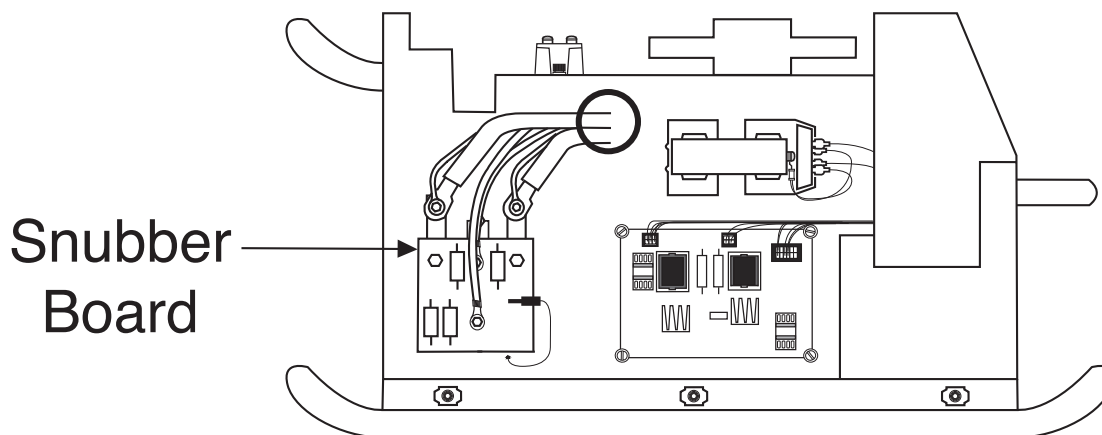

LEFT SIDE

5. Remove small lead #B1 from the board. See Figure F.25.
6. Remove the four bolts using a 7/16" socket. Two of these bolts have leads #30 and #10 connected to them. Note the position of all leads and associated washers upon removal.
7. Carefully remove the snubber board.
8. Replace the snubber board.
9. Replace the bolts, leads, and washers previously removed. Torque bolt to 30-40 Inch Lbs.
10. Reconnect small lead B1 previously removed.
11. Replace the case wraparound cover.

FIGURE F.25 – SNUBBER BOARD LEADS (CLOSE UP)

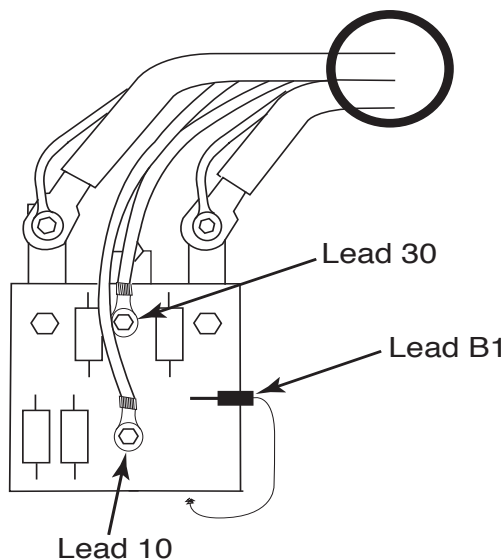

POWER WAVE® 355/405

TROUBLESHOOTING & REPAIR

POWER BOARD REMOVAL AND REPLACEMENT



WARNING

Service and repair should be performed by only Lincoln Electric factory trained personnel. Unauthorized repairs performed on this equipment may result in danger to the technician or machine operator and will invalidate your factory warranty. For your safety and to avoid electrical shock, please observe all safety notes and precautions detailed throughout this manual.

If for any reason you do not understand the test procedures or are unable to perform the test/repairs safely, contact the Lincoln Electric Service Department for electrical troubleshooting assistance before you proceed. Call 1-888-935-3877.

DESCRIPTION

The following procedure will aid the technician in removing the power board for maintenance or replacement.

MATERIALS NEEDED

5/16" Nut Driver

3/8" Nut Driver

TROUBLESHOOTING & REPAIR

POWER BOARD REMOVAL AND REPLACEMENT *(continued)*

FIGURE F.26 POWER BOARD LOCATION

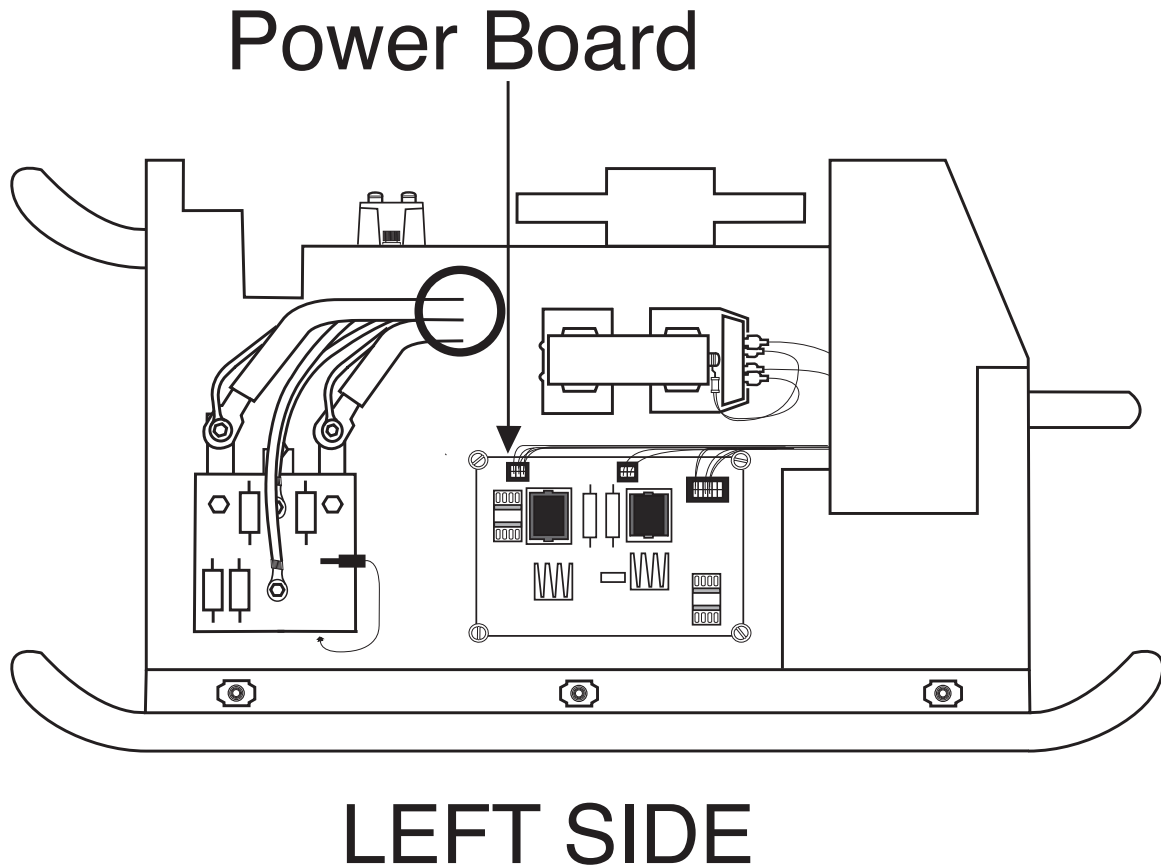

PROCEDURE

1. Remove input power to the POWER WAVE® 355/405.
2. Using a 5/16" nut driver remove the case wrap-around cover.
3. Perform the ***Input Filter Capacitor Discharge Procedure*** detailed earlier in this section.
4. Locate the power board. See Figure F.26.

POWER WAVE® 355/405



TROUBLESHOOTING & REPAIR

POWER BOARD REMOVAL AND REPLACEMENT *(continued)*

⚠ CAUTION

Observe static precautions detailed in **PC Board Troubleshooting Procedures** at the beginning of this section.

5. Locate the three plug connections. J41, J42 and J43 on the Power Board. See figure F.27.
6. Carefully disconnect the three plugs from the Power Board.
7. Remove the three nuts at the corners of the board using a 3/8" nut driver. Board is ready for removal.
8. Replace the power board.
9. Secure the new power board into its proper position with the three 3/8" nuts previously removed.
10. Reconnect the three plugs previously removed. Plugs J41, J42 and J43.
11. Replace the case wraparound cover.

FIGURE F.27 – POWER BOARD LEAD LOCATION

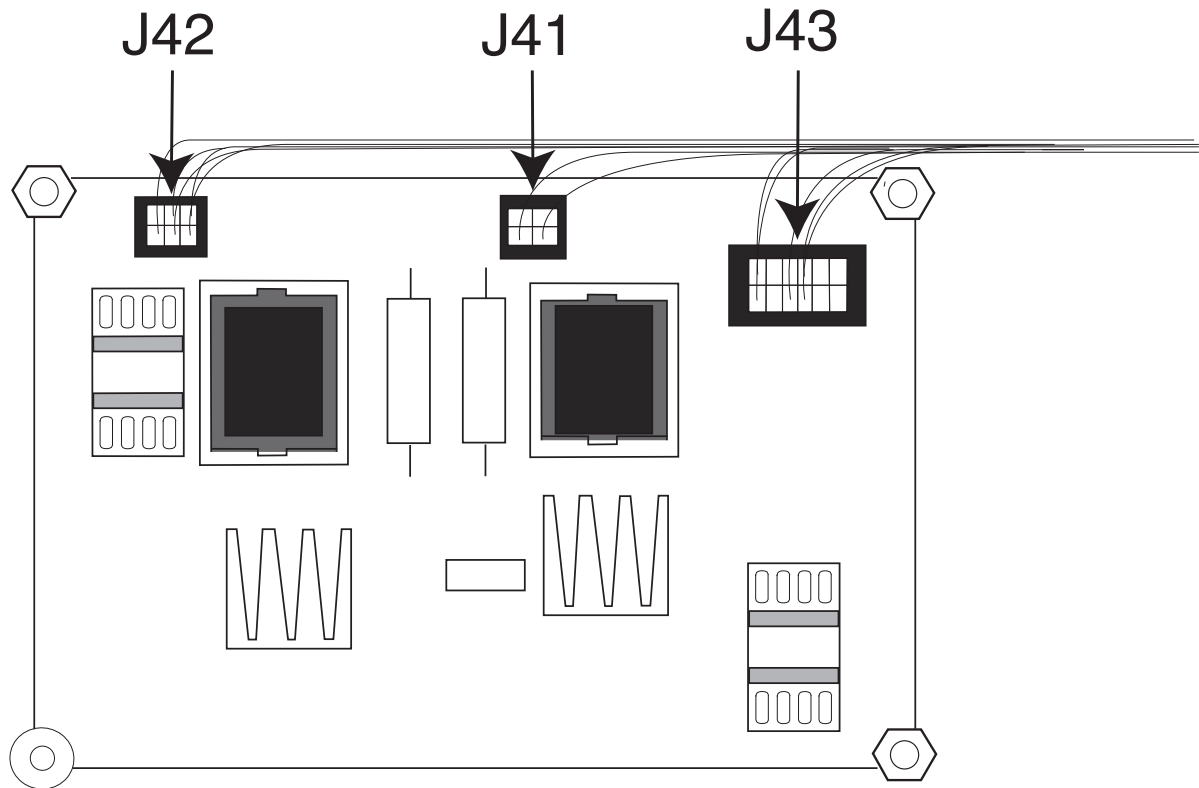

NOTES

Return to Section TOC

Return to Section TOC

Return to Section TOC

Return to Section TOC

Return to Master TOC

Return to Master TOC

Return to Master TOC

Return to Master TOC

POWER WAVE® 355/405



TROUBLESHOOTING & REPAIR

DC BUS BOARD REMOVAL AND REPLACEMENT



WARNING

Service and repair should be performed by only Lincoln Electric factory trained personnel. Unauthorized repairs performed on this equipment may result in danger to the technician or machine operator and will invalidate your factory warranty. For your safety and to avoid electrical shock, please observe all safety notes and precautions detailed throughout this manual.

If for any reason you do not understand the test procedures or are unable to perform the test/repairs safely, contact the Lincoln Electric Service Department for electrical troubleshooting assistance before you proceed. Call 1-888-935-3877.

DESCRIPTION

The following procedure will aid the technician in removing the DC Bus Board for maintenance or replacement.

MATERIALS NEEDED

- 5/16" Nut Driver
- 3/8" Open End Wrench
- Flat Head Screwdriver
- Phillips Head Screwdriver

TROUBLESHOOTING & REPAIR

DC BUS BOARD REMOVAL AND REPLACEMENT (*Continued*)

PROCEDURE

1. Remove input power to the POWER WAVE® 355/405.
2. Using a 5/16" nut driver remove the case wrap-around cover.
3. Perform the **Input Filter Capacitor Discharge Procedure** detailed earlier in this section.
4. Locate the DC Bus Board. See Figure F.28.
5. Using a 5/16" nut driver remove the two screws from the bottom of the front of the machine. See **Figure F.29**.
6. Using a phillips head screwdriver remove the two screws and their washers from above and below the input power switch. See **Figure F.29**.
7. Using a phillips head screwdriver remove the four screws mounting the two welder output terminals on the front of the machine. See **Figure F.29**.
8. The front of the machine may now gently be pulled forward to gain access to the DC Bus Board. Note: The front of the machine cannot be removed completely, only pulled forward a few inches.

FIGURE F.28 DC BUS BOARD LOCATION

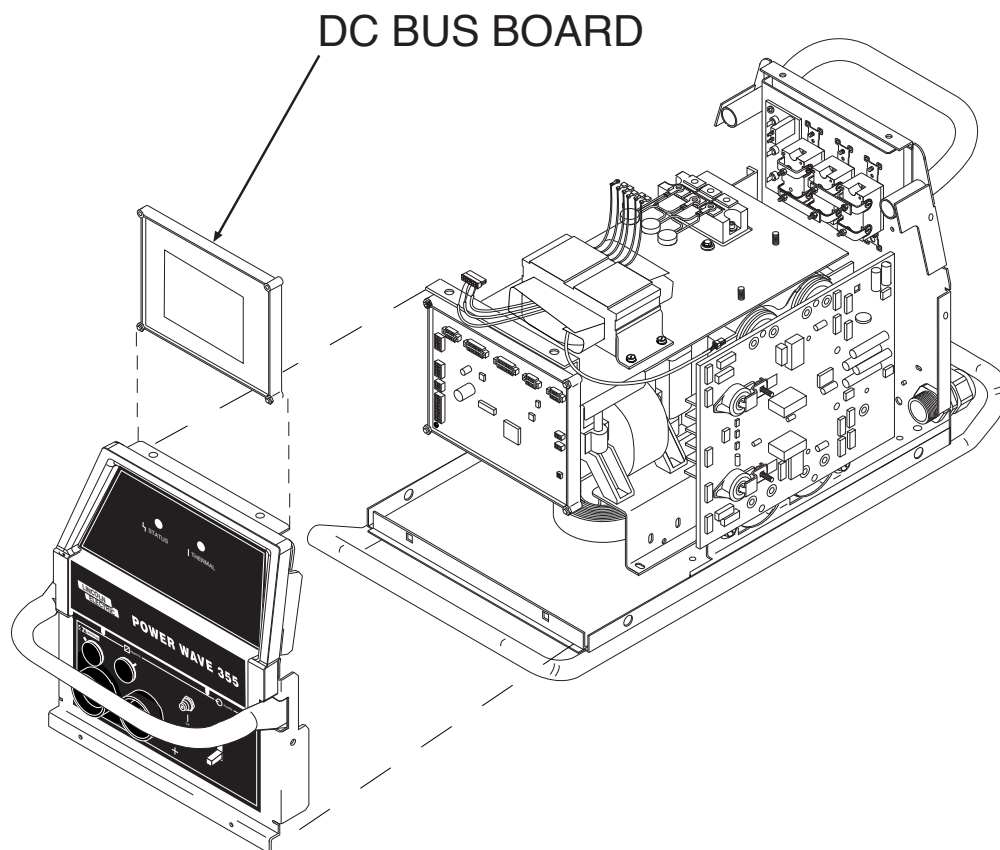

POWER WAVE® 355/405



TROUBLESHOOTING & REPAIR

DC BUS BOARD REMOVAL AND REPLACEMENT (Continued)

FIGURE F.29 CASE FRONT SCREW REMOVAL

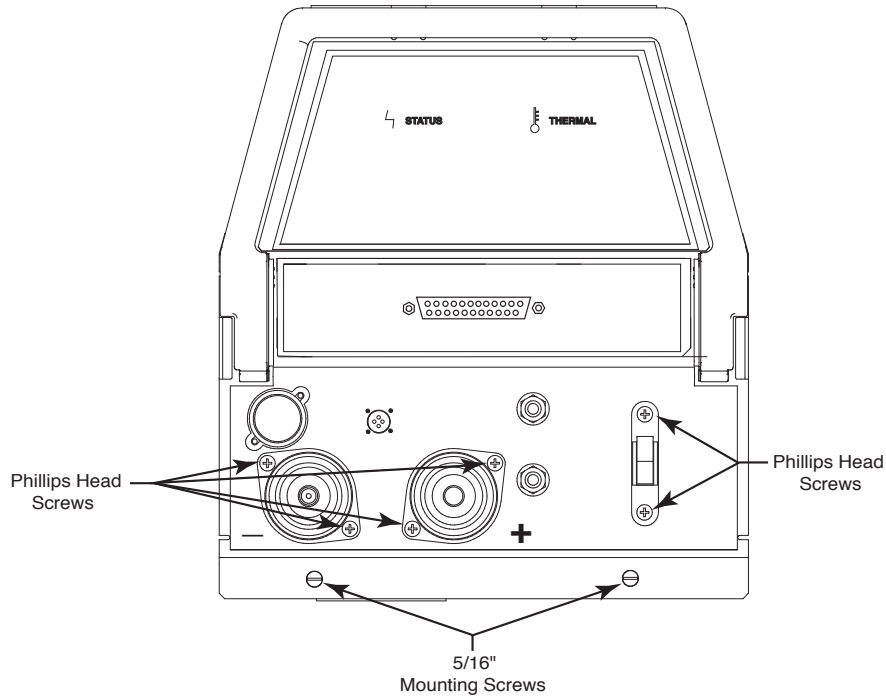

- | | |
|--|--|
| <p>9. Label and remove two thermostat leads and four leads from the bus rectifier.</p> <p>10. Using a 3/8" open end wrench, remove the three DC Bus Board mounting nuts. See Figure F.30.</p> <p>11. Replace the DC Bus Board.</p> <p>12. Secure the new DC Bus Board in its proper location using the 3/8" mounting nuts.</p> | <p>13. Reconnect previously removed leads to their proper locations.</p> <p>14. Replace the four phillips head screws mounting the two welder output terminals to the front of the machine.</p> <p>15. Replace the two phillips head screws from above and below the input power switch.</p> |
|--|--|

FIGURE F.30 CASE FRONT SCREW REMOVAL

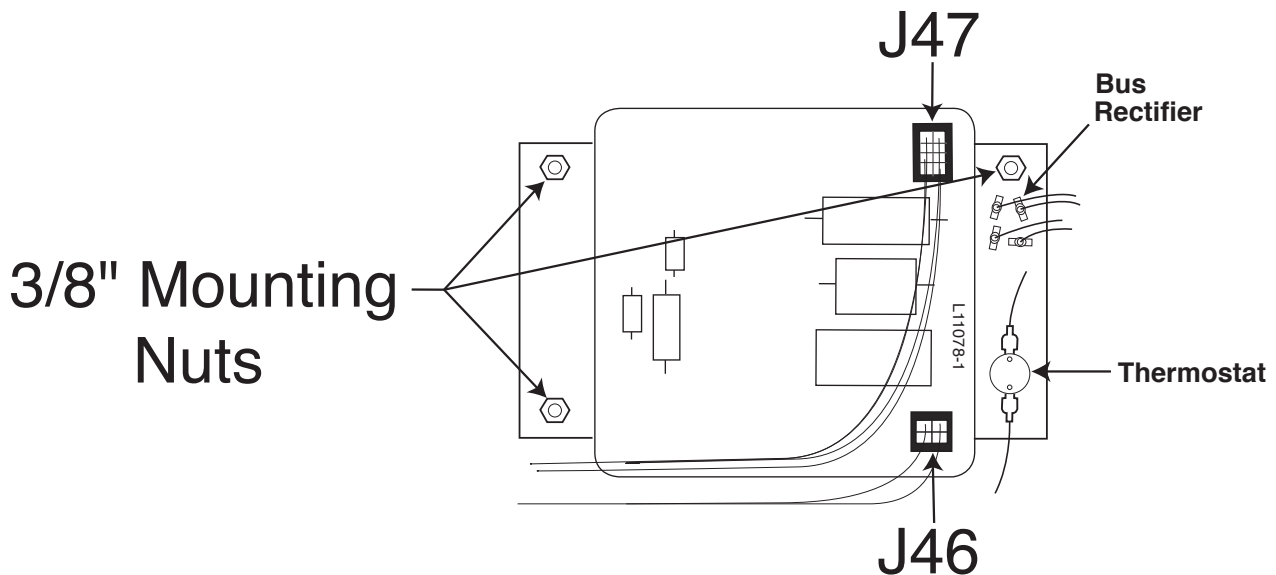

Return to Section TOC
Return to Master TOC

TROUBLESHOOTING & REPAIR

DC BUS BOARD REMOVAL AND REPLACEMENT *(Continued)*

16. Replace the two 5/16" mounting screws to the bottom of the case front.

17. Replace the case wraparound cover.

Return to Section TOC
Return to Master TOC
Return to Section TOC
Return to Master TOC
Return to Section TOC
Return to Master TOC
Return to Section TOC
Return to Master TOC

TROUBLESHOOTING & REPAIR

INPUT RECTIFIER REMOVAL AND REPLACEMENT



WARNING

Service and repair should be performed by only Lincoln Electric factory trained personnel. Unauthorized repairs performed on this equipment may result in danger to the technician or machine operator and will invalidate your factory warranty. For your safety and to avoid electrical shock, please observe all safety notes and precautions detailed throughout this manual.

If for any reason you do not understand the test procedures or are unable to perform the test/repairs safely, contact the Lincoln Electric Service Department for electrical troubleshooting assistance before you proceed. Call 1-888-935-3877.

DESCRIPTION

The following procedure will aid the technician in removing the input rectifier for maintenance or replacement.

MATERIALS NEEDED

- 3/16" Allen wrench
- 5/16" Nut Driver
- Flathead Screwdriver
- Penetrox A-13 Heatsink Compound
- Silicon Sealant

TROUBLESHOOTING & REPAIR

INPUT RECTIFIER REMOVAL AND REPLACEMENT *(continued)*

PROCEDURE

1. Remove input power to the POWER WAVE® 355/405.
2. Using a 5/16" nut driver remove the case wrap-around cover.
3. Perform the **Input Filter Capacitor Discharge Procedure** detailed earlier in this section.
4. Locate the input rectifier. See figure F.31.
5. Carefully remove the silicon sealant insulating the six input rectifier terminals.
6. Remove the six screws from the terminals using a flathead screwdriver. Carefully note the position of all leads and their positions upon removal. **See Figure F.32.**
7. Using a 3/16" allen wrench remove the two mounting screws and washers from the input bridge. **See Figure F.32.**
8. Remove the input bridge.

FIGURE F.31 – INPUT RECTIFIER LOCATION

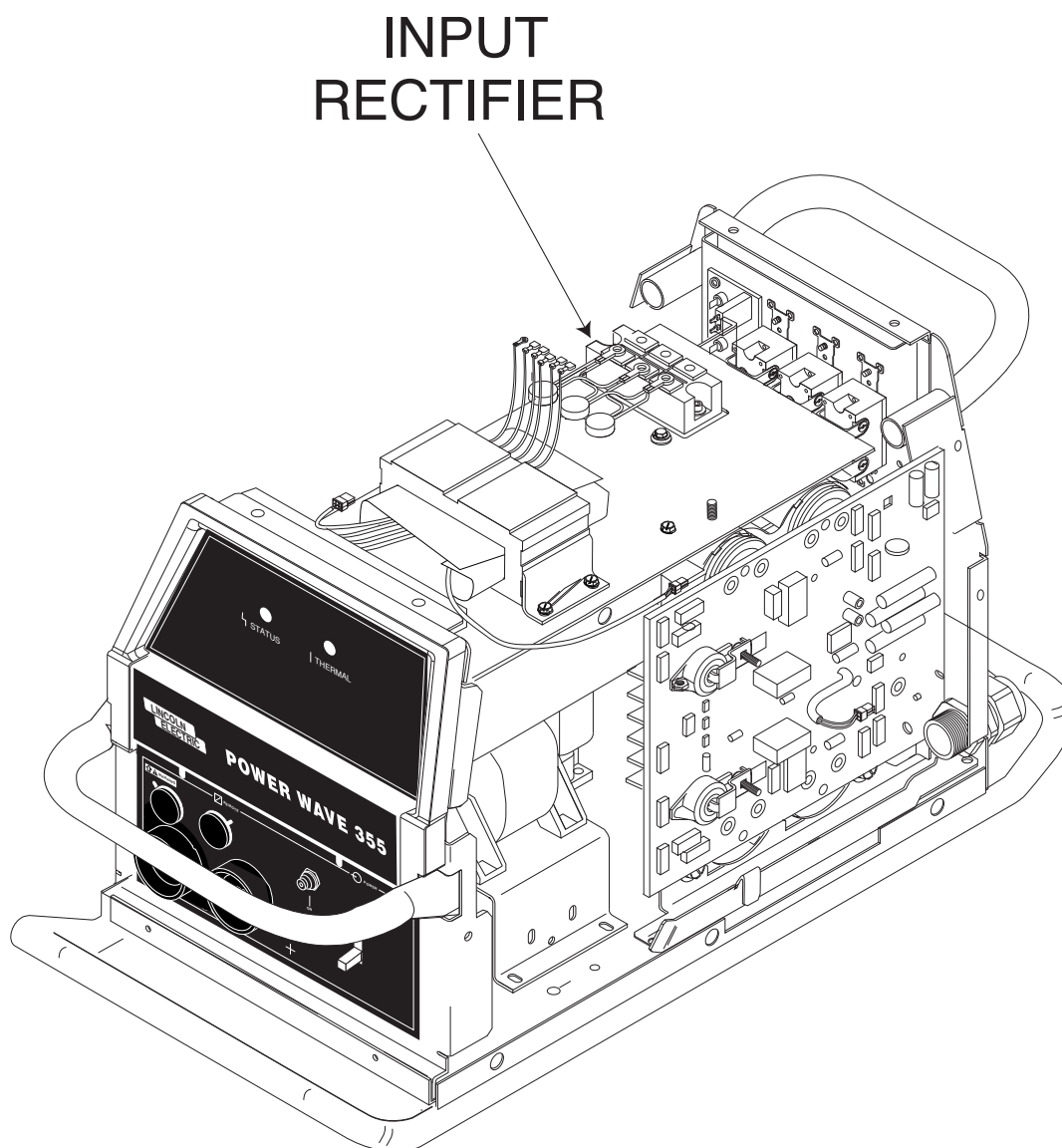

POWER WAVE® 355/405



TROUBLESHOOTING & REPAIR

INPUT RECTIFIER REMOVAL AND REPLACEMENT *(continued)*

9. Apply a thin coat of Penetrox A-13 heatsink compound to the point of contact between the input rectifier and the mounting surface.
10. Secure the new input bridge into its proper position with the two 3/16" allen mounting screws previously removed. Torque to 44 inch pounds.
11. Reconnect the previously removed leads to their proper locations. Torque to 31 inch pounds.
12. Cover the input rectifier and its six terminals with silicon sealant.
13. Replace the case wraparound cover.

FIGURE F.32 – INPUT RECTIFIER (CLOSE-UP)

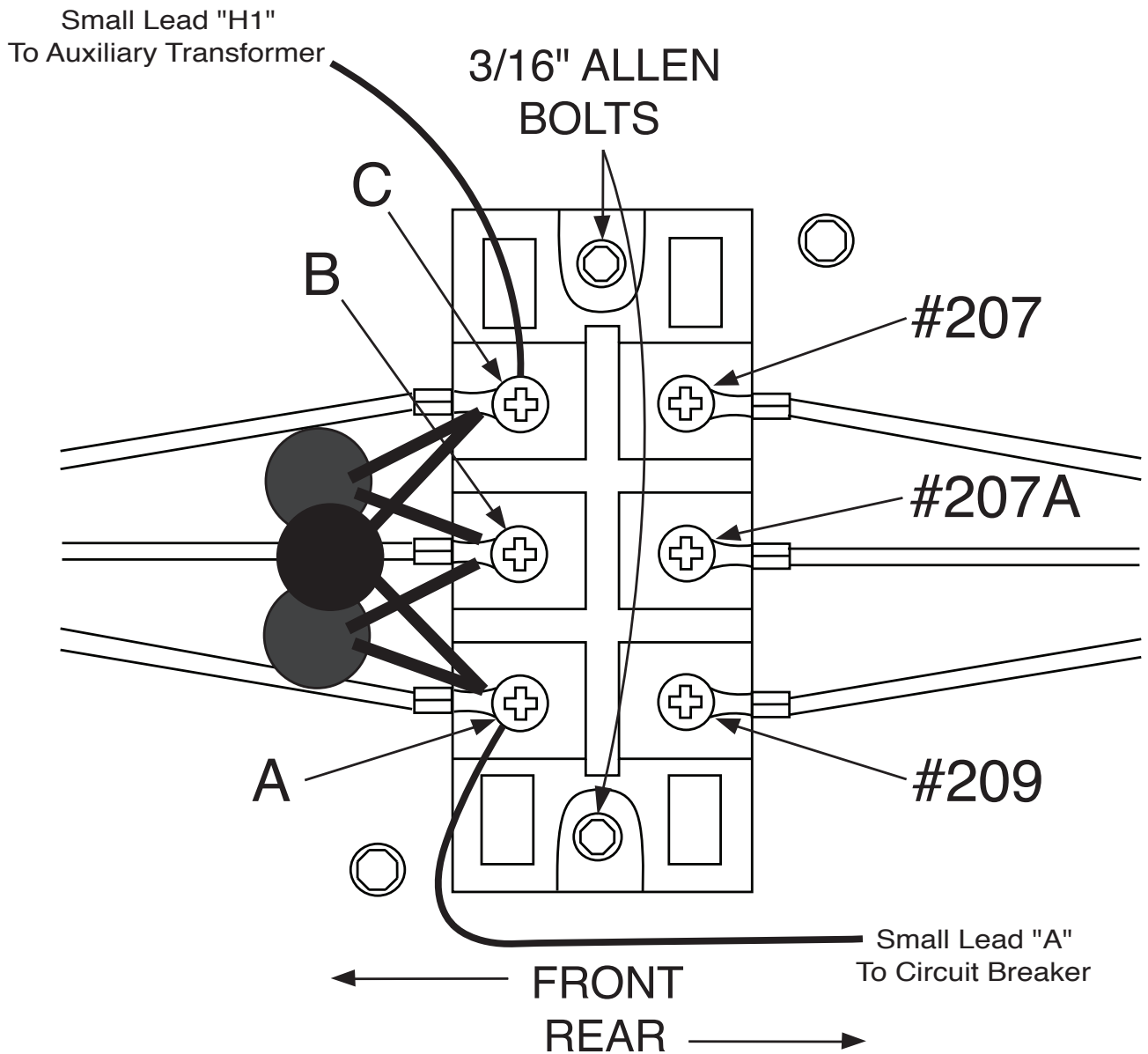

NOTES

Return to Section TOC Return to Section TOC Return to Section TOC Return to Section TOC
Return to Master TOC Return to Master TOC Return to Master TOC Return to Master TOC

POWER WAVE® 355/405



TROUBLESHOOTING & REPAIR

OUTPUT RECTIFIER MODULES REMOVAL AND REPLACEMENT



WARNING

Service and repair should be performed by only Lincoln Electric factory trained personnel. Unauthorized repairs performed on this equipment may result in danger to the technician or machine operator and will invalidate your factory warranty. For your safety and to avoid electrical shock, please observe all safety notes and precautions detailed throughout this manual.

If for any reason you do not understand the test procedures or are unable to perform the test/repairs safely, contact the Lincoln Electric Service Department for electrical troubleshooting assistance before you proceed. Call 1-888-935-3877.

DESCRIPTION

The following procedure will aid the technician in removing the output rectifier modules for maintenance or replacement.

MATERIALS NEEDED

- 3/16" Allen wrench
- 9/64" Allen wrench
- 5/16" Nut Driver
- 7/16" Wrench
- Flathead Screwdriver
- Penetrox A-13 Heatsink Compound
- Thin Knife/Screwdriver

TROUBLESHOOTING & REPAIR

OUTPUT RECTIFIER MODULES

REMOVAL AND REPLACEMENT *(continued)*

PROCEDURE

1. Remove input power to the POWER WAVE® 355/405.
2. Using a 5/16" nut driver remove the case wrap-around cover.
3. Perform the **Input Filter Capacitor Discharge Procedure** detailed earlier in this section.
4. Locate the output diode modules located behind the snubber board. See figure F.33.
5. Before the output rectifier modules can be reached, the **Snubber Board Removal Procedure** must be performed.
6. After the snubber board is removed, remove the four leads connected to the modules using a 3/16" allen wrench. These leads are #X4, #X2, #20, #40. Note their positions for reassembly. **See Figure F.34.**
7. Remove the copper plates from the tops of the modules.

FIGURE F.33 – OUTPUT RECTIFIER MODULE LEAD LOCATIONS

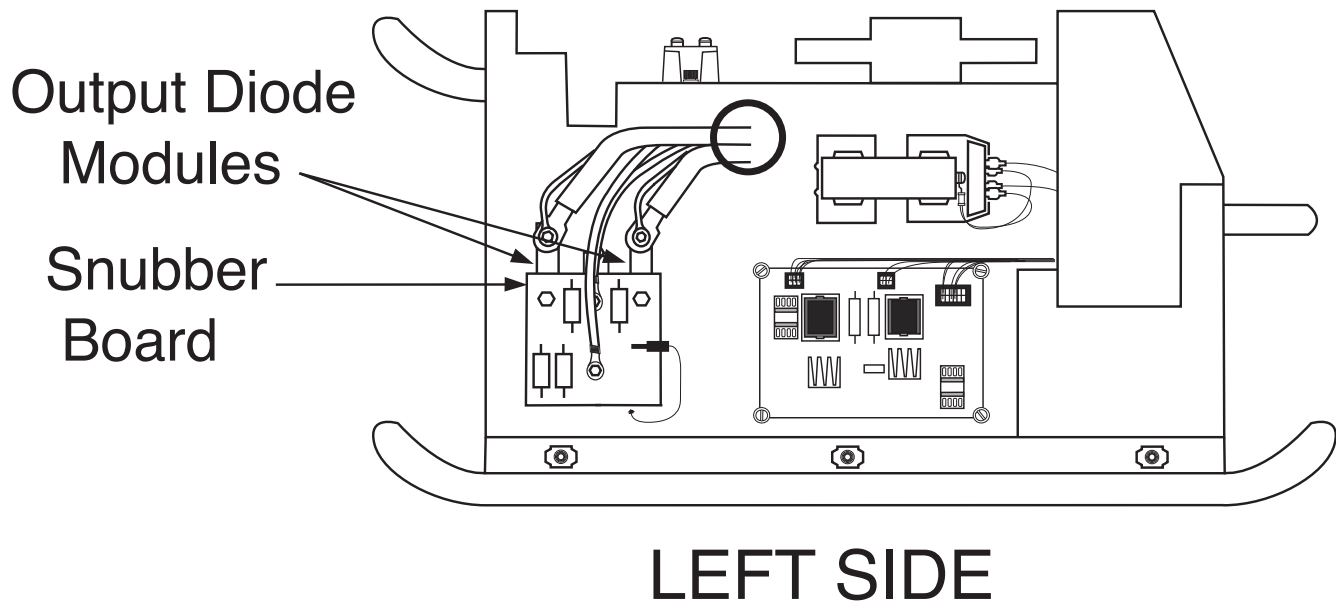

TROUBLESHOOTING & REPAIR

OUTPUT RECTIFIER MODULES

REMOVAL AND REPLACEMENT *(continued)*

8. Under the copper plate previously removed, there is an allen bolt. Remove it using a 9/64" allen wrench. See Figure F.34.
9. Using a 7/16" socket remove the mounting bolts at the top and bottom of the modules. See Figure F.34.
10. The output rectifier modules are ready for removal and/or replacement.
11. Before replacing the diode module, apply a thin even coat of Penetrox A-13 heatsink compound to the bottom surface of the diode module. Note: Keep the compound away from the mounting holes.
12. Press the module firmly against the sink while aligning the mounting holes. Insert each outer screw through a spring washer and then a plain washer and into the holes. Start threading all three screws into the heat sink (2 or 3 turns by hand).
13. The screw threads may catch on the threads of the heat sink, so be sure to get the face of the screw into contact with the surface of the module (using just hand torque).
14. Using a 7/16" socket, tighten each mounting bolt to between 5 and 10 inch pounds.
15. Tighten the center allen screw to between 12 and 18 inch pounds.
16. Tighten each mounting bolt again (30 to 40 inch pounds this time).
15. Replace leads #X2, #X4, #20, #40 to their original terminals in their proper positions. Torque bolts to 30-40 Inch Pounds.
16. Perform the **Snubber Board Replacement Procedure** detailed earlier in this section.
17. Replace the case wraparound cover.

FIGURE F.34 – OUTPUT RECTIFIER MODULE MOUNTING BOLT LOCATIONS

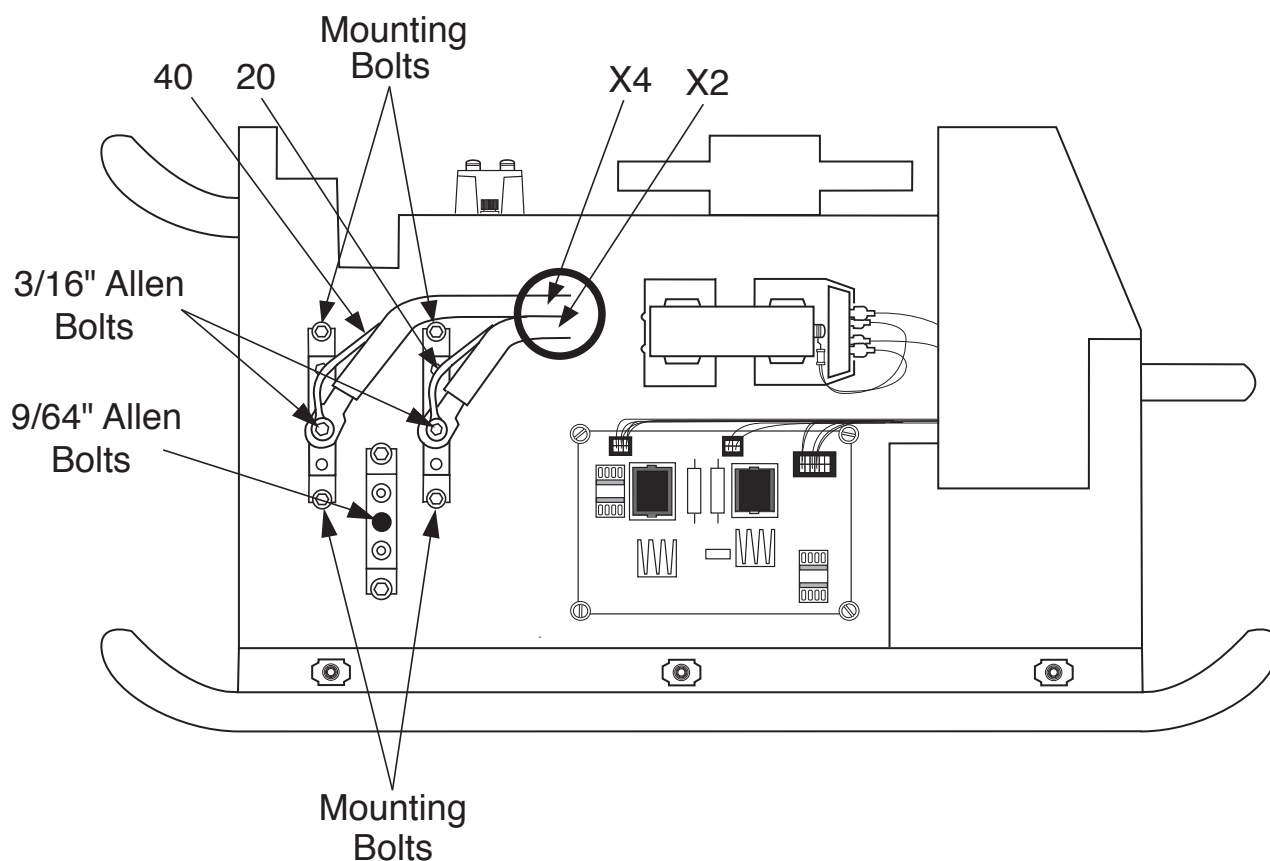

NOTES

Return to Section TOC
Return to Master TOC

Return to Section TOC
Return to Master TOC

Return to Section TOC
Return to Master TOC

Return to Section TOC
Return to Master TOC

POWER WAVE® 355/405



TROUBLESHOOTING & REPAIR

CURRENT TRANSDUCER REMOVAL AND REPLACEMENT



WARNING

Service and repair should be performed by only Lincoln Electric factory trained personnel. Unauthorized repairs performed on this equipment may result in danger to the technician or machine operator and will invalidate your factory warranty. For your safety and to avoid electrical shock, please observe all safety notes and precautions detailed throughout this manual.

If for any reason you do not understand the test procedures or are unable to perform the test/repairs safely, contact the Lincoln Electric Service Department for electrical troubleshooting assistance before you proceed. Call 1-888-935-3877.

DESCRIPTION

The following procedure will aid the technician in removing the current transducer for maintenance or replacement.

MATERIALS NEEDED

- 5/16" Nut Driver
- 1/4" Nut Driver
- 1/2" Nut Driver
- 3/8" Nut Driver
- Channel Locks
- Flathead Screwdriver
- Phillips Head Screwdriver
- Hammer
- Crescent Wrench
- Pliers

TROUBLESHOOTING & REPAIR

CURRENT TRANSDUCER REMOVAL AND REPLACEMENT *(continued)*

PROCEDURE

1. Remove input power to the POWER WAVE® 355/405.
2. Using a 5/16" nut driver remove the case wrap-around cover.
3. Perform the ***Input Filter Capacitor Discharge Procedure*** detailed earlier in this section.
4. Using a 5/16" nut driver remove the four screws from the bottom and right side of the rear assembly. See Figure F.35.

FIGURE F.35 – CASE BACK SCREW LOCATIONS

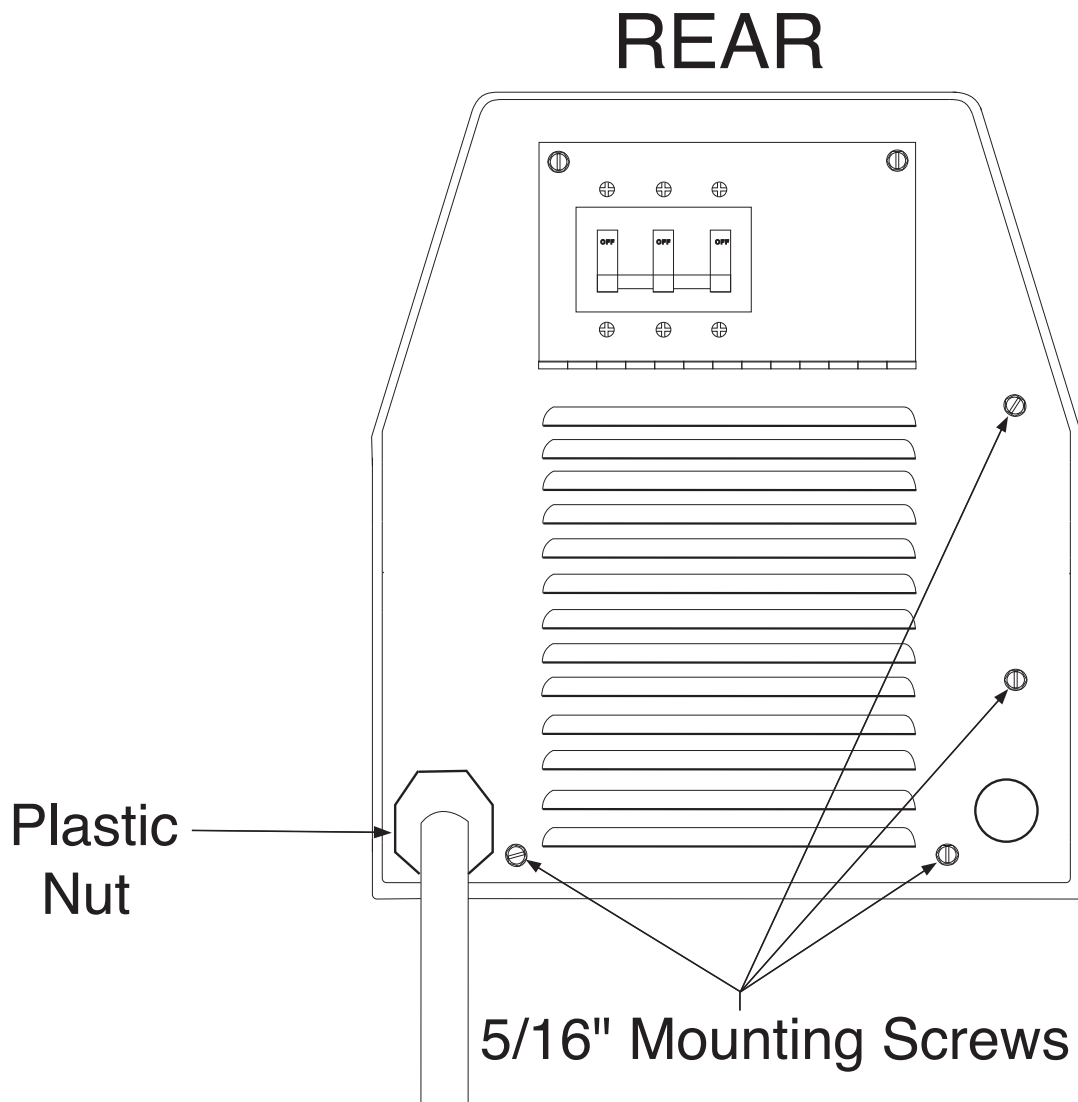

POWER WAVE® 355/405



TROUBLESHOOTING & REPAIR

CURRENT TRANSDUCER REMOVAL AND REPLACEMENT *(continued)*

5. Label and remove the four leads connected to the reconnect panel. Pliers may be necessary.
6. Label and remove the two leads connected to the CB2 circuit breaker.
7. Using a crescent wrench, remove the large plastic nut from around the input power line located at bottom of the rear assembly. See Figure F.36.
8. Locate the steel nut located directly on the other side of the rear assembly behind the plastic nut that was previously removed. See Figure F.36.
9. Using a hammer and a flathead screwdriver, firmly tap the metal nut from the bottom of one of its ribs. This tapping will loosen the nut.
NOTE: Be sure to tap from the bottom so the nut loosens in a counter clockwise fashion if viewed from the front of the machine.
10. Using a 3/8" nut driver label and remove leads #202, #203, #206, #207A from the reconnect switches. See Figure F.36.

FIGURE F.36 LEAD LOCATIONS

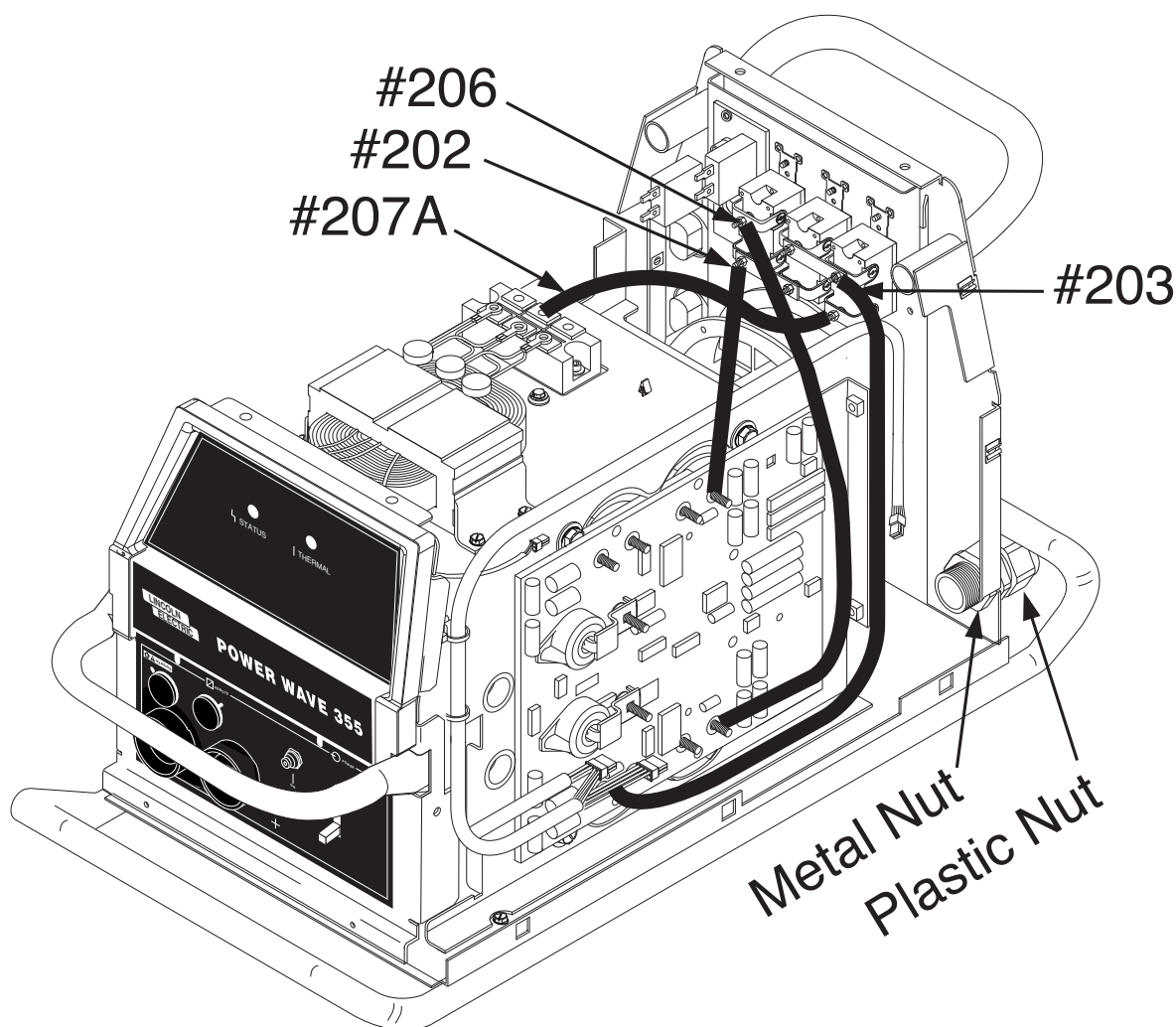

POWER WAVE® 355/405

LINCOLN
ELECTRIC

TROUBLESHOOTING & REPAIR

CURRENT TRANSDUCER REMOVAL AND REPLACEMENT *(continued)*

11. The back of the machine may now gently be pulled away to gain access to the current transducer. Note: The rear of the machine cannot be removed completely.
12. Carefully swing the rear of the machine open to the left while facing the rear of the machine.
13. Perform the **Snubber Board Removal Procedure**.
14. Remove leads #X2 and #20 from the output diode module.
15. Remove leads #X4 and #40 from the other output diode module.
16. Using a 3/8" wrench, remove the three mounting screws from the output diode heatsink assembly. Take note placement of insulation for reassembly. See Figure F.37.
17. Cut any necessary cable ties and carefully remove the heavy lead from the diode heatsink using a 1/2" nut driver.
18. Remove the output diode heatsink assembly through the rear of the machine.
19. Remove plug #J90 from the current transducer.
20. Using a 3/8" nut driver, remove the two mounting nuts from the current transducer.

FIGURE F.37 – OUTPUT HEATSINK MOUNTING SCREW LOCATION

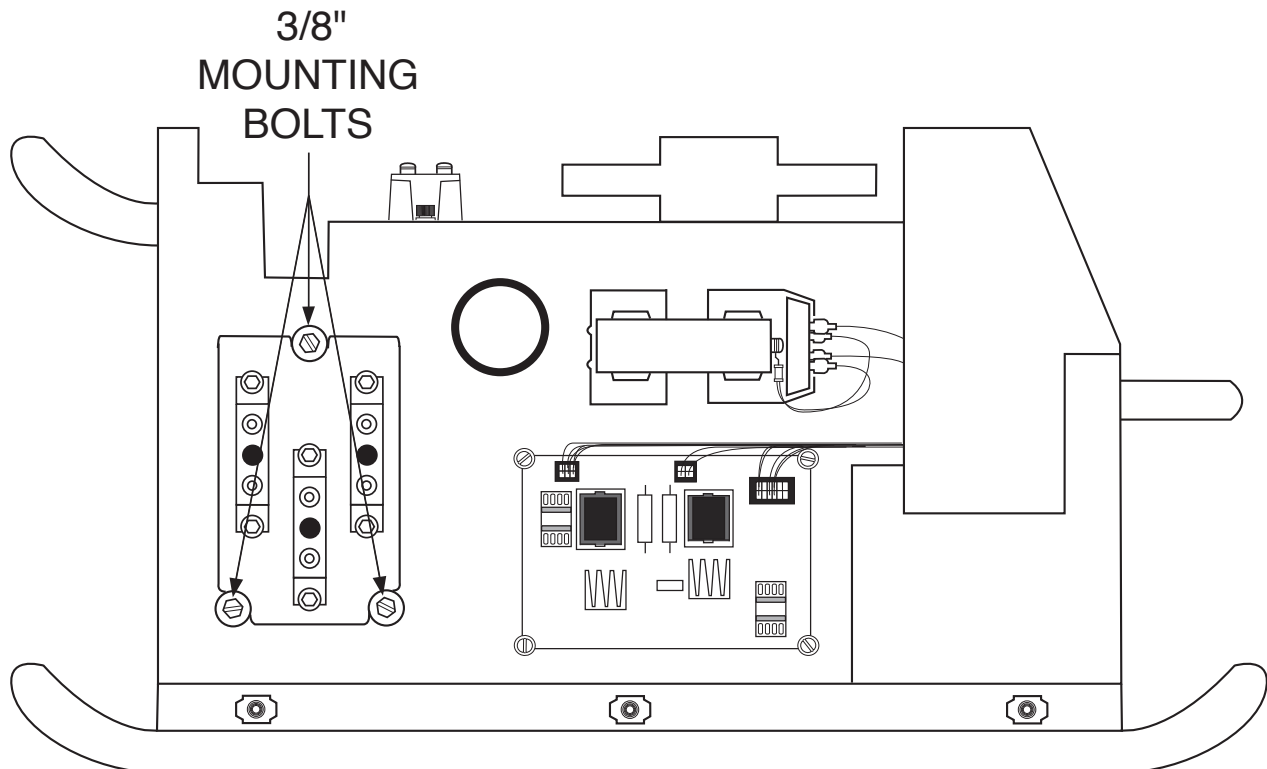

TROUBLESHOOTING & REPAIR

CURRENT TRANSDUCER REMOVAL AND REPLACEMENT (*continued*)

- | | |
|---|--|
| <p>21. Replace the current transducer.</p> <p>22. Replace the two 3/8" mounting nuts previously removed.</p> <p>23. Reconnect plug #J90 to the current transducer.</p> <p>24. Replace any necessary cable ties previously cut.</p> <p>25. From the rear of the machine, replace the heavy flex lead to the bottom of the output diode heatsink assembly using a 1/2" wrench. Note: Don't forget to include all washers.</p> <p>26. Replace the output diode heatsink assembly previously removed using a 3/8" wrench.</p> <p>Note: Be sure to place insulation in its original location.</p> <p>27. Replace leads X2, #20, X4, #40 previously removed from the two output diode modules. Torque to 30-40 inch lbs.</p> <p>28. Perform the <i>Snubber Board Replacement Procedure</i>.</p> | <p>29. The rear of the machine may now be placed back into its original position.</p> <p>30. Using a 3/8" wrench, replace leads #202, #203, #206, and #207A previously removed from the reconnect switches.</p> <p>31. Tighten the metal nut previously removed from the inside of the rear wall on the back of the machine. Channel locks may be necessary.</p> <p>32. Replace the large plastic nut from around input power line located at the back of the machine.</p> <p>33. Replace the four leads to the reconnect panel in their proper locations.</p> <p>34. Replace the two CB2 circuit breaker leads previously removed.</p> <p>35. Using a 5/16" nut driver, replace the four screws from the rear assembly.</p> <p>36. Replace the case wraparound cover.</p> |
|---|--|

RETEST AFTER REPAIR

Retest a machine:

If it is rejected under test for any reason that requires you to remove any part which could affect the machine's electrical characteristics.

OR

If you repair or replace any electrical components.

INPUT IDLE AMPS AND WATTS

Input Volts/Hertz	Maximum Idle Amps	Maximum Idle KW
208/60	4.0	0.45
230/60	3.3	0.45
400/60	2.1	0.45
460/60	2.0	0.45
575/60	1.8	0.45

MAXIMUM OUTPUT VOLTAGES

Input Volts/Hertz	Output Terminals - No load	X1 - X2	115 Volt Receptacles	
208/60 230/60 400/60 460/60 575/60	50-70 VDC	48.5 - 55 VDC	OCV 115 - 123 VAC	10 Amp Load 111 - 119 VAC

TABLE OF CONTENTS -ELECTRICAL DIAGRAMS SECTION-

ELECTRICAL DIAGRAMS	SECTION G
WIRING DIAGRAM - BELOW CODE 11400 - (G4131)	G-2
WIRING DIAGRAM - ABOVE CODE 11400 - (G4131-1)	G-3
ENTIRE MACHINE SCHEMATIC (G4132)	G-4
CONTROL PC BOARD SCHEMATIC #1 (G3789-1D0/1)	G-5
CONTROL PC BOARD SCHEMATIC #2 (G3789-1D0/2)	G-6
CONTROL PC BOARD SCHEMATIC #3 (G3789-1D0/3)	G-7
CONTROL PC BOARD SCHEMATIC #4 (G3789-1D0/4)	G-8
CONTROL PC BOARD ASSEMBLY (S25385-[]for 355, S25425-[] for 405).....	*
DIGITAL POWER SUPPLY PC BOARD SCHEMATIC (G3631)	G-9
DIGITAL POWER SUPPLY PC BOARD ASSEMBLY (G3632-[])	*
SWITCH PC BOARD SCHEMATIC (L11487)	G-10
SWITCH PC BOARD ASSEMBLY (G3830-[])	G-11
SNUBBER PC BOARD SCHEMATIC (S24761)	G-12
SNUBBER PC BOARD ASSEMBLY (M19532-[])	G-13
40 VDC BUSS PC BOARD SCHEMATIC (M19330)	G-14
40 VDC BUSS PC BOARD ASSEMBLY (L11832-[])	*

* NOTE: Many PC Board Assemblies are now totally encapsulated and are therefore considered to be unserviceable. The Assembly numbers are provided on this page but the actual drawings are no longer included.

WIRING DIAGRAM - POWERWAVE 355/405 - BELOW CODE 11400 - G4131

WIRING DIAGRAM - POWER WAVE 355/405

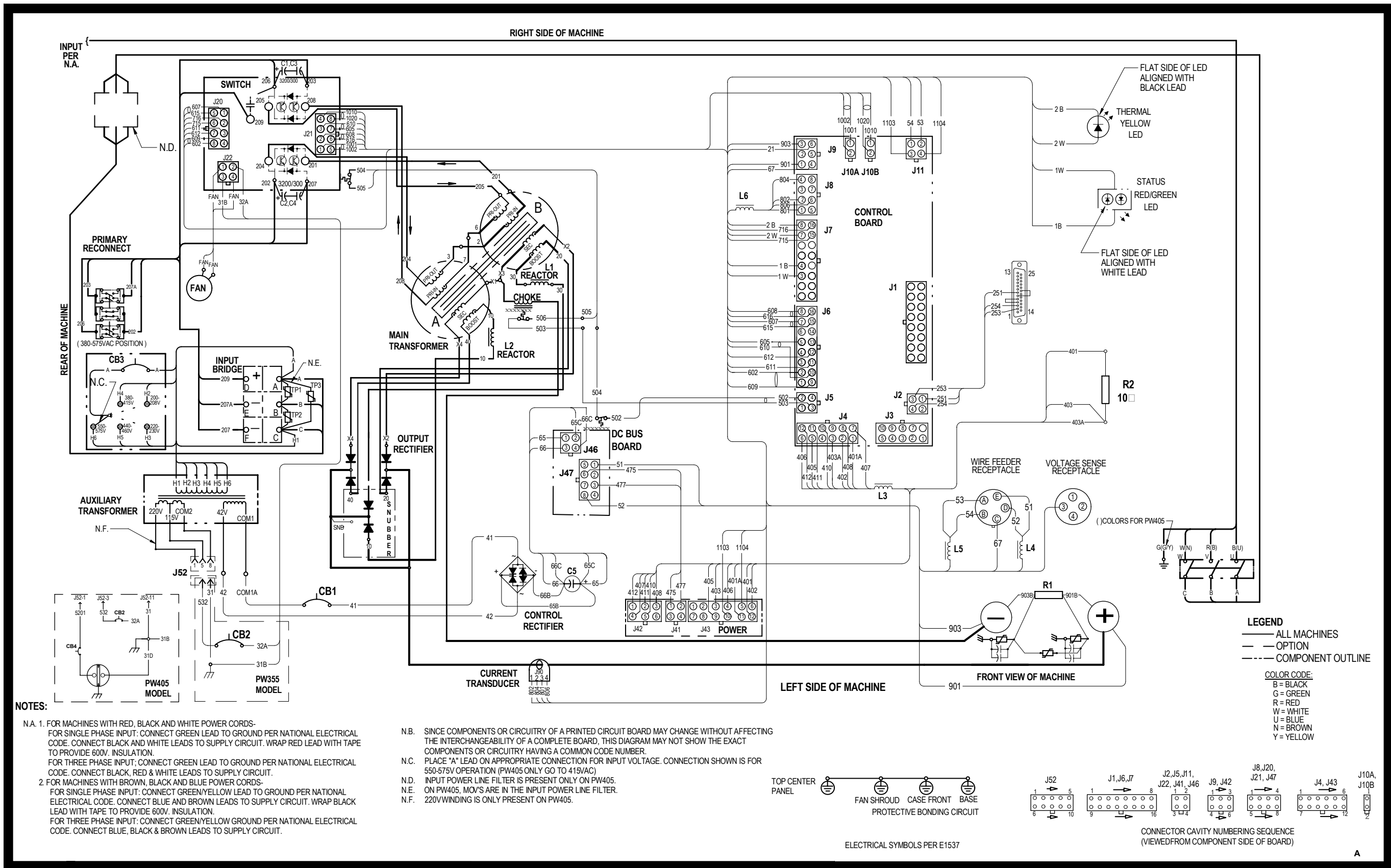

NOTES:

N.A. 1. FOR MACHINES WITH RED, BLACK AND WHITE POWER CORDS-
 FOR SINGLE PHASE INPUT: CONNECT GREEN LEAD TO GROUND PER NATIONAL ELECTRICAL CODE. CONNECT BLACK AND WHITE LEADS TO SUPPLY CIRCUIT. WRAP RED LEAD WITH TAPE TO PROVIDE 600V. INSULATION.
 FOR THREE PHASE INPUT: CONNECT GREEN LEAD TO GROUND PER NATIONAL ELECTRICAL CODE. CONNECT BLACK, RED & WHITE LEADS TO SUPPLY CIRCUIT. WRAP BLACK LEAD WITH TAPE TO PROVIDE 600V. INSULATION.

2. FOR MACHINES WITH BROWN, BLACK AND BLUE POWER CORDS-
 FOR SINGLE PHASE INPUT: CONNECT GREEN/YELLOW LEAD TO GROUND PER NATIONAL ELECTRICAL CODE. CONNECT BLUE AND BROWN LEADS TO SUPPLY CIRCUIT. WRAP BLACK LEAD WITH TAPE TO PROVIDE 600V. INSULATION.
 FOR THREE PHASE INPUT: CONNECT GREEN/YELLOW GROUND PER NATIONAL ELECTRICAL CODE. CONNECT BLUE, BLACK & BROWN LEADS TO SUPPLY CIRCUIT.

N.B. SINCE COMPONENTS OR CIRCUITRY OF A PRINTED CIRCUIT BOARD MAY CHANGE WITHOUT AFFECTING THE INTERCHANGEABILITY OF A COMPLETE BOARD, THIS DIAGRAM MAY NOT SHOW THE EXACT COMPONENTS OR CIRCUITRY HAVING A COMMON CODE NUMBER.

N.C. PLACE "A" LEAD ON APPROPRIATE CONNECTION FOR INPUT VOLTAGE. CONNECTION SHOWN IS FOR 550-575V OPERATION (PW405 ONLY GO TO 415VAC)

N.D. INPUT POWER LINE FILTER IS PRESENT ONLY ON PW405.

N.E. ON PW405, MOV'S ARE IN THE INPUT POWER LINE FILTER.

N.F. 220V WINDING IS ONLY PRESENT ON PW405.

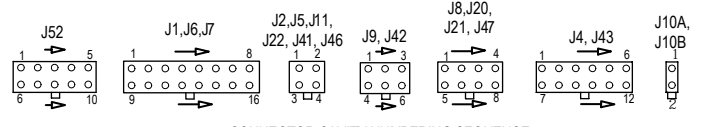

ELECTRICAL SYMBOLS PER E1537

CONNECTOR CAVITY NUMBERING SEQUENCE (VIEWED FROM COMPONENT SIDE OF BOARD)

G4131

NOTE: This diagram is for reference only. It may not be accurate for all machines covered by this manual. The wiring diagram specific to your code is pasted inside one of the enclosure panels of your machine.

Return to Section TOC (repeated vertically on the left margin)

WIRING DIAGRAM - POWER WAVE 355/405

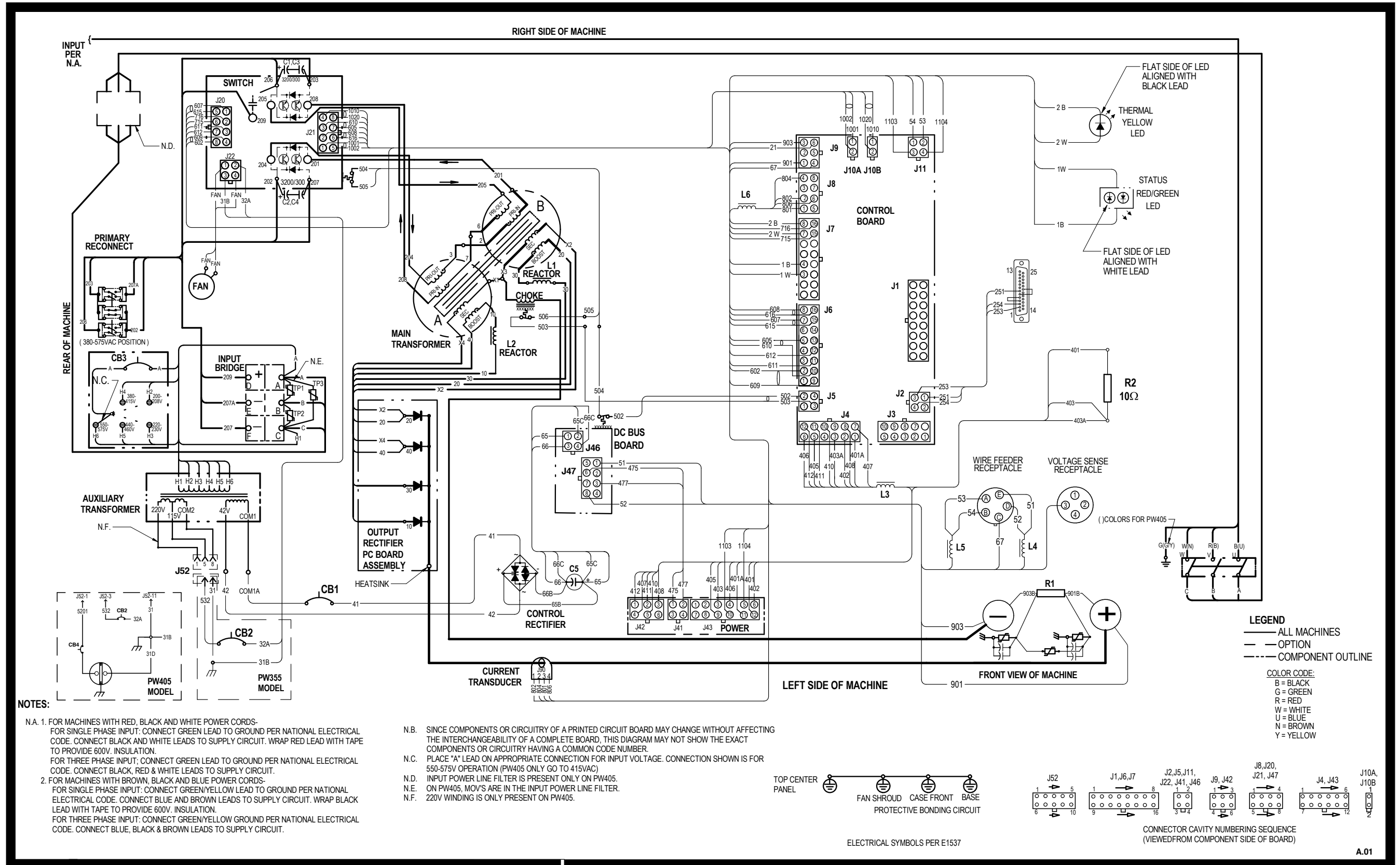

NOTE: This diagram is for reference only. It may not be accurate for all machines covered by this manual. The wiring diagram specific to your code is pasted inside one of the enclosure panels of your machine.

Return to Section TOC

Return to Section TOC

Return to Section TOC

Return to Section TOC

Return to Master TOC

Return to Master TOC

Return to Master TOC

Return to Master TOC

SCHEMATIC - COMPLETE MACHINE

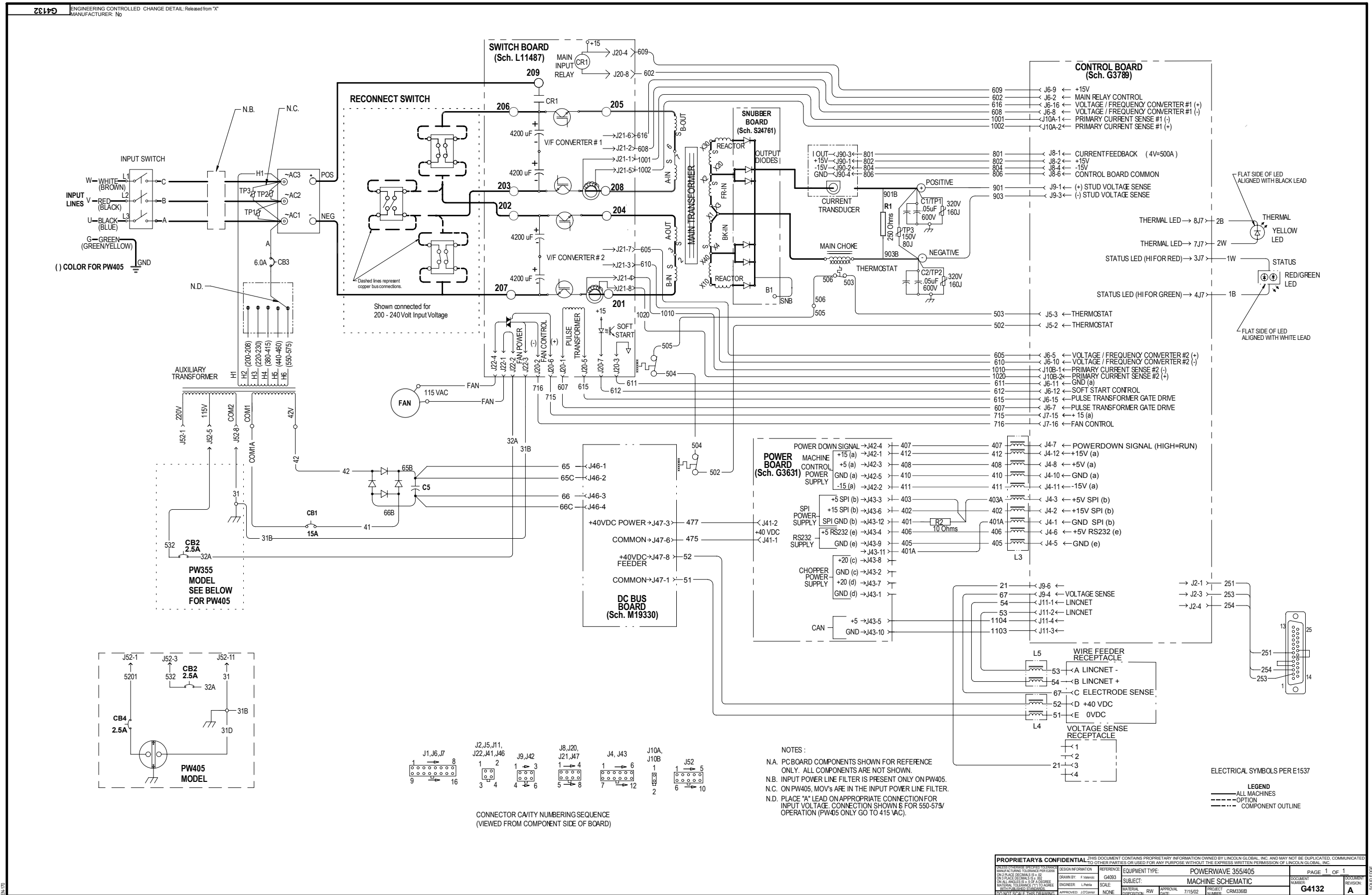

NOTE: This diagram is for reference only. It may not be accurate for all machines covered by this manual.

SCHEMATIC - DIGITAL CONTROL PC BOARD #1

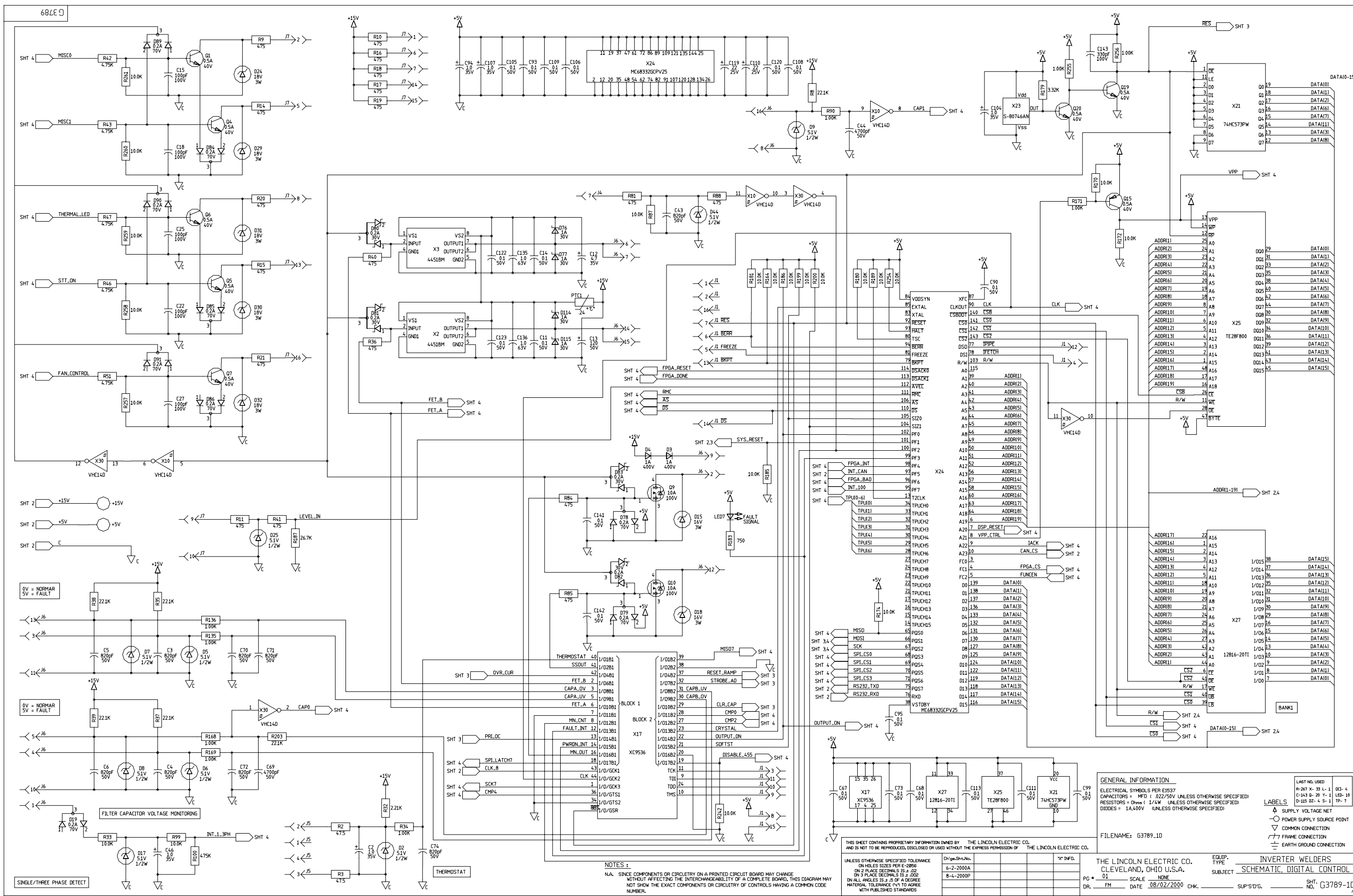

NOTE: This diagram is for reference only. It may not be accurate for all machines covered by this manual.



Return to Section TOC

Return to Master TOC

SCHEMATIC - DIGITAL CONTROL PC BOARD #2

Return to Section TOC
Return to Master TOC

Return to Section TOC
Return to Master TOC

Return to Section TOC
Return to Master TOC

Return to Section TOC
Return to Master TOC

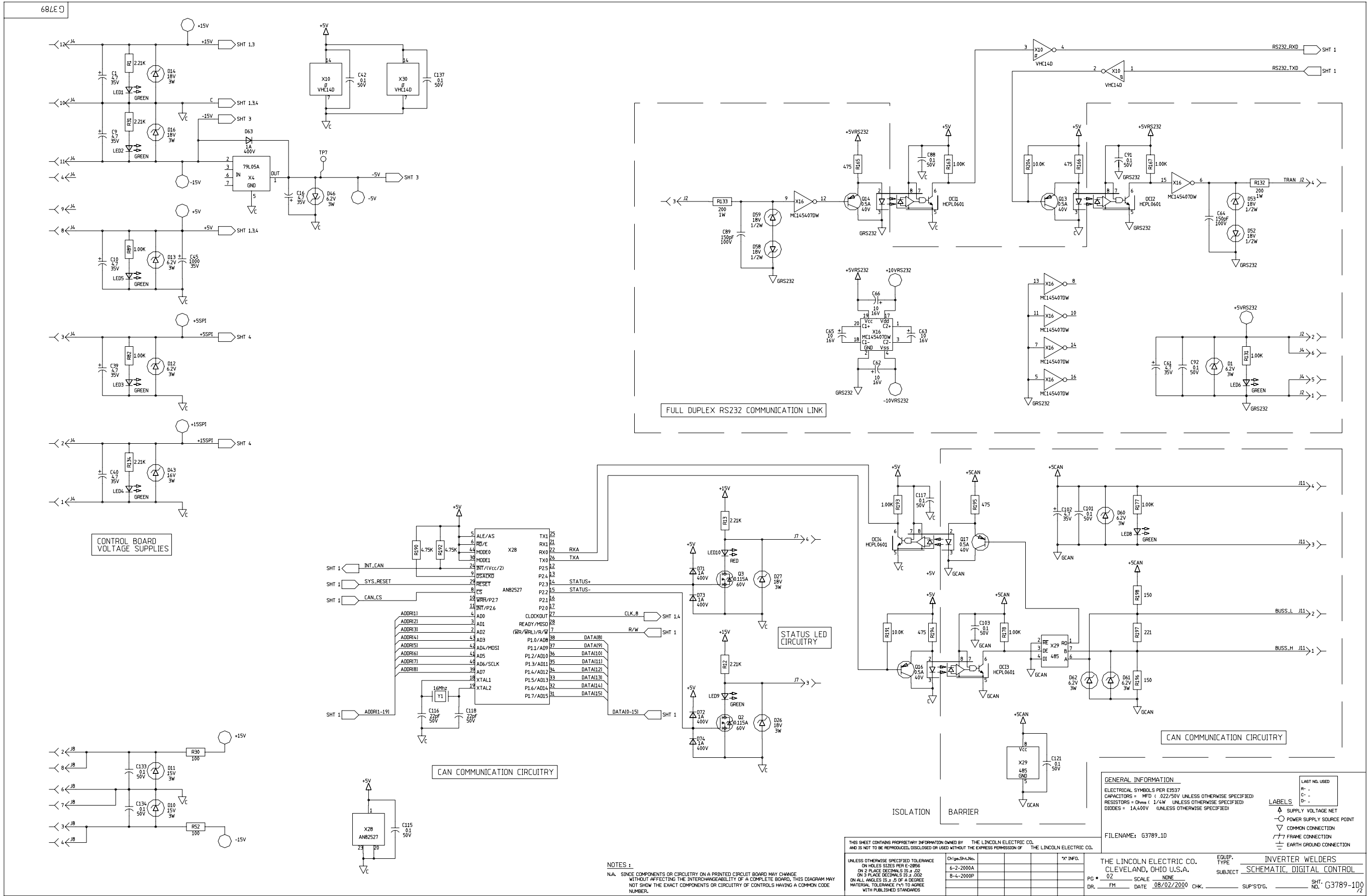

NOTE: This diagram is for reference only. It may not be accurate for all machines covered by this manual.

SCHEMATIC - DIGITAL CONTROL PC BOARD #3

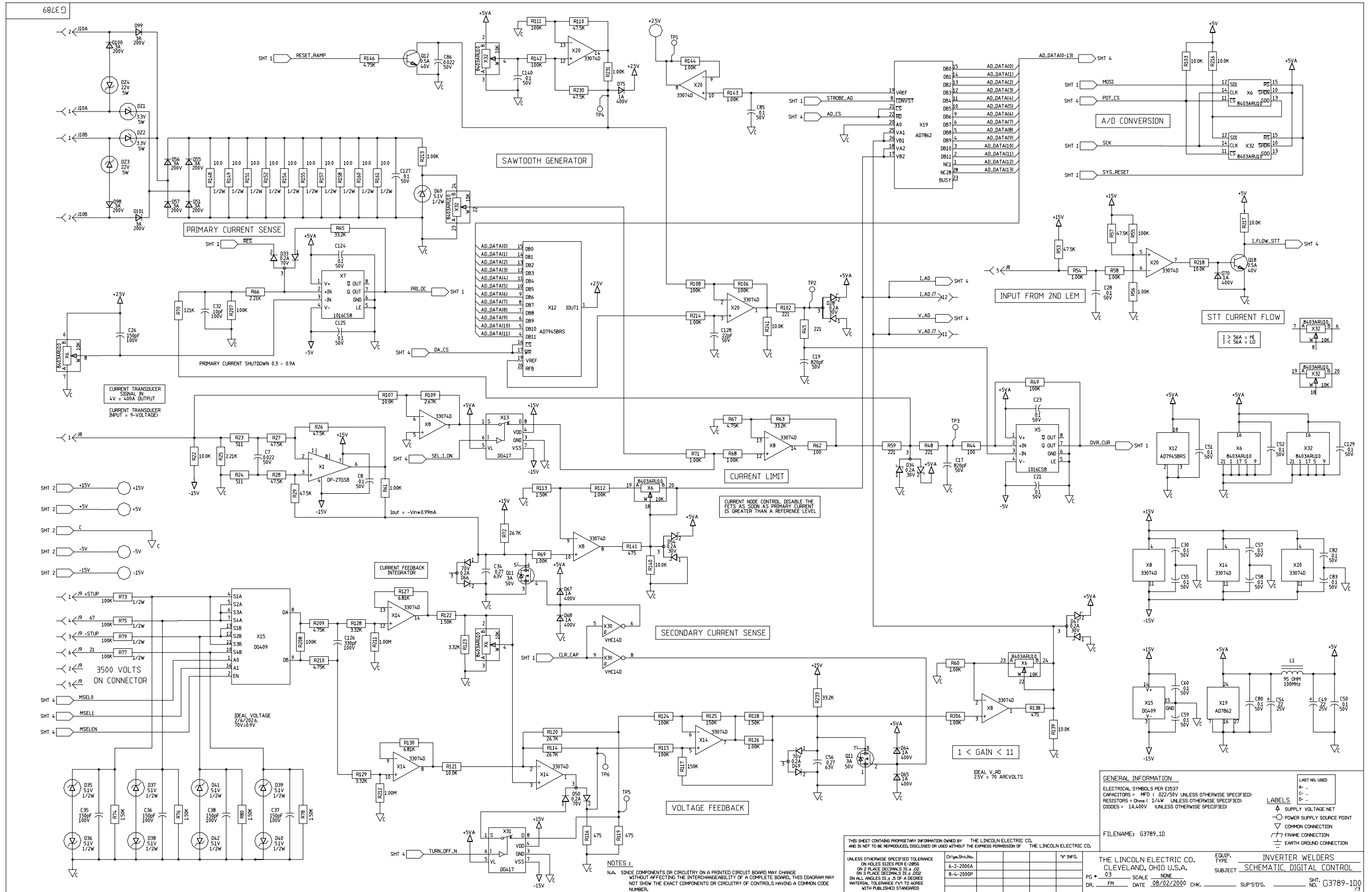

NOTE: This diagram is for reference only. It may not be accurate for all machines covered by this manual.



Return to Section TOC

Return to Master TOC

Return to Section TOC

Return to Master TOC

Return to Section TOC

Return to Master TOC

Return to Section TOC

Return to Master TOC

Return to Section TOC

Return to Master TOC

Return to Section TOC

Return to Master TOC

Return to Section TOC

Return to Master TOC

Return to Section TOC

Return to Master TOC

Return to Section TOC

Return to Master TOC

Return to Section TOC

Return to Master TOC

Return to Section TOC

Return to Master TOC

Return to Section TOC

Return to Master TOC

Return to Section TOC

Return to Master TOC

Return to Section TOC

Return to Master TOC

Return to Section TOC

Return to Master TOC

Return to Section TOC

Return to Master TOC

Return to Section TOC

Return to Master TOC

Return to Section TOC

Return to Master TOC

Return to Section TOC

Return to Master TOC

Return to Section TOC

Return to Master TOC

Return to Section TOC

Return to Master TOC

Return to Section TOC

Return to Master TOC

Return to Section TOC

Return to Master TOC

Return to Section TOC

Return to Master TOC

Return to Section TOC

Return to Master TOC

SCHEMATIC - DIGITAL CONTROL PC BOARD #4

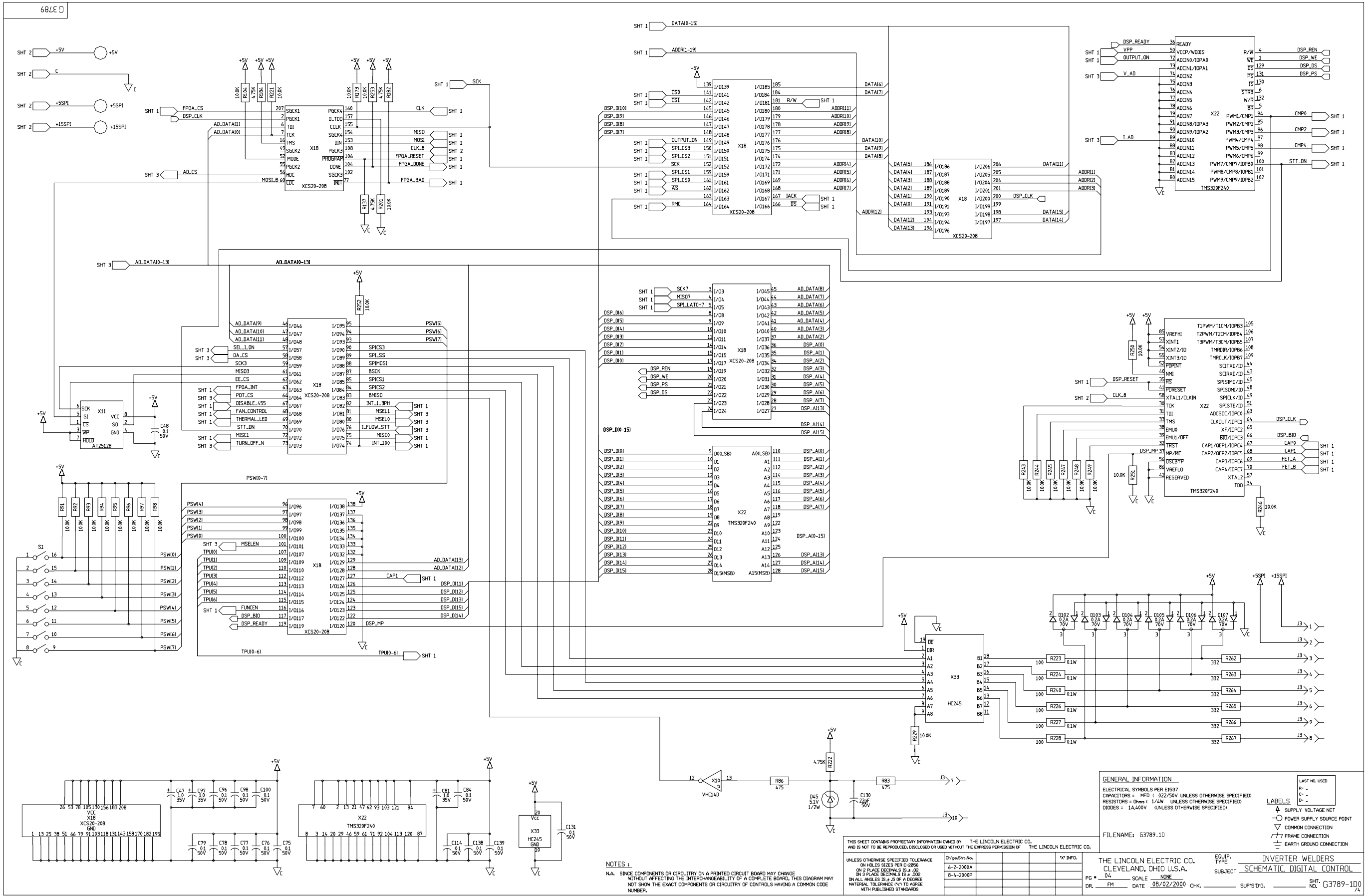

GENERAL INFORMATION
 ELECTRICAL SYMBOLS PER E1537
 CAPACITORS = MFD (.022/50V UNLESS OTHERWISE SPECIFIED)
 RESISTORS = Ohms (1/4W UNLESS OTHERWISE SPECIFIED)
 DIODES = 1A,400V (UNLESS OTHERWISE SPECIFIED)

FILENAME: G3789.10

NOTES:
 N.A. SINCE COMPONENTS OR CIRCUITRY ON A PRINTED CIRCUIT BOARD MAY CHANGE WITHOUT AFFECTING THE INTERCHANGEABILITY OF A COMPLETE BOARD, THIS DIAGRAM MAY NOT SHOW THE EXACT COMPONENTS OR CIRCUITRY OF CONTROLS HAVING A COMMON CODE NUMBER.

UNLESS OTHERWISE SPECIFIED TOLERANCE
 ON HOLES SIZES PER E-2086
 ON 2 PLACE DECIMALS IS ± .02
 ON 3 PLACE DECIMALS IS ± .002
 ON ALL ANGLES IS ± .5 OF A DEGREE
 MATERIAL TOLERANCE TO AGREE WITH PUBLISHED STANDARDS

THE LINCOLN ELECTRIC CO.
 CLEVELAND, OHIO U.S.A.

PG # 04 SCALE NONE
 DR. FM DATE 08/22/2000 CHK. _____

EQUIP. TYPE INVERTER WELDERS
 SUBJECT SCHEMATIC, DIGITAL CONTROL

LAST NO. USED
 A - SUPPLY VOLTAGE NET
 P - POWER SUPPLY SOURCE POINT
 C - COMMON CONNECTION
 F - FRAME CONNECTION
 E - EARTH GROUND CONNECTION

SHT. NO. G3789-100/4

NOTE: This diagram is for reference only. It may not be accurate for all machines covered by this manual.



SCHEMATIC - POWER SUPPLY PRINTED CIRCUIT BOARD

Return to Section TOC
Return to Master TOC

Return to Section TOC
Return to Master TOC

Return to Section TOC
Return to Master TOC

Return to Section TOC
Return to Master TOC

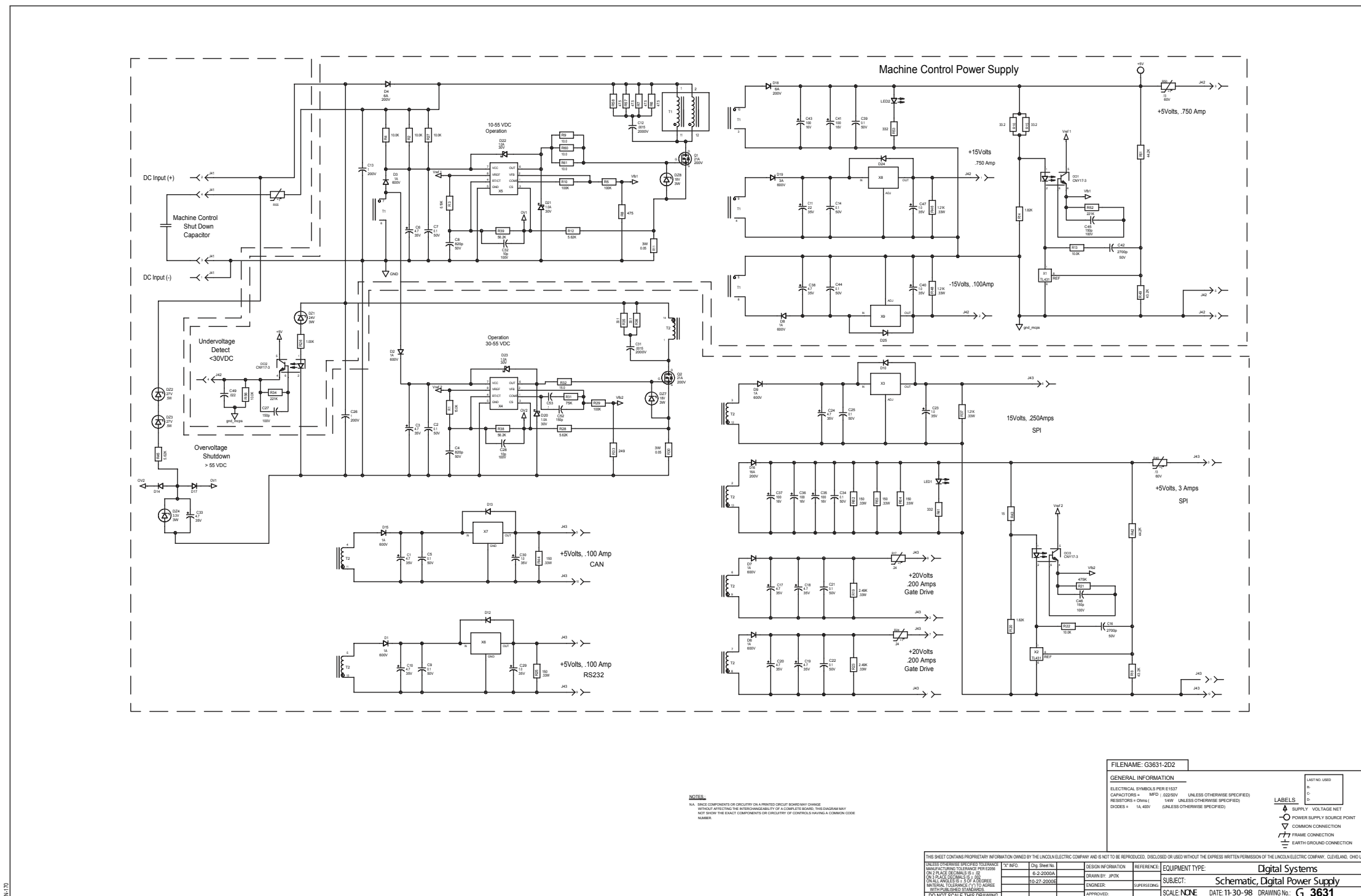

NOTES:
 1. SINCE COMPONENTS OR CIRCUITRY ON A PRINTED CIRCUIT BOARD MAY CHANGE WITHOUT AFFECTING THE INTEROPERABILITY OF A COMPLETE BOARD, THIS DRAWING MAY NOT SHOW THE EXACT COMPONENTS OR CIRCUITRY OF CONTROLS HAVING A COMMON CASE NUMBER.

FILENAME: G3631-2D2

GENERAL INFORMATION

ELECTRICAL SYMBOLS PER #1537
 CAPACITORS = MFD (UNLESS OTHERWISE SPECIFIED)
 RESISTORS = OHMS (UNLESS OTHERWISE SPECIFIED)
 DIODES = 1A, 40V (UNLESS OTHERWISE SPECIFIED)

LIST NO. USED
 A
 B
 C

LABELS
 ▲ SUPPLY VOLTAGE NET
 ○ POWER SUPPLY SOURCE POINT
 ▽ COMMON CONNECTION
 □ FRAME CONNECTION
 ⊕ EARTH GROUND CONNECTION

THIS SHEET CONTAINS PROPRIETARY INFORMATION OWNED BY THE LINCOLN ELECTRIC COMPANY AND IS NOT TO BE REPRODUCED, DISCLOSED OR USED WITHOUT THE EXPRESS WRITTEN PERMISSION OF THE LINCOLN ELECTRIC COMPANY, CLEVELAND, OHIO U.S.A.

DESIGNER	DATE	DESIGN INFORMATION	REFERENCE	EQUIPMENT TYPE
DRW	11-30-98	3631-2D2000A		Digital Systems
CHK		3631-2D2000E		SUBJECT: Schematic, Digital Power Supply
APP				SCALE: NONE DATE: 11-30-98 DRAWING NO.: G 3631

DO NOT SCALE THIS DRAWING

NOTE: This diagram is for reference only. It may not be accurate for all machines covered by this manual.

SCHEMATIC - SWITCH PC BOARD

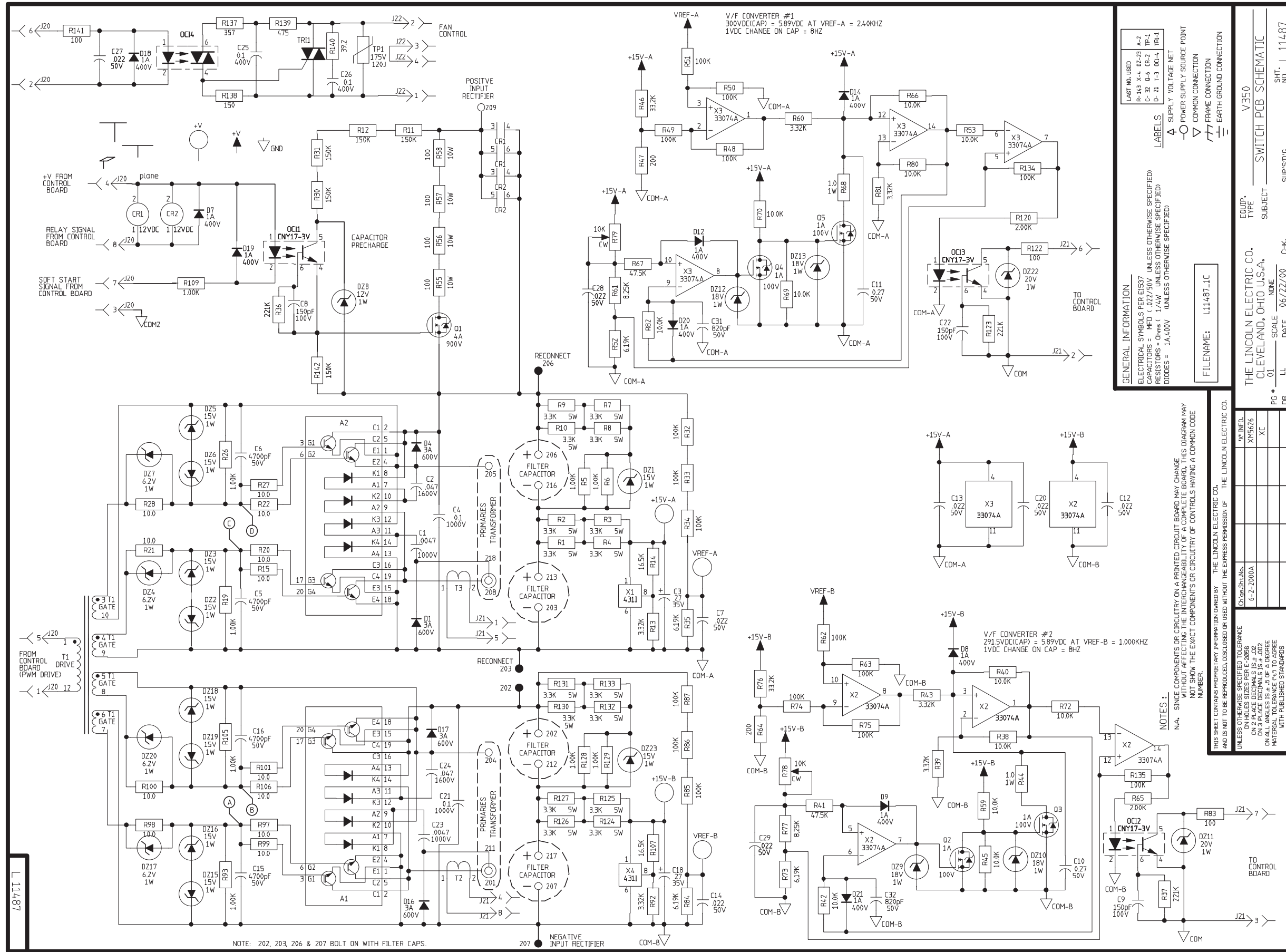

GENERAL INFORMATION

ELECTRICAL SYMBOLS PER E1537
 CAPACITORS = MFD (.022/50V UNLESS OTHERWISE SPECIFIED)
 RESISTORS = Ohms (1/4W UNLESS OTHERWISE SPECIFIED)
 DIODES = 1A/400V (UNLESS OTHERWISE SPECIFIED)

FILENAME: L11487.1C

LAST NO. USED
 R-143 X-4 02-29 A-2
 C-32 B-6 CR-2 TP-1
 D-21 F-3 04-4 TR-1

LABELS
 A SUPPLY VOLTAGE NET
 B POWER SUPPLY SOURCE POINT
 C COMMON CONNECTION
 D FRAME CONNECTION
 E EARTH GROUND CONNECTION

DR. L L **SCALE** NONE **CHK.** L L **DATE** 06/22/00 **SUP'S/DWG.** L 11487

THE LINCOLN ELECTRIC CO.
 CLEVELAND, OHIO U.S.A.
 EQUIP. TYPE: SWITCH PCB SCHEMATIC
 PG # 01

THIS SHEET CONTAINS PROPRIETARY INFORMATION OWNED BY THE LINCOLN ELECTRIC CO. AND IS NOT TO BE REPRODUCED, DISCLOSED OR USED WITHOUT THE EXPRESS PERMISSION OF THE LINCOLN ELECTRIC CO.

UNLESS OTHERWISE SPECIFIED TOLERANCE
 ON HOLES SIZES PER E-2096
 ON DIMENSIONS PER ASME Y14.5-2002
 ON 2 PLACE DECIMALS IS ± .002
 ON ALL ANGLES IS ± .5 OF A DEGREE
 MATERIAL TOLERANCE (±) TO AGREE WITH PUBLISHED STANDARDS

DR.	L L
DATE	06/22/00
SCALE	NONE
PAGE	01
SUBJECT	SWITCH PCB SCHEMATIC
EQUIP. TYPE	V350
DR.	L L
NO.	11487



NOTE: 202, 203, 206 & 207 BOLT ON WITH FILTER CAPS.

207 NEGATIVE INPUT RECTIFIER

NOTE: This diagram is for reference only. It may not be accurate for all machines covered by this manual.

Return to Section TOC

Return to Master TOC

SCHEMATIC - SNUBBER PC BOARD

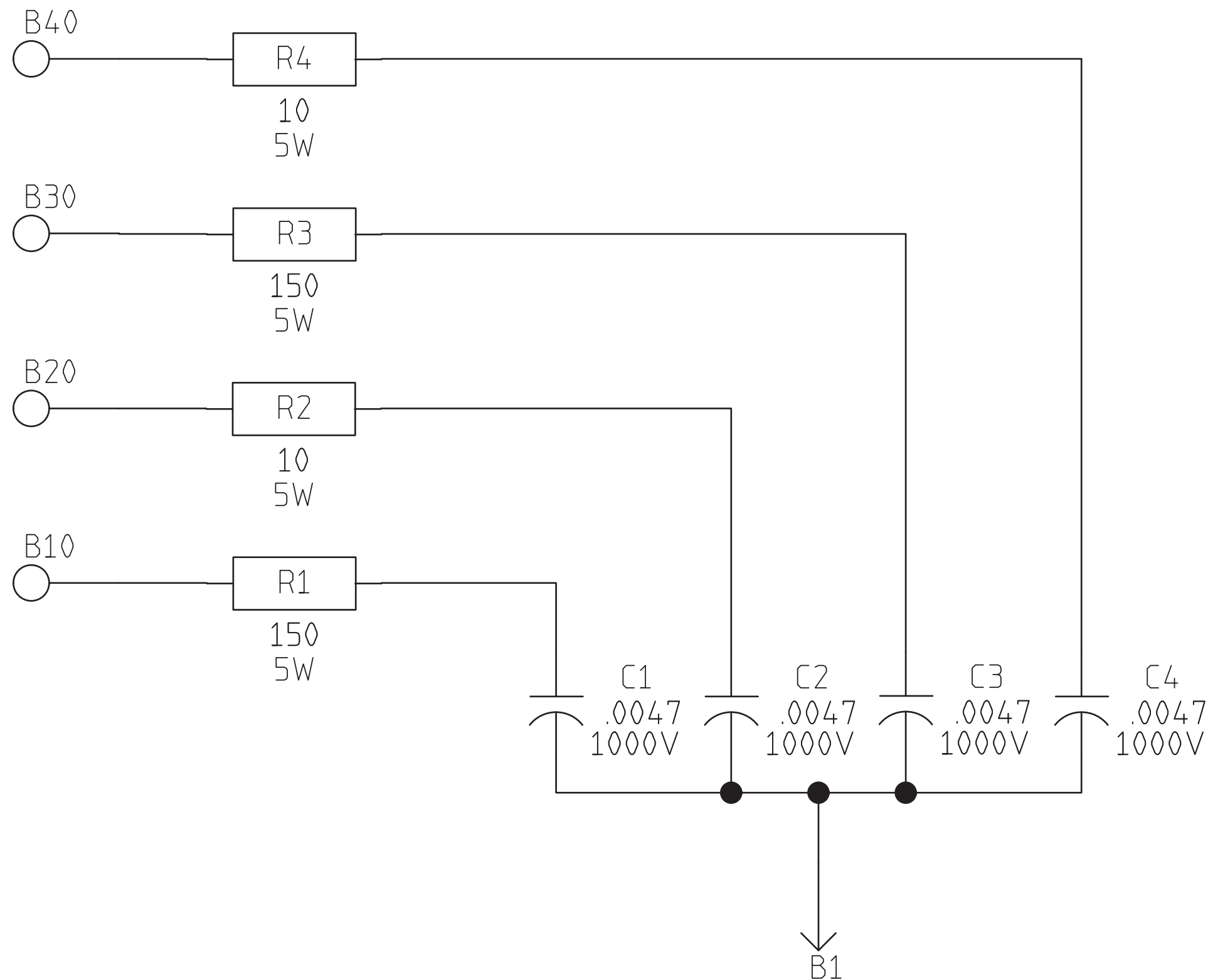

Return to Section TOC
Return to Section TOC
Return to Section TOC
Return to Section TOC
Return to Master TOC
Return to Master TOC
Return to Master TOC
Return to Master TOC

6-2-2000
S24761

NOTE: This diagram is for reference only. It may not be accurate for all machines covered by this manual.

PC BOARD ASSEMBLY - SNUBBER PC BOARD

Return to Section TOC
Return to Master TOC

Return to Section TOC
Return to Master TOC

Return to Section TOC
Return to Master TOC

Return to Section TOC
Return to Master TOC

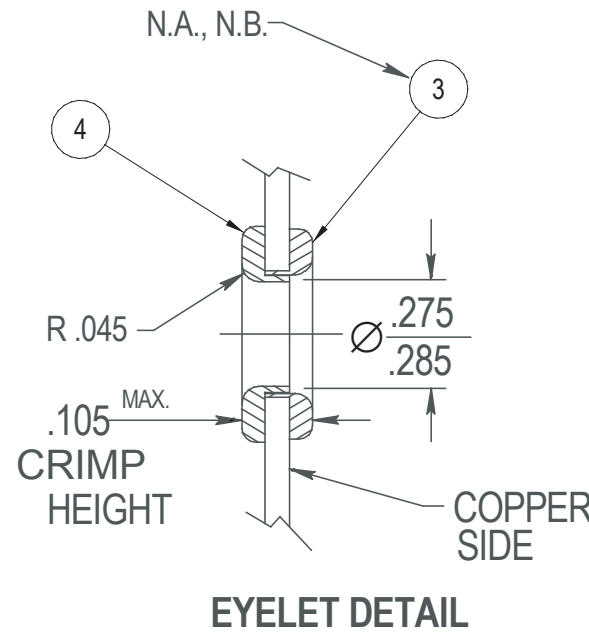
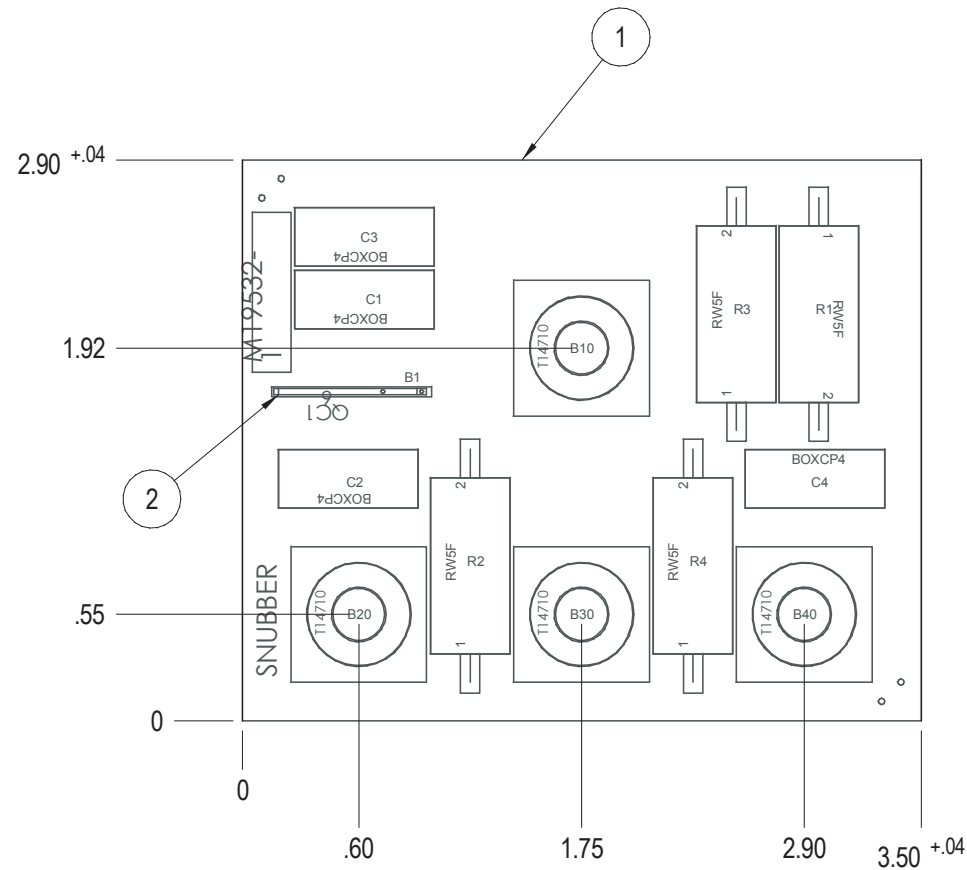

ITEM	REQ'D	PART NO.	DESCRIPTION
C1,C2,C3,C4	4	S20500-4	CAPACITOR,PPMF,.0047,1000V,BOX
R1,R3	2	T14648-20	RESISTOR,WW,5W,150,5%,SQ
R2,R4	2	T14648-25	RESISTOR,WW,5W,10,5%,SQ

ITEM	PART NO.	DESCRIPTION	QTY
1	M19532-A	P.C. BOARD BLANK	1
2	T13157-16	TAB TERMINAL	1
3	T9147-11	EYELET-FEMALE	4
4	T9147-15	EYELET-MALE	4

NOTES:
 N.A. FEMALE EYELET TO BE AGAINST THE COPPER SIDE AS SHOWN
 EYELET MUST NOT SPIN AFTER CLINCHING.
 N.B. SOLDER EYELET SO THAT SOLDER COVERS ENTIRE EYELET
 AND ALL AROUND EYELET ON COPPER SIDE ONLY.
 NO ICICLES OR SOLDER BLOBS PERMITTED.

MANUFACTURED AS:

M19532-1A0

IDENTIFICATION CODE

MAKE PER E1911
 ENCAPSULATE WITH E1844, 2 COATS
 TEST PER E3817-SN

THIS SHEET CONTAINS PROPRIETARY INFORMATION OWNED BY THE LINCOLN ELECTRIC COMPANY AND IS NOT TO BE REPRODUCED, DISCLOSED OR USED WITHOUT THE EXPRESS WRITTEN PERMISSION OF THE LINCOLN ELECTRIC COMPANY, CLEVELAND, OHIO U.S.A.					
UNLESS OTHERWISE SPECIFIED TOLERANCE MANUFACTURING TOLERANCE PER E2056 ON 2 PLACE DECIMALS IS ± .02 ON 3 PLACE DECIMALS IS ± .002 ON ALL ANGLES IS ± .5 OF A DEGREE MATERIAL TOLERANCE ("I") TO AGREE WITH PUBLISHED STANDARDS. DO NOT SCALE THIS DRAWING	Chg. Sheet No.	"X" INFO.	DESIGN INFORMATION	REFERENCE:	EQUIPMENT TYPE: INVERTER DRIVERS
	6-2-2000	XM5626	DRAWN BY: F.V.		SUBJECT: SNUBBER P. BOARD ASSEMBLY
		XC-UF	ENGINEER:	SUPERSEDING:	SCALE: NONE DATE: 10-6-99 DRAWING No.: M 19532-1
			APPROVED:		

SOLID EDGE

NOTE: Lincoln Electric assumes no responsibility for liabilities resulting from board level troubleshooting. PC Board repairs will invalidate your factory warranty. **Individual Printed Circuit Board Components are not available from Lincoln Electric.** This information is provided for reference only. Lincoln Electric discourages board level troubleshooting and repair since it may compromise the quality of the design and may result in danger to the Machine Operator or Technician. Improper PC board repairs could result in damage to the machine.

SCHEMATIC - 40 VDC BUSS PC BOARD

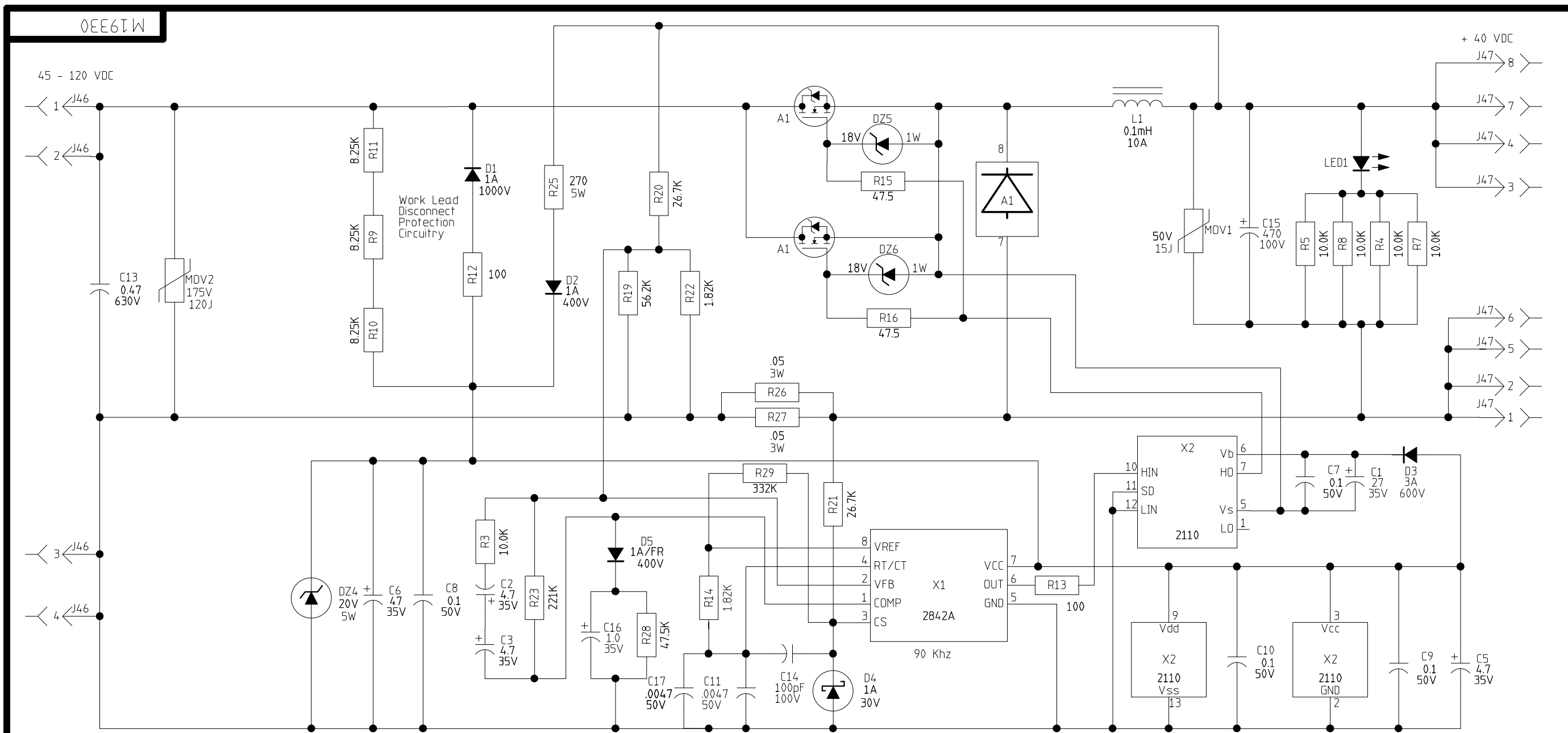

NOTES :

N.A. SINCE COMPONENTS OR CIRCUITRY ON A PRINTED CIRCUIT BOARD MAY CHANGE WITHOUT AFFECTING THE INTERCHANGEABILITY OF A COMPLETE BOARD, THIS DIAGRAM MAY NOT SHOW THE EXACT COMPONENTS OR CIRCUITRY OF CONTROLS HAVING A COMMON CODE NUMBER.

THIS SHEET CONTAINS PROPRIETARY INFORMATION OWNED BY THE LINCOLN ELECTRIC CO. AND IS NOT TO BE REPRODUCED, DISCLOSED OR USED WITHOUT THE EXPRESS PERMISSION OF THE LINCOLN ELECTRIC CO.

UNLESS OTHERWISE SPECIFIED TOLERANCE
 ON HOLES SIZES PER E-2056
 ON 2 PLACE DECIMALS IS ± .02
 ON 3 PLACE DECIMALS IS ± .002
 ON ALL ANGLES IS ± .5 OF A DEGREE
 MATERIAL TOLERANCE ("t") TO AGREE
 WITH PUBLISHED STANDARDS

Ch'ge.Sht.No.				
XC-UF				
9-17-99				

GENERAL INFORMATION

ELECTRICAL SYMBOLS PER E1537
 CAPACITORS = MFD (----- UNLESS OTHERWISE SPECIFIED)
 RESISTORS = Ohms (----- UNLESS OTHERWISE SPECIFIED)
 DIODES = ----- (UNLESS OTHERWISE SPECIFIED)

LAST NO. USED	
R- 29 MOV- 2	X- 2
C- 17 LED- 1	L- 1
D- 5 DZ- 6	A- 1

LABELS

- ▲ SUPPLY VOLTAGE NET
- POWER SUPPLY SOURCE POINT
- ▽ COMMON CONNECTION
- ⎓ FRAME CONNECTION
- ⊥ EARTH GROUND CONNECTION

FILENAME: M19330_1BA

THE LINCOLN ELECTRIC CO.
 CLEVELAND, OHIO U.S.A.

EQUIP. TYPE MULTI-SYSTEMS 40 VDC BUSS
 SUBJECT POWER SUPPLY PCB SCHEMATIC

PG # 01 SCALE NONE
 DR. TEK DATE 09/01/99 CHK. SUP'S'D'G. SHT. NO. M19330

NOTE: This diagram is for reference only. It may not be accurate for all machines covered by this manual.

Return to Section TOC