

SAE400 & SAE400 WELD'N AIR - DC ARC WELDING POWER SOURCE

IM640-A

May, 2004

For use with machines having Code Numbers: 10601, 10602, 10884, 10885



This manual covers equipment which is no longer in production by The Lincoln Electric Co. Specifications and availability of optional features may have changed.

Safety Depends on You

Lincoln arc welding and cutting equipment is designed and built with safety in mind. However, your overall safety can be increased by proper installation ... and thoughtful operation on your part. **DO NOT INSTALL, OPERATE OR REPAIR THIS EQUIPMENT WITHOUT READING THIS MANUAL AND THE SAFETY PRECAUTIONS CONTAINED THROUGHOUT.** And, most importantly, think before you act and be careful.

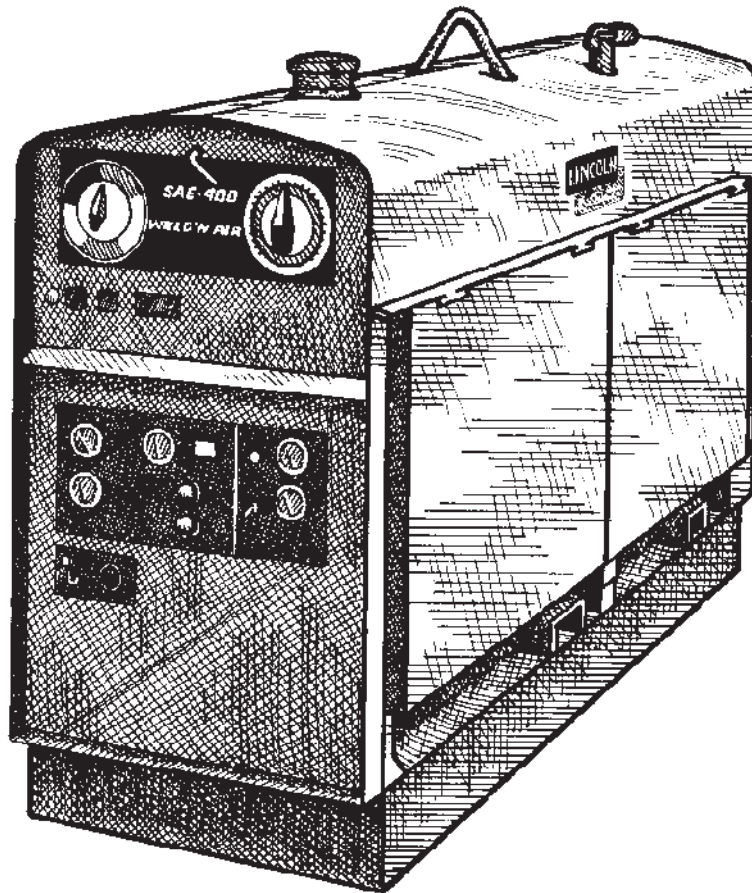

OPERATOR'S MANUAL



LINCOLN[®]
ELECTRIC

Copyright © 2004 Lincoln Global Inc.

- World's Leader in Welding and Cutting Products •
- Sales and Service through Subsidiaries and Distributors Worldwide •

Cleveland, Ohio 44117-1199 U.S.A. TEL: 216.481.8100 FAX: 216.486.1751 WEB SITE: www.lincolnelectric.com

⚠ WARNING

⚠ CALIFORNIA PROPOSITION 65 WARNINGS ⚠

Diesel engine exhaust and some of its constituents are known to the State of California to cause cancer, birth defects, and other reproductive harm.

The Above For Diesel Engines

The engine exhaust from this product contains chemicals known to the State of California to cause cancer, birth defects, or other reproductive harm.

The Above For Gasoline Engines

ARC WELDING CAN BE HAZARDOUS. PROTECT YOURSELF AND OTHERS FROM POSSIBLE SERIOUS INJURY OR DEATH. KEEP CHILDREN AWAY. PACEMAKER WEARERS SHOULD CONSULT WITH THEIR DOCTOR BEFORE OPERATING.

Read and understand the following safety highlights. For additional safety information, it is strongly recommended that you purchase a copy of "Safety in Welding & Cutting - ANSI Standard Z49.1" from the American Welding Society, P.O. Box 351040, Miami, Florida 33135 or CSA Standard W117.2-1974. A Free copy of "Arc Welding Safety" booklet E205 is available from the Lincoln Electric Company, 22801 St. Clair Avenue, Cleveland, Ohio 44117-1199.

BE SURE THAT ALL INSTALLATION, OPERATION, MAINTENANCE AND REPAIR PROCEDURES ARE PERFORMED ONLY BY QUALIFIED INDIVIDUALS.



FOR ENGINE powered equipment.

1.a. Turn the engine off before troubleshooting and maintenance work unless the maintenance work requires it to be running.



1.b. Operate engines in open, well-ventilated areas or vent the engine exhaust fumes outdoors.



1.c. Do not add the fuel near an open flame welding arc or when the engine is running. Stop the engine and allow it to cool before refueling to prevent spilled fuel from vaporizing on contact with hot engine parts and igniting. Do not spill fuel when filling tank. If fuel is spilled, wipe it up and do not start engine until fumes have been eliminated.

1.d. Keep all equipment safety guards, covers and devices in position and in good repair. Keep hands, hair, clothing and tools away from V-belts, gears, fans and all other moving parts when starting, operating or repairing equipment.

1.e. In some cases it may be necessary to remove safety guards to perform required maintenance. Remove guards only when necessary and replace them when the maintenance requiring their removal is complete. Always use the greatest care when working near moving parts.



1.f. Do not put your hands near the engine fan. Do not attempt to override the governor or idler by pushing on the throttle control rods while the engine is running.

1.g. To prevent accidentally starting gasoline engines while turning the engine or welding generator during maintenance work, disconnect the spark plug wires, distributor cap or magneto wire as appropriate.



1.h. To avoid scalding, do not remove the radiator pressure cap when the engine is hot.

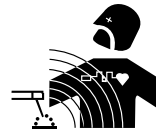

ELECTRIC AND MAGNETIC FIELDS may be dangerous

2.a. Electric current flowing through any conductor causes localized Electric and Magnetic Fields (EMF). Welding current creates EMF fields around welding cables and welding machines

2.b. EMF fields may interfere with some pacemakers, and welders having a pacemaker should consult their physician before welding.

2.c. Exposure to EMF fields in welding may have other health effects which are now not known.

2.d. All welders should use the following procedures in order to minimize exposure to EMF fields from the welding circuit:

2.d.1. Route the electrode and work cables together - Secure them with tape when possible.

2.d.2. Never coil the electrode lead around your body.

2.d.3. Do not place your body between the electrode and work cables. If the electrode cable is on your right side, the work cable should also be on your right side.

2.d.4. Connect the work cable to the workpiece as close as possible to the area being welded.

2.d.5. Do not work next to welding power source.

Mar '95



ELECTRIC SHOCK can kill.

3.a. The electrode and work (or ground) circuits are electrically “hot” when the welder is on. Do not touch these “hot” parts with your bare skin or wet clothing. Wear dry, hole-free gloves to insulate hands.

3.b. Insulate yourself from work and ground using dry insulation. Make certain the insulation is large enough to cover your full area of physical contact with work and ground.

In addition to the normal safety precautions, if welding must be performed under electrically hazardous conditions (in damp locations or while wearing wet clothing; on metal structures such as floors, gratings or scaffolds; when in cramped positions such as sitting, kneeling or lying, if there is a high risk of unavoidable or accidental contact with the workpiece or ground) use the following equipment:

- Semiautomatic DC Constant Voltage (Wire) Welder.
- DC Manual (Stick) Welder.
- AC Welder with Reduced Voltage Control.

3.c. In semiautomatic or automatic wire welding, the electrode, electrode reel, welding head, nozzle or semiautomatic welding gun are also electrically “hot”.

3.d. Always be sure the work cable makes a good electrical connection with the metal being welded. The connection should be as close as possible to the area being welded.

3.e. Ground the work or metal to be welded to a good electrical (earth) ground.

3.f. Maintain the electrode holder, work clamp, welding cable and welding machine in good, safe operating condition. Replace damaged insulation.

3.g. Never dip the electrode in water for cooling.

3.h. Never simultaneously touch electrically “hot” parts of electrode holders connected to two welders because voltage between the two can be the total of the open circuit voltage of both welders.

3.i. When working above floor level, use a safety belt to protect yourself from a fall should you get a shock.

3.j. Also see Items 6.c. and 8.



ARC RAYS can burn.

4.a. Use a shield with the proper filter and cover plates to protect your eyes from sparks and the rays of the arc when welding or observing open arc welding. Headshield and filter lens should conform to ANSI Z87.1 standards.

4.b. Use suitable clothing made from durable flame-resistant material to protect your skin and that of your helpers from the arc rays.

4.c. Protect other nearby personnel with suitable, non-flammable screening and/or warn them not to watch the arc nor expose themselves to the arc rays or to hot spatter or metal.



FUMES AND GASES can be dangerous.

5.a. Welding may produce fumes and gases hazardous to health. Avoid breathing these fumes and gases. When welding, keep your head out of the fume. Use enough ventilation and/or exhaust at the arc to keep fumes and gases away from the breathing zone. **When welding with electrodes which require special ventilation such as stainless or hard facing (see instructions on container or MSDS) or on lead or cadmium plated steel and other metals or coatings which produce highly toxic fumes, keep exposure as low as possible and below Threshold Limit Values (TLV) using local exhaust or mechanical ventilation. In confined spaces or in some circumstances, outdoors, a respirator may be required. Additional precautions are also required when welding on galvanized steel.**

5.b. Do not weld in locations near chlorinated hydrocarbon vapors coming from degreasing, cleaning or spraying operations. The heat and rays of the arc can react with solvent vapors to form phosgene, a highly toxic gas, and other irritating products.

5.c. Shielding gases used for arc welding can displace air and cause injury or death. Always use enough ventilation, especially in confined areas, to insure breathing air is safe.

5.d. Read and understand the manufacturer’s instructions for this equipment and the consumables to be used, including the material safety data sheet (MSDS) and follow your employer’s safety practices. MSDS forms are available from your welding distributor or from the manufacturer.

5.e. Also see item 1.b.

Mar '95

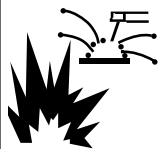

WELDING SPARKS can cause fire or explosion.

6.a. Remove fire hazards from the welding area.

If this is not possible, cover them to prevent the welding sparks from starting a fire.

Remember that welding sparks and hot materials from welding can easily go through small cracks and openings to adjacent areas. Avoid welding near hydraulic lines. Have a fire extinguisher readily available.

6.b. Where compressed gases are to be used at the job site, special precautions should be used to prevent hazardous situations. Refer to "Safety in Welding and Cutting" (ANSI Standard Z49.1) and the operating information for the equipment being used.

6.c. When not welding, make certain no part of the electrode circuit is touching the work or ground. Accidental contact can cause overheating and create a fire hazard.

6.d. Do not heat, cut or weld tanks, drums or containers until the proper steps have been taken to insure that such procedures will not cause flammable or toxic vapors from substances inside. They can cause an explosion even though they have been "cleaned". For information, purchase "Recommended Safe Practices for the Preparation for Welding and Cutting of Containers and Piping That Have Held Hazardous Substances", AWS F4.1 from the American Welding Society (see address above).

6.e. Vent hollow castings or containers before heating, cutting or welding. They may explode.

6.f. Sparks and spatter are thrown from the welding arc. Wear oil free protective garments such as leather gloves, heavy shirt, cuffless trousers, high shoes and a cap over your hair. Wear ear plugs when welding out of position or in confined places. Always wear safety glasses with side shields when in a welding area.

6.g. Connect the work cable to the work as close to the welding area as practical. Work cables connected to the building framework or other locations away from the welding area increase the possibility of the welding current passing through lifting chains, crane cables or other alternate circuits. This can create fire hazards or overheat lifting chains or cables until they fail.

6.h. Also see item 1.c.



CYLINDER may explode if damaged.

7.a. Use only compressed gas cylinders containing the correct shielding gas for the process used and properly operating regulators designed for the gas and pressure used. All hoses, fittings, etc. should be suitable for the application and maintained in good condition.

7.b. Always keep cylinders in an upright position securely chained to an undercarriage or fixed support.

7.c. Cylinders should be located:

- Away from areas where they may be struck or subjected to physical damage.

- A safe distance from arc welding or cutting operations and any other source of heat, sparks, or flame.

7.d. Never allow the electrode, electrode holder or any other electrically "hot" parts to touch a cylinder.

7.e. Keep your head and face away from the cylinder valve outlet when opening the cylinder valve.

7.f. Valve protection caps should always be in place and hand tight except when the cylinder is in use or connected for use.

7.g. Read and follow the instructions on compressed gas cylinders, associated equipment, and CGA publication P-1, "Precautions for Safe Handling of Compressed Gases in Cylinders," available from the Compressed Gas Association 1235 Jefferson Davis Highway, Arlington, VA 22202.



FOR ELECTRICALLY powered equipment.

8.a. Turn off input power using the disconnect switch at the fuse box before working on the equipment.

8.b. Install equipment in accordance with the U.S. National Electrical Code, all local codes and the manufacturer's recommendations.

8.c. Ground the equipment in accordance with the U.S. National Electrical Code and the manufacturer's recommendations.

Mar '95

PRÉCAUTIONS DE SÛRETÉ

Pour votre propre protection lire et observer toutes les instructions et les précautions de sûreté spécifiques qui paraissent dans ce manuel aussi bien que les précautions de sûreté générales suivantes:

Sûreté Pour Soudage A L'Arc

1. Protégez-vous contre la secousse électrique:
 - a. Les circuits à l'électrode et à la pièce sont sous tension quand la machine à souder est en marche. Eviter toujours tout contact entre les parties sous tension et la peau nue ou les vêtements mouillés. Porter des gants secs et sans trous pour isoler les mains.
 - b. Faire très attention de bien s'isoler de la masse quand on soude dans des endroits humides, ou sur un plancher métallique ou des grilles métalliques, principalement dans les positions assis ou couché pour lesquelles une grande partie du corps peut être en contact avec la masse.
 - c. Maintenir le porte-électrode, la pince de masse, le câble de soudage et la machine à souder en bon et sûr état de fonctionnement.
 - d. Ne jamais plonger le porte-électrode dans l'eau pour le refroidir.
 - e. Ne jamais toucher simultanément les parties sous tension des porte-électrodes connectés à deux machines à souder parce que la tension entre les deux pinces peut être le total de la tension à vide des deux machines.
 - f. Si on utilise la machine à souder comme une source de courant pour soudage semi-automatique, ces précautions pour le porte-électrode s'appliquent aussi au pistolet de soudage.
2. Dans le cas de travail au dessus du niveau du sol, se protéger contre les chutes dans le cas où on recoit un choc. Ne jamais enrouler le câble-électrode autour de n'importe quelle partie du corps.
3. Un coup d'arc peut être plus sévère qu'un coup de soleil, donc:
 - a. Utiliser un bon masque avec un verre filtrant approprié ainsi qu'un verre blanc afin de se protéger les yeux du rayonnement de l'arc et des projections quand on soude ou quand on regarde l'arc.
 - b. Porter des vêtements convenables afin de protéger la peau de soudeur et des aides contre le rayonnement de l'arc.
 - c. Protéger l'autre personnel travaillant à proximité au soudage à l'aide d'écrans appropriés et non-inflammables.
4. Des gouttes de laitier en fusion sont émises de l'arc de soudage. Se protéger avec des vêtements de protection libres de l'huile, tels que les gants en cuir, chemise épaisse, pantalons sans revers, et chaussures montantes.
5. Toujours porter des lunettes de sécurité dans la zone de soudage. Utiliser des lunettes avec écrans latéraux dans les

zones où l'on pique le laitier.

6. Eloigner les matériaux inflammables ou les recouvrir afin de prévenir tout risque d'incendie dû aux étincelles.
7. Quand on ne soude pas, poser la pince à une endroit isolé de la masse. Un court-circuit accidentel peut provoquer un échauffement et un risque d'incendie.
8. S'assurer que la masse est connectée le plus près possible de la zone de travail qu'il est pratique de le faire. Si on place la masse sur la charpente de la construction ou d'autres endroits éloignés de la zone de travail, on augmente le risque de voir passer le courant de soudage par les chaînes de levage, câbles de grue, ou autres circuits. Cela peut provoquer des risques d'incendie ou d'échauffement des chaînes et des câbles jusqu'à ce qu'ils se rompent.
9. Assurer une ventilation suffisante dans la zone de soudage. Ceci est particulièrement important pour le soudage de tôles galvanisées plombées, ou cadmiées ou tout autre métal qui produit des fumées toxiques.
10. Ne pas souder en présence de vapeurs de chlore provenant d'opérations de dégraissage, nettoyage ou pistelage. La chaleur ou les rayons de l'arc peuvent réagir avec les vapeurs du solvant pour produire du phosgène (gas fortement toxique) ou autres produits irritants.
11. Pour obtenir de plus amples renseignements sur la sûreté, voir le code "Code for safety in welding and cutting" CSA Standard W 117.2-1974.

PRÉCAUTIONS DE SÛRETÉ POUR LES MACHINES À SOUDER À TRANSFORMATEUR ET À REDRESSEUR

1. Relier à la terre le châssis du poste conformément au code de l'électricité et aux recommandations du fabricant. Le dispositif de montage ou la pièce à souder doit être branché à une bonne mise à la terre.
2. Autant que possible, l'installation et l'entretien du poste seront effectués par un électricien qualifié.
3. Avant de faire des travaux à l'intérieur de poste, la débrancher à l'interrupteur à la boîte de fusibles.
4. Garder tous les couvercles et dispositifs de sûreté à leur place.

Mar. '93

⚠ WARNING

Read before operating your compressor!

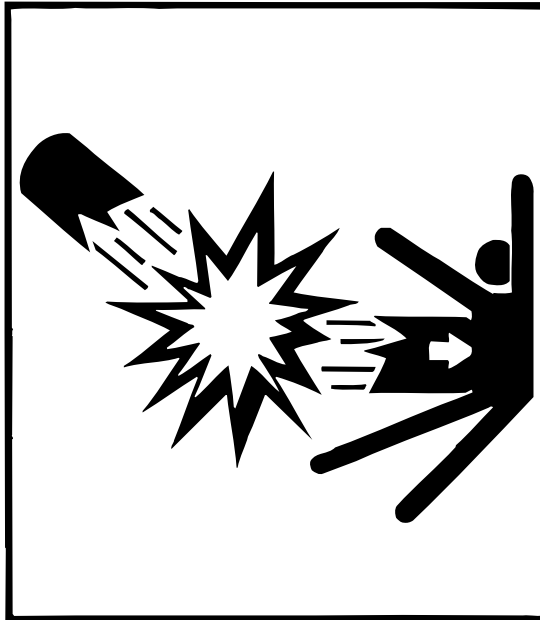

⚠ DANGER

EXPLODING TANK WILL CAUSE DEATH, SERIOUS INJURY OR PROPERTY DAMAGE

- Drain air tank after each use to prevent moisture build-up and corrosion which leads to tank failure.
- Assure that tank and compressor relief valves work properly, and are at correct pressure settings.
- DO NOT modify or repair air tank.
- NEVER move compressor with pressure in tank.



Failure to follow operating and maintenance procedures as outlined in this manual could result in equipment damage, personal injury or death. Follow all maintenance procedures and intervals.

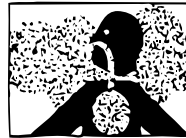

Do not use air from this compressor for breathing or food processing. Air from this compressor will cause severe injury or death if used for breathing or food processing.



Maintenance must be performed only by trained and qualified personnel, using correct tools, specified torques and approved replacement parts.

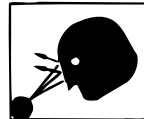

Hot oil under pressure can cause severe injury or death. Shut down, let cool and relieve pressure in compressor before servicing.



All electrical components and cable wiring must be installed and grounded in accordance with NFPA, national electrical codes and applicable state and local codes.



Do not overfill the compressor with oil. Use correct quantity of manufacturer's lubricant. Repair leaks and clean spills immediately.



Before removing guards or servicing the compressor, disconnect all power supplies. Display warning signs and lock out electrical circuits.



Compressors generate high temperatures. Do not touch or otherwise come in contact with hot surfaces. Doing so can cause severe personal injury.



All guards must be in position and secure before and during operation.

PRECAUTIONS

LISEZ CECI AVANT D'OPERER VOTRE COMPRESSEUR

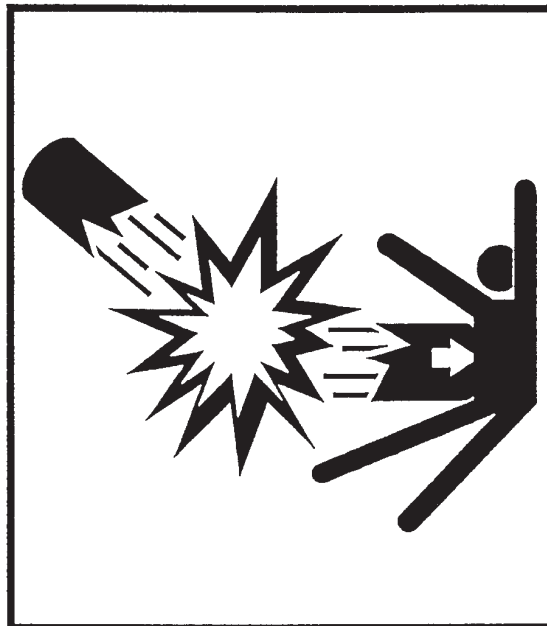

! DANGER

UN RESERVOIR QUI EXPLOSE CAUSERA LA MORT, BLESSURE SERIEUSE OU DES DOMMAGES DE MATERIAUX

- VIDER LE RESERVOIR A AIR APRES CHAQUE UTILISATION POUR PREVENIR UNE ACCUMULATION D'HUMIDITE ET CORROSION QUI CAUSERA LA RUPTURE DU RESERVOIR.
- S'ASSURER QUE LES SOUPAPES DE PRESSION DE SURETE DU RESERVOIR SOIT REGLEES AUX NIVEAUX DE PRESSIONS APROPRIEES.
- NE JAMAIS MODIFIER OU REPARER LE RESERVOIR A AIR.
- NE JAMAIS DEPLACER LE COMPRESSEUR AVEC UN RESERVOIR SOUS PRESSION.



NE PAS SUIVRE LES PROCEDURES D'OPERATION ET D'ENTRETIEN TELLES Q'INDIQUEES DANS CE MANUEL POURRAIT RESULTER EN UN BRIS D'EQUIPEMENT, BLESSURE PERSONNELLE OU LA MORT. SUIVEZ TOUTES LES PROCEDURES D'ENTRETIEN AUX INTERVALLES INDIQUEES.



NE PAS UTILISER L'AIR DU COMPRESSEUR POUR, LA RESPIRATION OU LE TRAITEMENT D'ALIMENTS. L'AIR DE CE COMPRESSEUR CAUSERA UNE BLESSURE SEVERE OU LA MORT S'IL EST UTILISE POUR LA RESPIRATION OU LE TRAITEMENT D'ALIMENTS.



TOUTE OPERATION D'ENTRETIEN DOIT ETRE EXECUTEE PAR UN PERSONNEL QUALIFIE, UTILISANT LES OUTILS APPROPRIES, LES TORQUES SPECIFIEES ET PIECES DE RECHANGE APPROUVEES.



L'HUILE CHAUDE SOUS PRESSION PEUT CAUSER UNE BLESSURE SEVERE OU LA MORT. ARRETEZ LE COMPRESSEUR, LAISSEZ REFROIDIR ET RELACHER LA PRESSION AVANT TOUT ENTRETIEN.



TOUTES COMPOSANTES ELECTRIQUES, CABLES ELECTRIQUES DOIVENT ETRE INSTALLES ET MIS A LA TERRE EN CONFORMANCE AVEC NFPA, LES REGLEMENTS DE SECURITE ELECTRIQUE NATIONAUX ET TOUT REGLEMENT DE SECURITE PROVINCIAL ET LOCAL APPLICABLE.



NE JAMAIS TROP REMPLIR D'HUILE LE COMPRESSEUR. UTILISER LA QUANTITE APPROPRIEE DE LUBRIFIANT DU MANUFACTURIER. REPARER TOUTE FUITE ET NETTOYEZ TOUT DEGAT D'HUILE IMMEDIATEMENT.



AVANT D'ENLEVER UNE PROTECTION OU DE TRAVAILLER SUR LE COMPRESSEUR, DEBRANCHER TOUTE LIGNE DE COURANT ALIMENTANT LE COMPRESSEUR. AFFICHEZ DES PANNEAUX D'AVERTISSEMENT ET BARRER LES CIRCUITS ELECTRIQUES.



LE COMPRESSEURS PRODUISENT DES TEMPERATURES ELEVEES. NE PAS TOUCHER OU FAIRE CONTACT AVEC CES SURFACES CHAUDES, CAR CELA POURRAIT CAUSER DES BLESSURES PERSONNELLES.



TOUTES PROTECTIONS MECANIQUE ET ELECTRIQUE DOIVENT ETRE EN POSITION ET SECURES AVANT ET PENDANT L'OPERATION.

Thank You

for selecting a **QUALITY** product by Lincoln Electric. We want you to take pride in operating this Lincoln Electric Company product ••• as much pride as we have in bringing this product to you!

Please Examine Carton and Equipment For Damage Immediately

When this equipment is shipped, title passes to the purchaser upon receipt by the carrier. Consequently, Claims for material damaged in shipment must be made by the purchaser against the transportation company at the time the shipment is received.

Please record your equipment identification information below for future reference. This information can be found on your machine nameplate.

Product _____

Model Number _____

Code Number or Date Code _____

Serial Number _____

Date Purchased _____

Where Purchased _____

Whenever you request replacement parts or information on this equipment, always supply the information you have recorded above. The code number is especially important when identifying the correct replacement parts.

On-Line Product Registration

- Register your machine with Lincoln Electric either via fax or over the Internet.
- For faxing: Complete the form on the back of the warranty statement included in the literature packet accompanying this machine and fax the form per the instructions printed on it.
- For On-Line Registration: Go to our **WEB SITE** at www.lincolnelectric.com. Choose "Quick Links" and then "Product Registration". Please complete the form and submit your registration.

Read this Operators Manual completely before attempting to use this equipment. Save this manual and keep it handy for quick reference. Pay particular attention to the safety instructions we have provided for your protection. The level of seriousness to be applied to each is explained below:

⚠ WARNING

This statement appears where the information **must** be followed **exactly** to avoid **serious personal injury** or **loss of life**.

⚠ CAUTION

This statement appears where the information **must** be followed to avoid **minor personal injury** or **damage to this equipment**.

	Page
Installation Instructions	Section A
Technical Specifications	A-1
Installation Precautions	A-2
Location / Ventilation	A-2
Stacking	A-2
Angle of Operation	A-2
Lifting	A-2
High Altitude Operation	A-3
Towing	A-3
Pre-Operation Engine and Compressor Service	A-3
Engine Oil	A-3
Compressor Oil	A-3
Fuel	A-4
Engine Cooling System	A-4
Break-In Period	A-4
Battery Connection	A-4
Spark Arrester	A-4
Welding Output Cables	A-5
Machine Grounding	A-5
Operating Instructions	Section B
Safety Instructions	B-1
Additional Safety Precautions	B-1
General Description	B-1
Recommended Applications	B-2
Welder	B-2
Auxiliary Power	B-2
Compressed Air	B-2
Product Application	B-2
Design Features and Advantages	B-2
Duty Cycle	B-2
Engine Controls: Function/Operation	B-3
Welder Controls: Function/Operation	B-3
Remote Control	B-4
Auxiliary Power Controls	B-4
Air Compressor Controls	B-4
Engine Operation	B-5
Starting Instructions	B-5
Typical Fuel Consumption	B-6
Accessories	Section C
Maintenance	Section D
Routine Maintenance	D-1
Periodic Maintenance	D-1
Pre Filter / Washer Separator	D-2
Water Separator Element	D-3
Engine And Compressor Maintenance Components	D-4
Spark Arrester	D-4
Troubleshooting Guide	Section E
Wiring Diagrams and Dimension Print	Section F
Parts Lists	Appendix
SAE-400 WELD'N AIR	P303 Series
SAE-400	P339 Series

TECHNICAL SPECIFICATIONS - SAE400 & SAE400 WELD'N AIR

INPUT - DIESEL ENGINE					
Make/Model	Description	Speed (RPM)	Displacement	Starting System	Capacities
Perkins 1004.42 Diesel Engine	4 cylinder 71 HP @ 1725 RPM	High Idle 1800 Low Idle 1100 Full Load 1725	256 cu. in (4.2 L)	12VDC batteries (2) & Starter	Fuel: 22.5 gal. 85.1 L
			Bore x Stroke 3.875" x 5.00" (98.4 mm x 127.0mm)		Oil: 8.5 Qts. 8.04 L Coolant: 3.6 gal. 13.63 L
RATED OUTPUT - WELDER					
Duty Cycle ⁽¹⁾	Welding Output			Volts at Rated Amps	
60% (NEMA)	400 amps			36 volts	
60% (Lincoln Plus)	400 amps			40 volts	
OUTPUT - WELDER AND GENERATOR					
Welding Range		Open Circuit Voltage		Auxiliary Power	
80 - 575 Amps		97 Max. OCV @ 1800 RPM		115/230 VAC 3000 Watts, 60 Hz. 100% Duty Cycle	
PHYSICAL DIMENSIONS					
HEIGHT	WIDTH	DEPTH		WEIGHT	
50.13 in.	28.00 in.	83.00 in.		SAE400	2125 lbs. 963.9 kg
1273.3 mm	711.2 mm	2108.2 mm		SAE400 WELD'N AIR	2428 lbs. 1101.3 kg
AIR COMPRESSOR OUTPUT - SAE400 WELD'N AIR ONLY					
Make/Model	Description	Delivery	Tank Capacity & Rating	Operating Pressure	Oil Capacity
IMT (Iowa Mold Tooling/ Diamond Air) Model DA435ELW	4-cylinder Reciprocating, Water Cooled, Pressure Lubricated Aluminum Alloy Block with Cast- Iron sleeves	35 CFM at 100 P.S.I. at 60% Duty Cycle ⁽¹⁾ 991 Liters/min. at 7.0 kg/cm ²	11 Gallons (41.6 Liters) Maximum Allowable Working Pressure 150 PSI (10.5 kg/cm ²)	Loads at 90 P.S.I. (6.3 kg/cm ²) Unloads at 130 P.S.I. (9.1 kg/cm ²)	1.33 Quarts (1.26 Liters) IMT's Synthetic Compressor Oil

⁽¹⁾ Based on a 10 minute period.

Read this entire installation section before you start installation.

SAFETY PRECAUTIONS

⚠ WARNING

Do not attempt to use this equipment until you have thoroughly read all operating and maintenance manuals supplied with your machine. They include important safety precautions, detailed engine starting, operating and maintenance instructions and parts lists.



ELECTRIC SHOCK can kill.

- Do not touch electrically live parts such as output terminals or internal wiring.
- Insulate yourself from the work and ground.
- Always wear dry insulating gloves.



ENGINE EXHAUST can kill.

- Use in open, well ventilated areas or vent exhaust outside
- Do not stack anything near the engine.



MOVING PARTS can injure.

- Do not operate with doors open or guards off.
- Stop engine before servicing.
- Keep away from moving parts

Only qualified personnel should install, use or service this equipment

LOCATION/VENTILATION

The welder should be located to provide an unrestricted flow of clean, cool air to the cooling air inlets and to avoid restricting the cooling air outlets. Also, locate the welder so that the engine exhaust fumes are properly vented to an outside area.

⚠ CAUTION

DO NOT MOUNT OVER COMBUSTIBLE SURFACES

Where there is a combustible surface directly under stationary or fixed electrical equipment, that surface should be covered with a steel plate at least .06”(1.6mm) thick, which should extend not less than 5.90(150mm) beyond the equipment on all sides.

STACKING

These machines cannot be stacked.

ANGLE OF OPERATION

To achieve optimum engine performance the machine should be run in a level position. The maximum angle of operation for the air compressor is 20 degrees in all directions. If the compressor is to be operated at an angle, provisions must be made for checking and maintaining the oil level at the normal (FULL) oil capacity in the compressor crankcase. The maximum angle of operation for the Perkins engine is 30 degrees in all directions. If the engine is to be operated at an angle, provisions must be made for checking and maintaining the oil level at the normal (FULL) oil capacity in the engine crankcase. When operating the welder at an angle, the effective fuel capacity will be slightly less than the specified 22.5 gallons.

LIFTING

The equipment lift bale should be used to lift the machine.

⚠ WARNING



- Lift only with equipment of adequate lifting capacity.
 - Be sure machine is stable when lifting.
 - Do not lift this machine using lift bale if it is equipped with a heavy accessory such as trailer or gas cylinder.
- FALLING EQUIPMENT can cause injury.**
- Do not lift machine if lift bale is damaged.
 - Do not operate machine while suspended from lift bale.

HIGH ALTITUDE OPERATION

At higher altitudes, output derating may be necessary. As a rule of thumb, derate the welder output 5% for every 500 meters (1640 ft.) above 1000 meters (3280 ft.).

Contact a Perkins Service Representative for any engine adjustments that may be required for high altitude operation.

TOWING

The recommended trailers for use with this equipment for in-plant and yard towing by a vehicle⁽¹⁾ are Lincoln's K767-1, K956-1 and K956-2. The K956-1 and K956-2 are also designed to be used at highway speeds⁽¹⁾. If the user adapts a non-Lincoln trailer, he must assume responsibility that the method of attachment and usage does not result in a safety hazard nor damage the welding equipment. Some of the factors to be considered are as follows:

1. Design capacity of trailer vs. weight of Lincoln equipment and likely additional attachments.
2. Proper support of, and attachment to, the base of the welding equipment so that there will be no undue stress to the trailer's framework.
3. Proper placement of the equipment on the trailer to insure stability side to side and front to back when being moved and when standing by itself.
4. Typical conditions of use, such as travel speed, roughness of surface on which the trailer will be operated, and environmental conditions.
5. Proper preventative maintenance of trailer.
6. Conformance with federal, state and local laws.¹

⁽¹⁾ For highway use, consult applicable federal, state and local laws regarding specific requirements for use on public highways, such as brakes, lights, fenders, etc.

VEHICLE MOUNTING

WARNING

Improperly mounted concentrated loads may cause unstable vehicle handling and tires or other components to fail.

- Only transport this equipment on serviceable vehicles which are rated and designed for such loads.
- Distribute, balance and secure loads so vehicle is stable under conditions of use.
- Do not exceed maximum rated loads for components such as suspension, axles and tires.
- Mount equipment base to metal bed or frame of vehicle.
- Follow vehicle manufacturer's instruction.

PRE-OPERATION ENGINE AND COMPRESSOR SERVICE

READ the engine and compressor operating and maintenance instructions supplied with this machine.

ENGINE OIL



The engine is shipped with the engine crankcase filled with high quality SAE 10W-30 oil (API class CD or better). Check the oil level before starting the engine. If it is not up to the full mark on the dip stick, add oil as required. Check the oil level every four hours of running time during the first 35 running hours. Refer to the engine Operator's Manual for specific oil recommendations and break-in information. The oil change interval is dependent on the quality of the oil and the operating environment. Refer to the engine Operator's Manual for the proper service and maintenance intervals.

AIR COMPRESSOR OIL (WELD'N AIR Only)



The WELD'N AIR is shipped with the compressor filled with a high quality synthetic compressor oil. If oil is needed add only Iowa Mold Tooling Co., Inc. (IMT) synthetic compressor oil until compressor is full.

CAUTION

The use of any other oil causes excessive carbon build up, and will void the warranty on the compressor.

Check the oil level daily. Refer to the compressor Operator's Manual for the proper service and maintenance intervals.

⚠ WARNING



- **Stop engine while fueling.**
- **Do not smoke when fueling.**
- **Keep sparks and flame away from tank.**
- **Do not leave unattended while fueling.**

DIESEL FUEL
can cause fire.

- **Wipe up spilled fuel and allow fumes to clear before starting engine.**
- **Do not overfill tank, fuel expansion may cause overflow.**

DIESEL FUEL ONLY

Fill the fuel tank with clean, fresh diesel fuel. The capacity of the fuel tank is 22.5 gallons (85.1 liters). See engine Operator's Manual for specific fuel recommendations.

NOTE: Before starting the engine, be sure the fuel shut-off valve on the sediment bowl is open by turning the handle counterclockwise.

ENGINE COOLING SYSTEM

The cooling system has been filled at the factory with a 50-50 mixture of ethylene glycol antifreeze and water. Check the radiator level and add a 50-50 solution as needed. (See Engine Manual or antifreeze container for alternate antifreeze recommendation.)

ENGINE BREAK-IN PERIOD

Lincoln Electric selects high quality, heavy-duty industrial engines for the portable welding machines we offer. While it is normal to see a small amount of crankcase oil consumption during initial operation, excessive oil use, wetstacking (oil or tar like substance at the exhaust port), or excessive smoke is not normal.

Larger machines with a capacity of 350 amperes and higher, which are operated at low or no-load conditions for extended periods of time are especially susceptible to the conditions described above. To accomplish successful engine break-in, most diesel-powered equipment needs only to be run at a reasonably heavy load within the rating of the welder for some period of time during the engine's early life. However, if the welder is subjected to extensive light loading, occasional moderate to heavy loading of the engine may sometimes be necessary. Caution must be observed in correctly loading a diesel/generator unit.

1. Connect the welder output studs to a suitable resistive load bank. Note that any attempt to short the output studs by connecting the welding leads together, direct shorting of the output studs, or connecting the output leads to a length of steel will result in catastrophic damage to the generator and voids the warranty.
2. Set the welder controls for an output current and voltage within the welder rating and duty cycle. Note that any attempt to exceed the welder rating or duty cycle for any period of time will result in catastrophic damage to the generator and voids the warranty.
3. Periodically shut off the engine and check the crankcase oil level.

BATTERY CONNECTION

⚠ WARNING

Use caution as the electrolyte is a strong acid that can burn skin and damage eyes.

Remove and discard the insulating caps from the negative battery terminals. Attach and tighten negative battery cable terminals.

NOTE: This machine is furnished with wet charged batteries; if unused for several months, the batteries may require a booster charge. Be careful to charge the batteries with the correct polarity. Make sure that the batteries are level while charging.

⚠ WARNING



GASES FROM BATTERY can explode.

- **Keep sparks, flame and cigarettes away from battery.**

To prevent **EXPLOSION** when:

- **INSTALLING A NEW BATTERY** — disconnect negative cable from old battery first and connect to new battery last.
- **CONNECTING A BATTERY CHARGER** — remove battery from welder by disconnecting negative cable first, then positive cable and battery clamp. When reinstalling, connect negative cable last. Keep well ventilated.
- **USING A BOOSTER** — connect positive lead to battery first then connect negative lead to negative battery lead at the lower control panel support.



BATTERY ACID can burn eyes and skin.

- Wear gloves and eye protection and be careful when working near battery.

- Follow instructions printed on battery.

IMPORTANT: To prevent ELECTRICAL DAMAGE WHEN:

- Installing new batteries.
- Using a booster.

Use correct polarity — **Negative Ground.**

To prevent BATTERY BUCKLING, tighten nuts on batteries only until snug. **DO NOT OVERTIGHTEN.**

⚠ WARNING



- Spark Arrester and Muffler may be hot!
- Allow engine to cool before servicing spark arrester!
- Do not operate engine while servicing spark arrester!

SPARK ARRESTER

Some federal, state or local laws may require that gasoline or diesel engines be equipped with exhaust spark arresters when they are operated in certain locations where unarrested sparks may present a fire hazard. The muffler included with this welder has been modified and now qualifies as a spark arrester. Mufflers on machines manufactured before this change do not qualify as spark arresters and when required by local regulations, a suitable spark arrester must be installed. Spark arresting mufflers will have a clean out service plug and will have "USDA FS 5100-1c QUALIFIED SPARK ARRESTER" stamped on the muffler shell. Any spark arrester must be serviced and properly maintained.

⚠ CAUTION

An incorrect arrester may lead to damage to the engine or adversely affect performance.

WELDING OUTPUT CABLES

With the engine off, connect the electrode and work cables to the studs provided. These connections should be checked periodically and tightened if necessary.

Listed in Table A.1 are copper cable sizes recommended for the rated current and duty cycle. Lengths stipulated are the distance from the welder to work and back to the welder again. Cable sizes are increased for greater lengths primarily for the purpose of minimizing cable voltage drop.

Table A.1 Combined Length of Electrode and Work Cables.

	TOTAL COMBINED LENGTH OF ELECTRODE AND WORK CABLES		
AMPS @60% Duty Cycle	Up to 100FT. Up to 31m	100-200FT. 31-61m	200-250FT. 61-76m
400	2/0 AWG	3/0 AWG	4/0 AWG

MACHINE GROUNDING

Because this portable engine driven welder creates its own power, it is not necessary to connect its frame to an earth ground, unless the machine is connected to premises wiring (home, shop, etc.).

To prevent dangerous electric shock, other equipment powered by this engine driven welder must:

- be grounded to the frame of the welder using a grounded type plug, or
- be double insulated.

When this welder is mounted on a truck or trailer, its frame must be securely connected to the metal frame of the vehicle. When this engine driven welder is connected to premises wiring such as that in a home or shop, its frame must be connected to the system earth ground. See the article on grounding in the latest U.S. National Electrical Code and the local code.

In general, if the machine is to be grounded, it should be connected with a #8 or larger copper wire to a solid earth ground such as a metal water pipe going into the ground for at least ten feet and having no insulated joints, or to the metal framework of a building which has been effectively grounded. The U.S. National Electrical Code lists a number of alternate means of grounding electrical equipment. A machine grounding stud marked with the \perp symbol is provided on the welding generator frame foot.

OPERATING INSTRUCTIONS

Read and understand this entire section before operating your equipment.

SAFETY INSTRUCTIONS

⚠ WARNING

Do not attempt to use this equipment until you have thoroughly read all operating and maintenance manuals supplied with your machine. They include important safety precautions, detailed engine starting, operating and maintenance instructions and parts lists.



ELECTRIC SHOCK can kill.

- Do not touch electrically live parts or electrodes with your skin or wet clothing.
- Insulate yourself from the work and ground.
- Always wear dry insulating gloves.
- Do not use AC welder if your clothing, gloves or work area is damp or if working on, under or inside workpiece.

Use the following equipment:



- Semiautomatic DC constant voltage (wire) welder.
- DC manual (stick) welder.
- AC welder with reduced voltage control.



ARC RAYS can injure eyes and burn skin.

- Wear eye, ear, and body protection.

- Only qualified personnel should install, use or service this equipment.
- Consult instruction manual before operating.

Before operating, read and understand the manufacturer's instructions for this equipment and the consumables to be used including the Material Safety Data Sheet (MSDS) and follow your employer's safety practices.

FUMES AND GASES can be dangerous to your health.

- Keep your head out of fumes.
- Use enough ventilation or exhaust at the arc, or both, to keep the fumes and gases from your breathing zone and general area.

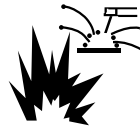

WELDING SPARKS can cause fire or explosion.

- Do not weld near flammable material.
- Do not weld on containers that have held flammable material.



MOVING PARTS can injure.

- Keep away from moving parts
- Do not operate with doors open or guards off.
- Stop engine before servicing.



ENGINE EXHAUST can kill.

- Use in open, well ventilated areas or vent exhaust outside.

ADDITIONAL SAFETY PRECAUTIONS

Always operate the welder with the hinged doors closed as these provide maximum protection from moving parts and insure proper cooling air flow.

Read carefully the Safety Precautions page in the Instruction Manual before operating this machine. Always follow these and any other safety procedures included in this manual and in the engine and compressor instruction manuals.

GENERAL DESCRIPTION

The SAE400 or SAE400 WELD'N AIR is a diesel engine driven welding power source. The machine uses a DC generator for DC stick electrode welding and an AC exciter for 115/230 VAC auxiliary power. As a generator it can supply up to 3,000 watts of 115/230 volt AC power. As a welder it provides up to 575 amps of DC constant current output. The belt driven air compressor of the SAE400 WELD'N AIR provides 35 CFM at 100 PSI compressed air.

The engine is a 71 Hp (54kw), 4-cylinder water cooled diesel made by Perkins.

RECOMMENDED APPLICATIONS

WELDER

The SAE400 or SAE400 WELD'N AIR provides excellent constant current DC welding output for stick (SMAW) welding. The field installed optional CV Adapter (K385-1) provides up to 500 amps at 35 volts of constant voltage output for semiautomatic welding.

AUXILIARY POWER

The SAE400 or SAE400 WELD'N AIR provides 3 KW of 115/230 VAC output for auxiliary power and emergency standby power.

COMPRESSED AIR

The SAE400 WELD'N AIR only, provides 35 CFM at 100 PSI compressed air for air arc gouging and air powered tools.

PRODUCT APPLICATION

TOOL	CFM - L/min	PSI - kg/cm ²
Arc Gouging, 3/8 in. (9.5)mm Electrode (Current Range, 350-600 amps DC)	16 453	18 1.27
Grinder, 2 in. (50.8mm) wheel	14-20 396-566	90 6.33
Chipping Hammer- Weight: 18lbs. (8.1kg.)	28-30 793-850	90 6.33
Air or Impact Wrenches: 1/2 in. to 3/4 in. (12.7-19.1mm)	30 850	90 6.33
Paint Sprayer	2-20 57-566	90 6.33
Drills Capacity 3/8 in. (9.5mm)	20-40 566-1133	90 6.33
Sand Blaster - 1/8 in. (3.2 mm) Nozzle diameter	26 736	100 7.03

DESIGN FEATURES AND ADVANTAGES

FOR STICK WELDING

- Excellent DC constant current output for stick welding applications.
- Continuous adjustment of both voltage and current for unsurpassed welds on demanding jobs.
- Remote control capability standard.

FOR AUXILIARY POWER

- 3,000 watts of 115/230 VAC, 60 Hz auxiliary power.
- One 20 amp 115 VAC duplex receptacle for up to 26 amps of 115 VAC power.
- One 15 amp, 230 VAC duplex receptacle for up to 13 amps of 230 VAC power.
- Weld and AC auxiliary power at the same time (within the limits shown on the chart below).

Welding Current, Amps @ NEMA Arc Volts	Using Only 115V Circuit, Amps	Using Only 230V Circuit, Amps	Total Aux. kVA
0	26	13	3.0
100	19.5	9.75	2.25
200	13	6.5	1.5
300	6.5	3.25	0.75
400	0	0	0

OTHER FEATURES

- Perkins 4-cylinder, water cooled diesel engine. Designed for long life, easy maintenance and excellent fuel economy.
- Engine protection system shuts the engine down for low engine oil pressure or high coolant temperature.
- Electronic Engine Idler. Engine automatically goes to low idle in 10 to 14 seconds after welding or use of auxiliary power stops. Includes high idle switch.
- Gauges for engine oil pressure, coolant temperature and battery charging ammeter.
- Engine hour meter standard.
- Extended range 22.5 gallon (85.1 L) fuel tank.

FOR COMPRESSED AIR (SAE400 WELD'N AIR only)

- 35 CFM at 100 PSI for air arc gouging and air powered tools.
- 11 Gallon air receiver tank system with integral over-pressure relief valve for smooth air delivery.
- Indicator light for compressor operation.
- Gauges for compressor air pressure and compressor oil pressure.
- No welding output derating required at maximum compressor load.

DUTY CYCLE

Duty cycle is based on a ten minute period and operation in an ambient temperature of 104°F(40°C).

The SAE400 & SAE400 WELD'N AIR are NEMA rated at 60% duty cycle. Duty cycle is based on a ten minute period. Therefore, a 60% duty cycle welder can be operated at nameplate rated output for 6 minutes out of every 10 minute period without overheating.

The auxiliary power can be used continuously (100% duty cycle) within its rated current capacities.

The air compressor on the SAE400 WELD'N AIR is rated at a 60% duty cycle based on a ten minute period as described above.

SAE400 & SAE400 WELD'N AIR



ENGINE CONTROLS

IGNITION SWITCH

When placed in the “ON” position, this switch energizes the fuel solenoid. When placed in the “OFF” position, the flow of fuel to the injection pump is stopped to shut down the engine.

“IDLER” SWITCH

The idler switch has two positions, “HIGH” and “AUTO”.

When in “HIGH” () position, the engine will run continuously at high idle.

When in “AUTO” () idle position, the idler operates as follows:

a. Welding

When the electrode touches the work, the welding arc is initiated and the engine accelerates to full speed.

After welding ceases (and no auxiliary power is being drawn), the engine will return to low idle after approximately 10 to 14 seconds.

b. Auxiliary Power

With the engine running at low idle and auxiliary power for lights or tools is drawn (approximately 100-150 watts or greater) from the receptacles, the engine will accelerate to high speed. If no power is being drawn from the receptacles (and not welding) for 10-14 seconds, the idler reduces the engine speed to low idle.

ENGINE TEMPERATURE GAUGE

Displays the coolant temperature in the engine block.

ENGINE OIL PRESSURE GAUGE

Displays the oil pressure to the engine. When the engine starts running, watch for the oil pressure to build up. If no pressure shows within 30 seconds, stop the engine and consult the engine instruction manual.

BATTERY CHARGING AMMETER

Displays the current going from the charging alternator into the batteries. It is normal for charging current to be high (above 15 amps) after starting or when the batteries are ‘low’ on charge.

ENGINE HOUR METER

The engine hour meter records the total running time on the engine in hours. It can be used to keep a record of maintenance on the engine and or welder.

ENGINE PROTECTION SYSTEM

The engine protection system shuts down the engine under high coolant temperature or low engine oil pressure conditions by allowing the fuel solenoid valve to close.

WELDER CONTROLS

POLARITY SWITCH

Turn the Arc Polarity switch to electrode positive or electrode negative as required for each particular application.

CONTROL OF WELDING CURRENT

Purpose of Controls

The continuous “Current Control” is the main current adjuster. The “Job Selector” is both a fine current adjuster and the continuous Open Circuit Voltage adjuster. Open Circuit Voltage (OCV) controls the arc characteristics.

“Job Selector”

The “Job Selector” dial is divided into four colored sections providing OCV ranges as follows:

Color	Title	OCV Range
White	Large Electrodes	High OCV
Black	Normal Welding	Medium OCV
Red	Overhead & Vertical	Low OCV
Grey	Special Applications	Extra-Low OCV

The “Job Selector” is usually set in the black range because it provides a soft “Buttering” arc desired for most welding. Some operators prefer to set the “Job Selector” in the red range for a snappy “Digging” arc when welding vertical up or overhead.

“Current Control”

CAUTION

Do not adjust the “Current Control” while welding because this can damage the control.

The “Current Control” dial is calibrated in amperes on three separate colored dials corresponding to the white, black and red ranges of the “Job Selector” dial. For example: when the “Job Selector” is set on the black range, the approximate welding current is indicated on the black scale of the “Current Control” dial.

How to Set the Controls

Assume you want a normal soft arc and about 135 amps, using a 5/32" (4.0 mm) electrode:

1. Set the "Job Selector" at the center of the black range.
2. Set the "Current Control" to read 135 amps on the black dial.
3. Start to weld.
4. If you want a little more current, turn the "Job Selector" up (counterclockwise) to increase current. If you want a little less current, turn the "Job Selector" down (clockwise) to decrease current.
5. If dialing the desired current with the "Job Selector" moves the setting outside the black range causing undesirable arc characteristics, turn the "Job Selector" back to the center of the black range. Then turn the "Current Control" up or down a little as needed. Readjust the "Job Selector" for the exact characteristics and current desired.

REMOTE CONTROL

A receptacle and "Local/Remote" control switch on the lower front control panel and a remote control box with 100 ft. (30.5 m) of cord for adjusting the OCV at the welding site are standard. Putting the switch in the "REMOTE" position allows fine current control at the remote control box while placing the switch in the "LOCAL" position allows fine current control at the "Job Selector" on the machine. When using the optional field installed CV adapter (K385-1) the "Local/Remote" switch is only active in the "VV" mode.

AUXILIARY POWER CONTROLS

115 VAC Receptacle

One 20 amp, 115 VAC duplex receptacle provides 115 VAC for auxiliary power. A total of 26 amps can be drawn from this receptacle.

230 VAC Receptacle

One 15 amp, 230 VAC duplex receptacle provides 230 VAC for auxiliary power. A total of 13 amps can be drawn from this receptacle.

Circuit Breakers

The circuit breakers provide separate overload current protection for each half of the 115 V duplex receptacle. The circuit breakers provide overload current protection in both current carrying wires of the 230 V duplex receptacle.

Ground Stud

Provides a connection point for connecting the machine to earth ground. For the safest grounding procedure refer to "Machine Grounding" in the INSTALLATION section of this manual.

AIR COMPRESSOR CONTROLS - (SAE400 WELD'N AIR ONLY)

COMPRESSOR ON/OFF SWITCH

Placing the "ON/OFF" switch in the "ON" position allows the "pressure switch" (factory preset) to control the air compressor through an electric clutch. When the system pressure falls below 90 psi, the "pressure switch" engages the clutch and compressor. When the system pressure goes above 130 psi, the "pressure switch" disengages the clutch and compressor.

The "ON/OFF" switch needs to be in the "ON" position when using compressed air. When placed in the "OFF" position this switch does not allow the compressor clutch to engage regardless of the tank pressure.

The "ON/OFF" switch should be in the "OFF" position while starting the engine. This will minimize the load on the starter motor.

COMPRESSOR OPERATING LIGHT

This light is on when the compressor "ON/OFF" switch is in the "ON" position.

COMPRESSOR AIR PRESSURE GAUGE

This gauge displays the air pressure in the air receiver tanks.

COMPRESSOR OIL PRESSURE GAUGE

This gauge displays the compressor oil pressure. Oil is under pressure only when the compressor clutch is engaged.

ENGINE OPERATION

CAUTION

Do not adjust the high idle engine speed (rpm) above the factory setting specification as this will overspeed the air compressor and void it's warranty.

STARTING INSTRUCTIONS

Be sure all Pre-Operation Maintenance has been performed. (See INSTALLATION section of this manual). Set the air compressor "ON/OFF" switch in the "OFF" position. To start the engine, place ignition toggle switch in the "ON" position. Engage the starter button. When the engine starts running, observe the engine oil pressure. If no pressure shows within 30 seconds, stop the engine and consult the engine operating manual. To stop the engine, place the ignition toggle switch in the "OFF" position.

When an engine is started for the first time, some of the oil will be needed to fill the passages of the lubricating system. Therefore, on initial starting, run the engine for about five minutes and then stop the engine and recheck the oil. If the level is down, fill to the full mark again. The engine controls were properly set at the factory and should require no adjusting when received.

For added safety always operate the welder with the doors closed. Further, leaving the doors open changes the designed air flow and may cause engine, generator or compressor overheating.

COLD WEATHER STARTING

WARNING

Never use any other starting aids, such as ether, when using the "Thermostart" system.

When overnight temperatures are between 10°F (-12°C) and freezing, use the standard "Thermostart" starting system installed on all engines. Follow the instructions on the start panel nameplate and in the engine manual shipped with the welder. With fully charged batteries and the proper weight oil, the "Thermostart" system operates satisfactorily even down to about 0°F (-18°C).

AIR COMPRESSOR (SAE400 WELD'N AIR only)

Cylinder head stud torque must be checked after initial 8 to 10 hours of operation. See compressor operator's manual for details. Compressor mounting bolts should be checked for tightness after initial 8 to 10 hours of operation.

TYPICAL FUEL CONSUMPTION

The typical fuel consumption of the SAE400 and SAE400 WELD'N AIR for various operating scenarios is shown below:

Low Idle - No Load 1100 RPM	.35 gal./hr. (1.32 L./hr.)
--------------------------------	-------------------------------

High Idle - No Load 1800 RPM	.75 gal./hr. (2.84 L./hr.)
---------------------------------	-------------------------------

Welding Load 400 Amps, 40 Volts	1.92 gal./hr. (7.27 L./hr.)
------------------------------------	--------------------------------

Auxiliary Power 3000VA	.96 gal./hr. (3.63 L./hr.)
---------------------------	-------------------------------

Air Compressor (SAE400 WELD'N AIR Only)	1.04 gal./hr. (3.94 L./hr.)
--	--------------------------------

400 Amps, 40 Volts Load with Air Compressor "ON" (SAE400 WELD'N AIR Only)	2.22 gal./hr. (8.40 L./hr.)
---	--------------------------------

Auxiliary Power 3000 VA with Air Compressor "ON" (SAE400 WELD'N AIR Only)	1.20 gal./hr. (4.54 L./hr.)
--	--------------------------------

K930-2 Hi-Freq™ - Provides high frequency plus a gas valve for TIG welding. A water valve is available as an option. Requires 115 volt AC input. (Limited to 250A - 60% Duty Cycle).

K802-D Power Plug Kit - Kit includes male plugs for each auxiliary receptacle.

K767-1 Trailer - A 4-wheel steerable trailer for in-plant and yard towing⁽¹⁾ with E78-14 load range (B) tubeless tires. Mounts directly to welder base.

K956-1 Trailer - A 2-wheel trailer designed for road⁽¹⁾, off road, in-plant and yard towing. Trailer mounts directly to welder base.

¹For highway use, consult applicable federal, state and local laws regarding possible requirements for brakes, lights, fenders, etc.

WARNING

Pipe Thawing with an arc welder can cause fire, explosion, damage to electric wiring or to the arc welder if done improperly. The use of an arc welder for pipe thawing is not approved by the CSA, nor is it recommended or supported by Lincoln Electric.

K704 Standard Accessory Kit - Includes electrode and work cables, headshield, work clamp and electrode holder.

K385-1 CV Adapter - Provides constant voltage output for semiautomatic welding. (Field installation only).

K2144-1 Oil Drain Kit - Includes ball valve, hose and clamp.

K1847-1 Spark Arrestor Kit

K1690-1 GFCI RECEPTACLE KIT

Includes one UL approved 120V ground fault circuit interrupter duplex type receptacle with cover and installation instructions. Replaces the factory installed 120V duplex receptacle. Each receptacle of the GFCI Duplex is rated at 20 Amps, the maximum total current from the GFCI Duplex is limited to the 20 Amps. Two kits are required.

K2303-1 SHEET METAL KIT- For SAE400 model K1278-5.

⚠ WARNING



ELECTRIC SHOCK can kill.

- Do not touch electrically live parts such as output terminals or internal wiring



ENGINE EXHAUST can kill.

- Use in open, well ventilated areas or vent exhaust outside



MOVING PARTS can injure.

- Do not operate with doors open or guards off
- Stop engine before servicing
- Keep away from moving parts

- Remove guards only when necessary and replace when work requiring removal is complete.
- Only qualified personnel should install, use, or service this equipment.

ROUTINE MAINTENANCE

At the end of each day's welding, refill the fuel tank to minimize moisture condensation in the tank. Also, running out of fuel tends to draw dirt into the fuel system. Check the engine crankcase and compressor oil levels.

If the fuel supply runs out while the fuel pump is operating, air may be entrapped in the fuel distribution system. If this happens, bleeding of the fuel system may be necessary. See the engine instruction manual.

COMPRESSOR AIR RECEIVER TANKS - (SAE400 WELD'N AIR ONLY)

Drain the condensation from the tanks after each use by opening the drain valve located at the lower right rear of the welder.

ENGINE AIR FILTER

The engine air filter element is a dry cartridge type. It is located above the engine. It can be cleaned and re-used; however, damaged elements should not be washed or re-used. Remove loose dirt from element with compressed air or water hose directed from inside out. Compressed Air: 100 psi maximum. The filter should never be removed while the engine is running.

PERIODIC MAINTENANCE

1. Blow out the welder and controls with an air hose at least once every two months. In particularly dirty locations, this cleaning may be necessary once a week. Use low pressure air to avoid driving dirt into the insulation.
2. The current control reactor brushes are self-lubricating and should not be greased. Keep the contacts clean. This control should be moved from maximum to minimum daily to prevent the controls from sticking.
3. See the engine Instruction Manual for periodic engine maintenance information. Change the crankcase oil at regular intervals using the proper grade of oil as recommended in the engine operating manual. Change the oil filter in accordance with the instructions in the engine operating manual. When the oil filter is changed add one quart of oil to the crankcase to replace the oil held in the filter during operation.
4. See the compressor operator's manual for periodic compressor maintenance information. Change the compressor oil at regular intervals using only Iowa Mold Tooling Co., Inc. (IMT) synthetic compressor oil as recommended in the compressor operating manual.

⚠ CAUTION

The use of any other oil causes excessive carbon build up, and will void the warranty on the compressor.

5. Belts tend to loosen after the first 30 or 40 hours of operation. Check the cooling fan belt and tighten if necessary. **DO NOT OVER TIGHTEN.** The compressor belt does not require any adjustment.

BEARING MAINTENANCE

This welder is equipped with a double-shielded ball bearing having sufficient grease to last indefinitely under normal service. Where the welder is used constantly or in excessively dirty locations, it may be necessary to add one-half ounce of grease per year. A pad of grease one inch wide, one inch long and one inch high weighs approximately one-half ounce. Over greasing is far worse than insufficient greasing.

When greasing the bearings, keep all dirt out of the area. Wipe the fittings completely clean and use clean equipment. More bearing failures are caused by dirt introduced during greasing than from insufficient grease.

SAE400 & SAE400 WELD'N AIR

COMMUTATOR AND BRUSH MAINTENANCE

WARNING

Uncovered rotating equipment can be dangerous. Use care so your hands, hair, clothing or tools do not catch in the rotating parts. Protect yourself from particles that may be thrown out by the rotating armature when stoning the commutator.

The generator brushes are properly adjusted when the welder is shipped. They require no particular attention. **DO NOT SHIFT THE BRUSHES** or adjust the rocker setting.

Shifting of the brushes may result in:

- Change in machine output
- Commutator Damage
- Excessive brush wear

Periodically inspect the commutator, slip rings and brushes by removing the covers. **DO NOT** remove or replace these covers while the machine is running.

Commutators and slip rings require little attention. However, if they are black or appear uneven, have them cleaned by an experienced maintenance man using fine sandpaper or a commutator stone. Never use emery cloth or paper for this purpose.

NOTE: If the welder is used in dirty or dusty locations, or if the welder is not used for prolonged periods of time, it may be necessary to clean the commutator and slip rings more often.

Replace brushes when they wear within 1/4" of the pig-tail. A complete set of replacement brushes should be kept on hand. Lincoln brushes have a curved face to fit the commutator. Have an experienced maintenance man seat these brushes by lightly stoning the commutator as the armature rotates at full speed until contact is made across the full face of the brushes. After stoning, blow out the dust with low pressure air.

To seat the slip ring brushes, position the brushes in place. Then slide one end of a piece of fine sandpaper between slip rings and brushes with the coarse side against the brushes. With slight additional finger pressure on top of the brushes, pull the sandpaper around the circumference of the rings, in direction of rotation only - until brushes seat properly. In addition, stone slip ring with a fine stone. Brushes must be seated 100%.

Arcing or excessive exciter brush wear indicates a possible misaligned shaft. Have an authorized Field Service Shop check and realign the shaft.

COOLING SYSTEM

The SAE400 and SAE400 WELD'N AIR are equipped with a pressure radiator. Keep the radiator cap tight to prevent loss of coolant. Clean and flush the cooling system periodically to prevent clogging the passage and overheating the engine. When antifreeze is needed, always use the permanent type.

PRE FILTER / WASHER SEPARATOR

WARNING

When working on the fuel system



- Keep unguarded lights away, do not smoke !
- Do not spill fuel !

The SAE-400 and SAE400 Weld'n Air machines with Codes 10884 and above are equipped with a **Fuel Pre-Filter/Water Separator Assembly** located before the lift pump mounted to the engine block.

FUEL PRE-FILTER/WATER SEPARATOR ASSEMBLY

The pre-filter is a 150 micron screen designed to protect against gross fuel contamination of the water separator element and the Secondary Fuel Filter. If the pre-filter becomes plugged it may be removed, inspected, cleaned and reinstalled. In general this only needs to be done with each water separator element change (about every 1,000 hrs.) However if at any time excessive fuel contamination is suspected or a sudden fall-off in engine performance is detected the pre-filter screen should be inspected and cleaned. Follow the following procedure:

1. Close the fuel shutoff valve located on the fuel strainer mounted to the under side of the fuel tank.
2. Unscrew the cap ring located on the top of the filter header and remove the plastic center cap and O-ring.
3. Remove the large white volume plug located directly under the center cap in the upper cavity of the filter header. Use a small screwdriver (or similar device) to lift the plug part way out of the cavity to assist with its removal.

Be careful not to damage the pre-filter screen with the tool used to remove the plug.

SAE400 & SAE400 WELD'N AIR



4. Using a pair of pliers, gently tug on the pull tabs of the pre-filter screen in an alternating pattern to gradually remove the pre-filter screen.
 5. Brush off any debris and rinse in diesel fuel.
 6. Re-install the pre-filter screen into the upper cavity of the filter header making sure the four pull tabs are pointing up. Putting your fingers on the pull tabs, push down evenly until the lower body of the pre-filter screen contacts the floor of the upper cavity.
 7. Re-insert the large white volume plug into the upper cavity.
 8. Place the O-ring onto the angled seal surface of the filter header and re-install the plastic cap. Make sure its flange rests on the O-ring.
 9. Screw on the cap ring and tighten hand tight.
 10. Remember to open the fuel shutoff valve before starting the engine.
5. Slide the quick change ring up over the element and rotate counter clockwise until an audible click or pop is heard. If you do not hear the click you have not rotated the ring far enough and the element is not in the locked position. Another indication that the ring is in the locked position is that one set (it doesn't matter which one) of arrows located on the outside of the ring should be located directly under the air vent valve.
 6. Open the fuel shutoff valve.
 7. Open the air vent valve on the front of the filter header until fuel emerges free of air bubbles and then close the air vent valve.

Note : Consult your engine operation manual for information on air bleeding the entire fuel system

WATER SEPARATOR ELEMENT

The water separator element is a two stage filter with a special filtration/water separating media, and an expanded water reservoir providing maximum protection against water in the fuel. The recommended change interval for the water separator element is 1,000 hours. The procedure for changing the element is as follows:

1. Close the fuel shutoff valve located on the fuel strainer mounted to the under side of the fuel tank.
2. Rotate the quick change ring (located just below filter header) clockwise approximately 1/2 turn and slide it down and off of the element.
3. Grasp the element and pull down with a slight rocking motion to remove the element from the grommet post on the bottom of the filter header.
4. Slide the new element onto the grommet post on the bottom of the filter header until the element no longer easily moves up into the filter header. Now rotate the element (may take almost 1 full turn) with a slight upward pressure until the element begins to further engage the header. With the proper orientation now established apply additional pressure to seat the element in the filter header. You should feel the element "pop" into place when properly seated.

Note: The element will only go on one way. Never use excessive force when mounting the element to the header.

SAE400 & SAE400 WELD'N AIR



ENGINE AND COMPRESSOR MAINTENANCE COMPONENTS

ITEM	MAKE	PART NUMBER
Engine Air Filter	Donaldson	P181052
Fan Belt	Perkins	2614B550
Compressor Belt (SAE400 WELD'N AIR only)	Lincoln Gates	S23887 2/A40
Fuel Filter	Perkins	26560143
Engine Oil Filter	Perkins	2654403
(Codes 10884 & Above) Water Separator Element	Lincoln Stanadyne	M16890-C 31572
(Codes 10884 & Above) Fuel Pre-Filter Screen	Lincoln Stanadyne	M16890-B 29575

REPLACING AIR COMPRESSOR DRIVE BELT (SAE400 WELD'N AIR only)

⚠ CAUTION

Belt is tensioned using a automatic tensioning device. Remove with care.

To remove compressor belt:

1. Remove nut and lock washer from lower locking bolt on idler tension flange.
2. Loosen center mounting bolt on idler tensioner 1/2 turn or until it moves freely.
3. Using a pipe wrench or equivalent tool, turn tensioner body slightly to free locking bolt. Remove locking bolt and slowly release tension on belt. Remove belt.

Note: Do not loosen or remove compressor mounting bolts. Pulley misalignment may result.

To install belt (after following above procedure):

1. Mount belt into pulley grooves and over idler pulley.
2. Using a pipe wrench or suitable tool, turn idler body to realign locking slot in idler flange with locking hole. Insert locking bolt and tighten before releasing idler body. Tighten center mounting bolt.

Note: Ensure that both belt strands are running properly in pulley grooves.

SPARK ARRESTOR

⚠ WARNING



- Spark Arrester and Muffler may be hot!
- Allow engine to cool before servicing spark arrester!
- Do not operate engine while servicing spark arrester!

For machines with separate spark arresting units: Service the spark arrester every 100 hours of operation or twice a year, whichever occurs first. Service as follows:

1. Stop engine and allow to cool.
2. Loosen clamp and remove spark arrester from machine.
3. Remove locknut on top of spark arrester housing and lift off cap.
4. Separate plates and clean if necessary.
5. Inspect plates and housing for holes or cracks. Replace spark arrester if damaged.
6. Assemble spark arrester using reverse order: step 3, then step 2.

For machines with integral spark arresting mufflers: Service spark arrester every 250 hours. Service as follows:

1. Stop engine and allow to cool.
2. Remove clean out plug from side of spark arrester.
3. Without damaging the spark arrester, gently tap on the arrester shell near the clean out plug.
4. Once particles are removed, replace the clean out plug.

SAE400 & SAE400 WELD'N AIR

HOW TO USE TROUBLESHOOTING GUIDE

⚠ WARNING

Service and Repair should only be performed by Lincoln Electric Factory Trained Personnel. Unauthorized repairs performed on this equipment may result in danger to the technician and machine operator and will invalidate your factory warranty. For your safety and to avoid Electrical Shock, please observe all safety notes and precautions detailed throughout this manual.

This Troubleshooting Guide is provided to help you locate and repair possible machine malfunctions. Simply follow the three-step procedure listed below.

Step 1. LOCATE PROBLEM (SYMPTOM).

Look under the column labeled “PROBLEM (SYMPTOMS)”. This column describes possible symptoms that the machine may exhibit. Find the listing that best describes the symptom that the machine is exhibiting.

Step 2. POSSIBLE CAUSE.

The second column labeled “POSSIBLE CAUSE” lists the obvious external possibilities that may contribute to the machine symptom.

This column provides a course of action for the Possible Cause, generally it states to contact your local Lincoln Authorized Field Service Facility.

If you do not understand or are unable to perform the Recommended Course of Action safely, contact your local Lincoln Authorized Field Service Facility.

Step 3. RECOMMENDED COURSE OF ACTION

⚠ WARNING



ELECTRIC SHOCK can kill.

- Do not touch electrically live parts such as output terminals or internal wiring.



ENGINE EXHAUST can kill.

- Use in open, well ventilated areas or vent exhaust outside.



MOVING PARTS can injure.

- Do not operate with doors open or guards off.
- Stop engine before servicing.
- Keep away from moving parts.

- Remove guards only when necessary and replace when work requiring removal is complete.
- Only qualified personnel should install, use or service this equipment.

⚠ CAUTION

If for any reason you do not understand the test procedures or are unable to perform the tests/repairs safely, contact your **Local Lincoln Authorized Field Service Facility** for technical troubleshooting assistance before you proceed.

SAE400 & SAE400 WELD'N AIR



Observe all Safety Guidelines detailed throughout this manual

PROBLEMS (SYMPTOMS)	POSSIBLE CAUSE	RECOMMENDED COURSE OF ACTION
FUNCTION PROBLEMS		
<p>Machine fails to hold the "heat" constantly.</p>	<p>Rough or dirty commutator.</p> <p>Brushes may be worn down to limit of life.</p> <p>Brush springs may be broken.</p> <p>Field circuit may have variable resistance connections or intermittent open circuit, due to loose connections or broken wire.</p> <p>Electrode or work lead connections may be poor.</p> <p>Wrong grade of brushes may be installed on generator.</p> <p>Field rheostat may be making poor contact and overheating.</p> <p>"Current Control" may not be operating properly.</p> <p>"Current Control" brushholder contact springs may be worn out or missing. Contact surface may be dirty, rough and pitted.</p> <p>"Current Control" brushholder support stud and mating contact surfaces may be dirty or pitted and burned.</p> <p>Engine running at varying speeds.</p>	<p>True and clean commutator.</p> <p>Replace brushes.</p> <p>Replace brush springs.</p> <p>Check field current with ammeter to discover varying current. This applies to both the main generator and exciter.</p> <p>Tighten all connections.</p> <p>Use only the recommended Lincoln brushes.</p> <p>Inspect and clean rheostat.</p> <p>Check for loose or missing set screw in control handles.</p> <p>Inspect. Replace needed parts. Clean internal contact surface of control device. Do not lubricate. Smooth rough surfaces.</p> <p>If brushholder internal contact surface is pitted and burned, replace the brushholder and support stud. If the contact surface is dirty, clean off the brushholder stud and internal contact surface. Apply mixture of three parts silicone grease and one part zinc powder (by weight) to stud.</p> <p>Set welder controls for maximum output and weld. Then, while welding, check engine rpm. The engine should be running at full speed. If indicator shows a significant difference, consult your engine manual.</p>

 **CAUTION**

If for any reason you do not understand the test procedures or are unable to perform the tests/repairs safely, contact your **Local Lincoln Authorized Field Service Facility** for technical troubleshooting assistance before you proceed.

SAE400 & SAE400 WELD'N AIR



Observe all Safety Guidelines detailed throughout this manual

PROBLEMS (SYMPTOMS)	POSSIBLE CAUSE	RECOMMENDED COURSE OF ACTION
FUNCTION PROBLEMS		
Welder runs but fails to generate current.	<p>Generator or exciter brushes may be loose or missing.</p> <p>Exciter may not be operating.</p> <p>Field circuit of generator or exciter may be open.</p> <p>Polarity reversing switch may be in the neutral position.</p> <p>Exciter may have lost excitation.</p>	<p>Be sure that all brushes bear on the commutator and have proper spring tension.</p> <p>Check exciter output voltage with voltmeter or lamp.</p> <p>Check for open circuits in rheostat, field leads and field coils. Also check resistors.</p> <p>Put handle in positive or negative position.</p> <p>Check components and continuity in flashing circuit.</p>
Welding arc is loud and spatters excessively.	<p>Series field circuit may be open circuited.</p> <p>Current setting may be too high.</p> <p>Polarity may be wrong.</p>	<p>Check circuit with ringer or voltmeter.</p> <p>Check setting and current output with ammeter.</p> <p>Check polarity. Try reversing polarity or try an electrode of the opposite polarity.</p>

 **CAUTION**

If for any reason you do not understand the test procedures or are unable to perform the tests/repairs safely, contact your **Local Lincoln Authorized Field Service Facility** for technical troubleshooting assistance before you proceed.

SAE400 & SAE400 WELD'N AIR



Observe all Safety Guidelines detailed throughout this manual

PROBLEMS (SYMPTOMS)	POSSIBLE CAUSE	RECOMMENDED COURSE OF ACTION
FUNCTION PROBLEMS		
<p>Welding current too great or too small compared to indication on the dial.</p>	<p>“Current Control” shaft and handle may have turned slightly in the insulated bushing of the current control brushholder, caused by turning handle too hard against one of the stops.</p> <p>Exciter output low causing low output compared to dial indication.</p> <p>“Current Control” set to minimum and welder output so great that engine stalls when arc is struck.</p>	<p>With current control against the minimum stop, set pointer to within 1/8” of the last scale division.</p> <p>Check for shorts in exciter armature with growler.</p> <p>Check to see that series field is properly connected and not shorted.</p>
<p>Welder has output and no control</p>	<p>Local/Remote switch is in wrong position.</p>	<p>Place switch in “LOCAL” position to control output at the welder. Place switch in “REMOTE” position to control output remotely.</p>

 **CAUTION**

If for any reason you do not understand the test procedures or are unable to perform the tests/repairs safely, contact your **Local Lincoln Authorized Field Service Facility** for technical troubleshooting assistance before you proceed.

SAE400 & SAE400 WELD'N AIR



Observe all Safety Guidelines detailed throughout this manual

PROBLEMS (SYMPTOMS)	POSSIBLE CAUSE	RECOMMENDED COURSE OF ACTION
FUNCTION PROBLEMS		
No auxiliary power	Circuit Breakers open.	Check and reset breakers. If breakers keep tripping check connections to auxiliary receptacles. Also make sure load does not exceed receptacle's current rating.
	Faulty connections to auxiliary receptacles.	Check connections.

 **CAUTION**

If for any reason you do not understand the test procedures or are unable to perform the tests/repairs safely, contact your **Local Lincoln Authorized Field Service Facility** for technical troubleshooting assistance before you proceed.

SAE400 & SAE400 WELD'N AIR



WIRING DIAGRAM - SAE-400 WELD'N AIR

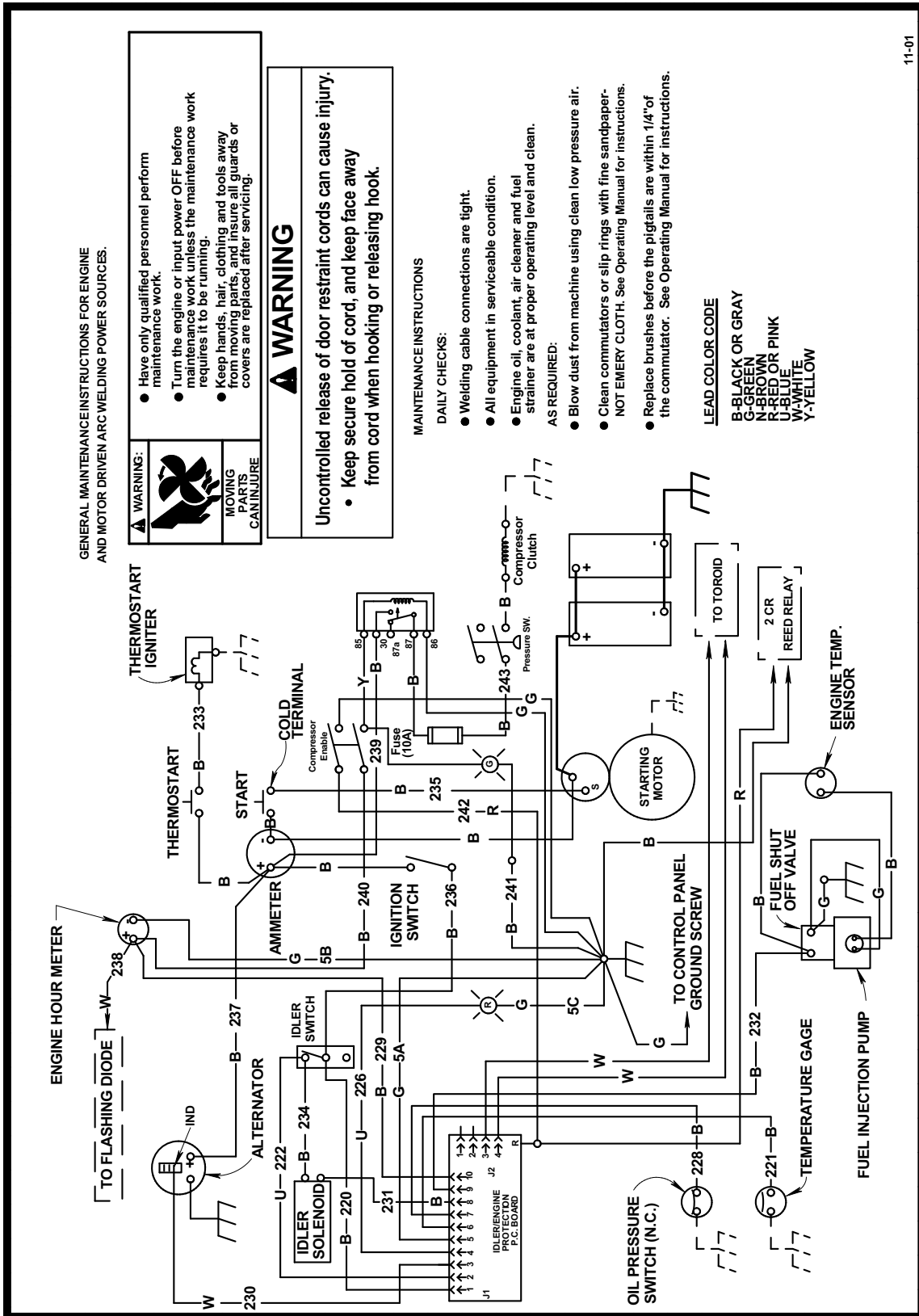

11-01

M19232

NOTE: This diagram is for reference only. It may not be accurate for all machines covered by this manual. The specific diagram for a particular code is pasted inside the machine on one of the enclosure panels.



WIRING DIAGRAM - SAE-400 PERKINS

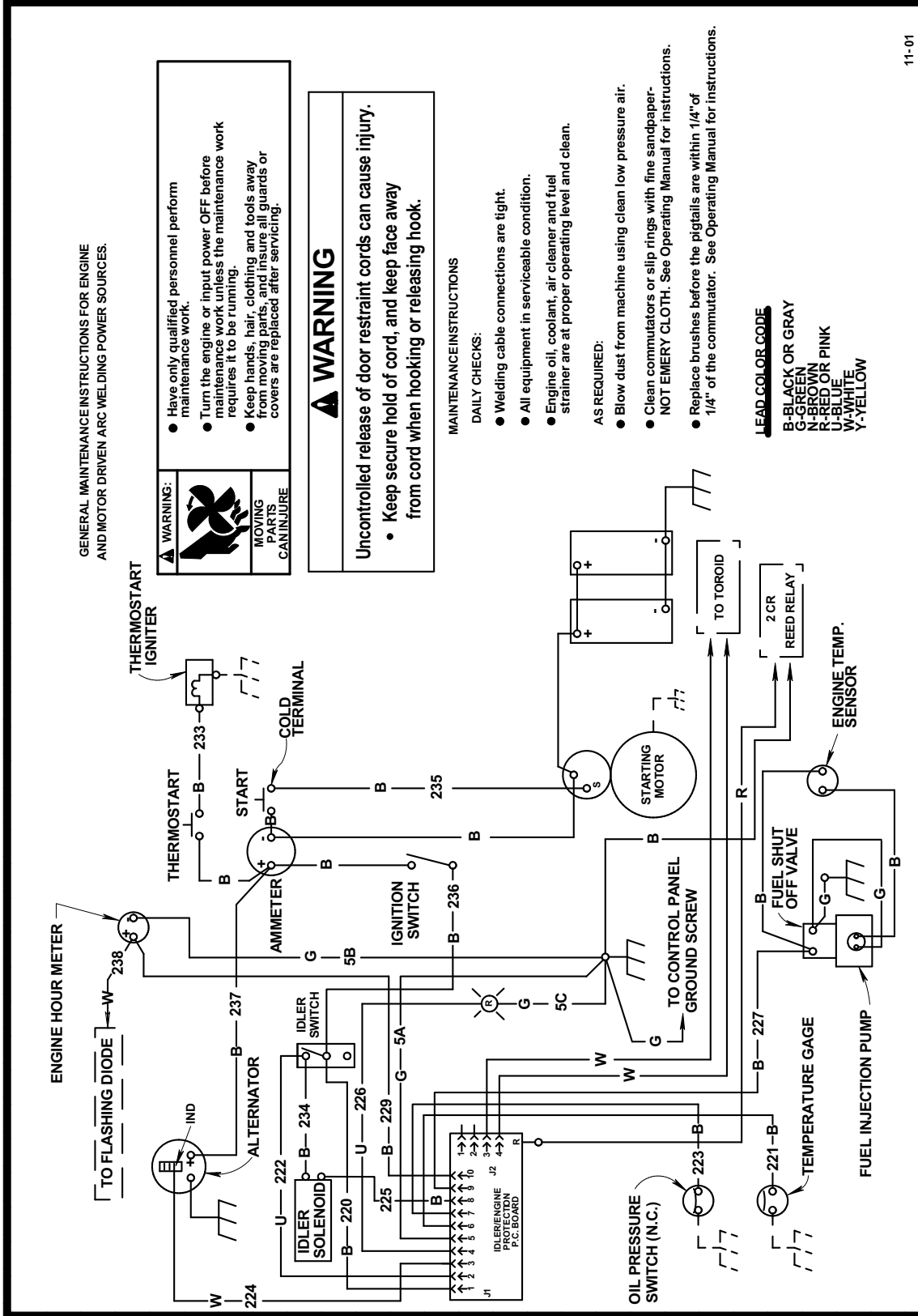

11-01

M19233

NOTE: This diagram is for reference only. It may not be accurate for all machines covered by this manual. The specific diagram for a particular code is pasted inside the machine on one of the enclosure panels.

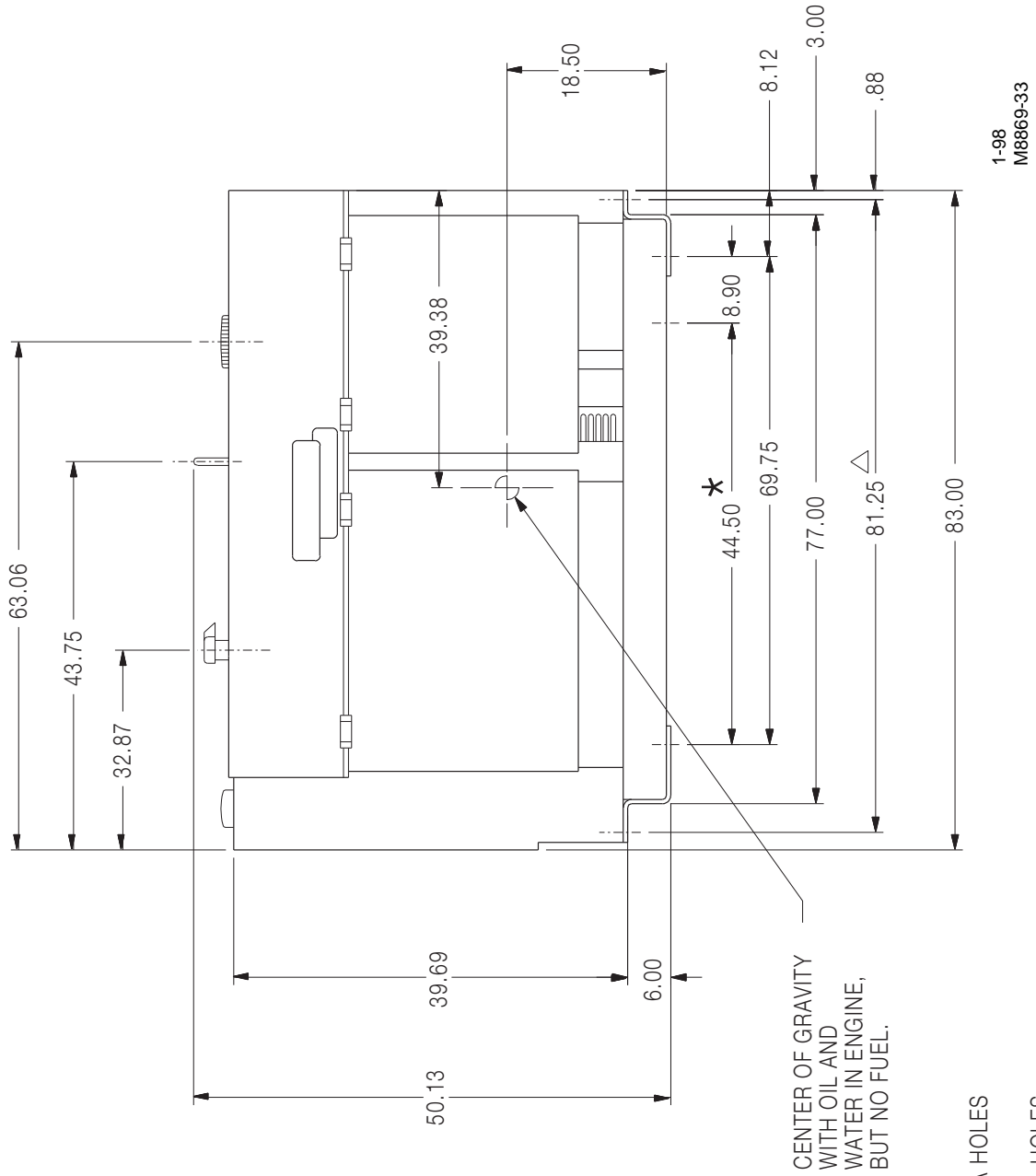

1-98
M8869-33

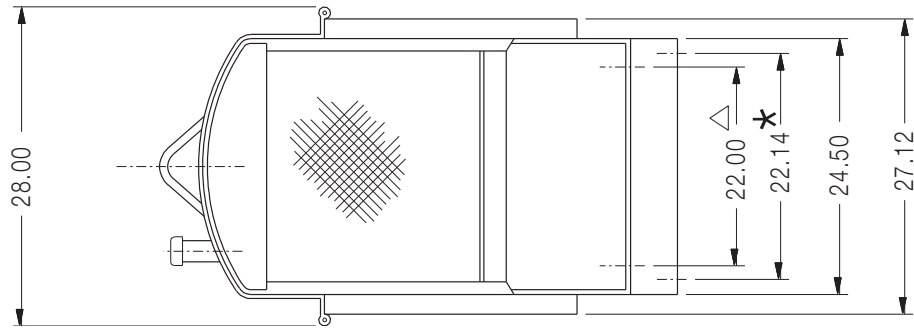

★ = .81 DIA HOLES
 △ = .69 DIA HOLES

SAE400 & SAE400 WELD'N AIR



NOTES

SAE400 & SAE400 WELD'N AIR



			
<ul style="list-style-type: none"> ● Keep your head out of fumes. ● Use ventilation or exhaust to remove fumes from breathing zone. 	<ul style="list-style-type: none"> ● Turn power off before servicing. 	<ul style="list-style-type: none"> ● Do not operate with panel open or guards off. 	WARNING
<ul style="list-style-type: none"> ● Los humos fuera de la zona de respiración. ● Mantenga la cabeza fuera de los humos. Utilice ventilación o aspiración para gases. 	<ul style="list-style-type: none"> ● Desconectar el cable de alimentación de poder de la máquina antes de iniciar cualquier servicio. 	<ul style="list-style-type: none"> ● No operar con panel abierto o guardas quitadas. 	Spanish AVISO DE PRECAUCION
<ul style="list-style-type: none"> ● Gardez la tête à l'écart des fumées. ● Utilisez un ventilateur ou un aspirateur pour ôter les fumées des zones de travail. 	<ul style="list-style-type: none"> ● Débranchez le courant avant l'entretien. 	<ul style="list-style-type: none"> ● N'opérez pas avec les panneaux ouverts ou avec les dispositifs de protection enlevés. 	French ATTENTION
<ul style="list-style-type: none"> ● Vermeiden Sie das Einatmen von Schweißrauch! ● Sorgen Sie für gute Be- und Entlüftung des Arbeitsplatzes! 	<ul style="list-style-type: none"> ● Strom vor Wartungsarbeiten abschalten! (Netzstrom völlig öffnen; Maschine anhalten!) 	<ul style="list-style-type: none"> ● Anlage nie ohne Schutzgehäuse oder Innenschutzverkleidung in Betrieb setzen! 	German WARNUNG
<ul style="list-style-type: none"> ● Mantenha seu rosto da fumaça. ● Use ventilação e exaustão para remover fumo da zona respiratória. 	<ul style="list-style-type: none"> ● Não opere com as tampas removidas. ● Desligue a corrente antes de fazer serviço. ● Não toque as partes elétricas nuas. 	<ul style="list-style-type: none"> ● Mantenha-se afastado das partes moventes. ● Não opere com os painéis abertos ou guardas removidas. 	Portuguese ATENÇÃO
<ul style="list-style-type: none"> ● ヒュームから頭を離すようにして下さい。 ● 換気や排煙に十分留意して下さい。 	<ul style="list-style-type: none"> ● メンテナンス・サービスに取りかかる際には、まず電源スイッチを必ず切って下さい。 	<ul style="list-style-type: none"> ● パネルやカバーを取り外したまま機械操作をしないで下さい。 	Japanese 注意事項
<ul style="list-style-type: none"> ● 頭部遠離煙霧。 ● 在呼吸區使用通風或排風器除煙。 	<ul style="list-style-type: none"> ● 維修前切斷電源。 	<ul style="list-style-type: none"> ● 儀表板打開或沒有安全罩時不準作業。 	Chinese 警告
<ul style="list-style-type: none"> ● 얼굴로부터 용접가스를 멀리하십시오. ● 호흡지역으로부터 용접가스를 제거하기 위해 가스제거기나 통풍기를 사용하십시오. 	<ul style="list-style-type: none"> ● 보수전에 전원을 차단하십시오. 	<ul style="list-style-type: none"> ● 판넬이 열린 상태로 작동치 마십시오. 	Korean 위험
<ul style="list-style-type: none"> ● ابعء رأسك بعيداً عن الدخان. ● استعمل التهوية أو جهاز ضغط الدخان للخارج لكي تبعد الدخان عن المنطقة التي تتنفس فيها. 	<ul style="list-style-type: none"> ● اقطع التيار الكهربائي قبل القيام بأية صيانة. 	<ul style="list-style-type: none"> ● لا تشغيل هذا الجهاز إذا كانت الاغطية الحديدية الواقية ليست عليه. 	Arabic تحذير

LEIA E COMPREENDA AS INSTRUÇÕES DO FABRICANTE PARA ESTE EQUIPAMENTO E AS PARTES DE USO, E SIGA AS PRÁTICAS DE SEGURANÇA DO EMPREGADOR.

使う機械や溶材のメーカーの指示書をよく読み、まず理解して下さい。そして貴社の安全規定に従って下さい。

請詳細閱讀並理解製造廠提供的說明以及應該使用的銀焊材料，並請遵守貴方的有關勞動保護規定。

이 제품에 동봉된 작업지침서를 숙지하시고 귀사의 작업자 안전수칙을 준수하시기 바랍니다.

اقرأ بتمعن وافهم تعليمات المصنع المنتج لهذه المعدات والمواد قبل استعمالها واتبع تعليمات الوقاية لصاحب العمل.

SAE400 & SAE400 WELD'N AIR



			
WARNING	<ul style="list-style-type: none"> ● Do not touch electrically live parts or electrode with skin or wet clothing. ● Insulate yourself from work and ground. 	<ul style="list-style-type: none"> ● Keep flammable materials away. 	<ul style="list-style-type: none"> ● Wear eye, ear and body protection.
Spanish AVISO DE PRECAUCION	<ul style="list-style-type: none"> ● No toque las partes o los electrodos bajo carga con la piel o ropa mojada. ● Aislese del trabajo y de la tierra. 	<ul style="list-style-type: none"> ● Mantenga el material combustible fuera del área de trabajo. 	<ul style="list-style-type: none"> ● Protéjase los ojos, los oídos y el cuerpo.
French ATTENTION	<ul style="list-style-type: none"> ● Ne laissez ni la peau ni des vêtements mouillés entrer en contact avec des pièces sous tension. ● Isolez-vous du travail et de la terre. 	<ul style="list-style-type: none"> ● Gardez à l'écart de tout matériel inflammable. 	<ul style="list-style-type: none"> ● Protégez vos yeux, vos oreilles et votre corps.
German WARNUNG	<ul style="list-style-type: none"> ● Berühren Sie keine stromführenden Teile oder Elektroden mit Ihrem Körper oder feuchter Kleidung! ● Isolieren Sie sich von den Elektroden und dem Erdboden! 	<ul style="list-style-type: none"> ● Entfernen Sie brennbares Material! 	<ul style="list-style-type: none"> ● Tragen Sie Augen-, Ohren- und Körperschutz!
Portuguese ATENÇÃO	<ul style="list-style-type: none"> ● Não toque partes elétricas e electrodos com a pele ou roupa molhada. ● Isole-se da peça e terra. 	<ul style="list-style-type: none"> ● Mantenha inflamáveis bem guardados. 	<ul style="list-style-type: none"> ● Use proteção para a vista, ouvido e corpo.
Japanese 注意事項	<ul style="list-style-type: none"> ● 通電中の電気部品、又は溶材にヒブやぬれた布で触れないこと。 ● 施工物やアースから身体が絶縁されている様にして下さい。 	<ul style="list-style-type: none"> ● 燃えやすいものの側での溶接作業は絶対にしてはなりません。 	<ul style="list-style-type: none"> ● 目、耳及び身体に保護具をして下さい。
Chinese 警告	<ul style="list-style-type: none"> ● 皮肤或湿衣物切勿接触带电部件及焊条。 ● 使你自已与地面和工件绝缘。 	<ul style="list-style-type: none"> ● 把一切易燃物品移离工作场所。 	<ul style="list-style-type: none"> ● 佩戴眼、耳及身体劳动保护用具。
Korean 위험	<ul style="list-style-type: none"> ● 전도체나 용접봉을 젖은 헝겍 또는 피부로 절대 접촉치 마십시오. ● 모재와 접지를 접촉치 마십시오. 	<ul style="list-style-type: none"> ● 인화성 물질을 접근 시키지 마십시오. 	<ul style="list-style-type: none"> ● 눈, 귀와 몸에 보호장구를 착용하십시오.
Arabic تحذير	<ul style="list-style-type: none"> ● لا تلمس الاجزاء التي يسري فيها التيار الكهربائي أو الإلكترود بجسد الجسم أو بالملابس المبللة بالماء. ● وضع عازلا على جسمك خلال العمل. 	<ul style="list-style-type: none"> ● ضع المواد القابلة للاشتعال في مكان بعيد. 	<ul style="list-style-type: none"> ● ضع أدوات وملابس واقية على عينيك وأذنيك وجسمك.

READ AND UNDERSTAND THE MANUFACTURER'S INSTRUCTION FOR THIS EQUIPMENT AND THE CONSUMABLES TO BE USED AND FOLLOW YOUR EMPLOYER'S SAFETY PRACTICES.

SE RECOMIENDA LEER Y ENTENDER LAS INSTRUCCIONES DEL FABRICANTE PARA EL USO DE ESTE EQUIPO Y LOS CONSUMIBLES QUE VA A UTILIZAR, SIGA LAS MEDIDAS DE SEGURIDAD DE SU SUPERVISOR.

LISEZ ET COMPRENEZ LES INSTRUCTIONS DU FABRICANT EN CE QUI REGARDE CET EQUIPMENT ET LES PRODUITS A ETRE EMPLOYES ET SUIVEZ LES PROCEDURES DE SECURITE DE VOTRE EMPLOYEUR.

LESEN SIE UND BEFOLGEN SIE DIE BETRIEBSANLEITUNG DER ANLAGE UND DEN ELEKTRODENEINSATZ DES HERSTELLERS. DIE UNFALLVERHÜTUNGSVORSCHRIFTEN DES ARBEITGEBERS SIND EBENFALLS ZU BEACHTEN.

SAE400 & SAE400 WELD'N AIR





• World's Leader in Welding and Cutting Products •

• Sales and Service through Subsidiaries and Distributors Worldwide •

Cleveland, Ohio 44117-1199 U.S.A. TEL: 216.481.8100 FAX: 216.486.1751 WEB SITE: www.lincolnelectric.com