

FLEXTEC 650 WIRING DIAGRAM G7148 REV: D

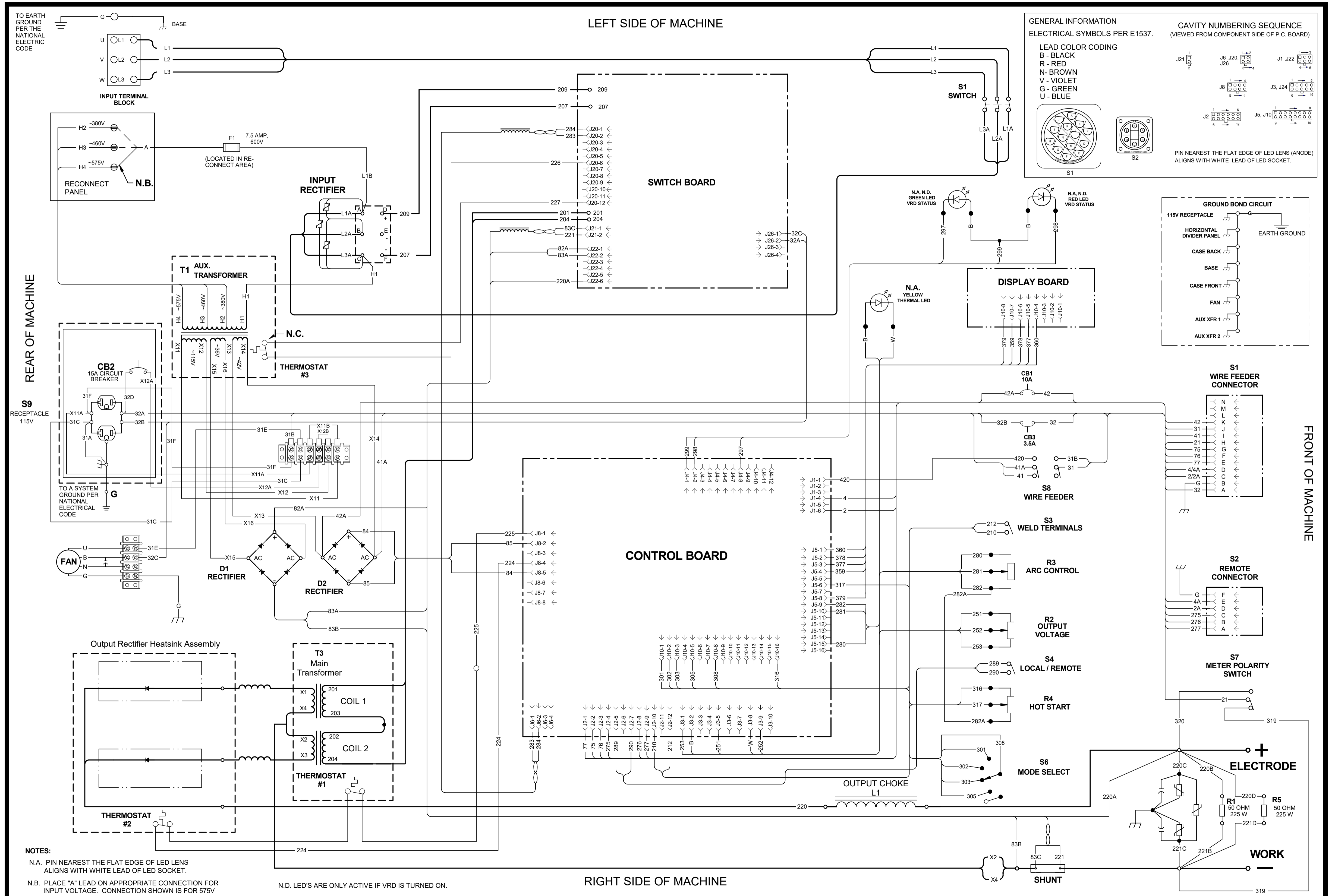

GENERAL INFORMATION
ELECTRICAL SYMBOLS PER E1537.

LEAD COLOR CODING
B - BLACK
R - RED
N - BROWN
V - VIOLET
G - GREEN
U - BLUE

CAVITY NUMBERING SEQUENCE
(VIEWED FROM COMPONENT SIDE OF P.C. BOARD)

PIN NEAREST THE FLAT EDGE OF LED LENS (ANODE) ALIGNS WITH WHITE LEAD OF LED SOCKET.

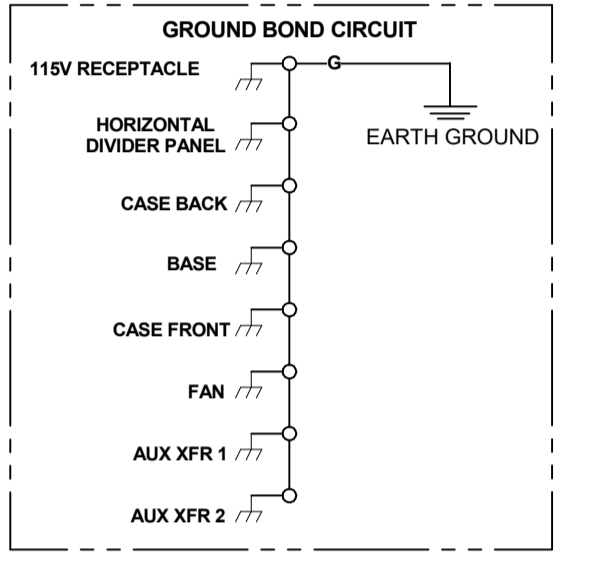

NOTES:

N.A. PIN NEAREST THE FLAT EDGE OF LED LENS ALIGNS WITH WHITE LEAD OF LED SOCKET.

N.B. PLACE "A" LEAD ON APPROPRIATE CONNECTION FOR INPUT VOLTAGE. CONNECTION SHOWN IS FOR 575V OPERATION.

N.C. THERMOSTAT 3 TURNS FAN ON BUT DOES NOT DISABLE WELDING OUTPUT OR SET THERMAL FAULT WHEN OPEN.

RIGHT SIDE OF MACHINE

