

FILCORD i250 & i300

Spare Parts	1
Figure A: Machine Assembly	2
Figure B: Inside Machine Assembly	3
Figure C: Front Assembly	4
Electrical Schematic	5
CODE: 50727, 50728	5



Spare Parts

SP50727, SP50728 REV05
09/2024

ASSEMBLY PAGE NAME			Machine Assembly	Machine Assembly	Machine Assembly	Miscellaneous Items		
CODE NO.:	W NO.:	FIGURE NO.:	A	B	C	-		
50727	W100000315	FILCORD i250	1	1	3	1		
50728	W100000316	FILCORD i300	2	2	4	2		

*items highlighted in bold are recommended spare parts

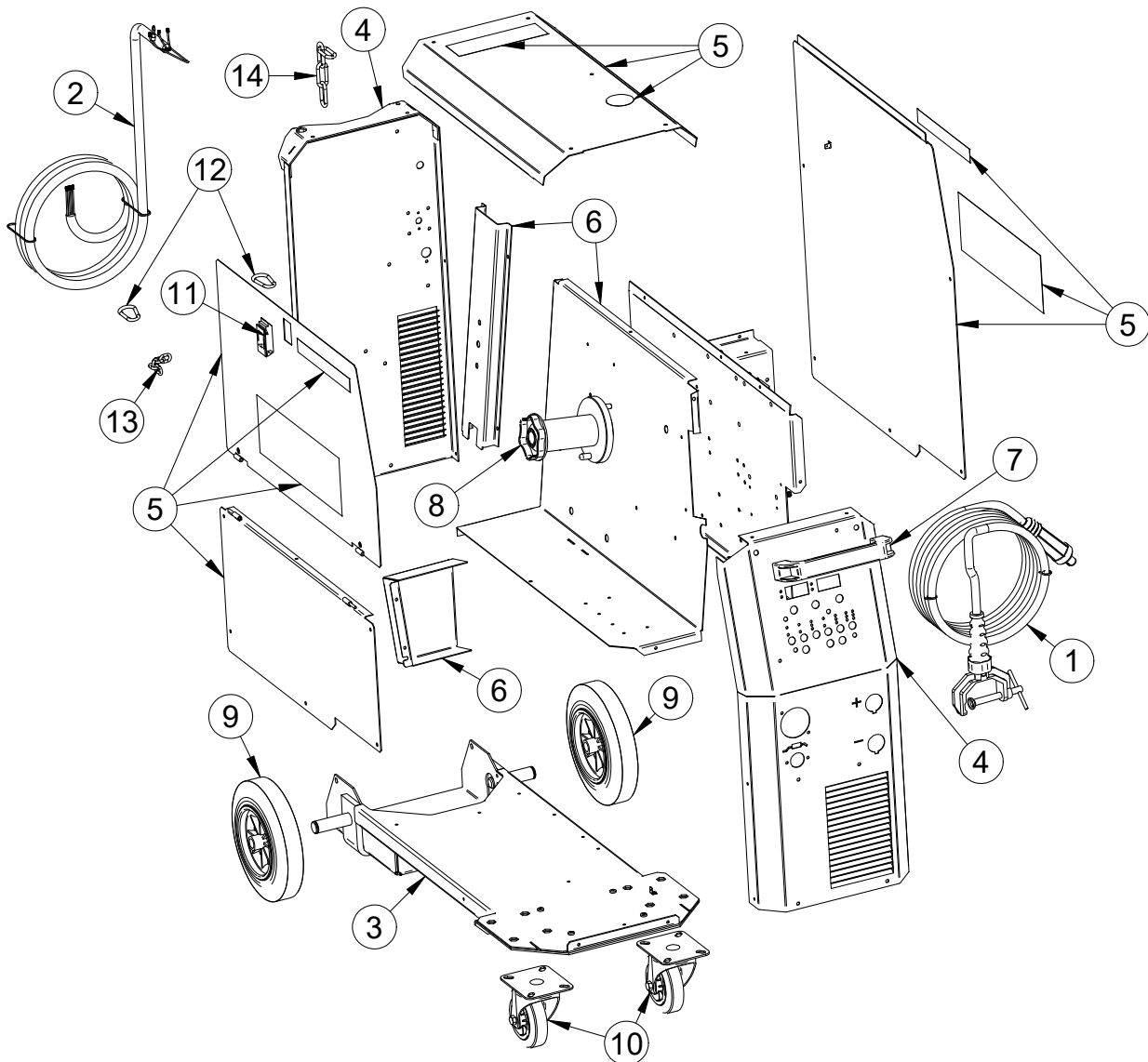

Figure A

Figure A: Machine Assembly

Item	Description	Part Number	QTY	1	2	3	4	5	6	7	
1	GROUND CABLE-3M-4	D-5578-176-4R	1	X	X						
2	MAIN INPUT CORD	R-5041-652-1R	1	X	X						
3	BASE ASSEMBLY	T-8040-148-1R	1	X	X						
4	FRONT AND REAR PANEL KIT	T-8040-149-1R	1	X	X						
5	SIDE PANEL KIT includes:	T-8040-150-2R	1	X	X						
	LEFT SIDE PANEL		1	X	X						
	UPPER SIDE PANEL		1	X	X						
	BOTTOM SIDE PANEL		1	X	X						
	TOP PLATE ASSEMBLY		1	X	X						
	FILCORD LABEL		2	X	X						
	SAF-FRO LABEL		2	X	X						
	LABEL		1	X	X						
	STICKER		1	X	X						
6	PARTITION KIT	T-8040-151-1R	1	X	X						
	PARTITION ASSEMBLY		1	X	X						
	BRACKET		1	X	X						
	COVER		1	X	X						
	LEXAN LABEL		1	X	X						
7	HANDLE BOTECA B226-180 M8	1361-598-186R	1	X	X						
8	WIRE SPOOL HUB	0744-000-335R	1	X	X						
9	WHEEL DIA-200	1029-660-201R	2	X	X						
10	TURNING WHEEL DIA-100	1029-660-101R	2	X	X						
11	DOOR LATCH PT,LF	0654-610-004R	1	X	X						
12	CLIP HOOK 5X50 K10347-PG	0652-410-006R	2	X	X						
13	CHAIN L=350MM	0652-410-004R	1	X	X						
14	CHAIN L=700MM	0652-410-003R	1	X	X						

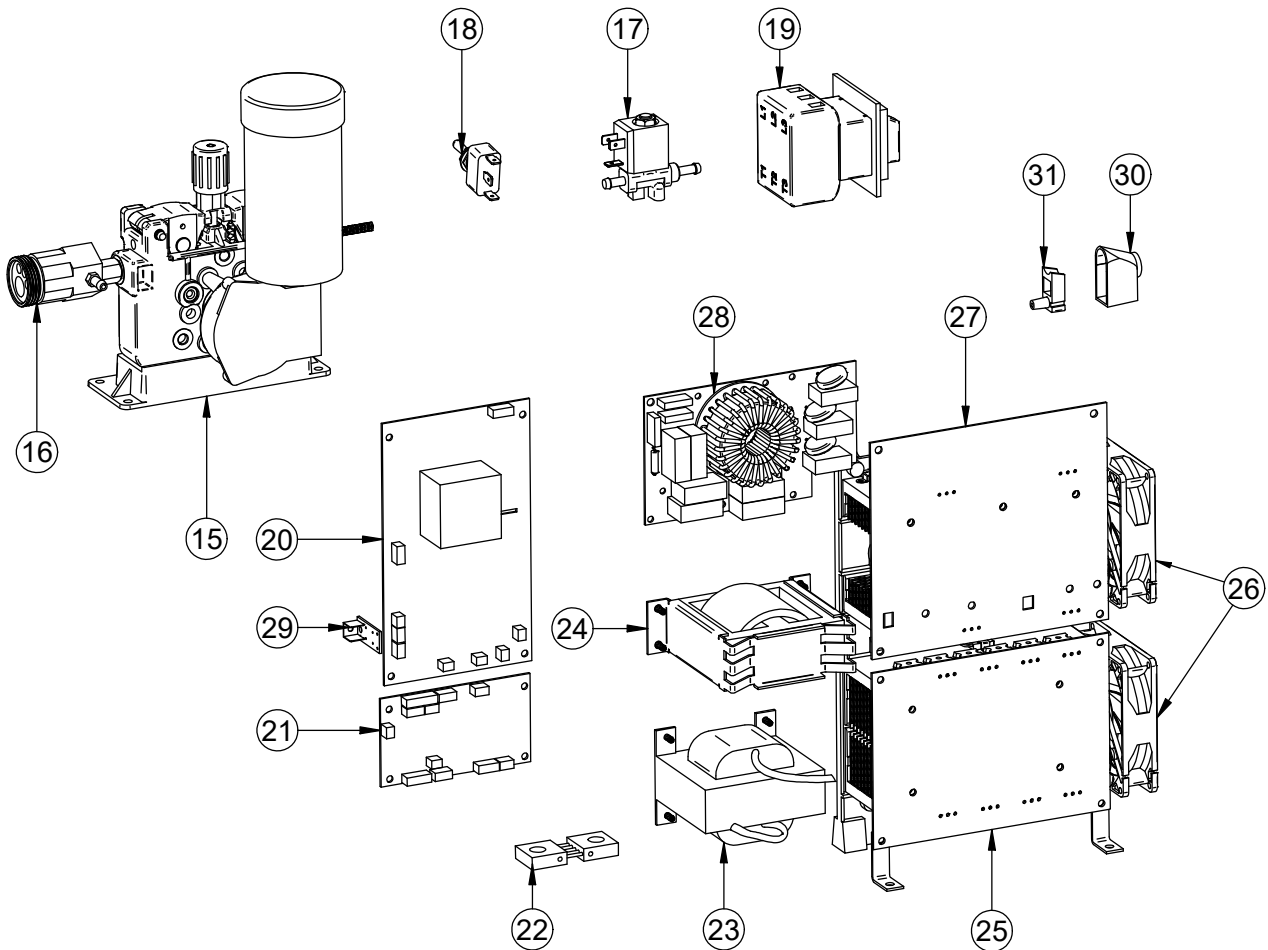

Figure B

Figure B: Inside Machine Assembly

Item	Description	Part Number	QTY	1	2	3	4	5	6	7
15	WIRE FEEDER ASSEMBLY (complete with Euro connector)	S33572-23	1	X	X					
16	EURO CONNECTOR ALONE	S33572-30	1	X	X					
17	GAS VALVE	S33572-24	1	X	X					
18	TOGGLE SWITCH HY29J	1115-280-004R	1	X	X					
19	SWITCH 400TPX, TH1538	W7511706R	1	X	X					
20	AUXILIARY POWER PCB	S33572-10	1	X	X					
21	CONTROL PCB	T-8040-172-1R	1	X						
	CONTROL PCB	T-8040-172-2R	1		X					
	CONTROL PCB	T-8040-172-3R	1			X				
	CONTROL PCB	T-8040-172-4R	1				X			
22	SHUNT	S33572-12	1	X	X					
23	CHOKE	S33572-13	1	X	X					
24	MAIN TRANSFORMER	S33572-14	1	X	X					
25	RECTIFICATION PCB	S33572-15	1	X	X					
26	FAN	S33572-16	2	X	X					
27	INVERTER PCB	S33572-17	1	X	X					
28	EMC FILTER	S33572-18	1	X	X					
29	SUPPRESSION PCB	S33572-19	1	X	X					
30	POWER CABLE GROMMET	1361-599-399R	1	X	X					
31	POWER CABLE CLAMP	1361-599-398R	1	X	X					

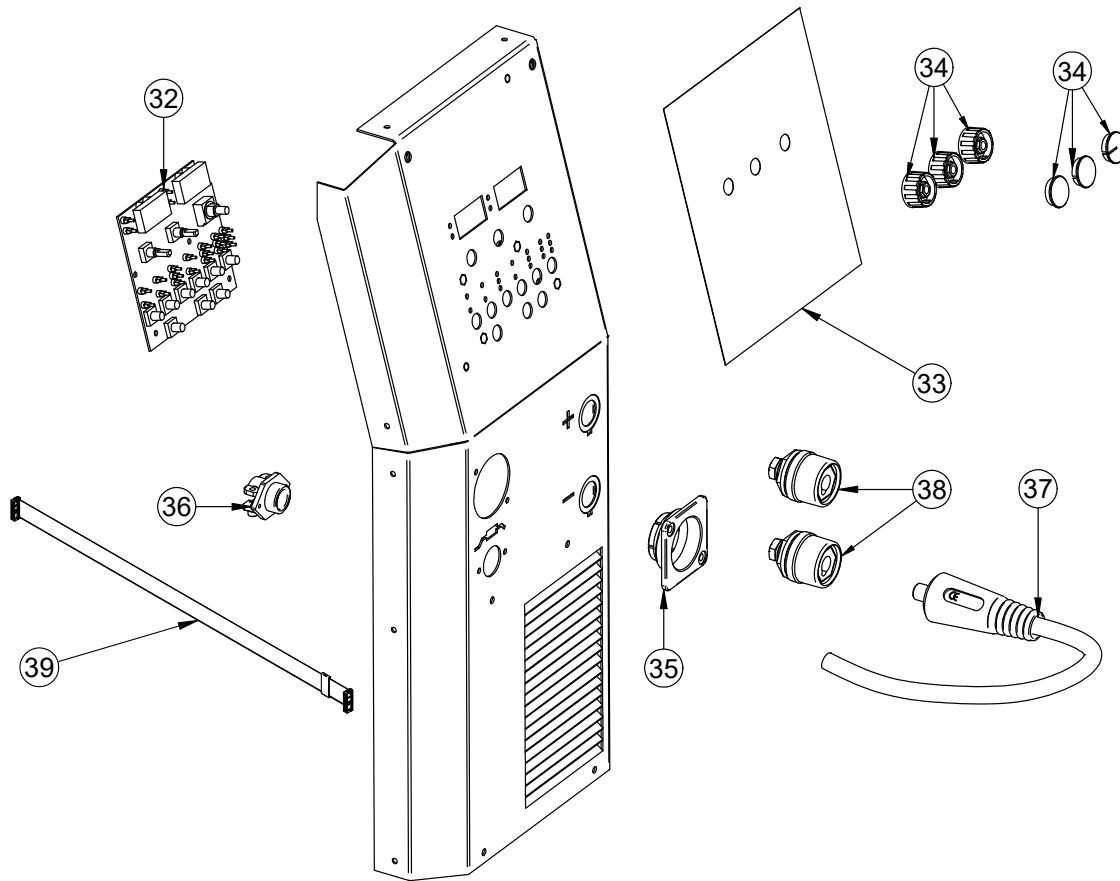

Figure C

Figure C: Front Assembly

Item	Description	Part Number	QTY	1	2	3	4	5	6	7
32	USER INTERFACE PCB	S33572-25	1	X	X					
	USER INTERFACE PCB	S33572-33	1			X	X			
33	FRONT PANEL LABEL	R-0000-372-1R	1	X		X				
	FRONT PANEL LABEL	R-0000-371-1R	1		X		X			
34	HOOD AND KNOB SET include:	T-8040-153-2R	1	X	X	X	X			
	KNOB D28		3	X	X	X	X			
	BLUE HOOD D = 29		2	X	X	X	X			
	CAP D28 BLUE + WHITE LINE		1	X	X	X	X			
35	COVER EURO	0646-231-005R	1	X	X	X	X			
36	STRAIN RELIEF	1361-599-674R	1	X	X	X	X			
37	POLARITY CHANGE HARNESS	T-5041-005-1R	1	X	X	X	X			
38	SOCKET X2, X3, X4	90000595PR	2	X	X	X	X			
39	HARNESS-DISPLAY TO CONTROL BOARD	S33572-34	1	X	X	X	X			

Electrical Schematic

CODE: 50727, 50728

