

POWER MIG 216 MACHINE SCHEMATIC L15080 REV: B

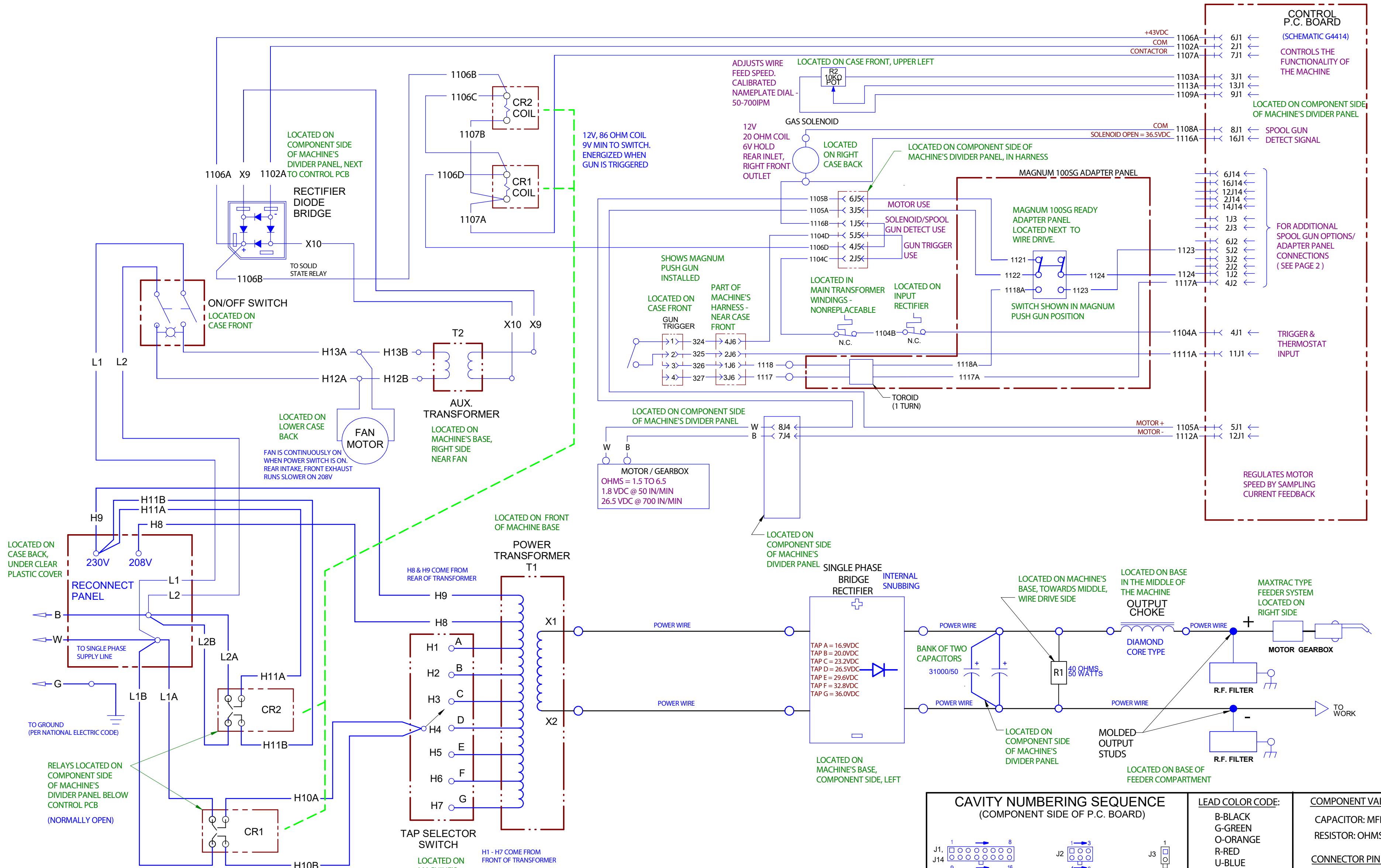

CAVITY NUMBERING SEQUENCE (COMPONENT SIDE OF P.C. BOARD)	LEAD COLOR CODE:	COMPONENT VALUE UNITS:
<p>(NON-LEAD SIDE OF CONNECTOR)</p>	B-BLACK G-GREEN O-ORANGE R-RED U-BLUE W-WHITE Y-YELLOW	CAPACITOR: MFD/VOLTS RESISTOR: OHMS/WATTS CONNECTOR PIN NUMBERS: EX. 12 PIN CONNECTOR

MACHINE SCHEMATIC L15080 REV: B PAGE 2

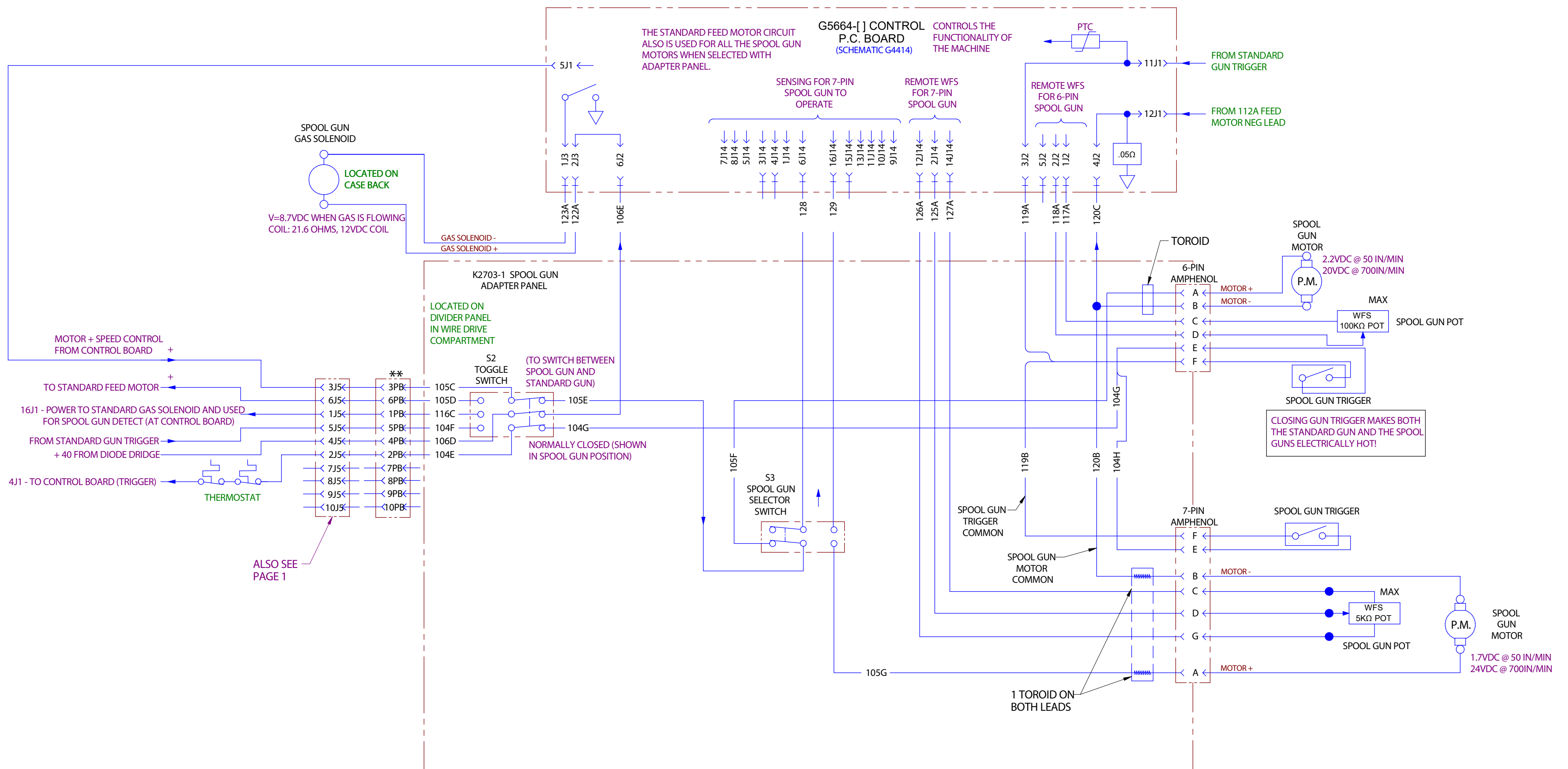

FOR MAGNUM SG AND MAGNUM 250LX
 ** SPOOL GUNS OPERATION, REMOVE
 MAGNUM 100SG ADAPTER PANEL (AND
 HARNESS / SWITCH) FROM P5 OF MACHINE
 HARNESS AND PLUG IN K2703-1 SPOOL GUN
 HARNESS

REFER TO L1 1543-2 FOR SPOOL GUN
 ADAPTER PANEL INSTALLATION
 INSTRUCTIONS.

CAVITY NUMBERING SEQUENCE (COMPONENT SIDE OF P.C. BOARD)

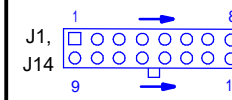

(NON-LEAD SIDE OF CONNECTOR)

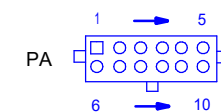

LEAD COLOR CODE:

- B-BLACK
- G-GREEN
- O-ORANGE
- R-RED
- U-BLUE
- W-WHITE
- Y-YELLOW

LABELS:

- COMMON
- FRAME GROUND
- EARTH GROUND

COMPONENT VALUE UNITS:

- CAPACITOR: MFD/VOLTS
- RESISTOR: OHMS/WATTS

CONNECTOR PIN NUMBERS:

EX. 12 PIN CONNECTOR

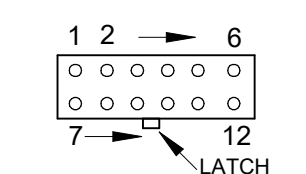

VIEW OF CONNECTOR ON PC BOARD