

Operator's Manual

DLF-72[®]

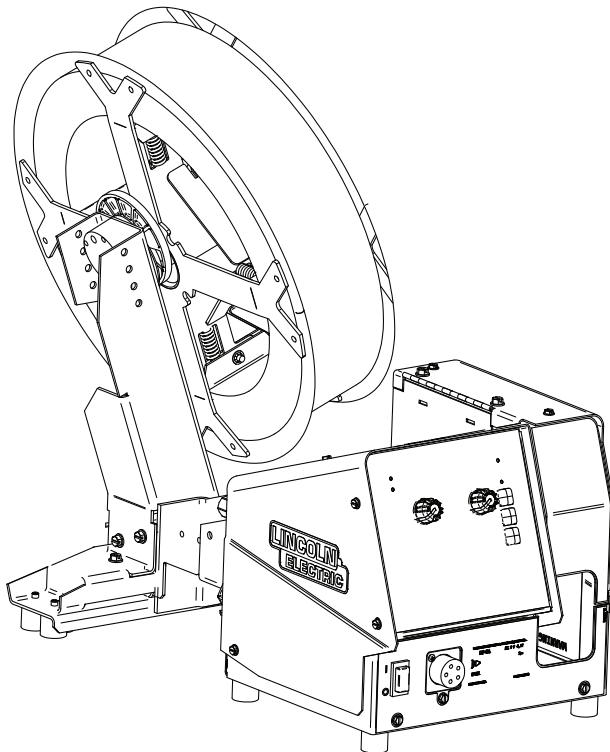

For use with machines having Code Numbers:

13237, 13238, 13239



Register your machine:

www.lincolnelectric.com/register

Authorized Service and Distributor Locator:

www.lincolnelectric.com/locator

Save for future reference

Date Purchased

Code: (ex: 10859)

Serial: (ex: U1060512345)

Need Help? Call 1.888.935.3877

to talk to a Service Representative

Hours of Operation:

8:00 AM to 6:00 PM (ET) Mon. thru Fri.

After hours?

Use "Ask the Experts" at lincolnelectric.com

A Lincoln Service Representative will contact you no later than the following business day.

For Service outside the USA:

Email: globalservice@lincolnelectric.com

THANK YOU FOR SELECTING A QUALITY PRODUCT BY LINCOLN ELECTRIC.

PLEASE EXAMINE CARTON AND EQUIPMENT FOR DAMAGE IMMEDIATELY

When this equipment is shipped, title passes to the purchaser upon receipt by the carrier. Consequently, claims for material damaged in shipment must be made by the purchaser against the transportation company at the time the shipment is received.

SAFETY DEPENDS ON YOU

Lincoln arc welding and cutting equipment is designed and built with safety in mind. However, your overall safety can be increased by proper installation ... and thoughtful operation on your part. **DO NOT INSTALL, OPERATE OR REPAIR THIS EQUIPMENT WITHOUT READING THIS MANUAL AND THE SAFETY PRECAUTIONS CONTAINED THROUGHOUT.** And, most importantly, think before you act and be careful.

WARNING

This statement appears where the information must be followed exactly to avoid serious personal injury or loss of life.

CAUTION

This statement appears where the information must be followed to avoid minor personal injury or damage to this equipment.



KEEP YOUR HEAD OUT OF THE FUMES.

DON'T get too close to the arc. Use corrective lenses if necessary to stay a reasonable distance away from the arc.

READ and obey the Safety Data Sheet (SDS) and the warning label that appears on all containers of welding materials.

USE ENOUGH VENTILATION or exhaust at the arc, or both, to keep the fumes and gases from your breathing zone and the general area.

IN A LARGE ROOM OR OUTDOORS, natural ventilation may be adequate if you keep your head out of the fumes (See below).

USE NATURAL DRAFTS or fans to keep the fumes away from your face.

If you develop unusual symptoms, see your supervisor. Perhaps the welding atmosphere and ventilation system should be checked.

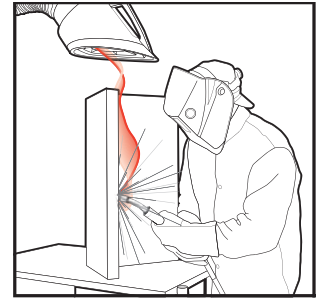

WEAR CORRECT EYE, EAR & BODY PROTECTION

PROTECT your eyes and face with welding helmet properly fitted and with proper grade of filter plate (See ANSI Z49.1).

PROTECT your body from welding spatter and arc flash with protective clothing including woolen clothing, flame-proof apron and gloves, leather leggings, and high boots.

PROTECT others from splatter, flash, and glare with protective screens or barriers.

IN SOME AREAS, protection from noise may be appropriate.

BE SURE protective equipment is in good condition.

Also, wear safety glasses in work area **AT ALL TIMES.**



SPECIAL SITUATIONS

DO NOT WELD OR CUT containers or materials which previously had been in contact with hazardous substances unless they are properly cleaned. This is extremely dangerous.

DO NOT WELD OR CUT painted or plated parts unless special precautions with ventilation have been taken. They can release highly toxic fumes or gases.

Additional precautionary measures

PROTECT compressed gas cylinders from excessive heat, mechanical shocks, and arcs; fasten cylinders so they cannot fall.

BE SURE cylinders are never grounded or part of an electrical circuit.

REMOVE all potential fire hazards from welding area.

ALWAYS HAVE FIRE FIGHTING EQUIPMENT READY FOR IMMEDIATE USE AND KNOW HOW TO USE IT.



SECTION A: WARNINGS



CALIFORNIA PROPOSITION 65 WARNINGS



WARNING: Breathing diesel engine exhaust exposes you to chemicals known to the State of California to cause cancer and birth defects, or other reproductive harm.

- Always start and operate the engine in a well-ventilated area.
- If in an exposed area, vent the exhaust to the outside.
- Do not modify or tamper with the exhaust system.
- Do not idle the engine except as necessary.

For more information go to www.P65warnings.ca.gov/diesel

WARNING: This product, when used for welding or cutting, produces fumes or gases which contain chemicals known to the State of California to cause birth defects and, in some cases, cancer. (California Health & Safety Code § 25249.5 *et seq.*)



WARNING: Cancer and Reproductive Harm
www.P65warnings.ca.gov

ARC WELDING CAN BE HAZARDOUS. PROTECT YOURSELF AND OTHERS FROM POSSIBLE SERIOUS INJURY OR DEATH. KEEP CHILDREN AWAY. PACEMAKER WEARERS SHOULD CONSULT WITH THEIR DOCTOR BEFORE OPERATING.

Read and understand the following safety highlights. For additional safety information, it is strongly recommended that you purchase a copy of "Safety in Welding & Cutting - ANSI Standard Z49.1" from the American Welding Society, P.O. Box 351040, Miami, Florida 33135 or CSA Standard W117.2. A Free copy of "Arc Welding Safety" booklet E205 is available from the Lincoln Electric Company, 22801 St. Clair Avenue, Cleveland, Ohio 44117-1199.

BE SURE THAT ALL INSTALLATION, OPERATION, MAINTENANCE AND REPAIR PROCEDURES ARE PERFORMED ONLY BY QUALIFIED INDIVIDUALS.



FOR ENGINE POWERED EQUIPMENT.

- Turn the engine off before troubleshooting and maintenance work unless the maintenance work requires it to be running.
- Operate engines in open, well-ventilated areas or vent the engine exhaust fumes outdoors.
- Do not add the fuel near an open flame welding arc or when the engine is running. Stop the engine and allow it to cool before refueling to prevent spilled fuel from vaporizing on contact



with hot engine parts and igniting. Do not spill fuel when filling tank. If fuel is spilled, wipe it up and do not start engine until fumes have been eliminated.

- Keep all equipment safety guards, covers and devices in position and in good repair. Keep hands, hair, clothing and tools away from V-belts, gears, fans and all other moving parts when starting, operating or repairing equipment.
- In some cases it may be necessary to remove safety guards to perform required maintenance. Remove guards only when necessary and replace them when the maintenance requiring their removal is complete. Always use the greatest care when working near moving parts.
- Do not put your hands near the engine fan. Do not attempt to override the governor or idler by pushing on the throttle control rods while the engine is running.
- To prevent accidentally starting gasoline engines while turning the engine or welding generator during maintenance work, disconnect the spark plug wires, distributor cap or magneto wire as appropriate.
- To avoid scalding, do not remove the radiator pressure cap when the engine is hot.
- Using a generator indoors CAN KILL YOU IN MINUTES.
- Generator exhaust contains carbon monoxide. This is a poison you cannot see or smell.
- NEVER use inside a home or garage, EVEN IF doors and windows are open.
- Only use OUTSIDE and far away from windows, doors and vents.
- Avoid other generator hazards. READ MANUAL BEFORE USE.



ELECTRIC AND MAGNETIC FIELDS MAY BE DANGEROUS



- Electric current flowing through any conductor causes localized Electric and Magnetic Fields (EMF). Welding current creates EMF fields around welding cables and welding machines
- EMF fields may interfere with some pacemakers, and welders having a pacemaker should consult their physician before welding.
- Exposure to EMF fields in welding may have other health effects which are now not known.
- All welders should use the following procedures in order to minimize exposure to EMF fields from the welding circuit:
 - Route the electrode and work cables together - Secure them with tape when possible.
 - Never coil the electrode lead around your body.
 - Do not place your body between the electrode and work cables. If the electrode cable is on your right side, the work cable should also be on your right side.
 - Connect the work cable to the workpiece as close as possible to the area being welded.
 - Do not work next to welding power source.



ELECTRIC SHOCK CAN KILL.



- 3.a. The electrode and work (or ground) circuits are electrically “hot” when the welder is on. Do not touch these “hot” parts with your bare skin or wet clothing. Wear dry, hole-free gloves to insulate hands.
- 3.b. Insulate yourself from work and ground using dry insulation. Make certain the insulation is large enough to cover your full area of physical contact with work and ground.

In addition to the normal safety precautions, if welding must be performed under electrically hazardous conditions (in damp locations or while wearing wet clothing; on metal structures such as floors, gratings or scaffolds; when in cramped positions such as sitting, kneeling or lying, if there is a high risk of unavoidable or accidental contact with the workpiece or ground) use the following equipment:

- Semiautomatic DC Constant Voltage (Wire) Welder.
 - DC Manual (Stick) Welder.
 - AC Welder with Reduced Voltage Control.
- 3.c. In semiautomatic or automatic wire welding, the electrode, electrode reel, welding head, nozzle or semiautomatic welding gun are also electrically “hot”.
 - 3.d. Always be sure the work cable makes a good electrical connection with the metal being welded. The connection should be as close as possible to the area being welded.
 - 3.e. Ground the work or metal to be welded to a good electrical (earth) ground.
 - 3.f. Maintain the electrode holder, work clamp, welding cable and welding machine in good, safe operating condition. Replace damaged insulation.
 - 3.g. Never dip the electrode in water for cooling.
 - 3.h. Never simultaneously touch electrically “hot” parts of electrode holders connected to two welders because voltage between the two can be the total of the open circuit voltage of both welders.
 - 3.i. When working above floor level, use a safety belt to protect yourself from a fall should you get a shock.
 - 3.j. Also see Items 6.c. and 8.



ARC RAYS CAN BURN.



- 4.a. Use a shield with the proper filter and cover plates to protect your eyes from sparks and the rays of the arc when welding or observing open arc welding. Headshield and filter lens should conform to ANSI Z87.1 standards.
- 4.b. Use suitable clothing made from durable flame-resistant material to protect your skin and that of your helpers from the arc rays.
- 4.c. Protect other nearby personnel with suitable, non-flammable screening and/or warn them not to watch the arc nor expose themselves to the arc rays or to hot spatter or metal.



FUMES AND GASES CAN BE DANGEROUS.



- 5.a. Welding may produce fumes and gases hazardous to health. Avoid breathing these fumes and gases. When welding, keep your head out of the fume. Use enough ventilation and/or exhaust at the arc to keep fumes and gases away from the breathing zone. **When welding hardfacing (see instructions on container or SDS) or on lead or cadmium plated steel and other metals or coatings which produce highly toxic fumes, keep exposure as low as possible and within applicable OSHA PEL and ACGIH TLV limits using local exhaust or mechanical ventilation unless exposure assessments indicate otherwise. In confined spaces or in some circumstances, outdoors, a respirator may also be required. Additional precautions are also required when welding on galvanized steel.**
- 5.b. The operation of welding fume control equipment is affected by various factors including proper use and positioning of the equipment, maintenance of the equipment and the specific welding procedure and application involved. Worker exposure level should be checked upon installation and periodically thereafter to be certain it is within applicable OSHA PEL and ACGIH TLV limits.
- 5.c. Do not weld in locations near chlorinated hydrocarbon vapors coming from degreasing, cleaning or spraying operations. The heat and rays of the arc can react with solvent vapors to form phosgene, a highly toxic gas, and other irritating products.
- 5.d. Shielding gases used for arc welding can displace air and cause injury or death. Always use enough ventilation, especially in confined areas, to insure breathing air is safe.
- 5.e. Read and understand the manufacturer’s instructions for this equipment and the consumables to be used, including the Safety Data Sheet (SDS) and follow your employer’s safety practices. SDS forms are available from your welding distributor or from the manufacturer.
- 5.f. Also see item 1.b.



WELDING AND CUTTING SPARKS CAN CAUSE FIRE OR EXPLOSION.

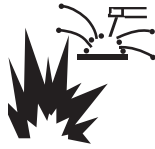

- 6.a. Remove fire hazards from the welding area. If this is not possible, cover them to prevent the welding sparks from starting a fire. Remember that welding sparks and hot materials from welding can easily go through small cracks and openings to adjacent areas. Avoid welding near hydraulic lines. Have a fire extinguisher readily available.
- 6.b. Where compressed gases are to be used at the job site, special precautions should be used to prevent hazardous situations. Refer to "Safety in Welding and Cutting" (ANSI Standard Z49.1) and the operating information for the equipment being used.
- 6.c. When not welding, make certain no part of the electrode circuit is touching the work or ground. Accidental contact can cause overheating and create a fire hazard.
- 6.d. Do not heat, cut or weld tanks, drums or containers until the proper steps have been taken to insure that such procedures will not cause flammable or toxic vapors from substances inside. They can cause an explosion even though they have been "cleaned". For information, purchase "Recommended Safe Practices for the Preparation for Welding and Cutting of Containers and Piping That Have Held Hazardous Substances", AWS F4.1 from the American Welding Society (see address above).
- 6.e. Vent hollow castings or containers before heating, cutting or welding. They may explode.
- 6.f. Sparks and spatter are thrown from the welding arc. Wear oil free protective garments such as leather gloves, heavy shirt, cuffless trousers, high shoes and a cap over your hair. Wear ear plugs when welding out of position or in confined places. Always wear safety glasses with side shields when in a welding area.
- 6.g. Connect the work cable to the work as close to the welding area as practical. Work cables connected to the building framework or other locations away from the welding area increase the possibility of the welding current passing through lifting chains, crane cables or other alternate circuits. This can create fire hazards or overheat lifting chains or cables until they fail.
- 6.h. Also see item 1.c.
- 6.i. Read and follow NFPA 51B "Standard for Fire Prevention During Welding, Cutting and Other Hot Work", available from NFPA, 1 Batterymarch Park, PO box 9101, Quincy, MA 022690-9101.
- 6.j. Do not use a welding power source for pipe thawing.



CYLINDER MAY EXPLODE IF DAMAGED.



- 7.a. Use only compressed gas cylinders containing the correct shielding gas for the process used and properly operating regulators designed for the gas and pressure used. All hoses, fittings, etc. should be suitable for the application and maintained in good condition.
- 7.b. Always keep cylinders in an upright position securely chained to an undercarriage or fixed support.
- 7.c. Cylinders should be located:
 - Away from areas where they may be struck or subjected to physical damage.
 - A safe distance from arc welding or cutting operations and any other source of heat, sparks, or flame.
- 7.d. Never allow the electrode, electrode holder or any other electrically "hot" parts to touch a cylinder.
- 7.e. Keep your head and face away from the cylinder valve outlet when opening the cylinder valve.
- 7.f. Valve protection caps should always be in place and hand tight except when the cylinder is in use or connected for use.
- 7.g. Read and follow the instructions on compressed gas cylinders, associated equipment, and CGA publication P-1, "Precautions for Safe Handling of Compressed Gases in Cylinders," available from the Compressed Gas Association, 14501 George Carter Way Chantilly, VA 20151.



FOR ELECTRICALLY POWERED EQUIPMENT.



- 8.a. Turn off input power using the disconnect switch at the fuse box before working on the equipment.
- 8.b. Install equipment in accordance with the U.S. National Electrical Code, all local codes and the manufacturer's recommendations.
- 8.c. Ground the equipment in accordance with the U.S. National Electrical Code and the manufacturer's recommendations.

Refer to
<http://www.lincolnelectric.com/safety>
for additional safety information.

| | |
|--|----------------------------------|
| GENERAL DESCRIPTION | 3 |
| RECOMMENDED PROCESSES..... | 3 |
| PROCESS LIMITATIONS..... | 3 |
| EQUIPMENT LIMITATIONS | 3 |
| RECOMMENDED POWER SOURCES | 3 |
| OTHER POWER SOURCES..... | 3 |
| DESIGN FEATURES..... | 3 |
| INSTALLATION | SECTION A |
| LOCATION | A-1 |
| TECHNICAL SPECIFICATIONS | A-2 |
| RECOMMENDED ELECTRODE AND WORK CABLE SIZES FOR ARC WELDING | A-3 |
| TRIGGER CONNECTOR..... | A-3 |
| PROCEDURE TO INSTALL DRIVE ROLLS AND WIRE GUIDES | A-4 |
| PRESSURE ARM ADJUSTMENT..... | A-4 |
| CHANGING THE GUN ADAPTER BUSHING | A-5 |
| GUN CONNECTION..... | A-6 |
| SHIELDING GAS CONNECTION | A-6 |
| OPERATION | SECTION B |
| POWER-UP SEQUENCE..... | B-1 |
| CONNECTION DIAGRAM..... | B-2 |
| DEFINITION OF WELDING TERMS..... | B-3 |
| ACROSS THE ARC SETUP WITH CROSSLINC™..... | B-2 |
| DIGITAL METER DISPLAY | B-4 |
| SETTINGS MENU..... | B-5 |
| CASE FRONT CONTROLS | B-6 |
| INTERNAL CONTROLS | B-7 |
| REAR CONNECTIONS..... | B-8 |
| OPTIONS/ACCESSORIES..... | SECTION C |
| MAINTENANCE | SECTION D |
| ROUTINE MAINTENANCE | D-1 |
| PERIODIC MAINTENANCE | D-1 |
| TROUBLESHOOTING | SECTION E |
| DIAGRAMS | SECTION F |
| PARTS LIST | PARTS.LINCOLNELECTRIC.COM |

CONTENT/DETAILS MAY BE CHANGED OR UPDATED WITHOUT NOTICE. FOR MOST CURRENT INSTRUCTION MANUALS, GO TO PARTS.LINCOLNELECTRIC.COM.

GENERAL DESCRIPTION

The DLF-72 is a light-weight, portable, ArcLink® enabled feeder. The DLF-72 has been designed for benchtop use in heavy industrial fabrication and job shops. This reliable, industrial feeder is ideal for MIG, flux cored, and metal cored wire welding applications. It can also accommodate up to a 60 lb. spool or direct feed from a bulk wire package.

The DLF-72 comes factory equipped with a K3345-1 Magnum® Tweco-compatible style #2-#4 gun adapter. Other gun adapters are available as field installed options to accommodate different style guns.

In addition to ArcLink®, the DLF-72 wire feeder has the following features:

- Rating - 600 amp, 60% duty cycle rating.
- 0.023 - 1/16" (0.6 - 1.59mm) GMAW Wire Diameters.
- 0.035 - 5/64" (0.9 - 1.59mm) FCAW Wire Diameters.
- Gas apparatus - can be used for FCAW and GMAW processes.
- The OLED Display allows for simple process navigation and pulse weld mode selection.
- The heart of the DLF-72 is the 2 roll MAXTRAC® drive. The patented features on the wire drive offer tool-less changing of the drive rolls and wire guides for quick spool changes. A tachometer controlled motor powers the patented drive rolls for smooth, steady feeding without slippage.

RECOMMENDED PROCESSES

- GMAW
- FCAW

PROCESS LIMITATIONS

- Does not support CC mode operation.

EQUIPMENT LIMITATIONS

RECOMMENDED POWER SOURCES

- Flextecs

OTHER POWER SOURCES

- ArcLink® Enabled Vantages

DESIGN FEATURES**Loaded with Standard Features Controls**

- Large Digital Displays with dedicated voltage and wire feed speed knobs.
- Presettable voltage and wire feed speed.
- Electronic Trigger interlock for comfort when making long welds.
- Cold-feed button for wire feeding without activating welding output.
- Gas Purge button for purging the gas path without activating welding output.
- Supports external Dual Procedure Selection Switch.
- The following options are available from the setup menu:
 - Variable run-in speed for smoother arc starting.
 - Burnback time provides adjustable power source output shutoff to prevent the electrode from sticking in the crater.
 - Preflow and Postflow ensures proper gas shielding coverage before and after each weld.

READ ENTIRE INSTALLATION SECTION BEFORE
INSTALLING THE DLF-72.

INSTALLATION

WARNING

ELECTRIC SHOCK CAN KILL.

- Turn the input power OFF at the disconnect switch or fuse box before attempting to connect or disconnect input power lines, output cables or control cables.
- Only qualified personnel should perform this installation.



SELECT SUITABLE LOCATION

For best wire feeding performance, place the DLF-72 on a stable and dry surface. Keep the wire feeder in a vertical position. Do not operate the wire feeder on an angled surface of more than 15 degrees.

Do not submerge the DLF-72.

The DLF-72 is rated IP2x and is suitable for indoor use.

When suspending a wire feeder, use the intended lift bale to ensure insulation from the hanging device.

Do not place bench models on inclined plane of more than 15 degrees from horizontal for risk of toppling over.

The EMC or RF classification of this equipment is Class A of IEC 60974-10.

CAUTION

High Frequency Interference Protection

Locate the DLF-72 away from radio controlled machinery. The normal operation of the DLF-72 may adversely affect the operation of the RF controlled equipment, which may result in bodily injury or damage to the equipment.

LOADING SPOOLS AND COILS

WARNING

- Keep hands, hair, clothing and tools away from rotating equipment.
- Do not wear gloves when threading wire or changing wire spool.
- Only qualified personnel should install, use or service this equipment.

TECHNICAL SPECIFICATIONS -

| MODEL SUMMARY | | | | |
|----------------------|-----------------------------|---------------|--------------------------------|---|
| K# | Description | Meters | Drive Roll Kit Included | Feed Plate Gun Adapter Installed |
| K5280-1 | DLF-72 | DIGITAL | .035/.045 Spur | K3345-1 |
| K5280-2 | DLF-72 Bench Model | DIGITAL | .035/.045 Spur | K3345-1 |
| K5280-3 | DLF-72 Bench Model with Gun | DIGITAL | .035/.045 Spur | K3345-1 |

| INPUT - SINGLE PHASE | |
|----------------------------------|-------------------------------------|
| Input Voltage +/- 10% | Input Amperes @ Rated Output |
| 40V DC | 6A |
| RATED OUTPUT (ALL MODELS) | |
| Duty Cycle | Amperes |
| 60% | 600A |

| PHYSICAL DIMENSIONS | | | | |
|----------------------------|-----------------------|-----------------------|-----------------------|---------------|
| Model | Height | Width | Depth | Weight |
| K5280-1 | 12 in. (305 mm) | 11.25 in. (286 mm) | 11.5 in. (292 mm) | 33 lbs. |
| K5280-2 | 15.65 in. (398 mm) | 12 in. (305 mm) | 24.57 in. (624 mm) | 32.5 lbs. |

| TEMPERATURE RANGES | |
|------------------------------------|----------------------------------|
| OPERATING TEMPERATURE RANGE | STORAGE TEMPERATURE RANGE |
| -14°F to 104°F (-10°C to 40°C) | -40°F to 122°F (-40°C to 50°C) |

Thermal tests have been performed at ambient temperature.

| PROCESS | WIRE DIAMETER RANGE | WIRE FEED SPEED RANGE |
|----------------|------------------------------|----------------------------------|
| GMAW | 0.023 - 1/16" (0.6 - 1.59mm) | 40 - 800 IPM (1 - 20.3 m/minute) |
| FCAW | 0.035 - 5/64" (0.9 - 1.59mm) | |

RECOMMENDED ELECTRODE AND WORK CABLE SIZES FOR ARC WELDING

(See Table A.1)

Tabulated below are copper cable sizes recommended for different currents and duty cycles. Lengths stipulated are the distance from the welder through work and back to the welder again. Cable sizes are increased for greater lengths primarily for the purpose of minimizing cable drop.

TABLE A.1

| RECOMMENDED CABLE SIZES (RUBBER COVERED COPPER - RATED 167°F OR 75°C)** | | | | | | |
|--|---------------------------|--|-------------------------------------|---------------------------------------|---------------------------------------|---------------------------------------|
| Amperes | PERCENT DUTY CYCLE | CABLE SIZES FOR COMBINED LENGTHS OF ELECTRODE AND WORK CABLES | | | | |
| | | 0 to 50Ft. (0 to 15m) | 50 to 100Ft. (15 to 30m) | 100 to 150 Ft. (30 to 46m) | 150 to 200 Ft. (46 to 61m) | 200 to 250 Ft. (61 to 76m) |
| 200 | 60 | 2 | 2 | 2 | 1 | 1/0 |
| 200 | 100 | 2 | 2 | 2 | 1 | 1/0 |
| 225 | 20 | 4 or 5 | 3 | 4 or 5 | 1 | 1/0 |
| 225 | 40 & 30 | 3 | 3 | 3 | 1 | 1/0 |
| 250 | 30 | 3 | 3 | 3 | 1 | 1/0 |
| 250 | 40 | 2 | 2 | 2 | 1 | 1/0 |
| 250 | 60 | 1 | 1 | 1 | 1 | 1/0 |
| 250 | 100 | 1 | 1 | 1 | 1 | 1/0 |
| 300 | 60 | 1 | 1 | 1 | 1/0 | 1/0 |
| 350 | 100 | 2/0 | 2/0 | 2/0 | 2/0 | 2/0 |
| 350 | 60 | 1/0 | 1/0 | 1/0 | 2/0 | 3/0 |
| 400 | 60 | 2/0 | 2/0 | 2/0 | 3/0 | 4/0 |
| 400 | 100 | 3/0 | 3/0 | 3/0 | 3/0 | 4/0 |
| 500 | 60 | 2/0 | 2/0 | 2/0 | 3/0 | 4/0 |

** Tabled values are for operation at ambient temperatures of 104°F(40°C) and below. Applications above 104°F(40°C) may require cables larger than recommended, or cables rated higher than 167°F(75°C).

TRIGGER CONNECTOR

There is one circular connector for the gun trigger on the front of the DLF-72.

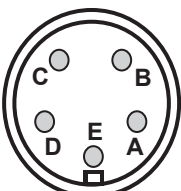
| Picture | Function | Pin | Wiring |
|---|-------------------------|------------|------------------------------|
|  | 5 PIN TRIGGER CONNECTOR | A | GUN TRIGGER SWITCH SUPPLY |
| | | B | NOT USED |
| | | C | GUN TRIGGER SWITCH |
| | | D | DUAL PROCEDURE SWITCH |
| | | E | DUAL PROCEDURE SWITCH SUPPLY |

⚠ WARNING

ELECTRIC SHOCK CAN KILL.

- Do not touch electrically live parts.



PROCEDURE TO INSTALL DRIVE ROLLS AND WIRE GUIDES

⚠ WARNING

ELECTRIC SHOCK CAN KILL.

- Turn the input power OFF at the welding power source before installation or changing drive rolls and/or guides.
- Do not touch electrically live parts.
- When inching with the gun trigger, electrode and drive mechanism are "hot" to work and ground and could remain energized several seconds after the gun trigger is released.
- Do not operate with covers, panels or guards removed or open.
- Only qualified personnel should perform maintenance work.



PRESSURE ARM ADJUSTMENT

⚠ WARNING

ELECTRIC SHOCK CAN KILL.

- Turn the input power OFF at the welding power source before installation or changing drive rolls and/or guides.
- Do not touch electrically live parts.
- When inching with the gun trigger, electrode and drive mechanism are "hot" to work and ground and could remain energized several seconds after the gun trigger is released.
- Do not operate with covers, panels or guards removed or open.
- Only qualified personnel should perform maintenance work.



1. Turn power off at the welding power source.
2. Release the idle roll pressure arm.
3. Remove the outer wire guide by turning the knurled thumbscrews counter-clockwise to unscrew them from the feedplate.
4. Rotate the locking hub lock and remove the drive rolls.

The pressure arm controls the amount of force the drive rolls exert on the wire. Proper adjustment of the pressure arm gives the best welding performance.

Set the pressure arm as follows:

FIGURE A.3

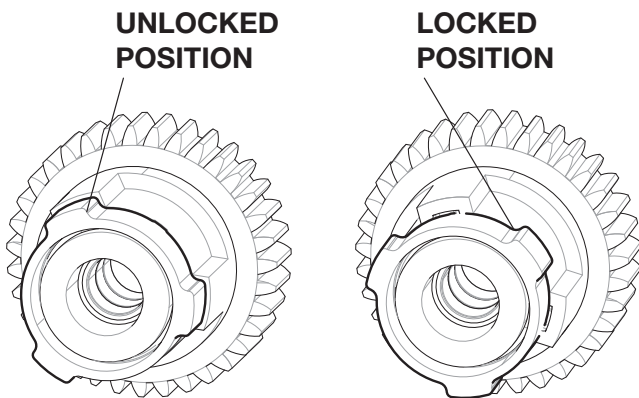

| | |
|------------------------|-----------------|
| Aluminum wires | between 1 and 3 |
| Cored wires | between 3 and 4 |
| Steel, Stainless wires | between 4 and 6 |

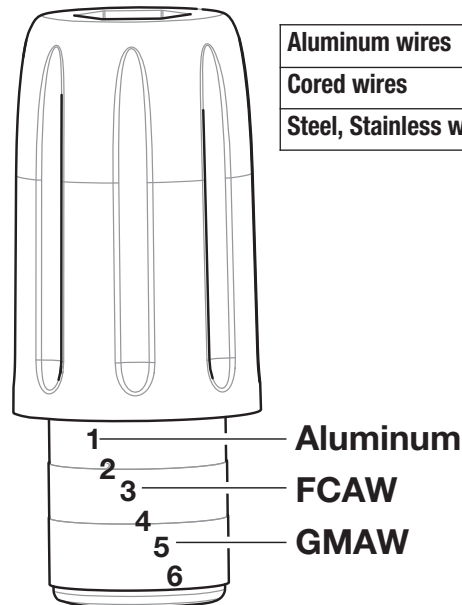

5. Remove the inner wire guide.
6. Insert the new inner wire guide, groove side out, over the two locating pins in the feedplate.
7. Install a drive roll on each hub assembly secure with the locking hub.
8. Install the outer wire guide by aligning it with the pins and tightening the knurled thumbscrews.
9. Close the idle arm and engage the idle roll pressure arm. Adjust the pressure appropriately.

CHANGING THE GUN ADAPTER BUSHING

WARNING

ELECTRIC SHOCK CAN KILL.

- Turn the input power OFF at the welding power source before installation or changing drive rolls and/or guides.
- Do not touch electrically live parts.
- When inching with the gun trigger, electrode and drive mechanism are "hot" to work and ground and could remain energized several seconds after the gun trigger is released.
- Do not operate with covers, panels or guards removed or open.
- Only qualified personnel should perform maintenance work.



Tools required:

- 1/8" hex key wrench
- Phillips Head Screwdriver
- 3/4" Wrench

Note: Some gun adapters do not require the use of the thumb screw.

1. Turn power off at the welding power source.
2. Remove the welding wire from the wire drive.
3. Remove the thumb screw from the wire drive.
4. Remove the welding gun from the wire drive.
5. Remove 3/4" bolt from gun adapter to remove weld cable.
6. Remove Sense Lead connection from gun adapter by loosening phillips head screw.
7. Loosen the Hex Head Set Screw that holds the gun adapter in place. Important: **Do not attempt to completely remove the Hex Head Set Screw.**
8. Remove the outer wire guide, and push the gun adapter out of the wire drive. Because of the precision fit, light tapping may be required to remove the gun bushing.
9. Disconnect the shielding gas hose from the gun bushing, if required.
10. Connect the shielding gas hose to the new gun adapter, if required.
11. Rotate the gun adapter until the thumb screw hole aligns with the thumb screw hole in the feedplate. Slide the gun receiver bushing into the wire drive and verify the thumb screw holes are aligned.
12. Tighten the Hex Head Set Screw.
13. Place 3/4" screw onto weld cable and tighten on-to gun adapter.
14. Insert the welding gun into the gun adapter and tighten the thumb screw.
15. Replace sense lead connection by placing phillips head screw into gun bushing adapter and tighten.

FIGURE A.2

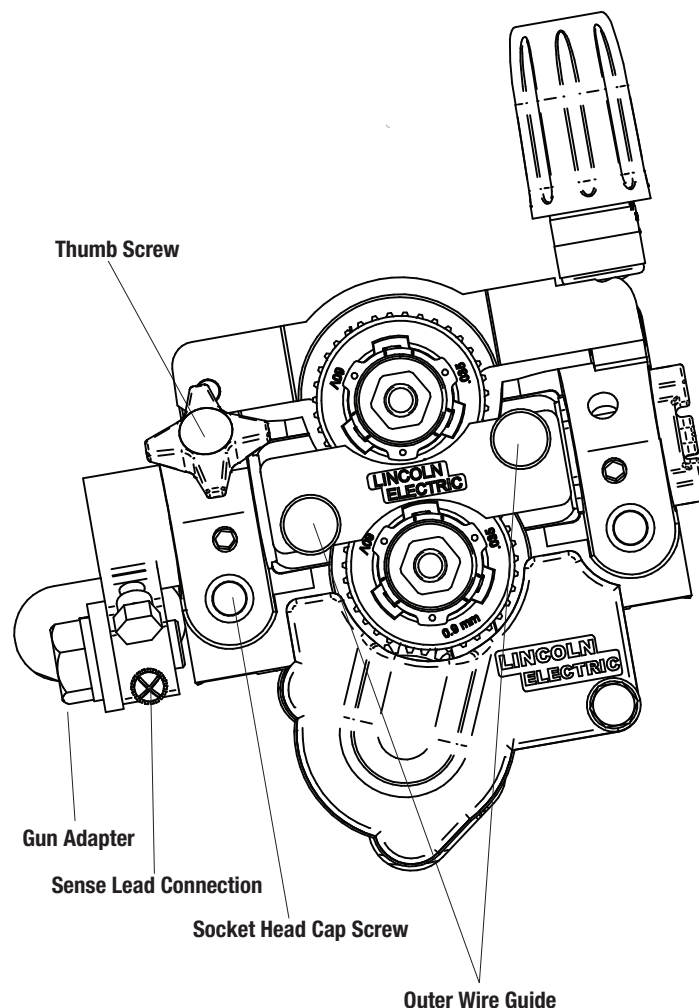

GUN CONNECTION

⚠ WARNING**ELECTRIC SHOCK CAN KILL.**

- Turn the input power OFF at the welding power source before installation or changing drive rolls and/or guides.
- Do not touch electrically live parts.
- When inching with the gun trigger, electrode and drive mechanism are "hot" to work and ground and could remain energized several seconds after the gun trigger is released.
- Do not operate with covers, panels or guards removed or open.
- Only qualified personnel should perform maintenance work.



The DLF-72 comes with an adapter installed, that accepts #2 - #4 guns. To install a gun:

1. Turn power OFF at the welding power source.
2. Remove the thumb screw.
3. Push the gun the completely into the gun bushing.
4. Secure the gun in place with the thumb screw.
5. Connect the trigger cable from the gun to the trigger connector on the front of the feeder.

Note: Not all gun bushings require the use of the thumb screw.

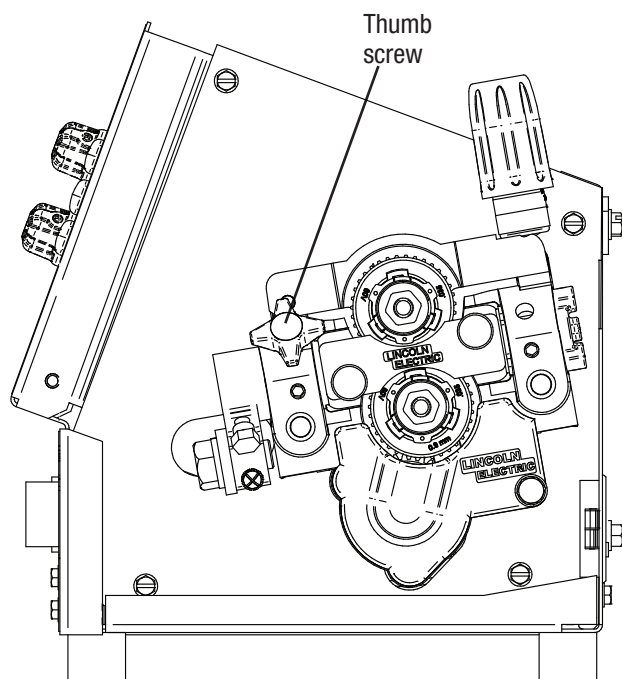

SHIELDING GAS CONNECTION

⚠ WARNING**CYLINDER may explode if damaged.**

- Keep cylinder upright and chained to support.
- Keep cylinder away from areas where it may be damaged.
- Never lift welder with cylinder attached.
- Never allow welding electrode to touch cylinder.
- Keep cylinder away from welding or other live electrical circuits.

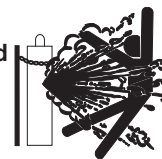
**Build up of shielding gas may harm health or kill.**

- Shut off shielding gas supply when not in use.
- See American National Standard Z-49.1, "Safety in Welding and Cutting" Published by the American Welding Society.

**Maximum inlet pressure is 100 psi. (6.9 bar.)**

Install the shielding gas supply as follows:

1. Secure the cylinder to prevent it from falling.
2. Remove the cylinder cap. Inspect the cylinder valves and regulator for damaged threads, dirt, dust, oil or grease. Remove dust and dirt with a clean cloth. **DO NOT ATTACH THE REGULATOR IF OIL, GREASE OR DAMAGE IS PRESENT!** Inform your gas supplier of this condition. Oil or grease in the presence of high pressure oxygen is explosive.
3. Stand to one side away from the outlet and open the cylinder valve for an instant. This blows away any dust or dirt which may have accumulated in the valve outlet.
4. Attach the flow regulator to the cylinder valve and tighten the union nut(s) securely with a wrench. Note: if connecting to 100% CO₂ cylinder, insert regulator adapter between regulator and cylinder valve. If adapter is equipped with a plastic washer, be sure it is seated for connection to the CO₂ cylinder.
5. Attach one end of the inlet hose to the outlet fitting of the flow regulator. Attach the other end to the welding system shielding gas inlet. Tighten the union nuts with a wrench.
6. Before opening the cylinder valve, turn the regulator adjusting knob counterclockwise until the adjusting spring pressure is released.
7. Standing to one side, open the cylinder valve slowly a fraction of a turn. When the cylinder pressure gage stops moving, open the valve fully.

OPERATION

SAFETY PRECAUTIONS

WARNING

ELECTRIC SHOCK can kill.

- Do not touch electrically live parts or electrode with skin or wet clothing.
- Insulate yourself from work and ground.
- Always wear dry insulating gloves.



FUMES AND GASES can be dangerous.

- Keep your head out of fumes.
- Use ventilation or exhaust to remove fumes from breathing zone.



ARC RAYS can burn.

- Wear eye, ear and body protection.



Observe additional Safety Guidelines detailed in the beginning of this manual.

The serviceability of a product or structure utilizing the DLF-72 wirefeeder is and must be the sole responsibility of the builder/user. Many variables beyond the control of The Lincoln Electric Company affect the results obtained in using the DLF-72 wirefeeder. These variables include, but are not limited to, welding procedure, plate chemistry and temperature, weldment design, fabrication methods and service requirements. The available range of the DLF-72 wirefeeder may not be suitable for all applications, and the builder/user is and must be solely responsible for welding settings.

POWER-UP SEQUENCE

If the gun trigger is activated during power up, the feeder will not operate until the gun trigger is released.

GRAPHIC SYMBOLS THAT APPEAR ON THIS MACHINE OR IN THIS MANUAL



WARNING OR CAUTION



INPUT VOLTAGE



OUTPUT ON



GAS PURGE



HIGH TEMPERATURE



READ INSTRUCTION
MANUAL



GAS INPUT



GAS OUTPUT

**TYPICAL SET-UP WITH ARCLINK®
(RECOMMENDED)**

Place the power source in ArLink® Mode.

| Item | K# | Description |
|------|---------------|-----------------------------------|
| 1 | K5280-1 | DLF-72 |
| | K3607-2 | Flextec 500X Multi-Process Welder |
| 2 | KP1696-1 | Drive Roll Kit |
| 3 | K4532-2-10-45 | Magnum Pro Curve HDE 350 |
| 4 | K2484-2 | Work Cable |

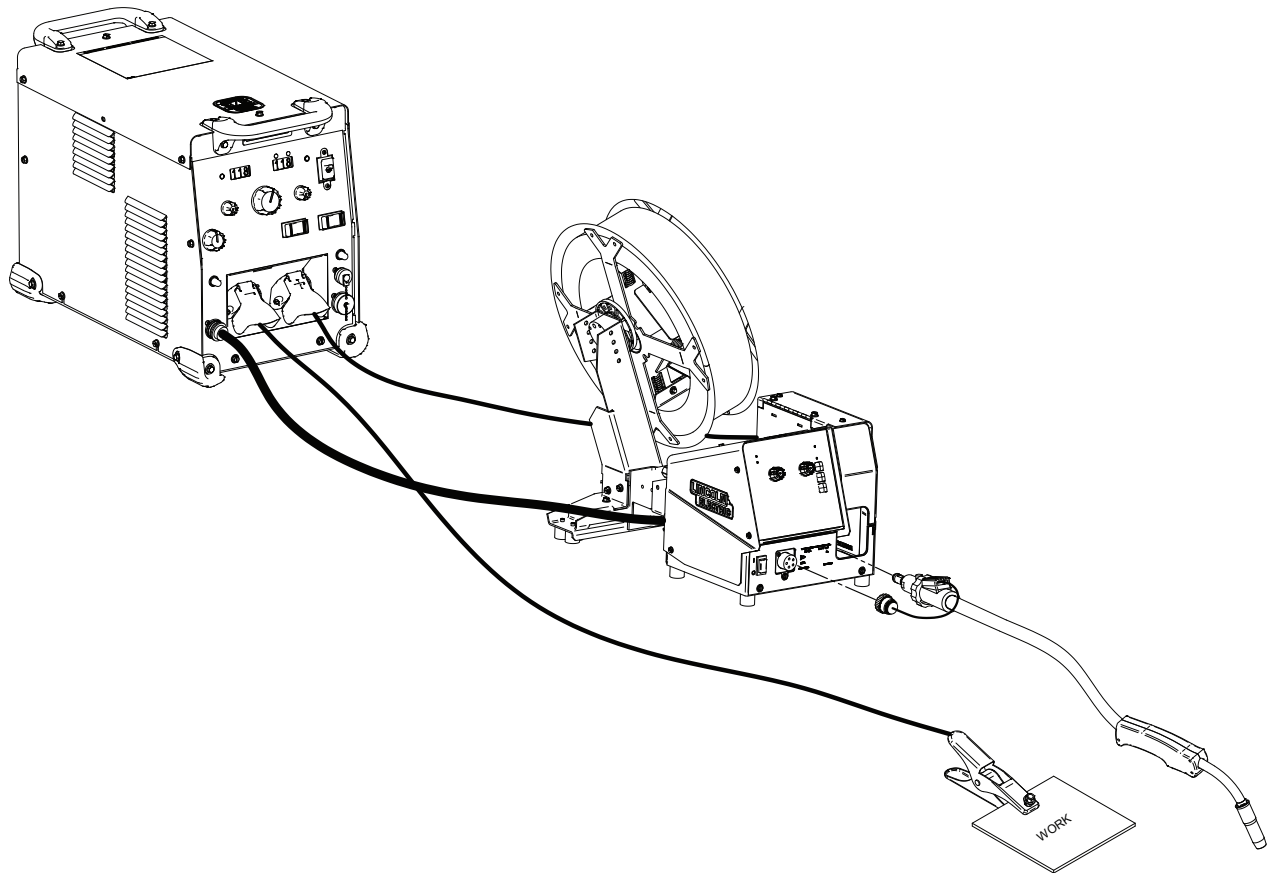

DEFINITION OF WELDING TERMS

NON-SYNERGIC WELDING MODES

- A Non-synergic welding mode requires all welding process variables to be set by the operator.

SYNERGIC WELDING MODES

- A Synergic welding mode offers the simplicity of single knob control. The machine will select the correct voltage and amperage based on the wire feed speed (WFS) set by the operator.

WFS

- Wire Feed Speed

CC

- Constant Current

CV

- Constant Voltage

GMAW

- Gas Metal Arc Welding

GMAW-STT

- Gas Metal Arc Welding-(Surface Tension Transfer)

SMAW

- Shielded Metal Arc Welding

GTAW

- Gas Tungsten Arc Welding

FCAW

- Flux Core Arc Welding

CAG

- Carbon Arc Gouging

DIGITAL METER OPERATION - WHILE IDLE

The left display shows the preset wire feed speed while the right display shows the preset voltage when it is connected to a power source that supports the DLF-72 (see Figure B.1). The DLF-72 will display "Err 262" if connected to an incompatible power source. If the power source's mode selection is not in ArcLink® Mode, display will show "Sleep".

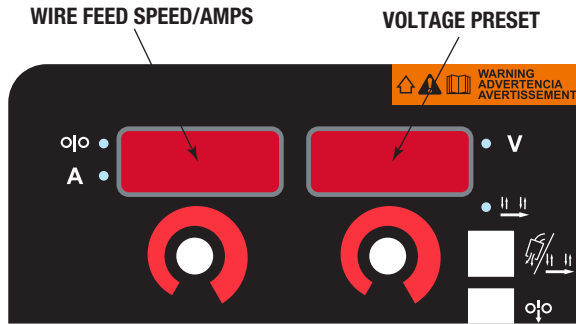

Figure B.1

DIGITAL METER OPERATION - WHILE WELDING

The left display shows amps or WFS based on the selection in the settings menu (the corresponding LED will be illuminated). The right display shows Voltage.

DIGITAL METER OPERATION - AFTER WELDING

The display continues to hold the value of the amperage or WFS and arc voltage for five seconds after the completion of each weld. The corresponding LEDs for amperage/WFS or Voltage will flash at a 1 second rate to identify these as "Look Back" values. Turning either of the 2 knobs will cause the displays to show preset information.

SETTINGS MENU:

There are 2 levels of menus that can be accessed on the DLF-72.

To enter the welding menu system, press the menu button on the bottom right.

Rotating the left encoder knob will change the menu item.

Rotating the right encoder knob will change the menu item's setting.

Pressing the Menu Button again will exit the menu.

Settings Menu items are:

- Arc Control
- Preflow
- Postflow
- Burn Back
- Units Metric / Imperial
- Display Arc Current/WFS

Arc Control (Arc):

In CV modes arc control is used to vary the pinch or inductance to control spatter, fluidity and bead appearance.

When ACTL is selected in the setting menu, it will appear on the left display. To change the value turn the right knob clockwise to increase and counter-clockwise to decrease the value.

It can be adjusted from the range -10.0 to +10.0.

Run-in Speed (% of weld WFS) (run):

Run-in speed is used to modify the wire feed speed during the beginning of the weld. After the preflow time period expires the wire will begin to be fed at the run in speed. By default it is set to Auto and can be shut off, or modified between 10 and 50%.

Preflow Time (PrE FLo):

This setting changes the amount of time that the solenoid is held closed before the welding torch is energized and the wire is fed. The welding gas will begin to flow immediately when the gun trigger is pulled.

The default preflow time is selected to be Auto. The available range can be adjusted to be off or adjusted between 0.1s and 10.0s.

Postflow Time (POSt FLo):

This setting changes the amount of time that the gas solenoid is held closed after the welding arc is commanded off. The welding gas will continue to flow for the set amount of time.

The default postflow time is selected to be Auto. Postflow can be turned off here as well. It can also be adjusted between 0.1s and 10.0s.

Burnback Time (burn bAC):

Burnback defines the amount of time the arc will continue after the trigger is released and the wire is no longer being fed. It can be used to reduce the wire stickout after a weld.

The default burnback time is Auto. It can be turned off in the menu or adjusted between 0.05s - 0.250s.

Units (Unit):

The wire feed speed settings can be viewed in Metric or Imperial Units by selecting either "US" or "Euro" in the Units section of the Setup Menu. By default "US" is selected.

Display Units (diSP):

The units shown on the left display while welding can be changed from the default of Arc Current in Amps. When "diSP" is selected in the menu, the right knob can be turned to select "Curr" or "Feed". Curr will show Arc Current in Amps. Feed will display wire feed speed in inches per minute or meters per minute depending on the setting of the Units Menu Item.

ADVANCED MENU:

The Advanced Menu can be accessed by pressing and holding the Menu Button for 5 seconds. This menu allows the user to view the Software Revision and restore the unit to factory default settings. The menu items can be scrolled through by pressing the Menu Button once in the Advanced Menu.

Restore Factory Default (dFLt):

The second menu item allows the user to restore the machine to its factory defaults. The option can be selected by turning the right knob when "dFLt" is selected.

Software Revision:

The first menu item displays the software revision followed by the Checksum. This information may be useful when communicating machine version to service.

Calibration Speed (CAL Spd):

This is used to calibrate the wfs meter to a known calibrated WFS Meter. To calibrate the wire feed speed, before entering the Setup Menu, use the following procedure:

- Set the display to desired WFS Setpoint using the left knob (ex: 400 IPM)
- Measure the actual WFS (ex: 405 IPM)
- Calibration Factor = Actual WFS / Set WFS
- For this example, $405/400 = 1.01$
- Navigate to the "CAL Spd" Menu Item
- Use the right encoder to increase or decrease the value to 1.01

CASE FRONT CONTROLS

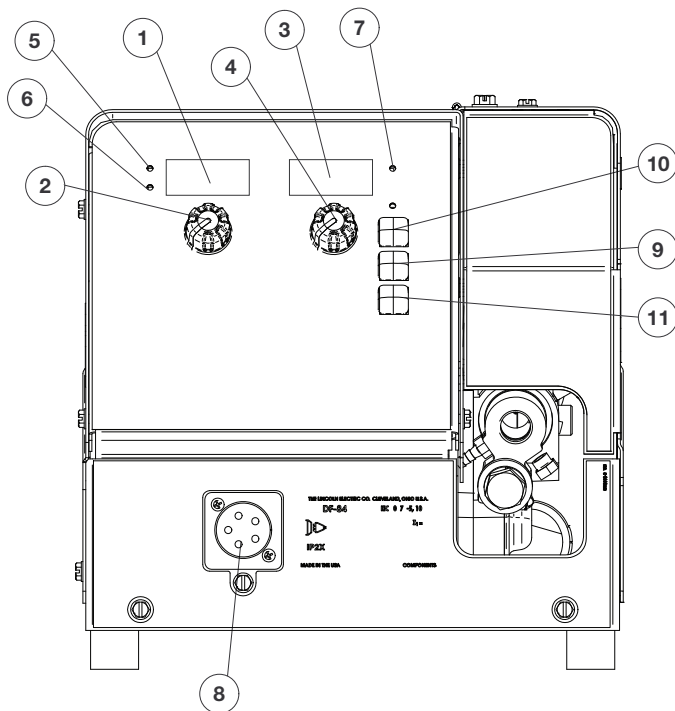

1. **Wire Feed Speed Digital Display** - The DLF-72 has a digital display that shows the wire feed speed. This display is also capable of displaying amperage and the setup menu.
2. **Wire Feed Speed Knob** - Use the Wire Feed Speed Knob to set the rate of wire feed speed. The wire feed speed will be displayed on the Wire Feed Speed Digital Display. During CV operation, the wire feed speed will remain a constant value, independent of arc voltage changes.
3. **Voltage/Trim Digital Display** - The DLF-72 has a digital display that shows the voltage/trim between electrode and work.
4. **Voltage/Trim Knob** - Use the Voltage Knob to set the voltage and it will be displayed on the Voltage Digital Display. During CV operation, the voltage will remain stable while welding.
5. **Wire Feed Speed LED** - The Wire Feed Speed and Amperage LEDs will communicate what is being displayed on the Wire Feed Speed Digital Display. When the Wire Feed Speed LED is illuminated, wire feed speed is being displayed.
6. **Amperage LED** - When the Amperage LED is illuminated, amperage is being displayed.
7. **Voltage LED** - The Voltage LED will be illuminated when the Voltage Digital Display is displaying actual voltage.
8. **Five Pin Gun Trigger Connector** - The 5 Pin Gun Trigger Connector is where the trigger that is attached to the welding gun is connected. This will actuate the welding current when the trigger is pulled.
9. **Cold Inch Button** - Push to activate wire drive motor without energizing the feedplate and release to halt feeding.
10. **Gas Purge /4-Step (4Stp) Operation** -
 Gas Purge operation: press the button, As long as the button is pushed the gas solenoid will close, allowing gas to flow.
 4 Step operation: press and release the button. The display will show "4stp" "off" or "on". The right knob can then be turned clockwise or counter clockwise to turn 4 step mode on or off. The case front LED next to the 4 step symbol will be on when 4 step is on and off when it is off.
11. **Menu Button** - Push this button to enter the setup menu. Once in the menu it can be pushed again to exit the menu. Push and hold for 5 seconds to enter the Advanced Menu. Pushing again will exit the menu.

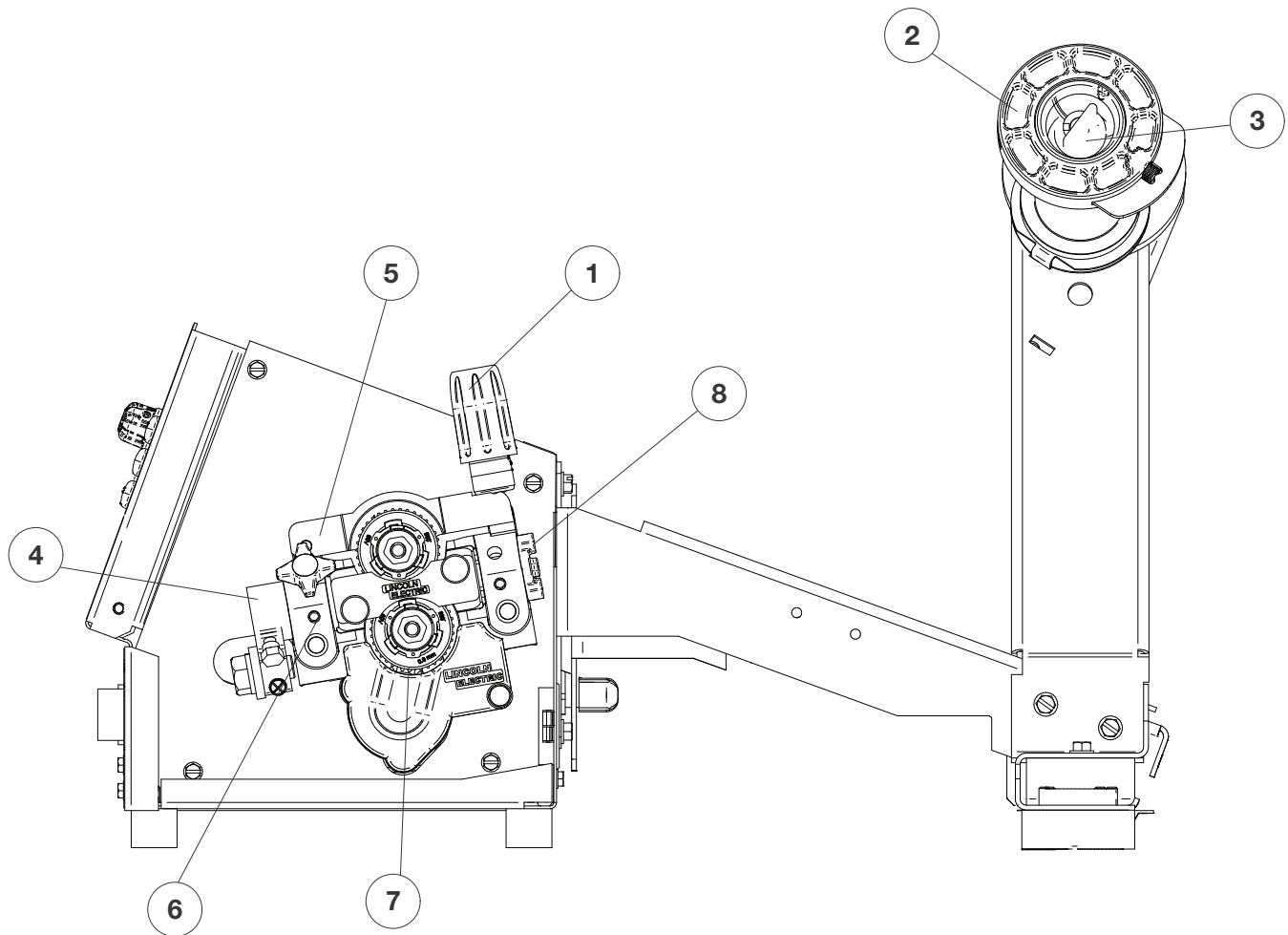
INTERNAL CONNECTIONS

1. Pressure Arm Adjustment Knob
2. Spool Retainer
3. Spindle Brake
4. Gun Bushing
5. Thumb Screw
6. Socket Head Cap Screw For Gun Bushing
7. Drive Hubs
8. Inlet Wire Guide

REAR CONNECTIONS**⚠ CAUTION**

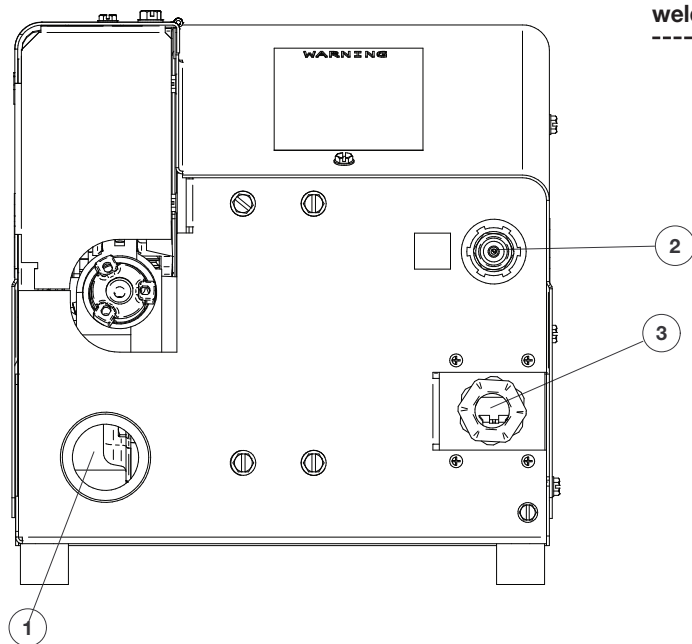

The serviceability of a product or structure utilizing the DLF-72 wire feeder is and must be the sole responsibility of the builder/user. Many variables beyond the control of The Lincoln Electric Company affect the results obtained in using the DLF-72 wire feeder. These variables include, but are not limited to, welding procedure, plate chemistry and temperature, weldment design, fabrication methods and service requirements. The available range of the DLF-72 wirefeeder may not be suitable for all applications, and the builder/user is and must be solely responsible for welding settings.



1. Electrode Lead Connection from power source
2. Shielding Gas Inlet
3. Arclink Cable Connection

OPTIONS/ACCESSORIES

The following options/accessories are available for your DLF-72 from your local Lincoln Electric Distributor.

| DRIVE ROLL KITS, 2 ROLL DRIVE | | | |
|--------------------------------------|------------------------|---|---|
| Steel Wire Drive Roll Kits | | | |
| KP1696-030S | .023-.030 (0.6-0.8MM) | INCLUDES: 2 V GROOVE DRIVE ROLLS AND INNER WIRE GUIDE. |  |
| KP1696-035S | .035 (0.9MM) | | |
| KP1696-045S | .045 (1.2MM) | | |
| KP1696-052S | .052 (1.4MM) | | |
| KP1696-1/16S | 1/16 (1.6MM) | | |
| KP1696-1* | .035,.045 (0.9, 1.2MM) | | |
| KP1696-2 | .040 (1.0MM) | | |
| Cored Wire Drive Roll Kits | | | |
| KP1697-035C | .030-.035" (0.8-0.9MM) | INCLUDES: 2 KNURLED DRIVE ROLLS AND INNER WIRE GUIDE. |  |
| KP1697-045C | .040-.045" (1.0-1.2MM) | | |
| KP1697-052C | .052" (1.4MM) | | |
| KP1697-1/16C | 1/16" (1.6MM) | | |
| KP1697-068 | .068-.072" (1.7-1.8MM) | | |
| KP1697-5/64 | 5/64" (2.0MM) | | |

*Included with DLF-72

Optional Kits & Accessories

K2485-2 Weld Cable Tweco Male to Tweco Female (2/0), 50ft.

K2485-3 Weld Cable Tweco Male to Tweco Female (3/0), 50ft.

K2487-1 Lug to Tweco Female adapter.

K3349-1

Feed Plate Adapter

Compatible with single and dual procedure guns. Also requires K3344-1 Lincoln Adapter.

Includes: Gun receiver bushing with trigger connector.



K586-1

Deluxe Adjustable Gas Regulator

Includes: Deluxe Gas Regulator for Mixed Gases, Adapter for CO2 and 10' (3.0m) Hose.



K283

Wire Feed Speed Meter

Includes: A wire feed speed meter with digital display.



K910-1 & K910-2

Work Clamp

Jaws open full 2-1/2 inches (63 mm). Welding cable lug bolts directly to the work clamp. 60% duty cycle. Select K910-1 for 300 Amp applications. K910-2 for 500 Amp.



MAINTENANCE

WARNING

ELECTRIC SHOCK CAN KILL.

- Turn the input power OFF at the welding power source before installation or changing drive rolls and/or guides.
- Do not touch electrically live parts.
- When inching with the gun trigger, electrode and drive mechanism are "hot" to work and ground and could remain energized several seconds after the gun trigger is released.
- Do not operate with covers, panels or guards removed or open.
- Only qualified personnel should perform maintenance work.



ROUTINE MAINTENANCE

- Check weld cables and gas hoses for cuts.
- Clean and tighten all weld terminals.

PERIODIC MAINTENANCE

- Clean the drive rolls and inner wire guide and replace if worn.
- Blow out or vacuum the inside of the feeder.

TROUBLESHOOTING



WARNING

Service and Repair should only be performed by Lincoln Electric Factory Trained Personnel. Unauthorized repairs performed on this equipment may result in danger to the technician and machine operator and will invalidate your factory warranty. For your safety and to avoid Electrical Shock, please observe all safety notes and precautions detailed throughout this manual.

This Troubleshooting Guide is provided to help you locate and repair possible machine malfunctions. Simply follow the three-step procedure listed below.

Step 1. LOCATE PROBLEM (SYMPTOM).

Look under the column labeled “PROBLEM (SYMPTOMS).” This column describes possible symptoms that the machine may exhibit. Find the listing that best describes the symptom that the machine is exhibiting.

Step 2. POSSIBLE CAUSE.

The second column labeled “POSSIBLE CAUSE” lists the obvious external possibilities that may contribute to the machine symptom.

Step 3. RECOMMENDED COURSE OF ACTION

This column provides a course of action for the Possible Cause, generally it states to contact your local Lincoln Authorized Field Service Facility.

If you do not understand or are unable to perform the Recommended Course of Action safely, contact your local Lincoln Authorized Field Service Facility.



If for any reason you do not understand the test procedures or are unable to perform the tests/repairs safely, contact your Lincoln Authorized Service Facility for technical troubleshooting assistance before you proceed.

WWW.LINCOLNELECTRIC.COM/LOCATOR

Observe all Safety Guidelines detailed throughout this manual

| PROBLEM | POSSIBLE CAUSE | RECOMMENDED COURSE OF ACTION |
|--|--|--|
| Err 82 Motor overload, long term | The wire drive motor has overheated. | <ol style="list-style-type: none"> 1. Check that the electrode slides easily through the gun and cable. 2. Remove tight bends from the gun and cable. 3. Check that the spindle brake is not too tight. 4. Verify a high quality electrode is being used. 5. Wait for the error to reset and the motor to cool (approximately 1 minute). 6. Clean/inspect/replace liner. |
| Output Problems | | |
| The feeder does power up - no voltage, no cold feed. | <ol style="list-style-type: none"> 1. No output from power source. 2. Input ArkLink® cable is disconnected or broken. | <ol style="list-style-type: none"> 1. Won't power up if power source is off. |
| No shielding gas. | <ol style="list-style-type: none"> 1. The gas supply is OFF or empty. 2. The gas hose is cut or crushed 3. Dirt or debris is in the solenoid. 4. There is a loose solenoid connection. 5. The solenoid has failed. | <ol style="list-style-type: none"> 1. Verify the gas supply is ON and flowing. 2. Route the gas hose so it avoids sharp corners and make sure nothing is on top of it. Repair or replace damaged hoses. 3. Apply filtered shop air at 80psi to the solenoid to remove dirt. 4. Remove the cover and check that all connections are in good condition. |
| Inconsistent wire feeding or wire not feeding but drive rolls turning. | <ol style="list-style-type: none"> 1. The gun cable is kinked and/or twisted 2. The wire is jammed in the gun and cable. 3. The gun liner is dirty or worn. 4. The electrode is rusty or dirty. 5. The contact tip is partially melted or has spatter. 6. Improper gun liner, tip, drive | <ol style="list-style-type: none"> 1. Keep the gun cable as straight as possible. Avoid sharp corners or bends in the cable. 2. Remove the gun from the wire feeder and pull the jammed wire out of the gun and cable. 3. Blow dirt out of the liner with low pressure (40psi or less). Replace the liner if worn. 4. Replace contact tip. |



If for any reason you do not understand the test procedures or are unable to perform the tests/repairs safely, contact your Lincoln Authorized Service Facility for technical troubleshooting assistance before you proceed.

WWW.LINCOLNELECTRIC.COM/LOCATOR

Observe all Safety Guidelines detailed throughout this manual

| PROBLEM | POSSIBLE CAUSE | RECOMMENDED COURSE OF ACTION |
|--|---|--|
| Inconsistent wire feeding or wire not feeding but drive rolls turning. | <ol style="list-style-type: none"> 6. Improper gun liner, tip, drive rolls and/or inner wire guide. 7. Incorrect tension arm pressure on the drive rolls. 8. The spindle brake is too tight. 9. Worn drive roll. | <ol style="list-style-type: none"> 5. Verify the proper parts are installed. 6. Adjust the tension arm per the Instruction Manual. Most electrodes feed well at a tension arm setting of "3". 7. Verify the spool of wire moves with minimal effort. 8. Replace the drive rolls if worn or filled with dirt. |
| Wire feed speed consistently operates at the wrong value. The speed changes when the wire feed speed knob is adjusted. | <ol style="list-style-type: none"> 1. The wrong gear is installed in the wire drive. 2. The brushes on the motor are worn. | <ol style="list-style-type: none"> 1. Install the proper pinion gear in the wire drive. 2. Replace the motor/gearbox assembly. |
| The motor runs at max WFS and there is no change when the wire feed speed knob is adjusted. | <ol style="list-style-type: none"> 1. The tachometer is connected improperly. 2. The tachometer has failed. | <ol style="list-style-type: none"> 1. Verify all of the tachometer leads are properly connected. 2. Replace the motor and tachometer assembly. |
| Variable or "hunting" arc. | <ol style="list-style-type: none"> 1. Wrong size, worn and/or melted contact tip 2. Worn work cable or poor work connection. 3. Wrong polarity. 4. The gas nozzle is extended beyond the contact tip or the wire stickout is too long. 5. Poor gas shielding on processes requiring gas. | <ol style="list-style-type: none"> 1. Replace the contact tip. 2. Verify all work and electrode connections are tight and that the cables are in good condition. Clean/replace as necessary. 3. Adjust the gas nozzle and shorten the stickout to ½ to ¾ inches. 4. Check gas flow and mixture. Remove or block sources of drafts. |
| When the trigger is pulled, the wire feeds slowly. | The Run-In set to "ON" | Use the set-up Push-button to turn Run-in OFF. |
| Poor arc starts with sticking or "blast-offs", weld porosity, narrow and ropy looking bead. | Improper procedures or techniques. | See "Gas Metal Arc Welding Guide" (GS-100) |



If for any reason you do not understand the test procedures or are unable to perform the tests/repairs safely, contact your Lincoln Authorized Service Facility for technical troubleshooting assistance before you proceed.

WWW.LINCOLNELECTRIC.COM/LOCATOR

DLF-72/82 FEEDER

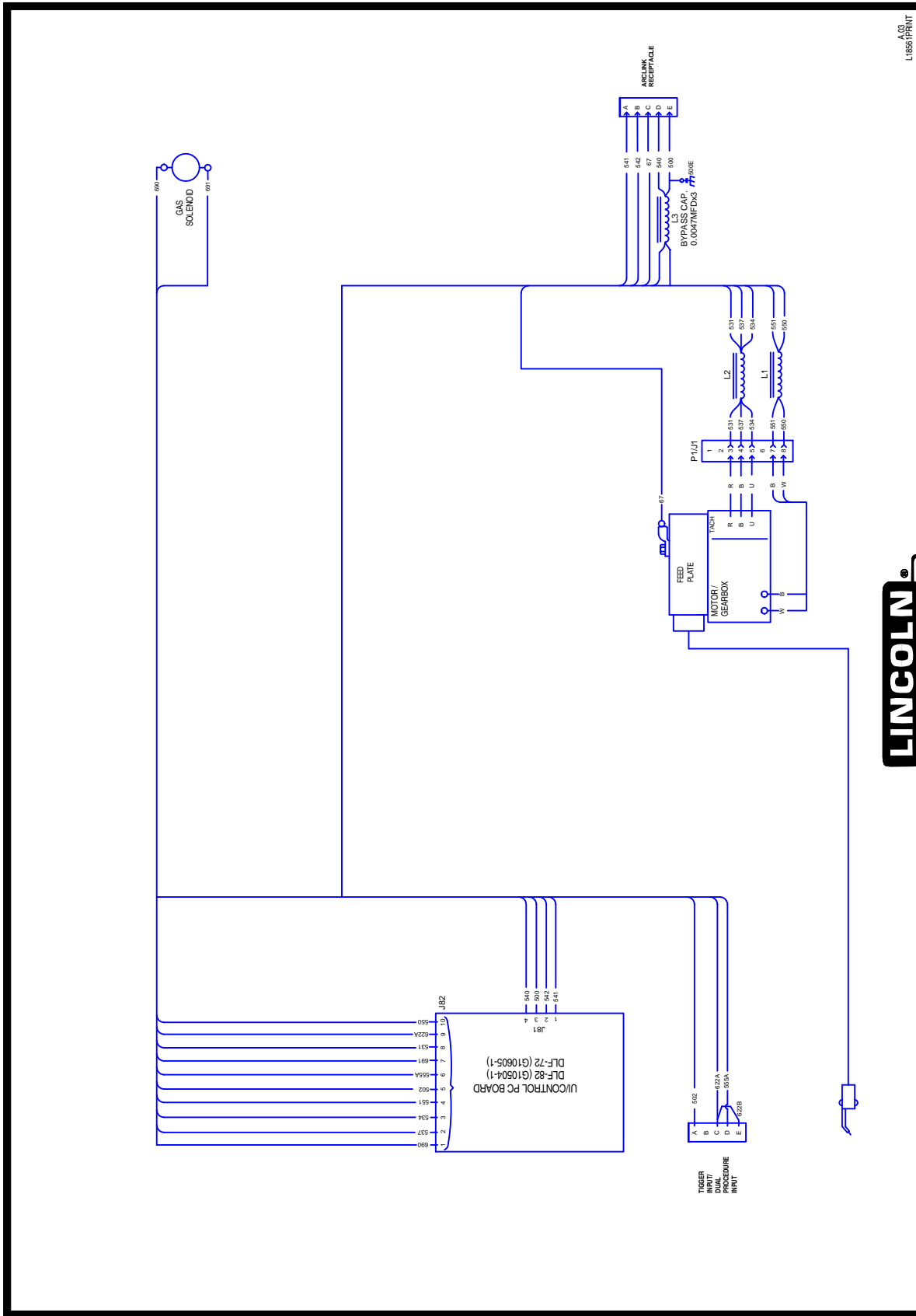

CLEVELAND, OHIO U.S.A.

A 08
L18651PRINT

NOTE: This diagram is for reference only. It may not be accurate for all machines covered by this manual. The specific diagram for a particular code is pasted inside the machine on one of the enclosure panels. If the diagram is illegible, write to the Service Department for a replacement. Give the equipment code number.

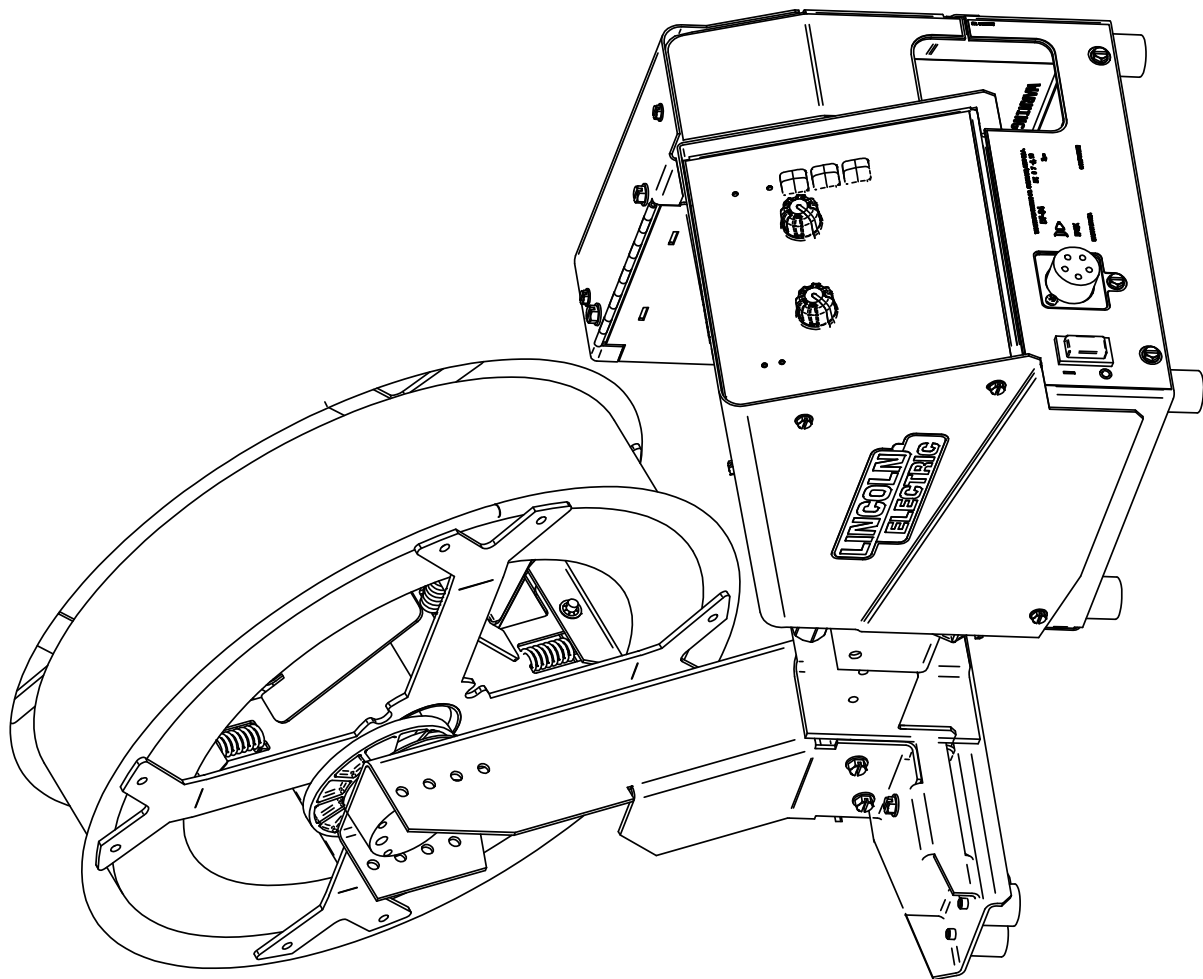
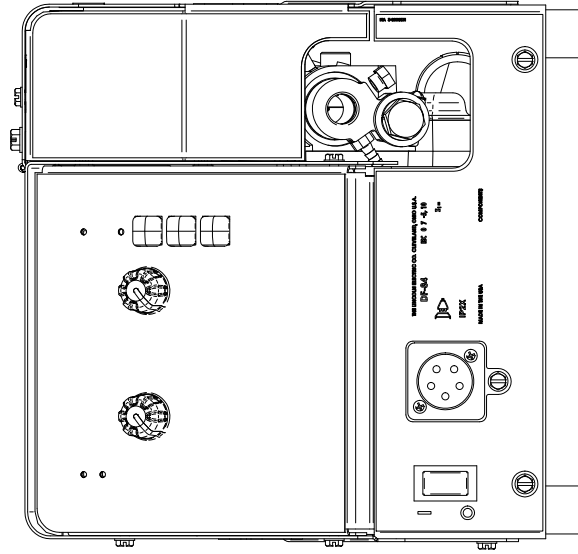

| | | | |
|--|---|---|---|
|  |  |  |  |
| WARNING | <ul style="list-style-type: none"> ● Do not touch electrically live parts or electrode with skin or wet clothing. ● Insulate yourself from work and ground. | <ul style="list-style-type: none"> ● Keep flammable materials away. | <ul style="list-style-type: none"> ● Wear eye, ear and body protection. |
| Spanish AVISO DE PRECAUCION | <ul style="list-style-type: none"> ● No toque las partes o los electrodos bajo carga con la piel o ropa mojada. ● Aíslese del trabajo y de la tierra. | <ul style="list-style-type: none"> ● Mantenga el material combustible fuera del área de trabajo. | <ul style="list-style-type: none"> ● Protéjase los ojos, los oídos y el cuerpo. |
| French ATTENTION | <ul style="list-style-type: none"> ● Ne laissez ni la peau ni des vêtements mouillés entrer en contact avec des pièces sous tension. ● Isolez-vous du travail et de la terre. | <ul style="list-style-type: none"> ● Gardez à l'écart de tout matériel inflammable. | <ul style="list-style-type: none"> ● Protégez vos yeux, vos oreilles et votre corps. |
| German WARNUNG | <ul style="list-style-type: none"> ● Berühren Sie keine stromführenden Teile oder Elektroden mit Ihrem Körper oder feuchter Kleidung! ● Isolieren Sie sich von den Elektroden und dem Erdboden! | <ul style="list-style-type: none"> ● Entfernen Sie brennbares Material! | <ul style="list-style-type: none"> ● Tragen Sie Augen-, Ohren- und Körperschutz! |
| Portuguese ATENÇÃO | <ul style="list-style-type: none"> ● Não toque partes elétricas e electrodos com a pele ou roupa molhada. ● Isole-se da peça e terra. | <ul style="list-style-type: none"> ● Mantenha inflamáveis bem guardados. | <ul style="list-style-type: none"> ● Use proteção para a vista, ouvido e corpo. |
| Japanese 注意事項 | <ul style="list-style-type: none"> ● 通電中の電気部品、又は溶材にヒフやぬれた布で触れないこと。 ● 施工物やアースから身体が絶縁されている様にして下さい。 | <ul style="list-style-type: none"> ● 燃えやすいものの側での溶接作業は絶対にしてはなりません。 | <ul style="list-style-type: none"> ● 目、耳及び身体に保護具をして下さい。 |
| Chinese 警告 | <ul style="list-style-type: none"> ● 皮肤或湿衣物切勿接触带电部件及焊条。 ● 使你自已与地面和工件绝缘。 | <ul style="list-style-type: none"> ● 把一切易燃物品移离工作场所。 | <ul style="list-style-type: none"> ● 佩戴眼、耳及身体劳动保护用具。 |
| Korean 위험 | <ul style="list-style-type: none"> ● 전도체나 용접봉을 젖은 형갑 또는 피부로 절대 접촉치 마십시오. ● 모재와 접지를 접촉치 마십시오. | <ul style="list-style-type: none"> ● 인화성 물질을 접근시키지 마십시오. | <ul style="list-style-type: none"> ● 눈, 귀와 몸에 보호장구를 착용하십시오. |
| Arabic تحذير | <ul style="list-style-type: none"> ● لا تلمس الاجزاء التي يسري فيها التيار الكهربائي أو الألكترود بجسدك أو بالملابس المبللة بالماء. ● ضع عازلا على جسمك خلال العمل. | <ul style="list-style-type: none"> ● ضع المواد القابلة للاشتعال في مكان بعيد. | <ul style="list-style-type: none"> ● ضع أدوات وملابس واقية على عينيك وأذنيك وجسمك. |

READ AND UNDERSTAND THE MANUFACTURER'S INSTRUCTION FOR THIS EQUIPMENT AND THE CONSUMABLES TO BE USED AND FOLLOW YOUR EMPLOYER'S SAFETY PRACTICES.

SE RECOMIENDA LEER Y ENTENDER LAS INSTRUCCIONES DEL FABRICANTE PARA EL USO DE ESTE EQUIPO Y LOS CONSUMIBLES QUE VA A UTILIZAR, SIGA LAS MEDIDAS DE SEGURIDAD DE SU SUPERVISOR.

LISEZ ET COMPRENEZ LES INSTRUCTIONS DU FABRICANT EN CE QUI REGARDE CET EQUIPMENT ET LES PRODUITS A ETRE EMPLOYES ET SUIVEZ LES PROCEDURES DE SECURITE DE VOTRE EMPLOYEUR.

LESEN SIE UND BEFOLGEN SIE DIE BETRIEBSANLEITUNG DER ANLAGE UND DEN ELEKTRODENEINSATZ DES HERSTELLERS. DIE UNFALLVERHÜTUNGSVORSCHRIFTEN DES ARBEITGEBERS SIND EBENFALLS ZU BEACHTEN.

| | | | |
|---|--|---|--|
|  |  |  |  |
| <ul style="list-style-type: none"> ● Keep your head out of fumes. ● Use ventilation or exhaust to remove fumes from breathing zone. | <ul style="list-style-type: none"> ● Turn power off before servicing. | <ul style="list-style-type: none"> ● Do not operate with panel open or guards off. | WARNING |
| <ul style="list-style-type: none"> ● Los humos fuera de la zona de respiración. ● Mantenga la cabeza fuera de los humos. Utilice ventilación o aspiración para gases. | <ul style="list-style-type: none"> ● Desconectar el cable de alimentación de poder de la máquina antes de iniciar cualquier servicio. | <ul style="list-style-type: none"> ● No operar con panel abierto o guardas quitadas. | Spanish AVISO DE PRECAUCION |
| <ul style="list-style-type: none"> ● Gardez la tête à l'écart des fumées. ● Utilisez un ventilateur ou un aspirateur pour ôter les fumées des zones de travail. | <ul style="list-style-type: none"> ● Débranchez le courant avant l'entretien. | <ul style="list-style-type: none"> ● N'opérez pas avec les panneaux ouverts ou avec les dispositifs de protection enlevés. | French ATTENTION |
| <ul style="list-style-type: none"> ● Vermeiden Sie das Einatmen von Schweißrauch! ● Sorgen Sie für gute Be- und Entlüftung des Arbeitsplatzes! | <ul style="list-style-type: none"> ● Strom vor Wartungsarbeiten abschalten! (Netzstrom völlig öffnen; Maschine anhalten!) | <ul style="list-style-type: none"> ● Anlage nie ohne Schutzgehäuse oder Innenschutzverkleidung in Betrieb setzen! | German WARNUNG |
| <ul style="list-style-type: none"> ● Mantenha seu rosto da fumaça. ● Use ventilação e exaustão para remover fumo da zona respiratória. | <ul style="list-style-type: none"> ● Não opere com as tampas removidas. ● Desligue a corrente antes de fazer serviço. ● Não toque as partes elétricas nuas. | <ul style="list-style-type: none"> ● Mantenha-se afastado das partes moventes. ● Não opere com os painéis abertos ou guardas removidas. | Portuguese ATENÇÃO |
| <ul style="list-style-type: none"> ● ヒュームから頭を離すようにして下さい。 ● 換気や排煙に十分留意して下さい。 | <ul style="list-style-type: none"> ● メンテナンス・サービスに取りかかる際には、まず電源スイッチを必ず切して下さい。 | <ul style="list-style-type: none"> ● パネルやカバーを取り外したままで機械操作をしないで下さい。 | Japanese 注意事項 |
| <ul style="list-style-type: none"> ● 頭部遠離煙霧。 ● 在呼吸區使用通風或排風器除煙。 | <ul style="list-style-type: none"> ● 維修前切斷電源。 | <ul style="list-style-type: none"> ● 儀表板打開或沒有安全罩時不準作業。 | Chinese 警告 |
| <ul style="list-style-type: none"> ● 얼굴로부터 용접가스를 멀리하십시오. ● 호흡지역으로부터 용접가스를 제거하기 위해 가스제거기나 통풍기를 사용하십시오. | <ul style="list-style-type: none"> ● 보수전에 전원을 차단하십시오. | <ul style="list-style-type: none"> ● 판넬이 열린 상태로 작동치 마십시오. | Korean 위험 |
| <ul style="list-style-type: none"> ● ابعد رأسك بعيداً عن الدخان. ● استعمل التهوية أو جهاز ضغط الدخان للخارج لكي تبعد الدخان عن المنطقة التي تتنفس فيها. | <ul style="list-style-type: none"> ● اقطع التيار الكهربائي قبل القيام بأية صيانة. | <ul style="list-style-type: none"> ● لا تشغيل هذا الجهاز اذا كانت الاغطية الحديدية الواقية ليست عليه. | Arabic تحذير |

LEIA E COMPREENDA AS INSTRUÇÕES DO FABRICANTE PARA ESTE EQUIPAMENTO E AS PARTES DE USO, E SIGA AS PRÁTICAS DE SEGURANÇA DO EMPREGADOR.

使う機械や溶材のメーカーの指示書をよく読み、まず理解して下さい。そして貴社の安全規定に従って下さい。

請詳細閱讀並理解製造廠提供的說明以及應該使用的銀焊材料，並請遵守貴方的有關勞動保護規定。

이 제품에 동봉된 작업지침서를 숙지하시고 귀사의 작업자 안전수칙을 준수하시기 바랍니다.

اقرأ بتمعن وافهم تعليمات المصنع المنتج لهذه المعدات والمواد قبل استعمالها واتبع تعليمات الوقاية لصاحب العمل.

CUSTOMER ASSISTANCE POLICY

The business of The Lincoln Electric Company is manufacturing and selling high quality welding equipment, consumables, and cutting equipment. Our challenge is to meet the needs of our customers and to exceed their expectations. On occasion, purchasers may ask Lincoln Electric for advice or information about their use of our products. We respond to our customers based on the best information in our possession at that time. Lincoln Electric is not in a position to warrant or guarantee such advice, and assumes no liability, with respect to such information or advice. We expressly disclaim any warranty of any kind, including any warranty of fitness for any customer's particular purpose, with respect to such information or advice. As a matter of practical consideration, we also cannot assume any responsibility for updating or correcting any such information or advice once it has been given, nor does the provision of information or advice create, expand or alter any warranty with respect to the sale of our products.

Lincoln Electric is a responsive manufacturer, but the selection and use of specific products sold by Lincoln Electric is solely within the control of, and remains the sole responsibility of the customer. Many variables beyond the control of Lincoln Electric affect the results obtained in applying these types of fabrication methods and service requirements.

Subject to Change – This information is accurate to the best of our knowledge at the time of printing. Please refer to www.lincolnelectric.com for any updated information.



THE LINCOLN ELECTRIC COMPANY

22801 St. Clair Avenue • Cleveland, OH • 44117-1199 • U.S.A.
Phone: +1.216.481.8100 • www.lincolnelectric.com