

# Magnum™ PCT125/PCT125M

## Safety Depends on You

Lincoln arc welding and cutting equipment is designed and built with safety in mind. However, your overall safety can be increased by proper installation ... and thoughtful operation on your part. DO NOT INSTALL, OPERATE OR REPAIR THIS EQUIPMENT WITHOUT READING THIS MANUAL AND THE SAFETY PRECAUTIONS CONTAINED THROUGHOUT. And, most importantly, think before you act and be careful.

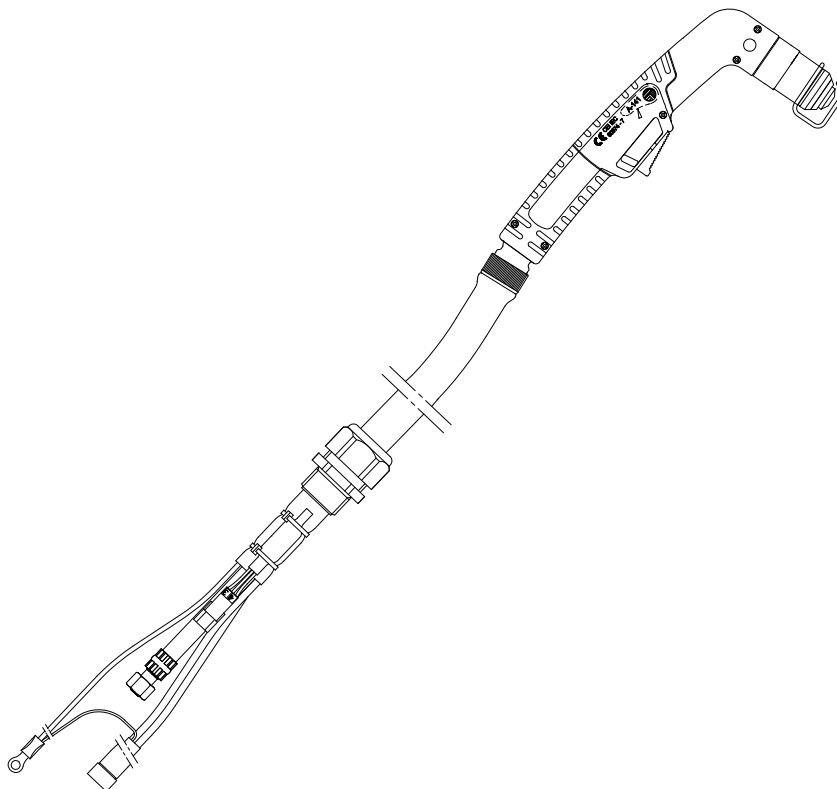

## OPERATOR'S MANUAL

**LINCOLN**®  
**ELECTRIC**

Copyright © 2004 Lincoln Global Inc.

• World's Leader in Welding and Cutting Products •

• Sales and Service through Subsidiaries and Distributors Worldwide •

Cleveland, Ohio 44117-1199 U.S.A. TEL: 216.481.8100 FAX: 216.486.1751 WEB SITE: [www.lincolnelectric.com](http://www.lincolnelectric.com)

**WARNING****PLASMA CUTTING or GOUGING can be hazardous.****PROTECT YOURSELF AND OTHERS FROM POSSIBLE SERIOUS INJURY OR DEATH. KEEP CHILDREN AWAY. PACEMAKER WEARERS SHOULD CONSULT WITH THEIR DOCTOR BEFORE OPERATING.**

Read and understand the following safety highlights. For additional safety information it is strongly recommended that you purchase a copy of "Safety in Welding & Cutting - ANSI Standard Z49.1" from the American Welding Society, P.O. Box 351040, Miami, Florida 33135 or CSA Standard W117.2.

**BE SURE THAT ALL INSTALLATION, OPERATION, MAINTENANCE, AND REPAIR PROCEDURES ARE PERFORMED ONLY BY QUALIFIED INDIVIDUALS.****ELECTRIC SHOCK can kill.**

1.a. The electrode and work (or ground) circuits are electrically "hot" when the power source is on. Do not touch these "hot" parts with your bare skin or wet clothing. Wear dry, hole-free gloves to insulate hands.

1.b. When the power source is operating voltages in excess of 250 volts are produced. This creates the potential for serious electrical shock - potentially even fatal.

1.c. Insulate yourself from work and ground using dry insulation. When cutting or gouging in damp locations, on metal framework such as floors, gratings or scaffolds and when in positions such as sitting or lying, make certain the insulation is large enough to cover your full area of physical contact with work and ground.

1.d. Always be sure the work cable makes a good electrical connection with the metal being cut or gouged. The connection should be as close as possible to the area being cut or gouged.

1.e. Ground the work or metal to be cut or gouged to a good electrical (earth) ground.

1.f. Maintain the plasma torch, cable and work clamp in good, safe operating condition. Replace damaged insulation.

1.g. Never dip the torch in water for cooling or plasma cut or gouge in or under water.

1.h. When working above floor level, protect yourself from a fall should you get a shock.

1.i. Operate the pilot arc with caution. The pilot arc is capable of burning the operator, others or even piercing safety clothing.

1.j. Also see Items 4c and 6.

**FUMES AND GASES can be dangerous.**

3.a. Plasma cutting or gouging may produce fumes and gases hazardous to health. Avoid breathing these fumes and gases. When cutting or gouging, keep your head out of the fumes. Use enough ventilation and/or exhaust at the arc to keep fumes and gases away from the breathing zone. **When cutting or gouging on lead or cadmium plated steel and other metals or coatings which produce highly toxic fumes keep exposure as low as possible and below Threshold Limit Values (TLV) using local exhaust or mechanical ventilation. In confined spaces or in some circumstances, outdoors, a respirator may be required. Additional precautions are also required when welding on galvanized steel.**

3.b. Do not use plasma arc cutting or gouging in locations near chlorinated hydrocarbon vapors coming from degreasing, cleaning or spraying operations. The heat and rays of the arc can react with solvent vapors to form phosgene, a highly toxic gas, and other irritating products.

3.c. Gases used for plasma cutting and gouging can displace air and cause injury or death. Always use enough ventilation, especially in confined areas, to insure breathing air is safe.

3.d. Read and understand the manufacturer's instructions for this equipment and the consumables to be used, including the material safety data sheet (MSDS) and follow your employer's safety practices.

**CUTTING SPARKS can cause fire or explosion.**

4.a. Remove fire hazards from the plasma cutting or gouging area. If this is not possible, cover them to prevent the cutting or gouging sparks from starting a fire. Remember that welding sparks and hot materials from plasma cutting or gouging can easily go through small cracks and openings to adjacent areas. Avoid cutting or gouging near hydraulic lines. Have a fire extinguisher readily available.

4.b. Where compressed gases are to be used at the job site, special precautions should be used to prevent hazardous situations. Refer to "Safety in Welding and Cutting" (ANSI Standard Z49.1) and the operating information for the equipment being used.

4.c. When not cutting or gouging, make certain no part of the electrode circuit is touching the work or ground. Accidental contact can cause overheating and create a fire hazard.

4.d. Do not cut or gouge tanks, drums or containers until the proper steps have been taken to insure that such procedures will not cause flammable or toxic vapors from substances inside. They can cause an explosion even though they have been "cleaned." For information purchase "Recommended Safe Practices for the Preparation for Welding and Cutting of Containers and Piping That Have Held Hazardous Substances", AWS F4.1 from the American Welding Society (see address above).

4.e. Vent hollow castings or containers before heating, cutting or gouging. They may explode.

4.f. Do not fuel engine driven equipment near area where plasma cutting or gouging.

**ARC RAYS can burn.**

2.a. Use safety glasses and a shield with the proper filter and cover plates to protect your eyes from sparks and the rays of the arc when performing or observing plasma arc cutting or gouging. Glasses, headshield and filter lens should conform to ANSI Z87.1 standards.

2.b. Use suitable clothing including gloves made from durable flame-resistant material to protect your skin and that of your helpers from the arc rays.

2.c. Protect other nearby personnel with suitable non-flammable screening and/or warn them not to watch the arc nor expose themselves to the arc rays or to hot spatter or metal.

- 4.g. Sparks and spatter are thrown from the plasma arc. Wear safety glasses, ear protection and oil free protective garments such as leather gloves, heavy shirt, cuffless trousers, high shoes and a cap over your hair. Wear ear plugs when cutting or gouging out of position or in confined places. Always wear safety glasses with side shields when in a cutting or gouging area.
- 4.h. Connect the work cable to the work as close to the cutting or gouging area as practical. Work cables connected to the building framework or other locations away from the cutting or gouging area increase the possibility of the current passing through lifting chains, crane cables or other alternate circuits. This can create fire hazards or overheat lifting chains or cables until they fail.

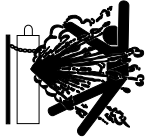

### CYLINDER may explode if damaged.

5.a. Use only compressed gas cylinders containing the correct gas for the process used and properly operating regulators designed for the gas and pressure used. All hoses, fittings, etc.

should be suitable for the application and maintained in good condition.

- 5.b. Always keep cylinders in an upright position securely chained to an undercarriage or fixed support.
- 5.c. Cylinders should be located:
- Away from areas where they may be struck or subjected to physical damage.
  - A safe distance from plasma cutting or gouging, arc welding operations and any other source of heat, sparks, or flame.
- 5.d. Never allow any part of the electrode, torch or any other electrically "hot" parts to touch a cylinder.
- 5.e. Keep your head and face away from the cylinder valve outlet when opening the cylinder valve.
- 5.f. Valve protection caps should always be in place and hand tight except when the cylinder is in use or connected for use.
- 5.g. Read and follow the instructions on compressed gas cylinders, associated equipment, and CGA publication P-1, "Precautions for Safe Handling of Compressed Gases in Cylinders," available from the Compressed Gas Association 1235 Jefferson Davis Highway, Arlington, VA 22202.



### FOR ELECTRICALLY powered equipment.

6.a. Turn off input power using the disconnect switch at the fuse box before working on the equipment.

- 6.b. Install equipment in accordance with the U.S. National Electrical Code, all local codes and the manufacturer's recommendations.
- 6.c. Ground the equipment in accordance with the U.S. National Electrical Code and the manufacturer's recommendations.



### PLASMA ARC can injure.

7.a. Keep your body away from nozzle and plasma arc.

7.b. Operate the pilot arc with caution. The pilot arc is capable of burning the operator, others or even piercing safety clothing.



### ELECTRIC AND MAGNETIC FIELDS may be dangerous

8.a. Electric current flowing through any conductor causes localized Electric and Magnetic Fields (EMF). Cutting or gouging current creates EMF fields around torch cables and cutting machines.

8.b. EMF fields may interfere with some pacemakers, so operators having a pacemaker should consult their physician before cutting or gouging.

- 8.c. Exposure to EMF fields during cutting or gouging may have other health effects which are now not known.
- 8d. All operators should use the following procedures in order to minimize exposure to EMF fields from the cutting or gouging circuit:
- 8.d.1. Route the torch and work cables together - Secure them with tape when possible.
  - 8.d.2. Never coil the torch cable around your body.
  - 8.d.3. Do not place your body between the torch and work cables. If the torch cable is on your right side, the work cable should also be on your right side.
  - 8.d.4. Connect the work cable to the workpiece as close as possible to the area being cut or gouged.
  - 8.d.5. Do not work next to cutting power source.

Apr. '93

# NOTES

## PRÉCAUTIONS DE SÛRETÉ

Pour votre propre protection lire et observer toutes les instructions et les précautions de sûreté spécifiques qui paraissent dans ce manuel aussi bien que les précautions de sûreté générales suivantes:

### Sûreté Pour Soudage A L'Arc

1. Protégez-vous contre la secousse électrique:
  - a. Les circuits à l'électrode et à la pièce sont sous tension quand la machine à souder est en marche. Eviter toujours tout contact entre les parties sous tension et la peau nue ou les vêtements mouillés. Porter des gants secs et sans trous pour isoler les mains.
  - b. Faire très attention de bien s'isoler de la masse quand on soude dans des endroits humides, ou sur un plancher métallique ou des grilles métalliques, principalement dans les positions assis ou couché pour lesquelles une grande partie du corps peut être en contact avec la masse.
  - c. Maintenir le porte-électrode, la pince de masse, le câble de soudage et la machine à souder en bon et sûr état de fonctionnement.
  - d. Ne jamais plonger le porte-électrode dans l'eau pour le refroidir.
  - e. Ne jamais toucher simultanément les parties sous tension des porte-électrodes connectés à deux machines à souder parce que la tension entre les deux pinces peut être le total de la tension à vide des deux machines.
  - f. Si on utilise la machine à souder comme une source de courant pour soudage semi-automatique, ces précautions pour le porte-électrode s'appliquent aussi au pistolet de soudage.
2. Dans le cas de travail au dessus du niveau du sol, se protéger contre les chutes dans le cas où on reçoit un choc. Ne jamais enrouler le câble-électrode autour de n'importe quelle partie du corps.
3. Un coup d'arc peut être plus sévère qu'un coup de soleil, donc:
  - a. Utiliser un bon masque avec un verre filtrant approprié ainsi qu'un verre blanc afin de se protéger les yeux du rayonnement de l'arc et des projections quand on soude ou quand on regarde l'arc.
  - b. Porter des vêtements convenables afin de protéger la peau de soudeur et des aides contre le rayonnement de l'arc.
  - c. Protéger l'autre personnel travaillant à proximité au soudage à l'aide d'écrans appropriés et non-inflammables.
4. Des gouttes de laitier en fusion sont émises de l'arc de soudage. Se protéger avec des vêtements de protection libres de l'huile, tels que les gants en cuir, chemise épaisse, pantalons sans revers, et chaussures montantes.
5. Toujours porter des lunettes de sécurité dans la zone de soudage. Utiliser des lunettes avec écrans latéraux dans les zones où l'on pique le laitier.

6. Eloigner les matériaux inflammables ou les recouvrir afin de prévenir tout risque d'incendie dû aux étincelles.
7. Quand on ne soude pas, poser la pince à un endroit isolé de la masse. Un court-circuit accidentel peut provoquer un échauffement et un risque d'incendie.
8. S'assurer que la masse est connectée le plus près possible de la zone de travail qu'il est pratique de le faire. Si on place la masse sur la charpente de la construction ou d'autres endroits éloignés de la zone de travail, on augmente le risque de voir passer le courant de soudage par les chaînes de levage, câbles de grue, ou autres circuits. Cela peut provoquer des risques d'incendie ou d'échauffement des chaînes et des câbles jusqu'à ce qu'ils se rompent.
9. Assurer une ventilation suffisante dans la zone de soudage. Ceci est particulièrement important pour le soudage de tôles galvanisées plombées, ou cadmiées ou tout autre métal qui produit des fumeés toxiques.
10. Ne pas souder en présence de vapeurs de chlore provenant d'opérations de dégraissage, nettoyage ou pistolage. La chaleur ou les rayons de l'arc peuvent réagir avec les vapeurs du solvant pour produire du phosgène (gas fortement toxique) ou autres produits irritants.
11. Pour obtenir de plus amples renseignements sur la sûreté, voir le code "Code for safety in welding and cutting" CSA Standard W 117.2-1974.

## PRÉCAUTIONS DE SÛRETÉ POUR LES MACHINES À SOUDER À TRANSFORMATEUR ET À REDRESSEUR

1. Relier à la terre le châssis du poste conformément au code de l'électricité et aux recommandations du fabricant. Le dispositif de montage ou la pièce à souder doit être branché à une bonne mise à la terre.
2. Autant que possible, l'installation et l'entretien du poste seront effectués par un électricien qualifié.
3. Avant de faire des travaux à l'intérieur de poste, la débrancher à l'interrupteur à la boîte de fusibles.
4. Garder tous les couvercles et dispositifs de sûreté à leur place.

Mar. '93

# Thank You

for selecting a **QUALITY** product by Lincoln Electric. We want you to take pride in operating this Lincoln Electric Company product ••• as much pride as we have in bringing this product to you!

## **Please Examine Carton and Equipment For Damage Immediately**

When this equipment is shipped, title passes to the purchaser upon receipt by the carrier. Consequently, Claims for material damaged in shipment must be made by the purchaser against the transportation company at the time the shipment is received.

Please record your equipment identification information below for future reference. This information can be found on your machine nameplate.

Product \_\_\_\_\_

Model Number \_\_\_\_\_

Code Number or Date Code \_\_\_\_\_

Serial Number \_\_\_\_\_

Date Purchased \_\_\_\_\_

Where Purchased \_\_\_\_\_

Whenever you request replacement parts or information on this equipment, always supply the information you have recorded above. The code number is especially important when identifying the correct replacement parts.

## **On-Line Product Registration**

- Register your machine with Lincoln Electric either via fax or over the Internet.
- For faxing: Complete the form on the back of the warranty statement included in the literature packet accompanying this machine and fax the form per the instructions printed on it.
- For On-Line Registration: Go to our **WEB SITE at [www.lincolnelectric.com](http://www.lincolnelectric.com)**. Choose "Quick Links" and then "Product Registration". Please complete the form and submit your registration.

**Read this Operators Manual completely** before attempting to use this equipment. Save this manual and keep it handy for quick reference. Pay particular attention to the safety instructions we have provided for your protection. The level of seriousness to be applied to each is explained below:

### **⚠ WARNING**

This statement appears where the information **must** be followed **exactly** to avoid **serious personal injury** or **loss of life**.

### **⚠ CAUTION**

This statement appears where the information **must** be followed to avoid **minor personal injury** or **damage to this equipment**.

PLASMA TORCH



---

## TABLE OF CONTENTS

	Page
SPECIFICATION SUMMARY .....	A-1
GENERAL DESCRIPTION .....	A-2
INSTALLATION.....	A-2
OPERATION.....	B-1
MAINTENANCE .....	C-1
TORCH HEAD AND CABLE REPLACEMENT.....	C-2
TROUBLESHOOTING .....	D-1
PARTS PAGES .....	P210-C,-G

---

## SPECIFICATIONS SUMMARY

TYPE				
<ul style="list-style-type: none"> <li>▲ K880-1 PCT125 Hand-held Plasma Torch with 25 ft. (7.6m) cable</li> <li>▲ K880-2 PCT125 Hand-held Plasma Torch with 50 ft. (15.2m) cable</li> <li>▲ K880-3 PCT125M Plasma Machine Torch with 50 ft (15.2m) cable and 24 and 32 pitch gear racks</li> <li>▲ K880-4 PCT125M Robotic Plasma Torch with 50 ft (15.2m) cable</li> <li>K880-5 PCT125 Hand-held Plasma Torch with 25 ft. (7.6m) cable</li> </ul>				
OUTPUT RATING				
<p>125 Amps, 60% Duty Cycle 100 Amps, 100% Duty Cycle</p>				
NET WEIGHT				
<ul style="list-style-type: none"> <li>▲ K880-1 PCT125 Hand-held Plasma Torch with 25 ft. (7.6m) cable, 11.5 lbs (5.2 kg)</li> <li>▲ K880-2 PCT125 Hand-held Plasma Torch with 50 ft. (15.2m) cable, 21.5 lbs (9.8 kg)</li> <li>▲ K880-3 PCT125M Plasma Machine Torch with 50 ft. (15.2m) cable, 21.5 lbs (9.8 kg)</li> <li>▲ K880-4 PCT125M Robotic Plasma Torch with 50 ft. (15.2m) cable, 21.5 lbs (9.8 kg)</li> <li>K880-5 PCT125 Hand-held Plasma Torch with 25 ft. (7.6m) cable, 12.0 lbs. (5.4 kg)</li> </ul>				
TORCH COMPONENTS				
Torch	Electrode	Swirl Ring	Nozzle	Cup
K880-1 K880-2 K880-3 K880-4	KP2043-1B1	KP2044-1	KP2042-1B1 .055" (1.4 mm) orifice KP2042-2B1 .067" (1.7 mm) orifice KP2042-3B1 .075" (1.9 mm) orifice KP2042-4B1 .118" (3.0 mm) orifice for gouging	KP2045-1 Shield Cup with optional KP2046-1 standoff guide or optional KP2047-1 gouging attachment.  S19974 Contact Cutting Attachment with required S19973 Contact Cutting Insulator.
K880-5	KP2043-1B1	KP2044-1	KP2042-1B1 .055" (1.4 mm) orifice KP2042-2B1 .067" (1.7 mm) orifice KP2042-3B1 .075" (1.9 mm) orifice KP2042-4B1 .118" (3.0 mm) orifice for gouging	KP2045-1 or -2 Shield Cup with optional KP2046-1 standoff guide or optional KP2047-1 gouging attachment.  S19974 Contact Cutting Attachment with required S19973 or S19973-1 Contact Cutting Insulator.

**Option Kits**    K881-1 Spare Parts Kit  
                       K952-1 Robotic/Machine Torch Retrofit Kit (required when using a machine torch with a machine code 10119 or below.)

▲ Torch is no longer available.

## PLASMA TORCH





## GENERAL DESCRIPTION

The Magnum PCT125/PCT125M plasma torches have been designed for use on a Pro-Cut 125. All of the torches are single gas, air-cooled. The torches are supplied factory mounted to the Pro-Cut or can be bought as individual units.

The hand-held torch is available only with a 70° head. It is supplied with either a 25 ft (7.6m) or 50 ft (15.2m) cable.

Two styles of mechanized torches are available. The robotic torch features an 8" (203mm) long, 1-5/8" (42.3mm) diameter barrel. The machine torch has a 12" (305mm) long, 1-3/8" (34.9mm) diameter barrel with a 32 pitch gear rack. The 32 pitch gear rack can be easily substituted with a 24 pitch gear rack which is included with the machine torch. The mechanized torches are offered only with 50 ft (15.2m) cables. Included with all mechanized torches is a 25 ft (7.6m) arc starter switch assembly for triggering the Pro-Cut without the use of an interface kit.

CNC or Robotic interface kits are available as a field installed option for those customer desiring automated plasma cutting. The kits provide remote triggering, remote output control and give a signal once a cutting arc has been established.

All of the plasma torches use the same consumables. In order to operate, a torch must have an electrode, swirl ring, nozzle and shield cup. There are three cutting nozzles available to give optimum arc performance at low, medium and high output. A gouging nozzle is also available. Drag cutting can be done by placing a wire standoff guide on to the shield cup or by using a contact cutting attachment and contact cutting insulator in place of the shield cup.

Operation from bottled compressed air or gas cylinders is not recommended due to the large volume of gas required for plasma cutting.

## INSTALLATION

### ⚠ WARNING



#### ELECTRIC SHOCK can kill.

- Only qualified personnel should perform this installation.
- Turn the input power OFF at the disconnect switch or fuse box before working on this equipment.
- Do not touch electrically hot parts.
- Do not operate with covers removed.

#### TOOLS REQUIRED:

5/16" nut driver  
5/8" open end wrench  
channel locks

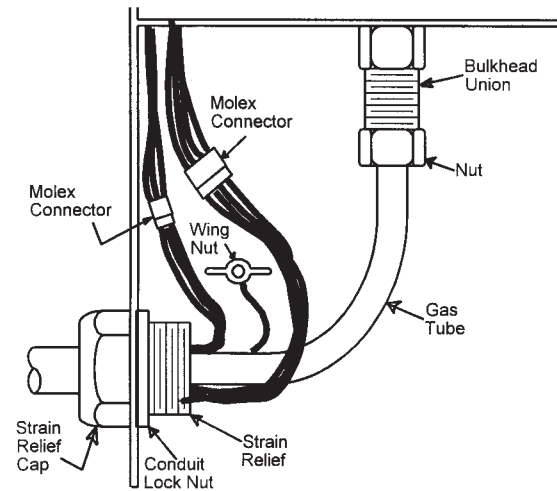

**FIGURE A.1 — Torch Connections.**

- Turn off power to the Pro-Cut at the disconnect switch or fuse box. Do not proceed until the power is definitely turned off.
- Using a 5/16" nut driver, remove the sheet metal screw which holds the access door shut on the right side of the Pro-Cut. Open the door.
- To remove a torch from the Pro-Cut, refer to Figure A.1 and do the following:
  - Separate the two molex connectors from torch to the Pro-Cut.
  - Using a 5/8" open end wrench, loosen and unscrew the nut securing the gas tube to the bulkhead union.

PLASMA TORCH



3. Unscrew the wing nut and remove the pilot lead of the torch cable from the pilot stud.
4. Loosen the strain relief cap using channel locks if necessary. Then loosen and unscrew the strain relief from the conduit lock nut.
5. Slide the cable through the conduit lock nut and out through the hole in the case front.

D. To assemble a torch to the Pro-Cut:

1. Slide the end of the cable through the hole in the case front. Then slide the conduit lock nut over the end of the cable.
2. With a 5/8" wrench tighten the fitting at the end of the gas tube onto the bulkhead union.
3. Place the ring lug of the pilot leads from the cable over the pilot stud. Place the wing nut on the pilot stud and tighten.
4. Connect the two moxex connectors from the torch to the moxex connectors in the Pro-Cut.
5. Loosen the cap on the strain relief. Slide the strain relief into the hole in the case front. Screw the conduit lock nut on to the strain relief and tighten the strain relief with channel locks. Hand tighten the strain relief cap and then tighten the cap an additional 1/2 turn with channel locks.

6. For mechanized torches only: (See diagram below)

**Without an interface kit**

Remove the top cover by loosening the sheet metal screws with a 5/16" nut driver. Remove the black hole plug from the left side of the front panel of the Pro-Cut. Disconnect the Pro-Cut's wiring harness at J5 in the lower right corner of the control board mounted on the center panel. Insert the plug and lead assembly (moxex jumper that came with the mechanized torch) into J5 on the control board. Plug the Pro-Cut's wiring harness plug into the jumper. Mount the strain relief to the front panel of the Pro-Cut. Insert the arc starter cable (terminals first) into the Pro-Cut and connect the cable to the plug and lead assembly. Tighten the strain relief onto the arc starter cable. Replace the top cover and insert the sheet metal screws.

- E. Close the access door and screw in the sheet metal screw with a 5/16" nut driver.
- F. Restore power to the Pro-Cut.

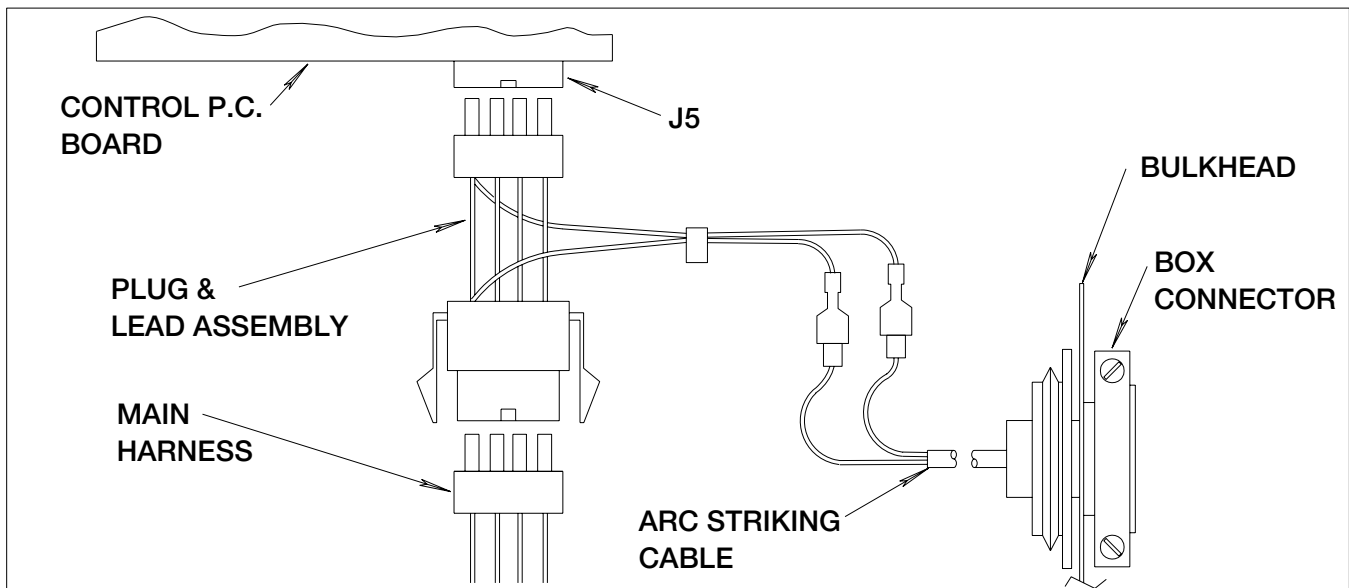

PLASMA TORCH



## OPERATION

Refer to your Pro-Cut operator's manual for complete operating information.

### WARNING

**When plasma cutting, it is necessary to wear proper eye, head and body protection.**

---

- A. Connect the work lead to the material to be cut.
- B. Assemble an electrode, swirl ring, nozzle and shield cup on the torch.
- C. Turn the Pro-Cut "ON" with the power switch on the front of the Pro-Cut.
- D. Flip the Run/Purge switch to PURGE. Adjust the regulator until the pressure gage reads 55-65 psi (379-448 kPa.) Flip the Run/Purge switch to RUN. Air will continue to flow for 60 seconds because the Pro-Cut will be in post flow.
- E. Adjust the output to the desired level. Refer to the appropriate Lincoln Process and Procedure Guidelines for recommended output, standoff, nozzle and cutting technique for your application.
- F. Activate the trigger.
  - If the air was not already flowing, the Pro-Cut will allow the air to flow for two seconds before the pilot arc is started. This is called PREFLOW.
  - If the trigger was activated during the first twelve seconds of postflow then a pilot arc will start instantly.
  - To start an arc after the first twelve seconds of postflow it will be necessary to perform a double trigger pull consisting of activating, releasing and activating the triggering within a one second period.
- G. Bring the pilot arc close to the material to be cut. Once the torch is about 1/8" to 1/4" (3 mm to 6 mm) away from the work piece the arc will automatically transfer to the work and the Pro-Cut will regulate output to the setting on the dial (or to the signal from an interface kit.) It is best to minimize the pilot arc time in order to prolong consumable life. Starting at the edge of the work piece instead of piercing the material increases consumable life also.
- H. Release the trigger when the cut is complete. Air will continue to flow for 60 seconds to cool the torch. This is called POSTFLOW.

## MAINTENANCE

### WARNING



#### **ELECTRIC SHOCK CAN KILL**

- Only qualified personnel should perform this installation.
- Turn the input power OFF at the disconnect switch or fuse box before working on this equipment.
- Do not touch electrically hot parts.
- Do not operate with covers removed.

Keep the work area clean and free of combustible materials. Prevent debris and objects from obstructing air flow around the Pro-Cut.

Every few months, blow the dust off the air intakes and louvers with compressed air.

Check the filter elements every several months to see if they are clogged (weekly in very dirty environments). Replace if necessary.

Inspect the cable periodically for any slits or puncture marks in the cable jacket. Replace if necessary. Check to make sure that nothing is crushing the cable and blocking the flow of air through the air tube inside. Also, check for kinks in the cable and relieve any so as not to restrict the flow of air to the torch.

Replace the electrode when the pit in the center of the electrode is deeper than .050" (1.3 mm) or when the copper portion is severely distorted.

Replace the nozzle when the orifice is no longer round or when the inside surface is covered with scale.

Green colored arcs indicate the electrode and/or nozzle are worn and need to be replaced.

PLASMA TORCH

**LINCOLN**<sup>®</sup>  
**ELECTRIC**

## REPLACEMENT INSTRUCTIONS FOR PCT125M CABLE AND TORCH HEAD ASSEMBLY

### ⚠ WARNING



**ELECTRIC SHOCK can kill.**

- Turn the input power off to the Pro-Cut using the disconnect switch at the fuse box before attempting to replace either the torch head or the cable assembly.
- Only qualified personnel should install, service or use this equipment.
- Read instructions thoroughly before beginning.

#### Tools Required:

two 5/8" open end wrenches  
7/16" open end wrench  
channel locks  
roll of electrical tape  
5/64" Allen wrench  
9/64" Allen wrench  
small flat bladed screwdriver

NOTE: The pictures illustrate the robotic torch. The procedure for replacing components on the machine torch is similar.

1. Be sure power is OFF to the machine by using the disconnect switch at the fuse box. Do not proceed until power to the machine is disconnected.
2. Use a small flat bladed screwdriver to relieve tension on the hose clamp around the boot. Remove the hose clamp from the torch.

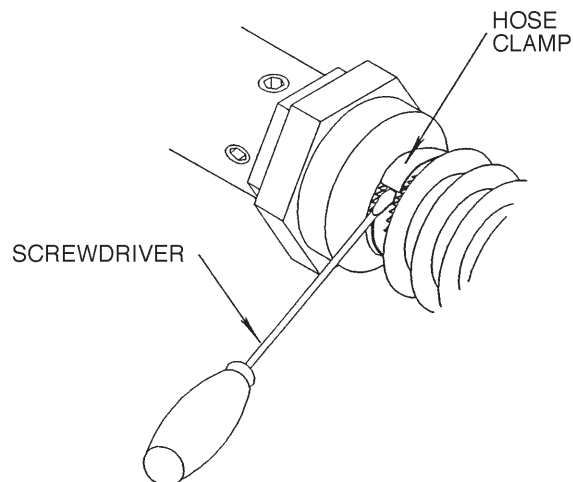

3. Loosen the strain relief cap using channel locks if necessary.

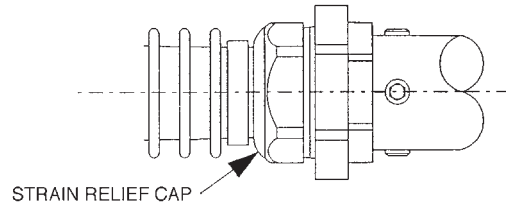

4. Remove the socket head screws holding the strain relief to the barrel with a 9/64" Allen wrench.

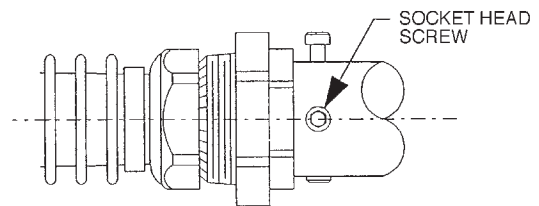

5. Slide the boot, strain relief cap and strain relief as a complete unit about one foot along the cable.

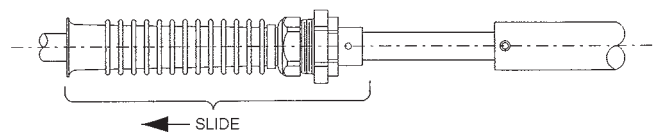

6. Use a 5/64" Allen wrench to remove the set screws securing the barrel to the torch head.

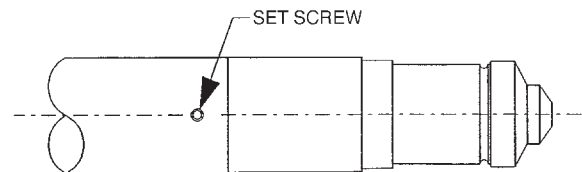

7. Slide the barrel and insulating tube along the cable to reveal the cable-to-torch head connections.

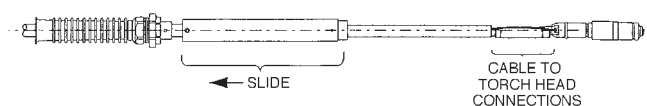

8. Using a flat bladed screwdriver, loosen and remove the screws securing the leads from the cable to the torch head.

PLASMA TORCH



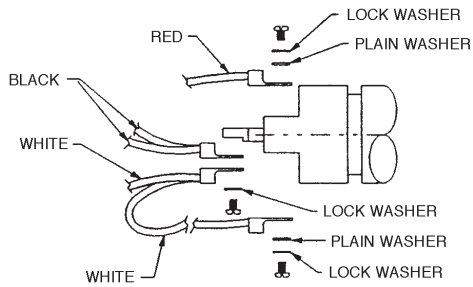

9. Untape and remove the insulation.

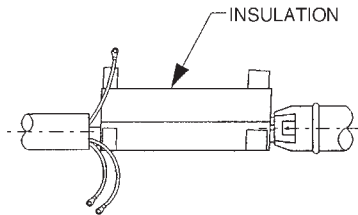

10. Separate the torch head from the cable using two 5/8" open end wrenches.

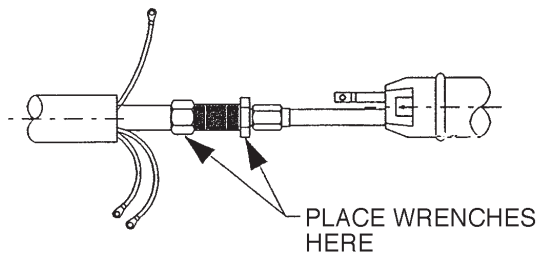

11. Replace the torch head or cable assembly as follows:

- a. To replace the torch head, remove the fitting from the old torch head by using a 5/8" open end wrench and a 7/16" open end wrench. Discard the old torch head and obtain a new torch head. Place the fitting on the new torch head and tighten with the wrenches.

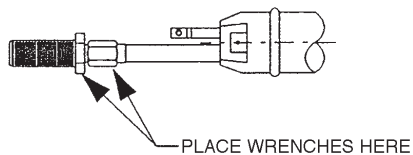

- b. For replacing the cable assembly, slide the insulating tube, barrel, strain relief and boot off of the old cable. Obtain a new cable and discard the old cable. If the boot becomes separated from the strain relief, insert the boot under the fingers of the strain relief before sliding the parts onto the new cable. Slide the following

parts on to the new cable in this order: Boot and strain relief, barrel, insulating tube.

12. Assemble the torch head to the cable and tighten the fittings using two 5/8" open end wrenches.

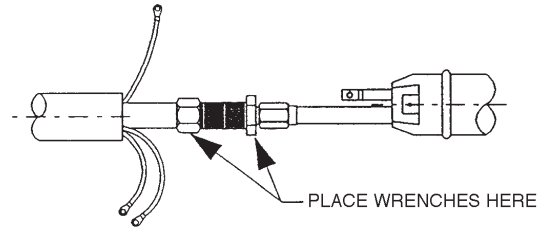

13. Attach the insulation sheet as follows:

- a. Use a piece of electrical tape to attach the insulation to the fitting. Center the insulation so that all of the fittings and the hose clamp will be completely covered.

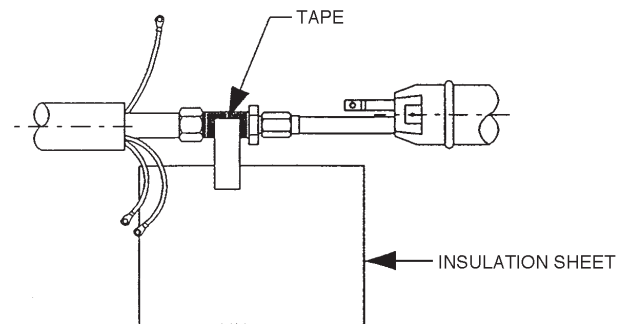

- b. Tightly wrap the insulation sheet around the fittings and underneath the stem for the pilot connection of the torch head. Secure the insulation in place with two pieces of electrical tape.

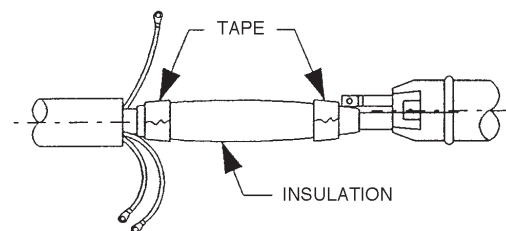

14. Assemble the leads from the cable to the torch head per the following diagram. It is not important which side of the torch head the red and the white lead mount.

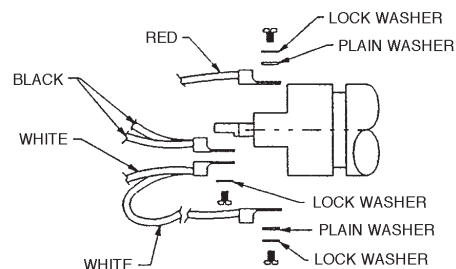

PLASMA TORCH

**LINCOLN**  
ELECTRIC

15. Slide the insulating tube over the cable and torch head connections to the back of the torch head and align the holes in the insulating tube with the holes in the torch head.

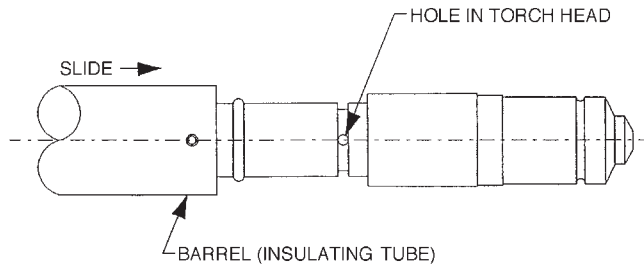

19. Place the hose clamp around the boot. Assemble the hose clamp such that it is snug around the boot.

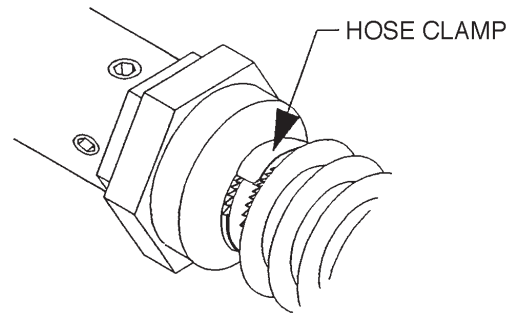

16. Slide the barrel over the insulating tube, aligning the holes in the barrel with the holes in the insulating tube. Secure the barrel and tube in place with the set screws and tighten with a 5/64" Allen wrench.

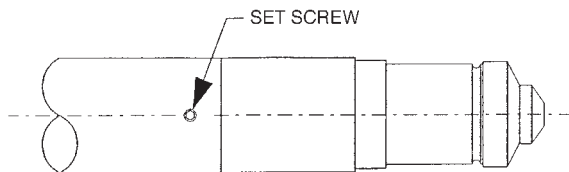

20. Restore power to the machine.

17. Slide the strain relief with the cable boot into the barrel. Do not allow the boot to slip out from underneath the fingers of the strain relief. Align the holes in the strain relief with the holes in the barrel. Secure the barrel to the strain relief with the socket head cap screws and tighten with a 9/64" Allen wrench.

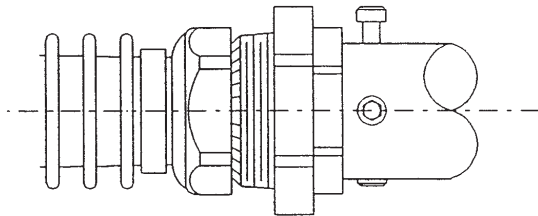

18. Tighten the strain relief cap hand tight and then tighten an additional half-turn with channel locks.

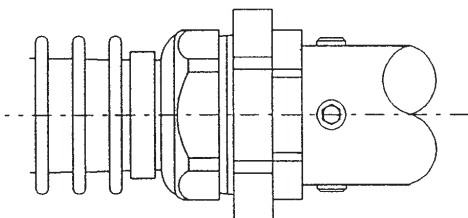

PLASMA TORCH

**LINCOLN**<sup>®</sup>  
**ELECTRIC**

## HOW TO USE TROUBLESHOOTING GUIDE

### WARNING

Service and Repair should only be performed by Lincoln Electric Factory Trained Personnel. Unauthorized repairs performed on this equipment may result in danger to the technician and machine operator and will invalidate your factory warranty. For your safety and to avoid Electrical Shock, please observe all safety notes and precautions detailed throughout this manual.

This Troubleshooting Guide is provided to help you locate and repair possible machine malfunctions. Simply follow the three-step procedure listed below.

#### **Step 1. LOCATE PROBLEM (SYMPTOM).**

Look under the column labeled “PROBLEM (SYMPTOMS)”. This column describes possible symptoms that the machine may exhibit. Find the listing that best describes the symptom that the machine is exhibiting.

#### **Step 2. POSSIBLE CAUSE.**

The second column labeled “POSSIBLE CAUSE” lists the obvious external possibilities that may contribute to the machine symptom.

#### **Step 3. RECOMMENDED COURSE OF ACTION**

This column provides a course of action for the Possible Cause, generally it states to contact your local Lincoln Authorized Field Service Facility.

If you do not understand or are unable to perform the Recommended Course of Action safely, contact your local Lincoln Authorized Field Service Facility.

### CAUTION

If for any reason you do not understand the test procedures or are unable to perform the tests/repairs safely, contact your **Local Lincoln Authorized Field Service Facility** for technical troubleshooting assistance before you proceed.

PLASMA TORCH





Observe all Safety Guidelines detailed throughout this manual

PROBLEMS (SYMPTOMS)	POSSIBLE CAUSE	RECOMMENDED COURSE OF ACTION
<b>FUNCTION PROBLEMS</b>		
<p>The torch does not start when the trigger is pulled</p>	<ul style="list-style-type: none"> <li>a. Blown fuse</li>   <li>b. Electrode or nozzle missing</li>   <li>c. Torch misconnected</li>   <li>d. Cable damaged</li>   <li>e. Torch connections assembled improperly or shorted</li>   <li>f. Pro-Cut inoperative</li> </ul>	<ul style="list-style-type: none"> <li>a. Make sure all three phases are present and the Pro-Cut is reconnected for the proper voltage.</li>   <li>b. Properly assemble an electrode, swirl ring, nozzle and shield cup on the torch.</li>   <li>c. Make sure the pilot lead from the torch cable is connected to the pilot stud inside the Pro-Cut. Verify that the fitting at the end of the gas tube is connected to the bulkhead union inside the Pro-Cut.</li>   <li>d. Examine the cable for cuts or punctures. Make sure there is continuity from the nozzle at the torch head to the ring lug at the end of the pilot lead at the machine end of the cable. Make sure there is continuity from the electrode at the torch head to the fitting at the end of the gas tube at the machine end of the cable. replace any damaged cable.</li>   <li>e. Remove the handles (or barrel) of the torch and examine all the connections. Pay attention to lugs crimped on insulation, broken leads.</li>   <li>f. Refer to the troubleshooting guide for the Pro-Cut 125.</li> </ul>

 **CAUTION**

If for any reason you do not understand the test procedures or are unable to perform the tests/repairs safely, contact your **Local Lincoln Authorized Field Service Facility** for technical troubleshooting assistance before you proceed.

**PLASMA TORCH**



Observe all Safety Guidelines detailed throughout this manual

PROBLEMS (SYMPTOMS)	POSSIBLE CAUSE	RECOMMENDED COURSE OF ACTION
<b>FUNCTION PROBLEMS</b>		
The Safety LED is lit	<ul style="list-style-type: none"> <li>a. The Pro-Cut was quickly turned “off” then “on” again.</li> <li>b. The shield cup is missing.</li> <li>c. The shield cup is not making contact with the pins of the torch head</li> <li>d. Torch misconnected</li> <li>e. Cable damaged</li> <li>f. Standoff too high</li> <li>g. Pro-Cut inoperative</li> </ul>	<ul style="list-style-type: none"> <li>a. Press the SAFETY RESET button.</li> <li>b. Make sure an electrode, swirl ring, nozzle and shield cup are all properly assembled on the torch.</li> <li>c. Verify that the spring loaded ring in the back of the shield cup is not jammed. Replace as necessary.</li> <li>d. Make sure the pilot lead from the torch cable is connected to the pilot stud inside the Pro-Cut. Verify that the fitting at the end of the gas tube is connected to the bulkhead union inside the Pro-Cut.</li> <li>e. Examine the cable for cuts or punctures. Make sure there is continuity from the nozzle at the torch head to the ring lug at the end of the pilot lead at the machine end of the cable. Make sure there is continuity from the electrode at the torch head to the fitting at the end of the gas tube at the machine end of the cable. Replace any damaged cable.</li> <li>f. Maintain a standoff of .15” to .25” during cutting. Too high of a standoff may trip the safety circuit..</li> <li>g. Refer to the troubleshooting guide for the Pro-Cut 125</li> </ul>

 **CAUTION**

If for any reason you do not understand the test procedures or are unable to perform the tests/repairs safely, contact your **Local Lincoln Authorized Field Service Facility** for technical troubleshooting assistance before you proceed.

**PLASMA TORCH**



Observe all Safety Guidelines detailed throughout this manual

PROBLEMS (SYMPTOMS)	POSSIBLE CAUSE	RECOMMENDED COURSE OF ACTION
<b>FUNCTION PROBLEMS</b>		
<p>Only a brief spurt of a Pilot Arc appears</p>	<p>a. Make sure the air pressure is set correctly</p> <p>b. Consumables may be improperly assembled.</p> <p>c. There may be oil in the air.</p> <p>d. The Pro-Cut may be in expanded metal mode.</p> <p>e. The swirl ring may have holes out of spec.</p> <p>f. The Pro-Cut is not working properly.</p>	<p>a. Put the Pro-Cut in Purge and adjust the air pressure to 55-65 psi while the air is flowing.</p> <p>b. Make sure an electrode, swirl ring, nozzle and shield cup are assembled in the torch.</p> <p>c. Check the filters in the regulators for oil. Replace if necessary and eliminate the source of oil.</p> <p>d. This is a normal condition which occurs after several long pilot arcs have been pulled in a row. After a while, the Pro-Cut will return to the standard pilot arc if no pilot arcs are pulled for several seconds.</p> <p>e. Some swirl rings were shipped with the swirl hole diameter too large. If possible, use plug gages to make sure the swirl hole diameter is not larger than .028".</p> <p>f. Refer to the troubleshooting guide for the Pro-Cut 125.</p>
<p>Electrode Stuck in Torch head</p>	<p>a. The duty cycle may have been exceeded</p> <p>b. Make sure the Pro-Cut has the larger solenoids (this applies to codes 10097 and lower only)</p> <p>c. Make sure the air pressure is set properly.</p>	<p>a. Operate the Pro-Cut within the duty cycle limits (125 Amps at 60%, 100 Amps at 100%.)</p> <p>b. Install a S21237 solenoid kit.</p> <p>c. Put the Pro-Cut in Purge and adjust the air pressure to 55-65 psi while the air is flowing.</p>

 **CAUTION**

If for any reason you do not understand the test procedures or are unable to perform the tests/repairs safely, contact your **Local Lincoln Authorized Field Service Facility** for technical troubleshooting assistance before you proceed.

PLASMA TORCH



# NOTES

---

PLASMA TORCH



# NOTES

---

PLASMA TORCH



# NOTES

---

PLASMA TORCH



			
<b>WARNING</b>	<ul style="list-style-type: none"> <li>Do not touch electrically live parts or electrode with skin or wet clothing.</li> <li>Insulate yourself from work and ground.</li> </ul>	<ul style="list-style-type: none"> <li>Keep flammable materials away.</li> </ul>	<ul style="list-style-type: none"> <li>Wear eye, ear and body protection.</li> </ul>
Spanish <b>AVISO DE PRECAUCION</b>	<ul style="list-style-type: none"> <li>No toque las partes o los electrodos bajo carga con la piel o ropa mojada.</li> <li>Aislese del trabajo y de la tierra.</li> </ul>	<ul style="list-style-type: none"> <li>Mantenga el material combustible fuera del área de trabajo.</li> </ul>	<ul style="list-style-type: none"> <li>Protéjase los ojos, los oídos y el cuerpo.</li> </ul>
French <b>ATTENTION</b>	<ul style="list-style-type: none"> <li>Ne laissez ni la peau ni des vêtements mouillés entrer en contact avec des pièces sous tension.</li> <li>Isolez-vous du travail et de la terre.</li> </ul>	<ul style="list-style-type: none"> <li>Gardez à l'écart de tout matériel inflammable.</li> </ul>	<ul style="list-style-type: none"> <li>Protégez vos yeux, vos oreilles et votre corps.</li> </ul>
German <b>WARNUNG</b>	<ul style="list-style-type: none"> <li>Berühren Sie keine stromführenden Teile oder Elektroden mit Ihrem Körper oder feuchter Kleidung!</li> <li>Isolieren Sie sich von den Elektroden und dem Erdboden!</li> </ul>	<ul style="list-style-type: none"> <li>Entfernen Sie brennbares Material!</li> </ul>	<ul style="list-style-type: none"> <li>Tragen Sie Augen-, Ohren- und Körperschutz!</li> </ul>
Portuguese <b>ATENÇÃO</b>	<ul style="list-style-type: none"> <li>Não toque partes elétricas e electrodos com a pele ou roupa molhada.</li> <li>Isole-se da peça e terra.</li> </ul>	<ul style="list-style-type: none"> <li>Mantenha inflamáveis bem guardados.</li> </ul>	<ul style="list-style-type: none"> <li>Use proteção para a vista, ouvido e corpo.</li> </ul>
Japanese <b>注意事項</b>	<ul style="list-style-type: none"> <li>通電中の電気部品、又は溶材にヒブやぬれた布で触れないこと。</li> <li>施工物やアースから身体が絶縁されている様にして下さい。</li> </ul>	<ul style="list-style-type: none"> <li>燃えやすいものの側での溶接作業は絶対にはなりません。</li> </ul>	<ul style="list-style-type: none"> <li>目、耳及び身体に保護具をして下さい。</li> </ul>
Chinese <b>警告</b>	<ul style="list-style-type: none"> <li>皮肤或湿衣物切勿接触带电部件及焊条。</li> <li>使你自已与地面和工件绝缘。</li> </ul>	<ul style="list-style-type: none"> <li>把一切易燃物品移离工作场所。</li> </ul>	<ul style="list-style-type: none"> <li>佩戴眼、耳及身体劳动保护用具。</li> </ul>
Korean <b>위험</b>	<ul style="list-style-type: none"> <li>전도체나 용접봉을 젖은 헝겍 또는 피부로 절대 접촉치 마십시오.</li> <li>모재와 접지를 접촉치 마십시오.</li> </ul>	<ul style="list-style-type: none"> <li>인화성 물질을 접근 시키지 마십시오.</li> </ul>	<ul style="list-style-type: none"> <li>눈, 귀와 몸에 보호장구를 착용하십시오.</li> </ul>
Arabic <b>تحذير</b>	<ul style="list-style-type: none"> <li>لا تلمس الاجزاء التي يسري فيها التيار الكهربائي أو الإلكترود بجسدك أو بالملابس المبللة بالماء.</li> <li>ضع عازلا على جسمك خلال العمل.</li> </ul>	<ul style="list-style-type: none"> <li>ضع المواد القابلة للاشتعال في مكان بعيد.</li> </ul>	<ul style="list-style-type: none"> <li>ضع أدوات وملابس واقية على عينيك وأذنيك وجسمك.</li> </ul>

**READ AND UNDERSTAND THE MANUFACTURER'S INSTRUCTION FOR THIS EQUIPMENT AND THE CONSUMABLES TO BE USED AND FOLLOW YOUR EMPLOYER'S SAFETY PRACTICES.**

**SE RECOMIENDA LEER Y ENTENDER LAS INSTRUCCIONES DEL FABRICANTE PARA EL USO DE ESTE EQUIPO Y LOS CONSUMIBLES QUE VA A UTILIZAR, SIGA LAS MEDIDAS DE SEGURIDAD DE SU SUPERVISOR.**

**LISEZ ET COMPRENEZ LES INSTRUCTIONS DU FABRICANT EN CE QUI REGARDE CET EQUIPMENT ET LES PRODUITS A ETRE EMPLOYES ET SUIVEZ LES PROCEDURES DE SECURITE DE VOTRE EMPLOYEUR.**

**LESEN SIE UND BEFOLGEN SIE DIE BETRIEBSANLEITUNG DER ANLAGE UND DEN ELEKTRODENEINSATZ DES HERSTELLERS. DIE UNFALLVERHÜTUNGSVORSCHRIFTEN DES ARBEITGEBERS SIND EBENFALLS ZU BEACHTEN.**

PLASMA TORCH



			
<ul style="list-style-type: none"> <li>● Keep your head out of fumes.</li> <li>● Use ventilation or exhaust to remove fumes from breathing zone.</li> </ul>	<ul style="list-style-type: none"> <li>● Turn power off before servicing.</li> </ul>	<ul style="list-style-type: none"> <li>● Do not operate with panel open or guards off.</li> </ul>	<b>WARNING</b>
<ul style="list-style-type: none"> <li>● Los humos fuera de la zona de respiración.</li> <li>● Mantenga la cabeza fuera de los humos. Utilice ventilación o aspiración para gases.</li> </ul>	<ul style="list-style-type: none"> <li>● Desconectar el cable de alimentación de poder de la máquina antes de iniciar cualquier servicio.</li> </ul>	<ul style="list-style-type: none"> <li>● No operar con panel abierto o guardas quitadas.</li> </ul>	Spanish <b>AVISO DE PRECAUCION</b>
<ul style="list-style-type: none"> <li>● Gardez la tête à l'écart des fumées.</li> <li>● Utilisez un ventilateur ou un aspirateur pour ôter les fumées des zones de travail.</li> </ul>	<ul style="list-style-type: none"> <li>● Débranchez le courant avant l'entretien.</li> </ul>	<ul style="list-style-type: none"> <li>● N'opérez pas avec les panneaux ouverts ou avec les dispositifs de protection enlevés.</li> </ul>	French <b>ATTENTION</b>
<ul style="list-style-type: none"> <li>● Vermeiden Sie das Einatmen von Schweißrauch!</li> <li>● Sorgen Sie für gute Be- und Entlüftung des Arbeitsplatzes!</li> </ul>	<ul style="list-style-type: none"> <li>● Strom vor Wartungsarbeiten abschalten! (Netzstrom völlig öffnen; Maschine anhalten!)</li> </ul>	<ul style="list-style-type: none"> <li>● Anlage nie ohne Schutzgehäuse oder Innenschutzverkleidung in Betrieb setzen!</li> </ul>	German <b>WARNUNG</b>
<ul style="list-style-type: none"> <li>● Mantenha seu rosto da fumaça.</li> <li>● Use ventilação e exaustão para remover fumo da zona respiratória.</li> </ul>	<ul style="list-style-type: none"> <li>● Não opere com as tampas removidas.</li> <li>● Desligue a corrente antes de fazer serviço.</li> <li>● Não toque as partes elétricas nuas.</li> </ul>	<ul style="list-style-type: none"> <li>● Mantenha-se afastado das partes moventes.</li> <li>● Não opere com os painéis abertos ou guardas removidas.</li> </ul>	Portuguese <b>ATENÇÃO</b>
<ul style="list-style-type: none"> <li>● ヒュームから頭を離すようにして下さい。</li> <li>● 換気や排煙に十分留意して下さい。</li> </ul>	<ul style="list-style-type: none"> <li>● メンテナンス・サービスに取りかかる際には、まず電源スイッチを必ず切って下さい。</li> </ul>	<ul style="list-style-type: none"> <li>● パネルやカバーを取り外したままで機械操作をしないで下さい。</li> </ul>	Japanese <b>注意事項</b>
<ul style="list-style-type: none"> <li>● 頭部遠離煙霧。</li> <li>● 在呼吸區使用通風或排風器除煙。</li> </ul>	<ul style="list-style-type: none"> <li>● 維修前切斷電源。</li> </ul>	<ul style="list-style-type: none"> <li>● 儀表板打開或沒有安全罩時不準作業。</li> </ul>	Chinese <b>警告</b>
<ul style="list-style-type: none"> <li>● 얼굴로부터 용접가스를 멀리하십시오.</li> <li>● 호흡지역으로부터 용접가스를 제거하기 위해 가스제거기나 통풍기를 사용하십시오.</li> </ul>	<ul style="list-style-type: none"> <li>● 보수전에 전원을 차단하십시오.</li> </ul>	<ul style="list-style-type: none"> <li>● 판넬이 열린 상태로 작동치 마십시오.</li> </ul>	Korean <b>위험</b>
<ul style="list-style-type: none"> <li>● ابعء رأسك بعيداً عن الدخان.</li> <li>● استعمل التهوية أو جهاز ضغط الدخان للخارج لكي تبعد الدخان عن المنطقة التي تتنفس فيها.</li> </ul>	<ul style="list-style-type: none"> <li>● اقطع التيار الكهربائي قبل القيام بأية صيانة.</li> </ul>	<ul style="list-style-type: none"> <li>● لا تشغيل هذا الجهاز إذا كانت الاغطية الحديدية الواقية ليست عليه.</li> </ul>	Arabic <b>تحذير</b>

**LEIA E COMPREENDA AS INSTRUÇÕES DO FABRICANTE PARA ESTE EQUIPAMENTO E AS PARTES DE USO, E SIGA AS PRÁTICAS DE SEGURANÇA DO EMPREGADOR.**

使う機械や溶材のメーカーの指示書をよく読み、まず理解して下さい。そして貴社の安全規定に従って下さい。

請詳細閱讀並理解製造廠提供的說明以及應該使用的銀焊材料，並請遵守貴方的有關勞動保護規定。

이 제품에 동봉된 작업지침서를 숙지하시고 귀사의 작업자 안전수칙을 준수하시기 바랍니다.

اقرأ بتمعن وافهم تعليمات المصنع المنتج لهذه المعدات والمواد قبل استعمالها واتبع تعليمات الوقاية لصاحب العمل.

PLASMA TORCH







• World's Leader in Welding and Cutting Products •

• Sales and Service through Subsidiaries and Distributors Worldwide •

Cleveland, Ohio 44117-1199 U.S.A. TEL: 216.481.8100 FAX: 216.486.1751 WEB SITE: [www.lincolnelectric.com](http://www.lincolnelectric.com)