



Operator's Manual

POWER WAVE® AC/DC 1000® SD



For use with machines having Code Numbers:
12385



Register your machine:
www.lincolnelectric.com/register

Authorized Service and Distributor Locator:
www.lincolnelectric.com/locator

Save for future reference

Date Purchased

Code: (ex: 10859)

Serial: (ex: U1060512345)

Need Help? Call 1.888.935.3877
to talk to a Service Representative

Hours of Operation:
8:00 AM to 6:00 PM (ET) Mon. thru Fri.

After hours?
Use "Ask the Experts" at lincolnelectric.com
A Lincoln Service Representative will contact you
no later than the following business day.

For Service outside the USA:
Email: globalservice@lincolnelectric.com

THANK YOU FOR SELECTING A QUALITY PRODUCT BY LINCOLN ELECTRIC.

PLEASE EXAMINE CARTON AND EQUIPMENT FOR DAMAGE IMMEDIATELY

When this equipment is shipped, title passes to the purchaser upon receipt by the carrier. Consequently, Claims for material damaged in shipment must be made by the purchaser against the transportation company at the time the shipment is received.

SAFETY DEPENDS ON YOU

Lincoln arc welding and cutting equipment is designed and built with safety in mind. However, your overall safety can be increased by proper installation ... and thoughtful operation on your part.

DO NOT INSTALL, OPERATE OR REPAIR THIS EQUIPMENT WITHOUT READING THIS MANUAL AND THE SAFETY PRECAUTIONS CONTAINED THROUGHOUT. And, most importantly, think before you act and be careful.



WARNING

This statement appears where the information must be followed exactly to avoid serious personal injury or loss of life.



CAUTION

This statement appears where the information must be followed to avoid minor personal injury or damage to this equipment.



KEEP YOUR HEAD OUT OF THE FUMES.

DON'T get too close to the arc. Use corrective lenses if necessary to stay a reasonable distance away from the arc.

READ and obey the Material Safety Data Sheet (MSDS) and the warning label that appears on all containers of welding materials.

USE ENOUGH VENTILATION or exhaust at the arc, or both, to keep the fumes and gases from your breathing zone and the general area.

IN A LARGE ROOM OR OUTDOORS, natural ventilation may be adequate if you keep your head out of the fumes (See below).

USE NATURAL DRAFTS or fans to keep the fumes away from your face.

If you develop unusual symptoms, see your supervisor. Perhaps the welding atmosphere and ventilation system should be checked.

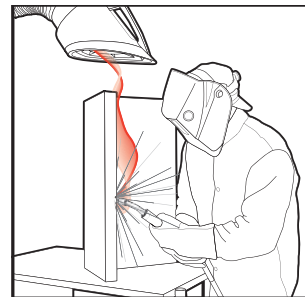

WEAR CORRECT EYE, EAR & BODY PROTECTION

PROTECT your eyes and face with welding helmet properly fitted and with proper grade of filter plate (See ANSI Z49.1).

PROTECT your body from welding spatter and arc flash with protective clothing including woolen clothing, flame-proof apron and gloves, leather leggings, and high boots.

PROTECT others from splatter, flash, and glare with protective screens or barriers.

IN SOME AREAS, protection from noise may be appropriate.

BE SURE protective equipment is in good condition.

Also, wear safety glasses in work area **AT ALL TIMES**.



SPECIAL SITUATIONS

DO NOT WELD OR CUT containers or materials which previously had been in contact with hazardous substances unless they are properly cleaned. This is extremely dangerous.

DO NOT WELD OR CUT painted or plated parts unless special precautions with ventilation have been taken. They can release highly toxic fumes or gases.

Additional precautionary measures

PROTECT compressed gas cylinders from excessive heat, mechanical shocks, and arcs; fasten cylinders so they cannot fall.

BE SURE cylinders are never grounded or part of an electrical circuit.

REMOVE all potential fire hazards from welding area.

ALWAYS HAVE FIRE FIGHTING EQUIPMENT READY FOR IMMEDIATE USE AND KNOW HOW TO USE IT.



SECTION A: WARNINGS



CALIFORNIA PROPOSITION 65 WARNINGS

Diesel Engines

Diesel engine exhaust and some of its constituents are known to the State of California to cause cancer, birth defects, and other reproductive harm.

Gasoline Engines

The engine exhaust from this product contains chemicals known to the State of California to cause cancer, birth defects, or other reproductive harm.

ARC WELDING CAN BE HAZARDOUS. PROTECT YOURSELF AND OTHERS FROM POSSIBLE SERIOUS INJURY OR DEATH. KEEP CHILDREN AWAY. PACE-MAKER WEARERS SHOULD CONSULT WITH THEIR DOCTOR BEFORE OPERATING.

Read and understand the following safety highlights. For additional safety information, it is strongly recommended that you purchase a copy of "Safety in Welding & Cutting - ANSI Standard Z49.1" from the American Welding Society, P.O. Box 351040, Miami, Florida 33135 or CSA Standard W117.2-1974. A Free copy of "Arc Welding Safety" booklet E205 is available from the Lincoln Electric Company, 22801 St. Clair Avenue, Cleveland, Ohio 44117-1199.

BE SURE THAT ALL INSTALLATION, OPERATION, MAINTENANCE AND REPAIR PROCEDURES ARE PERFORMED ONLY BY QUALIFIED INDIVIDUALS.



FOR ENGINE POWERED EQUIPMENT.

- 1.a. Turn the engine off before troubleshooting and maintenance work unless the maintenance work requires it to be running.
- 1.b. Operate engines in open, well-ventilated areas or vent the engine exhaust fumes outdoors.
- 1.c. Do not add the fuel near an open flame welding arc or when the engine is running. Stop the engine and allow it to cool before refueling to prevent spilled fuel from vaporizing on contact with hot engine parts and igniting. Do not spill fuel when filling tank. If fuel is spilled, wipe it up and do not start engine until fumes have been eliminated.



- 1.d. Keep all equipment safety guards, covers and devices in position and in good repair. Keep hands, hair, clothing and tools away from V-belts, gears, fans and all other moving parts when starting, operating or repairing equipment.



- 1.e. In some cases it may be necessary to remove safety guards to perform required maintenance. Remove guards only when necessary and replace them when the maintenance requiring their removal is complete. Always use the greatest care when working near moving parts.
- 1.f. Do not put your hands near the engine fan. Do not attempt to override the governor or idler by pushing on the throttle control rods while the engine is running.
- 1.g. To prevent accidentally starting gasoline engines while turning the engine or welding generator during maintenance work, disconnect the spark plug wires, distributor cap or magneto wire as appropriate.

- 1.h. To avoid scalding, do not remove the radiator pressure cap when the engine is hot.



ELECTRIC AND MAGNETIC FIELDS MAY BE DANGEROUS



- 2.a. Electric current flowing through any conductor causes localized Electric and Magnetic Fields (EMF). Welding current creates EMF fields around welding cables and welding machines
- 2.b. EMF fields may interfere with some pacemakers, and welders having a pacemaker should consult their physician before welding.
- 2.c. Exposure to EMF fields in welding may have other health effects which are now not known.
- 2.d. All welders should use the following procedures in order to minimize exposure to EMF fields from the welding circuit:
 - 2.d.1. Route the electrode and work cables together - Secure them with tape when possible.
 - 2.d.2. Never coil the electrode lead around your body.
 - 2.d.3. Do not place your body between the electrode and work cables. If the electrode cable is on your right side, the work cable should also be on your right side.
 - 2.d.4. Connect the work cable to the workpiece as close as possible to the area being welded.
 - 2.d.5. Do not work next to welding power source.



ELECTRIC SHOCK CAN KILL.



- 3.a. The electrode and work (or ground) circuits are electrically “hot” when the welder is on. Do not touch these “hot” parts with your bare skin or wet clothing. Wear dry, hole-free gloves to insulate hands.
- 3.b. Insulate yourself from work and ground using dry insulation. Make certain the insulation is large enough to cover your full area of physical contact with work and ground.

In addition to the normal safety precautions, if welding must be performed under electrically hazardous conditions (in damp locations or while wearing wet clothing; on metal structures such as floors, gratings or scaffolds; when in cramped positions such as sitting, kneeling or lying, if there is a high risk of unavoidable or accidental contact with the workpiece or ground) use the following equipment:

- Semiautomatic DC Constant Voltage (Wire) Welder.
 - DC Manual (Stick) Welder.
 - AC Welder with Reduced Voltage Control.
- 3.c. In semiautomatic or automatic wire welding, the electrode, electrode reel, welding head, nozzle or semiautomatic welding gun are also electrically “hot”.
 - 3.d. Always be sure the work cable makes a good electrical connection with the metal being welded. The connection should be as close as possible to the area being welded.
 - 3.e. Ground the work or metal to be welded to a good electrical (earth) ground.
 - 3.f. Maintain the electrode holder, work clamp, welding cable and welding machine in good, safe operating condition. Replace damaged insulation.
 - 3.g. Never dip the electrode in water for cooling.
 - 3.h. Never simultaneously touch electrically “hot” parts of electrode holders connected to two welders because voltage between the two can be the total of the open circuit voltage of both welders.
 - 3.i. When working above floor level, use a safety belt to protect yourself from a fall should you get a shock.
 - 3.j. Also see Items 6.c. and 8.



ARC RAYS CAN BURN.



- 4.a. Use a shield with the proper filter and cover plates to protect your eyes from sparks and the rays of the arc when welding or observing open arc welding. Headshield and filter lens should conform to ANSI Z87.1 standards.
- 4.b. Use suitable clothing made from durable flame-resistant material to protect your skin and that of your helpers from the arc rays.
- 4.c. Protect other nearby personnel with suitable, non-flammable screening and/or warn them not to watch the arc nor expose themselves to the arc rays or to hot spatter or metal.



FUMES AND GASES CAN BE DANGEROUS.



- 5.a. Welding may produce fumes and gases hazardous to health. Avoid breathing these fumes and gases. When welding, keep your head out of the fume. Use enough ventilation and/or exhaust at the arc to keep fumes and gases away from the breathing zone. **When welding with electrodes which require special ventilation such as stainless or hard facing (see instructions on container or MSDS) or on lead or cadmium plated steel and other metals or coatings which produce highly toxic fumes, keep exposure as low as possible and within applicable OSHA PEL and ACGIH TLV limits using local exhaust or mechanical ventilation. In confined spaces or in some circumstances, outdoors, a respirator may be required. Additional precautions are also required when welding on galvanized steel.**
- 5.b. The operation of welding fume control equipment is affected by various factors including proper use and positioning of the equipment, maintenance of the equipment and the specific welding procedure and application involved. Worker exposure level should be checked upon installation and periodically thereafter to be certain it is within applicable OSHA PEL and ACGIH TLV limits.
- 5.c. Do not weld in locations near chlorinated hydrocarbon vapors coming from degreasing, cleaning or spraying operations. The heat and rays of the arc can react with solvent vapors to form phosgene, a highly toxic gas, and other irritating products.
- 5.d. Shielding gases used for arc welding can displace air and cause injury or death. Always use enough ventilation, especially in confined areas, to insure breathing air is safe.
- 5.e. Read and understand the manufacturer's instructions for this equipment and the consumables to be used, including the material safety data sheet (MSDS) and follow your employer's safety practices. MSDS forms are available from your welding distributor or from the manufacturer.
- 5.f. Also see item 1.b.



WELDING AND CUTTING SPARKS CAN CAUSE FIRE OR EXPLOSION.

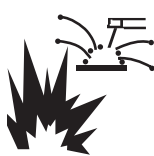

- 6.a. Remove fire hazards from the welding area. If this is not possible, cover them to prevent the welding sparks from starting a fire. Remember that welding sparks and hot materials from welding can easily go through small cracks and openings to adjacent areas. Avoid welding near hydraulic lines. Have a fire extinguisher readily available.
- 6.b. Where compressed gases are to be used at the job site, special precautions should be used to prevent hazardous situations. Refer to “Safety in Welding and Cutting” (ANSI Standard Z49.1) and the operating information for the equipment being used.
- 6.c. When not welding, make certain no part of the electrode circuit is touching the work or ground. Accidental contact can cause overheating and create a fire hazard.
- 6.d. Do not heat, cut or weld tanks, drums or containers until the proper steps have been taken to insure that such procedures will not cause flammable or toxic vapors from substances inside. They can cause an explosion even though they have been “cleaned”. For information, purchase “Recommended Safe Practices for the Preparation for Welding and Cutting of Containers and Piping That Have Held Hazardous Substances”, AWS F4.1 from the American Welding Society (see address above).
- 6.e. Vent hollow castings or containers before heating, cutting or welding. They may explode.
- 6.f. Sparks and spatter are thrown from the welding arc. Wear oil free protective garments such as leather gloves, heavy shirt, cuffless trousers, high shoes and a cap over your hair. Wear ear plugs when welding out of position or in confined places. Always wear safety glasses with side shields when in a welding area.
- 6.g. Connect the work cable to the work as close to the welding area as practical. Work cables connected to the building framework or other locations away from the welding area increase the possibility of the welding current passing through lifting chains, crane cables or other alternate circuits. This can create fire hazards or overheat lifting chains or cables until they fail.
- 6.h. Also see item 1.c.
- 6.i. Read and follow NFPA 51B “ Standard for Fire Prevention During Welding, Cutting and Other Hot Work”, available from NFPA, 1 Batterymarch Park, PO box 9101, Quincy, Ma 02269-9101.
- 6.j. Do not use a welding power source for pipe thawing.



CYLINDER MAY EXPLODE IF DAMAGED.

- 7.a. Use only compressed gas cylinders containing the correct shielding gas for the process used and properly operating regulators designed for the gas and pressure used. All hoses, fittings, etc. should be suitable for the application and maintained in good condition. 
- 7.b. Always keep cylinders in an upright position securely chained to an undercarriage or fixed support.
- 7.c. Cylinders should be located:
 - Away from areas where they may be struck or subjected to physical damage.
 - A safe distance from arc welding or cutting operations and any other source of heat, sparks, or flame.
- 7.d. Never allow the electrode, electrode holder or any other electrically “hot” parts to touch a cylinder.
- 7.e. Keep your head and face away from the cylinder valve outlet when opening the cylinder valve.
- 7.f. Valve protection caps should always be in place and hand tight except when the cylinder is in use or connected for use.
- 7.g. Read and follow the instructions on compressed gas cylinders, associated equipment, and CGA publication P-1, “Precautions for Safe Handling of Compressed Gases in Cylinders,” available from the Compressed Gas Association 1235 Jefferson Davis Highway, Arlington, VA 22202.



FOR ELECTRICALLY POWERED EQUIPMENT.



- 8.a. Turn off input power using the disconnect switch at the fuse box before working on the equipment.
- 8.b. Install equipment in accordance with the U.S. National Electrical Code, all local codes and the manufacturer’s recommendations.
- 8.c. Ground the equipment in accordance with the U.S. National Electrical Code and the manufacturer’s recommendations.

Refer to

<http://www.lincolnelectric.com/safety>

for additional safe-
ty information.

Welding Safety
Interactive Web Guide
for mobile devices



Get the free mobile app at
<http://gettag.mobi>

ELECTROMAGNETIC COMPATIBILITY (EMC)

CONFORMANCE

Products displaying the CE mark are in conformity with European Community Council Directive of 3 May 1989 on the approximation of the laws of the Member States relating to electromagnetic compatibility (89/336/EEC). It was manufactured in conformity with a national standard that implements a harmonized standard: EN 60974-10 Electromagnetic Compatibility (EMC) Product Standard for Arc Welding Equipment. It is for use with other Lincoln Electric equipment. It is designed for industrial and professional use.

INTRODUCTION

All electrical equipment generates small amounts of electromagnetic emission. Electrical emission may be transmitted through power lines or radiated through space, similar to a radio transmitter. When emissions are received by other equipment, electrical interference may result. Electrical emissions may affect many kinds of electrical equipment; other nearby welding equipment, radio and TV reception, numerical controlled machines, telephone systems, computers, etc. Be aware that interference may result and extra precautions may be required when a welding power source is used in a domestic establishment.

INSTALLATION AND USE

The user is responsible for installing and using the welding equipment according to the manufacturer's instructions. If electromagnetic disturbances are detected then it shall be the responsibility of the user of the welding equipment to resolve the situation with the technical assistance of the manufacturer. In some cases this remedial action may be as simple as earthing (grounding) the welding circuit, see Note. In other cases it could involve construction of an electromagnetic screen enclosing the power source and the work complete with associated input filters. In all cases electromagnetic disturbances must be reduced to the point where they are no longer troublesome.

Note: The welding circuit may or may not be earthed for safety reasons according to national codes. Changing the earthing arrangements should only be authorized by a person who is competent to access whether the changes will increase the risk of injury, e.g., by allowing parallel welding current return paths which may damage the earth circuits of other equipment.

ASSESSMENT OF AREA

Before installing welding equipment the user shall make an assessment of potential electromagnetic problems in the surrounding area. The following shall be taken into account:

- a. other supply cables, control cables, signaling and telephone cables; above, below and adjacent to the welding equipment;
- b. radio and television transmitters and receivers;
- c. computer and other control equipment;
- d. safety critical equipment, e.g., guarding of industrial equipment;
- e. the health of the people around, e.g., the use of pacemakers and hearing aids;
- f. equipment used for calibration or measurement
- g. the immunity of other equipment in the environment. The user shall ensure that other equipment being used in the environment is compatible. This may require additional protection measures;
- h. the time of day that welding or other activities are to be carried out.

The size of the surrounding area to be considered will depend on the structure of the building and other activities that are taking place. The surrounding area may extend beyond the boundaries of the premises.

METHODS OF REDUCING EMISSIONS

Mains Supply

Welding equipment should be connected to the mains supply according to the manufacturer's recommendations. If interference occurs, it may be necessary to take additional precautions such as filtering of the mains supply. Consideration should be given to shielding the supply cable of permanently installed welding equipment, in metallic conduit or equivalent. Shielding should be electrically continuous throughout its length. The shielding should be connected to the welding power source so that good electrical contact is maintained between the conduit and the welding power source enclosure.

Maintenance of the Welding Equipment

The welding equipment should be routinely maintained according to the manufacturer's recommendations. All access and service doors and covers should be closed and properly fastened when the welding equipment is in operation. The welding equipment should not be modified in any way except for those changes and adjustments covered in the manufacturer's instructions. In particular, the spark gaps of arc striking and stabilizing devices should be adjusted and maintained according to the manufacturer's recommendations.

Welding Cables

The welding cables should be kept as short as possible and should be positioned close together, running at or close to floor level.

Equipotential Bonding

Bonding of all metallic components in the welding installation and adjacent to it should be considered. However, metallic components bonded to the work piece will increase the risk that the operator could receive a shock by touching these metallic components and the electrode at the same time. The operator should be insulated from all such bonded metallic components.

Earthing of the Workpiece

Where the workpiece is not bonded to earth for electrical safety, not connected to earth because of its size and position, e.g., ships hull or building steelwork, a connection bonding the workpiece to earth may reduce emissions in some, but not all instances. Care should be taken to prevent the earthing of the work piece increasing the risk of injury to users, or damage to other electrical equipment. Where necessary, the connection of the workpiece to earth should be made by a direct connection to the work piece, but in some countries where direct connection is not permitted, the bonding should be achieved by suitable capacitance, selected according to national regulations.

Screening and Shielding

Selective screening and shielding of other cables and equipment in the surrounding area may alleviate problems of interference. Screening of the entire welding installation may be considered for special applications.

¹ Portions of the preceding text are contained in EN 60974-10: "Electromagnetic Compatibility (EMC) product standard for arc welding equipment."

TABLE OF CONTENTS

Page

Definition of Welding Modes, Graphic Symbols.....	8,9
Product Summary, Recommended Process, Process and Equipment Limitations.....	10
Common Equipment Packages and Recommended Equipment	10

InstallationSection A

Specifications	A-1
Safety Precautions.....	A-2
Location and Mounting	A-2
Stacking	A-2
Lifting.....	A-2
Environmental Limitations.....	A-2
Electromagnetic Compatibility.....	A-2
Clearance Requirements.....	A-3
Input Voltage Selection and Ground Connections.....	A-4
Connection Diagram	A-4
System Connection.....	A-5
Connection Diagrams and Check List	A-6 thru A-16
Electrode and Work Connection	A-17
Cable Inductance, Remote Sense Lead Connection	A-18, A-19
Multi-Arc Circumferential Welds	A-20
Control Cable Connections, Common Equipment Connections.....	A-21

Operation Section B

Safety Precautions	B-1
Case Front Control Descriptions	B-2
Input Power Section	B-2
Case Back Components.....	B-3, B-4
Power-Up Sequence	B-5
Duty Cycle	B-5
Common Welding Procedures	B-5
Overview of the AC/DC Submerged Arc Process.....	B-5
Multiple Arc System Considerations	B-6
Basic Modes of Operation (CC / CV).....	B-6
Weld Sequence, Start Options, End Options, Re-Strike Timer	B-7
Weld Process Adjustment, Wave Balance, DC Offset, Frequency	B-8
Phase Adjustment for Multiple Arc Systems	B-9

AccessoriesSection C

Kits, Options and Accessories	C-1
Software Tools.....	C-1

Maintenance.....Section D

Safety Precautions.....	D-1
Routine and Periodic Maintenance	D-1
Calibration Specification	D-1

Troubleshooting.....Section E

How to Use Troubleshooting Guide	E-1
Using the Status LED to Troubleshoot System Problem.....	E-2
Error Codes	E-3, E-4
Troubleshooting Guide	E-5

Wiring Diagrams and Dimension PrintSection F

Wiring Diagram - Power Wave® AC/DC 1000® SD	F-1
Wiring Diagram - AC Switch	F-2
Dimension Print	F-3

Parts List.....parts.lincolnelectric.com

Content/details may be changed or updated without notice. For most current Instruction Manuals, go to parts.lincolnelectric.com.

DEFINITIONS OF WELDING MODES

NON-SYNERGIC WELDING MODES

- A Non-synergic welding mode requires all welding process variables to be set by the operator.

SYNERGIC WELDING MODES

- A Synergic welding mode offers the simplicity of single knob control. The machine will select the correct voltage and amperage based on the wire feed speed (WFS) set by the operator.

COMMON WELDING ABBREVIATIONS

SAW

- Submerged Arc Welding

GRAPHIC SYMBOLS THAT APPEAR ON THIS MACHINE OR IN THIS MANUAL



WORK SENSE LEAD CONNECTOR



MULTI-ARC CONNECTOR



PARALLEL ARC CONNECTOR

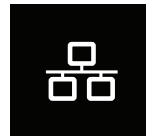

ETHERNET CONNECTOR



ARC LINK CONNECTOR



















DEVICENET CONNECTOR



115VAC RECEPTACLE

GRAPHIC SYMBOLS THAT APPEAR ON THIS MACHINE OR IN THIS MANUAL

	INPUT POWER		
	ON	U_0	OPEN CIRCUIT VOLTAGE
	OFF	U_1	INPUT VOLTAGE
	HIGH TEMPERATURE	U_2	OUTPUT VOLTAGE
	MACHINE STATUS	I_1	INPUT CURRENT
	CIRCUIT BREAKER	I_2	OUTPUT CURRENT
	WIRE FEEDER		PROTECTIVE GROUND
	POSITIVE OUTPUT		
	NEGATIVE OUTPUT		WARNING or CAUTION
	3 PHASE INVERTER		Explosion
	INPUT POWER		Dangerous Voltage
$3 \sim$	THREE PHASE		Shock Hazard
	DIRECT CURRENT		

PRODUCT SUMMARY

The Power Wave® AC/DC 1000® SD is a high performance, digitally controlled inverter welding power source. It is capable of producing a variable frequency and amplitude AC output, DC positive output, or DC negative output without the need for external reconnection. It utilizes complex, high-speed waveform control to support a variety of constant current and constant voltage welding modes in each of its output configurations.

The Power Wave® AC/DC 1000® SD power source is designed to be a part of a modular welding system. Each welding arc may be driven by a single machine, or by a number of machines in parallel. In multiple arc applications the phase angle and frequency of different machines can be synchronized by interconnecting the units with a control cable to improve performance and reduce the effects of arc blow.

The Power Wave® AC/DC 1000® SD is primarily designed to interface with compatible ArcLink equipment. However, it can also communicate with other industrial machines and monitoring equipment via DeviceNet, or Ethernet. The result is a highly integrated and flexible welding cell.

RECOMMENDED PROCESSES

The Power Wave® AC/DC 1000® SD is designed for submerged arc welding (SAW). Due to its modular design the Power Wave® AC/DC 1000® SD can operate on either single arc or in multi-arc applications with up to six arcs. Each machine is factory preprogrammed with multiple welding procedures to support all types of submerged arc welding. The Power Wave® AC/DC 1000® SD carries an output rating of 1000 amps, 44 volts (at 100% duty cycle). If higher currents are required machines can be easily paralleled for up to 3000 amps on each arc.

PROCESS LIMITATIONS

The Power Wave® AC/DC 1000® SD is suitable only for the Submerged Arc Process (SAW).

EQUIPMENT LIMITATIONS

The Power Wave® AC/DC 1000® SD can be used in outdoor environments. The Operating Temperature Range is 14°F to 104°F (-10°C to +40°C).

Only the MAXsa™ 22 or MAXsa™ 29 Wire Drives and MAXsa™ 10 or MAXsa™ 19 Controllers may be used with a Power Wave® AC/DC 1000® SD in a Multi Arc system. Other Lincoln or non-Lincoln Wire Drives can only be used with custom interfaces.

The Power Wave® AC/DC 1000® SD will support a maximum average output current of 1000 Amps at 100% Duty Cycle.

COMMON EQUIPMENT PACKAGES

BASIC PACKAGE

K2803-x Power Wave® AC/DC 1000® SD

K2370-x MAXsa™ 22 Wire Drive

K2814-x MAXsa™ 10 Controller / User Interface

K2683-xx Control Cable (5 pin – 5 pin) - power source to controller.

K1785-xx Control Cable (14 pin – 14 pin) - Controller to Wire Drive.

OPTIONAL KITS

K1785-xx Control Cable (14 pin – 14 pin) - for paralleling / multiple arc applications.

K2312-x MAXsa™ 29 Wire Drive (for fixture builders).

K2311-1 Motor Conversion Kit (to convert existing NA-3/NA-4/NA-5 wire feeder gear boxes).

K2444-1 CE, C-Tick Filter Kit

K2626-x MAXsa™ 19 Controller (for fixture builders that do not require the MAXsa™ 10 Controller).

RECOMMENDED EQUIPMENT

(See Installation Section)

TECHNICAL SPECIFICATIONS - Power Wave® AC/DC 1000® SD (K2803-2*)

INPUT AT RATED OUTPUT - THREE PHASE ONLY		
INPUT VOLTS 3 PHASE 50/60 Hz	INPUT CURRENT AMPS	OUTPUT CONDITIONS
380	82	1000A@44V. 100% Duty Cycle
400	79	
460	69	
500	62	
575	55	
IDLE POWER WATTS	POWER FACTOR @ RATED OUTPUT	EFFICIENCY @ RATED OUTPUT
225	.95	86%

WELDING PROCESSES	
Process	Electrode Diameter Range
SAW	5/64 – 7/32" (2 – 5.6 mm)
Output Range (Amperes)	Wire Feed Speed Range
100 - 1000	See Wire Drive Manual

OUTPUT	
OPEN CIRCUIT VOLTAGE	AUXILIARY POWER (CIRCUIT BREAKER PROTECTED)
77V	40 VDC AT 10 AMPS 115 VAC AT 10 AMPS
PROCESS CURRENT RANGES (AC or DC)	
SAW-DC+ SAW-DC- SAW-AC	} 100 amps @24 Volts 1000 Amps @44 Volts (Actual range may be limited by process)

PHYSICAL DIMENSIONS			
HEIGHT	WIDTH	DEPTH	WEIGHT
49.13 in 1248 mm	19.71 in 501mm	46.60 in 1184 mm	800 lbs. 363 kg.

RECOMMENDED INPUT WIRE AND FUSE SIZES ¹			
3 PHASE INPUT VOLTAGE 50/60Hz	TYPE 90°C COPPER WIRE ³ IN CONDUIT AWG (mm ²)	COPPER GROUNDING CONDUCTOR AWG (mm ²)	TIME-DELAY FUSE OR BREAKER ² AMPS
380	3(25)	8 (10)	100
400	3(25)	8 (10)	90
460	4(25)	8 (10)	90
500	4(25)	8 (10)	80
575	6(16)	10 (6)	70

TEMPERATURE RANGES	
OPERATING TEMPERATURE RANGE	STORAGE TEMPERATURE RANGE
14°F to 104°F(-10°C to 40°C)	-40°F to 185°F(-40°C to 85°C)

¹ Wire and Fuse Sizes based upon the U.S. National Electric Code and maximum output for 40°C (104°) ambient.
² Also called "inverse time" or "thermal/magnetic" circuit breakers; circuit breakers that have a delay in tripping action that decreases as the magnitude of current increases.
³ Fail to use proper type of copper wire will cause fire hazards.
 * An external filter will be required to meet CE and C-Tick conducted emission requirements. It will meet CE and C-Tick requirements with the use of an optional external filter. (K2444-3 CE and C-Tick Filter Kit)

Insulation Class: Class F(155°C)

IP 23  EN 60974-1

SAFETY PRECAUTIONS

Read this entire installation section before you start installation.



WARNING



ELECTRIC SHOCK can kill.

- Only qualified personnel should perform this installation.
- Turn the input power OFF at the disconnect switch or fuse box before working on this equipment. Turn off the input power to any other equipment connected to the welding system at the disconnect switch or fuse box before working on the equipment.
- Do not touch electrically hot parts.
- Always connect the Power Wave grounding lug (located inside the reconnect input access door) to a proper safety (Earth) ground.

LOCATION AND MOUNTING

Place the welder where clean cooling air can freely circulate in through the rear louvers and out through the case sides and front. Dirt, dust, or any foreign material that can be drawn into the welder should be kept at a minimum. Failure to observe these precautions can result in excessive operating temperatures and nuisance shutdowns. See the Clearance Requirements and **Figure A.1** in this section.

This equipment is for industrial use only and it is not intended for use in residential locations where the electrical power is provided by the public low-voltage supply system. There can be potential difficulties in residential locations due to conducted as well as radiated radio-frequency disturbances. The EMC or RF classification of this equipment is Class A.

STACKING



CAUTION

DO NOT MOUNT OVER COMBUSTIBLE SURFACES.

Where there is a combustible surface directly under stationary or fixed electrical equipment, the surface shall be covered with a steel plate at least .06" (1.6mm) thick, which shall extend not more than 5.90" (150mm) beyond the equipment on all sides.

Power Wave® AC/DC 1000® SD machine cannot be stacked.

LIFTING



WARNING



FALLING EQUIPMENT can cause injury.

- Lift only with equipment of adequate lifting capacity.
- Be sure machine is stable when lifting.
- Do not lift this machine using lift bail if it is equipped with a heavy accessory such as trailer or gas cylinder.
- Do not lift machine if lift bail is damaged.
- Do not operate machine while suspended from lift bail.

Lift the machine by the lift bail only. The lift bail is designed to lift the power source only. Do not attempt to lift the Power Wave® AC/DC 1000® SD with accessories attached to it.

ENVIRONMENTAL LIMITATIONS

The Power Wave® AC/DC 1000® SD can be used in an outdoor environment with an IP 23 rating. It should not be subjected to falling water, nor should any parts of it be submerged in water. Doing so may cause improper operation as well as pose a safety hazard. The best practice is to keep the machine in a dry, sheltered area.

ELECTROMAGNETIC COMPATIBILITY (EMC)

The EMC classification of the Power Wave® AC/DC 1000® SD is Industrial, Scientific and Medical (ISM) group 2, class A. The Power Wave® AC/DC 1000® SD is for industrial use only.

Locate the Power Wave® away from radio controlled machinery.



CAUTION

The normal operation of the Power Wave® AC/DC 1000® SD may adversely affect the operation of RF controlled equipment, which may result in bodily injury or damage to the equipment.

CLEARANCE REQUIREMENTS

The maintenance requirements of the Power Wave® AC/DC 1000® SD demand that enough clearance behind the machine be maintained. This is especially important where more than one machine is to be used or if the machines are going to be rack mounted.

The rear portion of the machine that contains the filter and the cooling fans slides out for easy access to clean the heat sink fins.

Removing the four(4) clips and pulling back on the rear portion of the machine will provide access for cleaning the machine and checking the filter. The filter is removed from the right side of the machine.

Where machines are mounted side by side, the machine that is furthest to the right will need to have the indicated clearance to the right side for filter removal. See Figure A.1.

FIGURE A.1 - CLEARANCE REQUIREMENTS

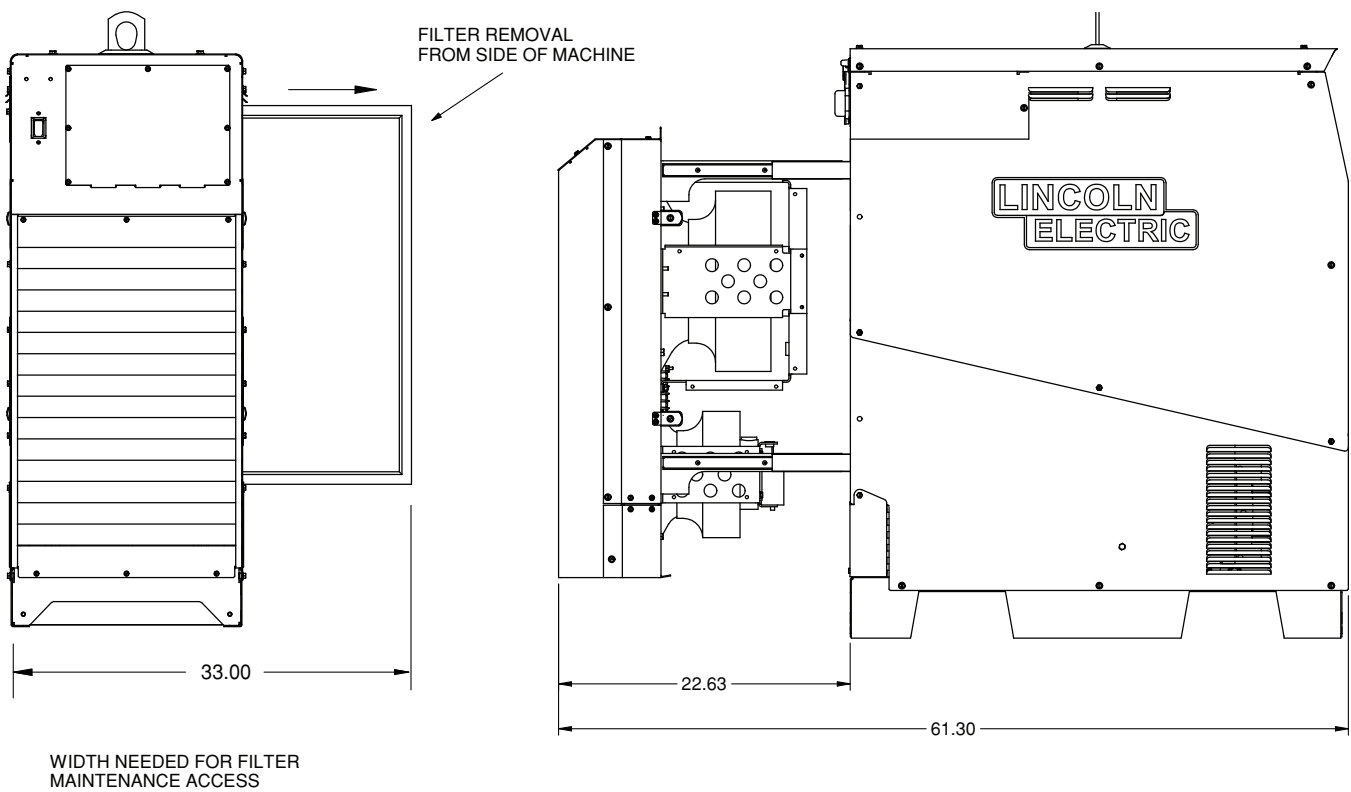

INPUT AND GROUND CONNECTIONS

MACHINE GROUNDING



The frame of the welder must be grounded. A ground terminal marked with the symbol shown is located inside the reconnect / input access door for this purpose. See your local and national electrical codes for proper grounding methods.

INPUT CONNECTION



ELECTRIC SHOCK can kill.



- **Only a qualified electrician should connect the input leads to the Power Wave®. Connections should be made in accordance with all local and National Electrical Codes and the connection diagram located on the inside of the reconnect / input access door of the machine. Failure to do so may result in bodily injury or death.**

Use a three-phase supply line. A 1.75 inch (45 mm) diameter access hole for the input supply is located on the case back. Connect L1, L2, L3 and ground according to the Input Supply Connection Diagram.

INPUT FUSE AND SUPPLY WIRE CONSIDERATIONS

Refer to Specifications page for recommended fuse and wire sizes. Fuse the input circuit with the recommended super lag fuse or delay type breakers (also called "inverse time" or "thermal/magnetic" circuit breakers). Choose input and grounding wire size according to local or national electrical codes. Using fuses or circuit breakers smaller than recommended may result in "nuisance" shut-offs from welder inrush currents, even if the machine is not being used at high currents.

INPUT VOLTAGE SELECTION

Welders are shipped connected for the highest input voltage listed on the rating plate. To move this connection to a different input voltage, see the diagram located on the inside of the input access door, or the diagram shown below (Figure A.2). If the Auxiliary lead (indicated as 'A') is placed in the wrong position, there are two possible results.

- If the lead is placed in a position higher than the applied line voltage, the welder may not come on at all.
- If the Auxiliary lead is placed in a position lower than the applied line voltage, the welder may not come on, and fuse in the reconnect area may open. If this occurs, turn off the input voltage, properly connect the auxiliary lead, replace the fuse, and try again.

FIGURE A.2 - INPUT SUPPLY CONNECTION FOR POWER WAVE® AC/DC 1000® SD

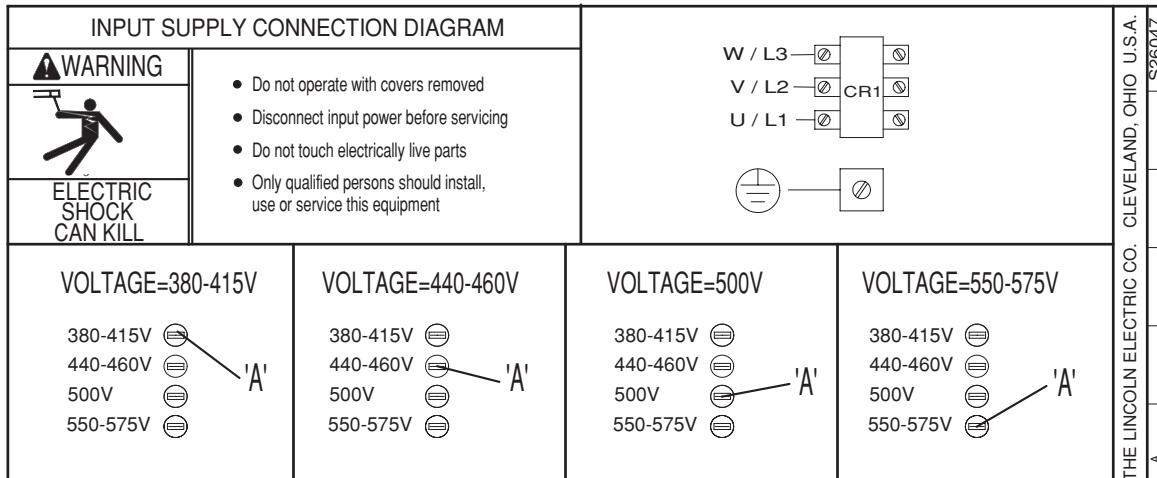

SYSTEM CONNECTION

System Overview

The Power Wave® AC/DC 1000® SD power source is designed to be a part of a modular welding system typically controlled by a MAXsa™ 10 Controller or a customer supplied Programmable Logic Controller (PLC). Each welding arc may be driven by a single power source or by a number of power sources connected in parallel. The actual number of power sources per arc will vary depending on the application. When only one power source is required for an arc group, it must be configured as a Master. When parallel machines are required, one is designated as the Master and the rest as Slaves. The synchronizing connectors for paralleled machines are on the back of the power source. The Master controls the AC switching for the arc group, and the Slaves respond accordingly. See Figure A.3.

When employed in a multi-arc AC system the arcs must be synchronized to each other. The Master for each arc can be configured to follow a dedicated external synchronization signal to determine its frequency and balance. The Synchronizing Connectors on the back of the Power Wave® AC/DC 1000® SD provide the means to synchronize the AC wave shapes of up to six different arcs to a common carrier frequency. (See Figure A.3). This frequency can range from 20 hertz to 100 hertz. It can also control the phase angle between arcs to reduce the effects of welding related issues such as "Arc Blow".

FIGURE A.3 - SYNCHRONIZING CONNECTORS

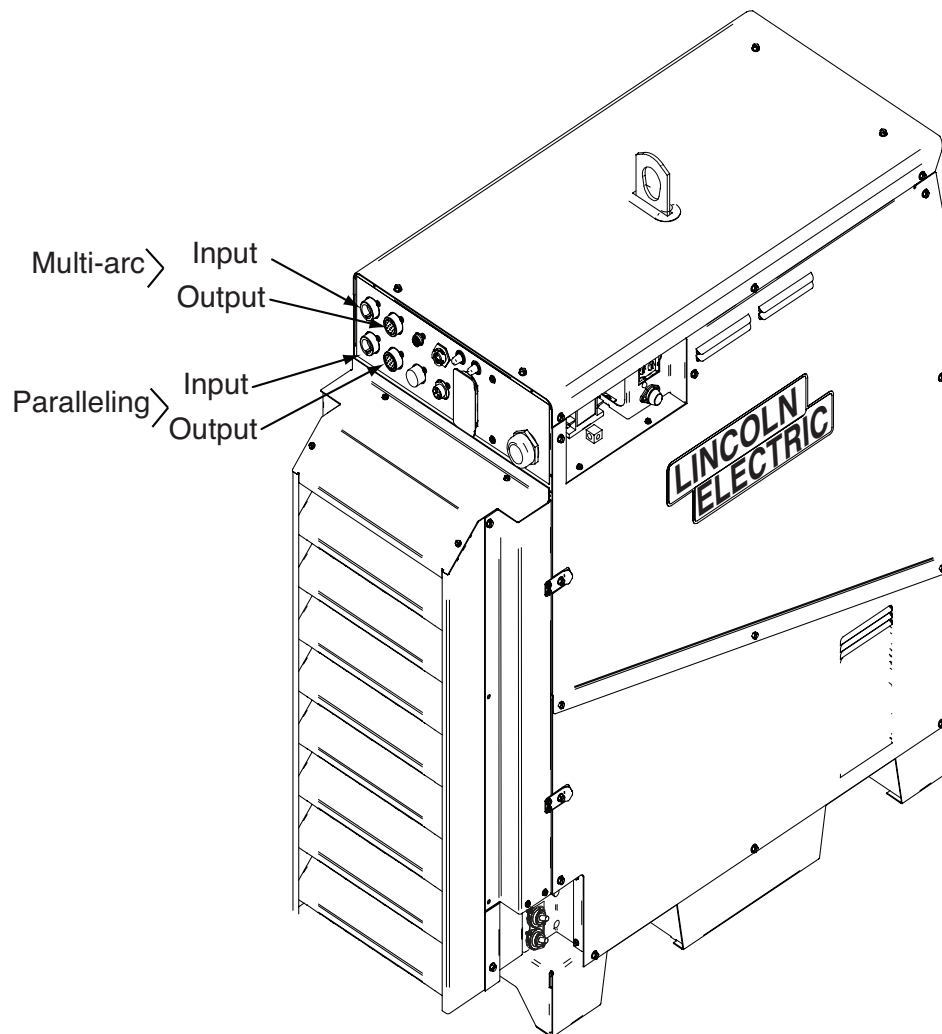

The arc to arc phase relationship is determined by the timing of each arc's "sync" signal relative to the "sync" signal of ARC 1. DIP Switches on the in each machine must be set to identify it as a Master Lead, Master Trail or Slave. See Figure A.4

In a typical multi-arc system, each arc is controlled by its own MAXsa™ 10 Controller. The basic characteristics of the individual arcs such as WFS, amplitude, and offset are set locally by each arc's dedicated controller. The frequency, balance, and phase shift parameters of each arc are controlled by the MAXsa™ 10 Controller for ARC 1 (Master Lead).

NOTE: The Power Wave® AC/DC 1000® SD is backwards compatible with the K2344-2 Power Wave® AC/DC 1000 in tandem or multi-arc systems. The Power Wave® AC/DC 1000® SD and K2344-2 machines cannot be connected in parallel. Paralleled machines must be of the same type. A K1805-1 (14 to 22 pin adapter cable) is required to interface to the K2282-1 Systems Interface in these setups A PLC interface is an alternate method of control for larger systems. The PLC is typically connected via DeviceNet directly to the Master power source of each arc group in the system. MAXsa™ 19 Controller is still required to power the Wire Drive. Contact your Local Lincoln Electric Representative for more information.

The connection diagrams describe the layout of several typical systems including Multi-Arc and Paralleled machine set-ups. Each system also has a step by step "Installation Checklist".

FIGURE A.4 - DIP SWITCH SETTINGS

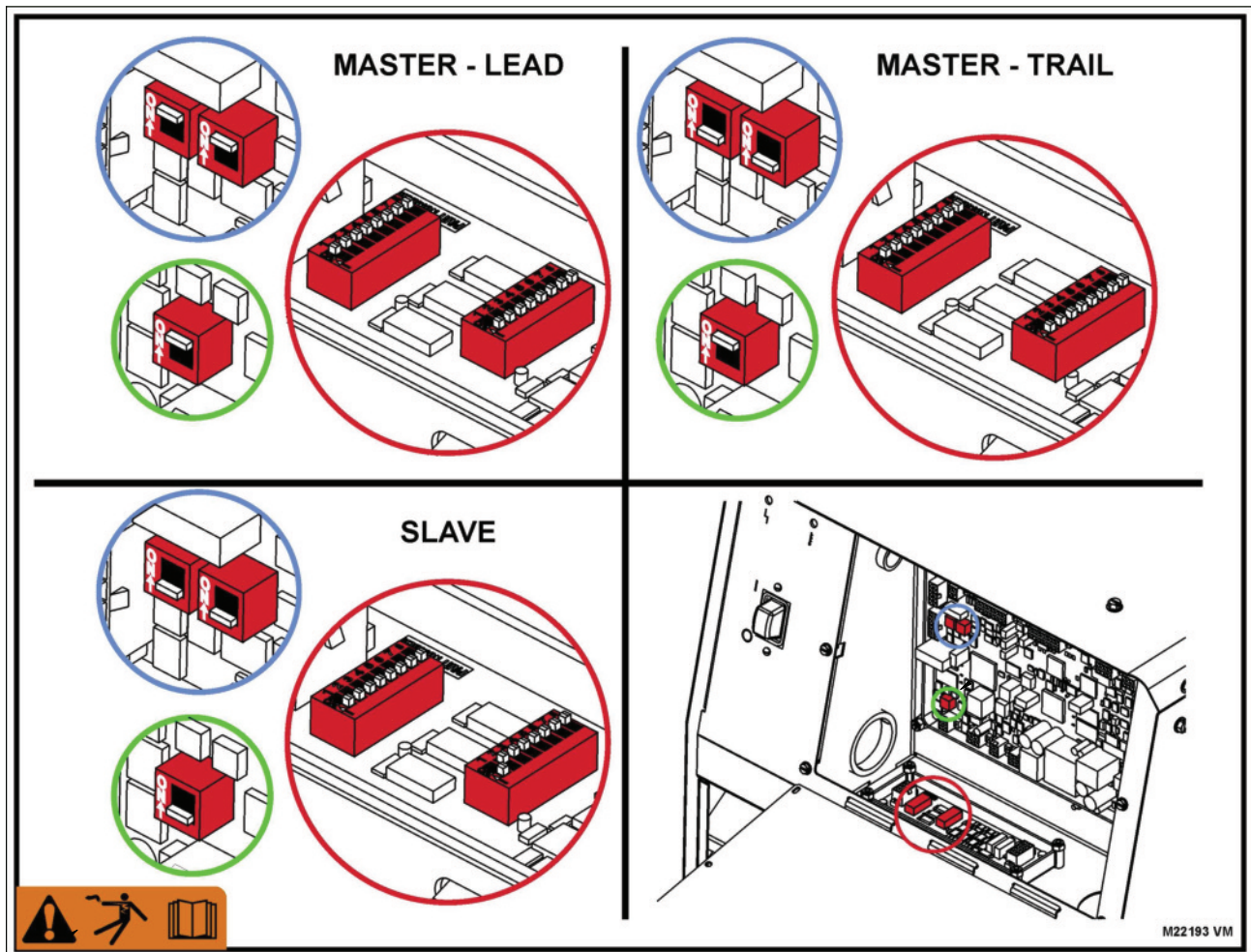
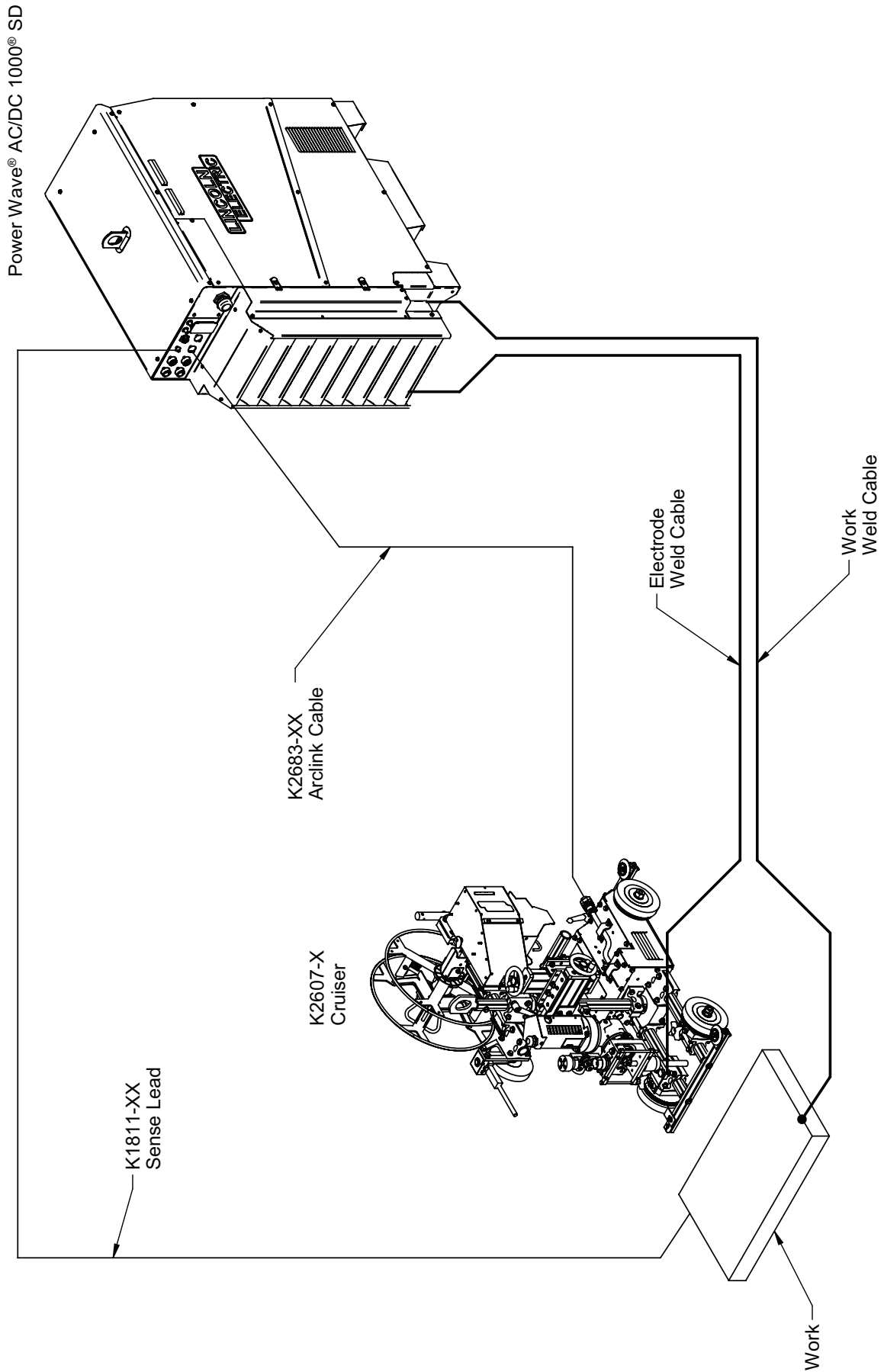

FIGURE A.5 - CRUISER CONNECTION DIAGRAM



CRUISER™ SYSTEM CHECKLIST (See Figure A.5)

- Place the Power Wave® AC/DC 1000® SD in a suitable operating location.
- Place the Cruiser™ Tractor in its operating location.
- Connect K2683-xx Heavy Duty ArLink Control Cable (5 pin) between Power Wave® AC/DC 1000® SD and the Cruiser™ Tractor

- Install Work Voltage Sense Lead (21) from the Power Wave® AC/DC 1000® SD per recommended guidelines.
- Connect / Install welding cables per recommended "Output Cable Guidelines" (**Table A.1**).
- Open the Power Wave® AC/DC 1000® SD front panel and check the DIP switch settings per the decal on the panel. Factory Setting is "Master-Lead". (See **Figure A.4**).

- Connect input power to Power Wave® AC/DC 1000® SD per recommended guidelines.
- Confirm that latest software is updated in all equipment prior to installation (www.powerwavesoftware.com)
- Turn on Power Wave® AC/DC 1000® SD, and verify all system Status Lights are solid green.
- Select a Welding process and configure starting and ending options.

FIGURE A.6 - SINGLE ARC CONNECTION DIAGRAM

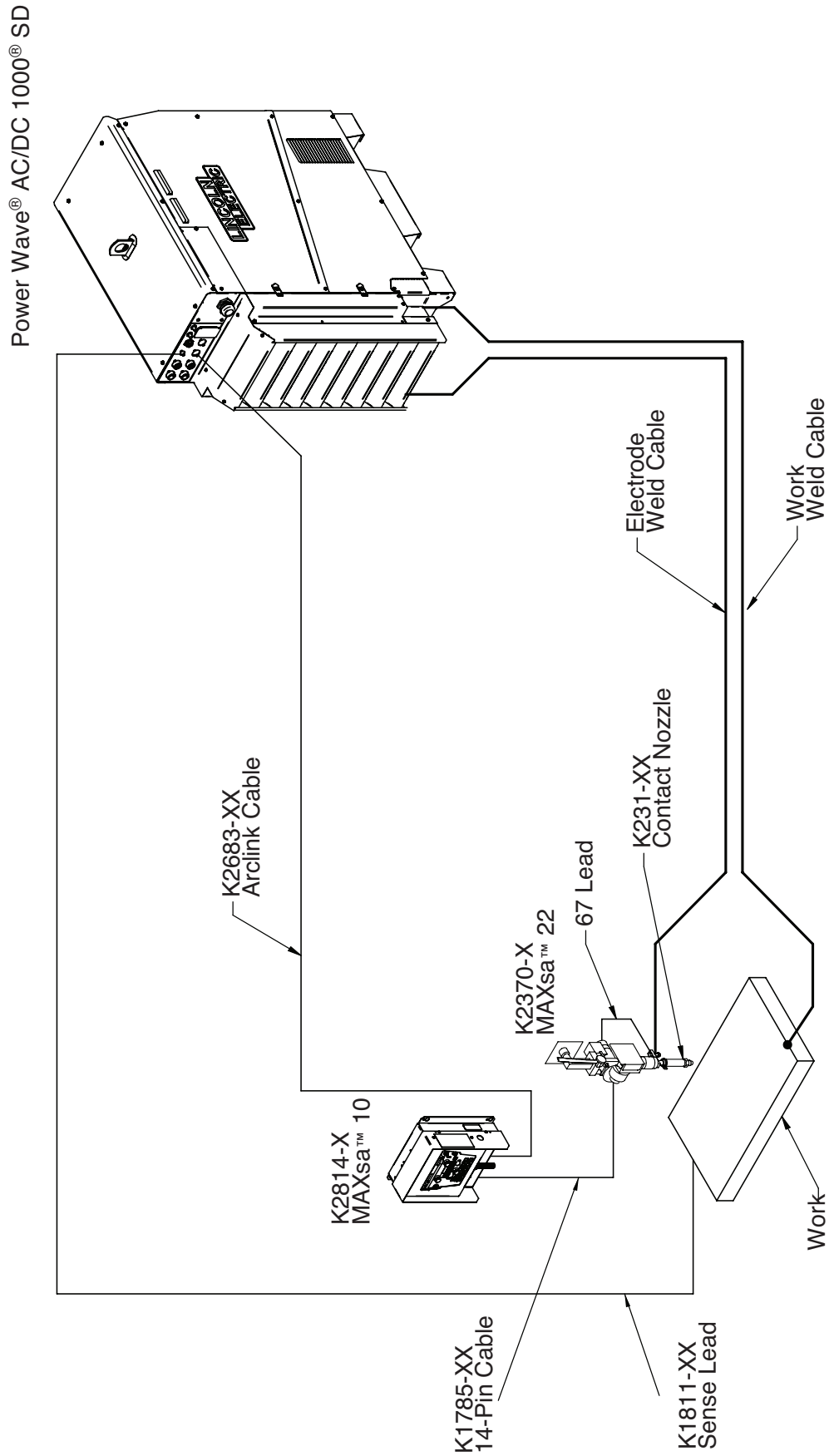

SINGLE ARC SYSTEM CHECKLIST (See Figure A.6)

- Place the Power Wave® AC/DC 1000® SD in a suitable operating location.
- Mount MAXsa™ 10 Controller.
- Install MAXsa™ 22 Wire Drive and other accessories in their operating location.
- Connect K2683-xx Heavy Duty ArcLink Control Cable (5 pin) between Power Wave and MAXsa™ 10.
- Connect K1785-xx Wire Feeder Control Cable (14 pin) between the MAXsa™ 10 and the MAXsa™ 22.
- Install Electrode Sense Lead (67) at the feeder and the Work Sense Lead (21) from the Power Wave® AC/DC 1000® SD per recommended guidelines.
- Connect / Install welding cables per recommended "Output Cable Guidelines" (**Table A.1**).
- Open the Power Wave® AC/DC 1000® SD front panels and check the DIP switch settings per the decal on the panel. Factory Setting is "Master-Lead". (See **Figure A.4**).
- Connect input power to Power Wave® AC/DC 1000® SD per recommended guidelines.
- Turn on Power Wave® AC/DC 1000® SD, and verify all system Status Lights are solid green.
- Confirm that latest software is updated in all equipment prior to installation (www.powerwavesoftware.com)
- Select a Welding process and configure starting and ending options.

FIGURE A.7 - TANDEM ARC CONNECTION DIAGRAM

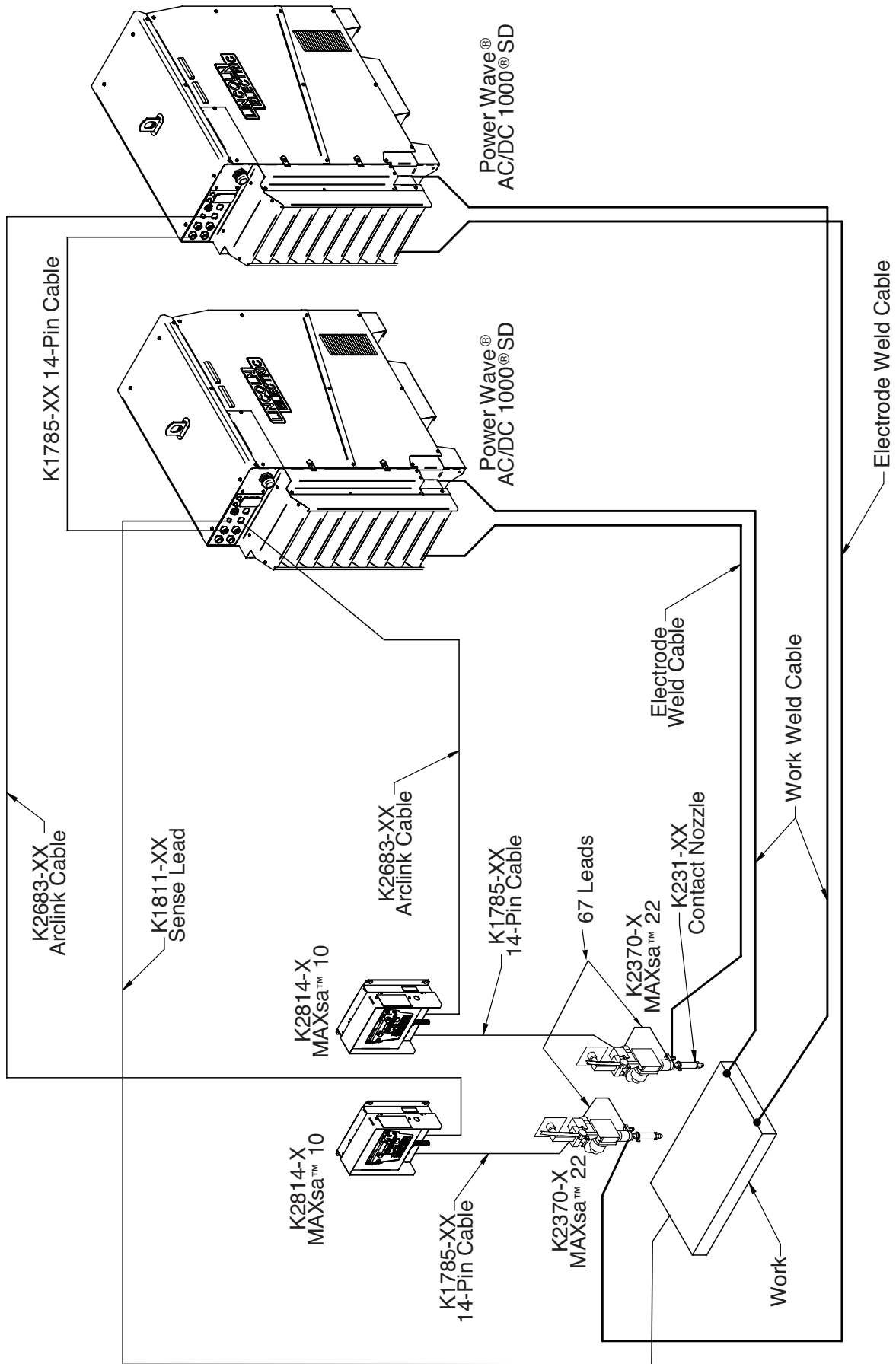

TANDEM ARC (2-ARC) SYSTEM CHECKLIST (See Figure A-7)

- Place the Power Wave® AC/DC 1000® SD units in a suitable operating location.
- Mount MAXsa™ 10 Controllers.
- Install MAXsa™ 22 Wire Drives and other accessories in their operating location.
- Connect a K1785-xx Wire Feeder Control Cable (14 pin) between the two power sources (top connectors).
- Connect K2683-xx Heavy Duty ArcLink Control Cables (5 pin) between Power Wave units and MAXsa™ 10 controllers.
- Connect K1785-xx Wire Feeder Control Cable (14 pin) between the MAXsa™ 10 controllers and the MAXsa™ 22 feeders.
- Install Electrode Sense Lead (67) at each feeder and the Work Sense Lead (21) from the Lead Power Wave® AC/DC 1000® SD Master per guidelines.
- Connect / Install welding cables per recommended "Output Cable Guidelines" (**Table A.1**).
- Open the Power Wave® AC/DC 1000® SD front panels and configure DIP switch settings per the decal on the panel. (See **Figure A.4**).
- Connect input power to Power Wave® AC/DC 1000® SD units per recommended guidelines.
- Turn on Power Wave® AC/DC 1000® SD and verify all system Status Lights are solid green.
- Confirm that latest software is updated in all equipment prior to installation (www.powerwavesoftware.com)
- Run the subarc cell configurator from PC Tools (See **Section C** of this manual or go to www.powerwavesoftware.com).
- Select a Welding process and configure starting and ending options.

FIGURE A.8 - PARALLELING CONNECTION DIAGRAM

Connection Diagram - Parallel Machines

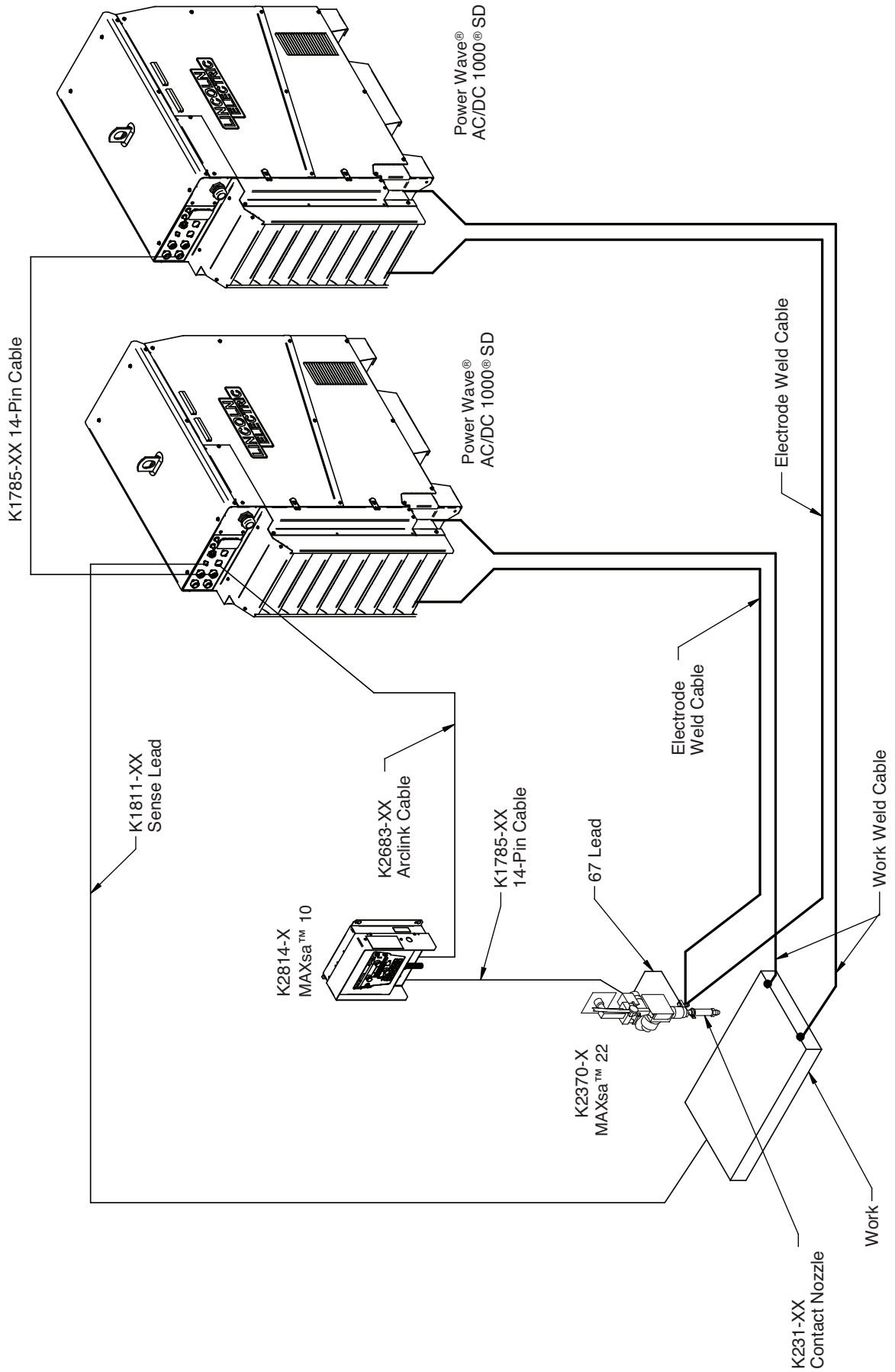

PARALLEL CONNECTION CHECKLIST (See Figure A.8)

- Place the Power Wave® AC/DC 1000® SD units in a suitable operating location.
- Mount MAXsa™ 10 Controller.
- Install MAXsa™ 22 Wire Drive and other accessories in their operating location.
- The MAXsa™ Controller must be connected to the Master Power Source. Connect K2683-xx Heavy Duty ArcLink Control Cable (5 pin) between Power Wave and MAXsa™ 10 controller.
- Connect K1785-xx Wire Feeder Control Cable (14 pin) between the MAXsa™ 10 controller and the MAXsa™ 22 feeder.

- Connect a K1785-xx Wire Feeder Control Cable (14 pin) between the two power sources (top connectors).
- Install Electrode Sense Lead (67) at the feeder and the Work Sense Lead (21) from the Lead Power Wave® AC/DC 1000® SD Master per guidelines.
- Connect / Install welding cables to both the “master” and “slave” machine per recommended “Output Cable Guidelines” (**Table A.1**).
- Open the Power Wave® AC/DC 1000® SD front panels and configure DIP switch settings per the decal on the panel. (See **Figure A.4**).
- Connect input power to Power Wave® AC/DC 1000® SD units per recommended guidelines.
- Turn on Power Wave® AC/DC 1000® SD, and verify all system Status Lights are solid green.
- Confirm that latest software is updated in all equipment prior to installation (www.powerwavesoftware.com)
- For tandem setups, run the subarc cell configurator from PC Tools (See **Section C** of this manual or go to www.powerwavesoftware.com).
- Select a Welding process and configure starting and ending options.

FIGURE A.9 - MAXsa™ 19 CONNECTION DIAGRAM

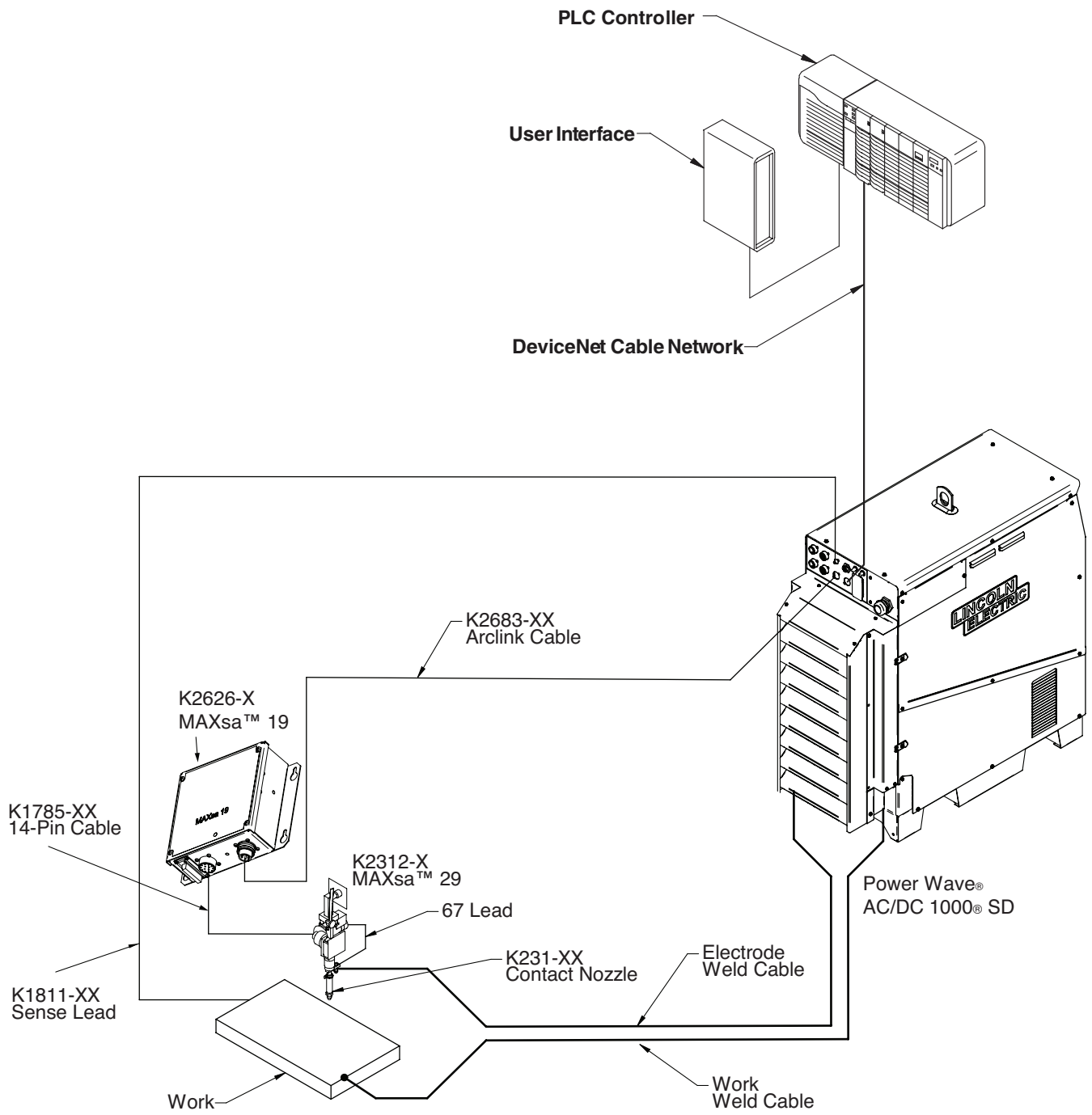

MAXsa™ 19 SYSTEM CHECKLIST (See Figure A.9)

- Place the Power Wave® AC/DC 1000® SD in a suitable operating location.
- DeviceNet PLC controlled systems: Mount DeviceNet PLC controller and User Interface.
- Mount MAXsa™ 19 in it's operating location.
- Connect K2683-xx Heavy Duty ArcLink Control Cables (5 pin) between Power Wave® AC/DC 1000® SD and MAXsa™ 19.

- Connect K1785-xx Wire Feeder Control Cable (14 pin) between the MAXsa™ 19 and the MAXsa™ 29.
- DeviceNet PLC controlled systems: Connect each Arc Master power source to the PLC via the DeviceNet network.

- Install Work Voltage Sense Lead (21) from Power Wave® AC/DC 1000® SD per recommended guidelines.
- Connect / Install welding cables per recommended "Output Cable Guidelines" (**Table A.1**).
- Open the Power Wave® AC/DC 1000® SD front panels and configure DIP switch settings per the decal on the panel. Factory setting is "Master-Lead".(See **Figure A.4**).
- Connect input power to Power Wave® AC/DC 1000® SD per recommended guidelines.
- Turn on Power Wave® AC/DC 1000® SD and verify all system Status Lights are solid green.
- DeviceNet PLC controlled systems: Run Weld Manager. For each Arc Master connect to the power source. Under Network Settings -> DeviceNet-> Configuration, configure the DeviceNet MAC address and baud rate.
- Run Weld Manager. For each Arc Master connect to the power source. Under Feeder Settings -> Wire Feeder, verify the appropriate Feeder and gear ratio are selected.
- Confirm that latest software is updated in all equipment prior to installation (www.powerwavesoftware.com)
- Select a Welding process and configure starting and ending options.

ELECTRODE AND WORK CONNECTIONS

General Guidelines

The unique switching structure of the Power Wave® AC/DC 1000® SD allows it to produce DC positive, DC negative or AC output waveforms without repositioning the work and electrode leads. Additionally, no DIP switch changes are required to switch between the different polarities. All of this is controlled internally by the Power Wave® AC/DC 1000 SD, and based exclusively on the weld mode selection.

The following recommendations apply to all output polarities and weld modes:

- **Select the appropriate size cables per the "Output Cable Guidelines" below.** Excessive voltage drops caused by undersized welding cables and poor connections often result in unsatisfactory welding performance. Always use the largest welding cables (electrode and work) that are practical, and be sure all connections are clean and tight.

Note: Excessive heat in the weld circuit indicates undersized cables and/or bad connections.

- **Route all cables directly to the work and wire feeder, avoid excessive lengths and do not coil excess cable.** Route the electrode and work cables in close proximity to one another to minimize the loop area and therefore the inductance of the weld circuit.
- **Always weld in a direction away from the work (ground) connection.**

TABLE A.1 - Output Cable Guidelines

Total Cable Length ft (m) Electrode and Work Combined	Duty Cycle	Number of Parallel Cables	Cable Size Copper
0 (0) to 250 (76.2)	80%	2	4/0 (120 mm ²)
0 (0) to 250 (76.2)	100%	3	3/0 (95 mm ²)

Electrode Connections

Connect cable(s) of sufficient size and length (Per Table A.1) to the "ELECTRODE" studs on the power source (located behind the cover plate on the lower right rear corner). Connect the other end of the electrode cable(s) to the tab of the contact nozzle. Be sure the connection to the nozzle makes tight metal-to-metal electrical contact.

Work Connections

Connect cable(s) of sufficient size and length (Per Table A.1) between the "WORK" studs (located behind the cover on the lower left rear corner) and the work piece. Be sure the connection to the work makes tight metal-to-metal electrical contact.

NOTE: For parallel and/or multiple arc applications with excessive ground path lengths, a common work connection bus should be used. The common work connection serves to minimize voltage drops associated with resistive losses in the ground paths. It should be made out of copper, and located as close as possible to the power sources (See Figure A.10).

FIGURE A.10

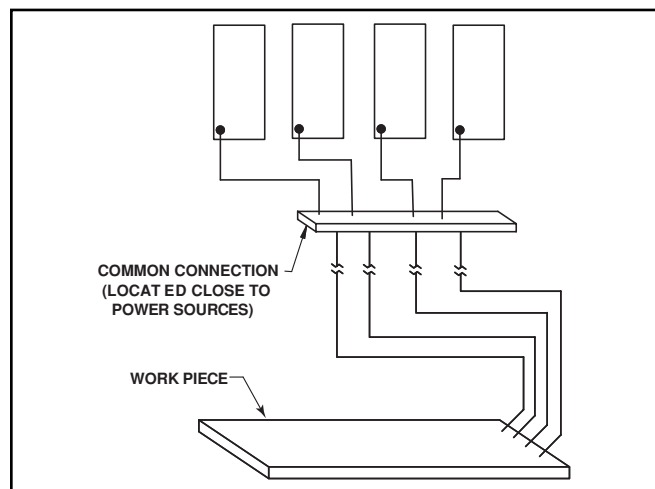

CABLE INDUCTANCE, AND ITS EFFECTS ON WELDING

Excessive cable inductance will cause the welding performance to degrade. There are several factors that contribute to the overall inductance of the cabling system including cable size, and loop area. The loop area is defined by the separation distance between the electrode and work cables, and the overall welding loop length. The welding loop length is defined as the total of length of the electrode cable (A) + work cable (B) + work path (C) (see Figure A.11). To minimize inductance always use the appropriate size cables, and whenever possible, run the electrode and work cables in close proximity to one another to minimize the loop area. Since the most significant factor in cable inductance is the welding loop length, avoid excessive lengths and **do not coil excess cable**. For long work piece lengths, a sliding ground should be considered to keep the total welding loop length as short as possible.

FIGURE A.11

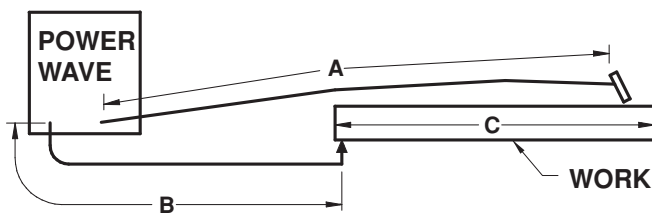

REMOTE SENSE LEAD CONNECTIONS

Voltage Sensing Overview

The best arc performance occurs when the Power Wave® AC/DC 1000® SD has accurate data about the arc conditions. Depending upon the process, inductance within the electrode and work cables can influence the voltage apparent at the studs of the welder, and have a dramatic effect on performance. To counteract this negative effect, remote voltage sense leads are used to improve the accuracy of the arc voltage information supplied to the control pc board.

There are several different sense lead configurations that can be used depending on the application. In extremely sensitive applications it may be necessary to route cables that contain the sense leads away from the electrode and work welding cables.



CAUTION

If the remote voltage sensing is enabled but the sense leads are missing, improperly connected extremely high welding outputs may occur.

Electrode Voltage Sensing

The remote ELECTRODE sense lead (67) is built into the wire feeder control cable (K1785) and accessible at the wire drive. It should always be connected to the Contact Assembly where the Weld Cable is connected. Enabling or disabling electrode voltage sensing is application specific, and automatically configured through software.

Work Voltage Sensing

The use of a remote work voltage sense lead is always required. The Power Wave® AC/DC 1000® SD is shipped from the factory with the remote work voltage sense lead enabled. It must be attached to the work as close to the weld as practical, but out of the weld current path. For more information regarding the placement of remote work voltage sense leads, see the section entitled "Voltage Sensing Considerations for Multiple Arc Systems." The remote WORK sense lead (21) can be accessed at the four-pin WORK sense lead connector located on the back panel of the Power Wave AC/DC 1000 SD.

NOTE: All of the machines of a given arc group (Master and Slaves) will relate to the Voltage Sense Lead of the Master machine.



CAUTION

Never connect the WORK sense lead at two different locations.



WARNING

ELECTRIC SHOCK can kill.



- Do not touch electrically live parts or electrodes with your skin or wet clothing.
- Insulate yourself from the work and ground.

- Always wear dry insulating gloves.

VOLTAGE SENSING CONSIDERATIONS FOR MULTIPLE ARC SYSTEMS

Special care must be taken when more than one arc is welding simultaneously on a single part. Remote sensing is required in Multi-arc applications

- **Avoid common current paths.** Current from adjacent arcs can induce voltage into each others current paths that can be misinterpreted by the power sources, and result in arc interference.
- **Position the sense leads out of the path of the weld current.** Especially any current paths common to adjacent arcs. Current from adjacent arcs can induce voltage into each others current paths that can be misinterpreted by the power sources, and result in arc interference.
- **For longitudinal applications,** connect all work leads at one end of the weldment, and all of the work voltage sense leads at the opposite end of the weldment. Perform welding in the direction away from the work leads and toward the sense leads. See Figure A.12.
- **For circumferential applications,** connect all work leads on one side of the weld joint, and all of the work voltage sense leads on the opposite side, such that they are out of the current path. See Figure A.13

FIGURE A.12 MULTI-ARC LONGITUDINAL WELDS

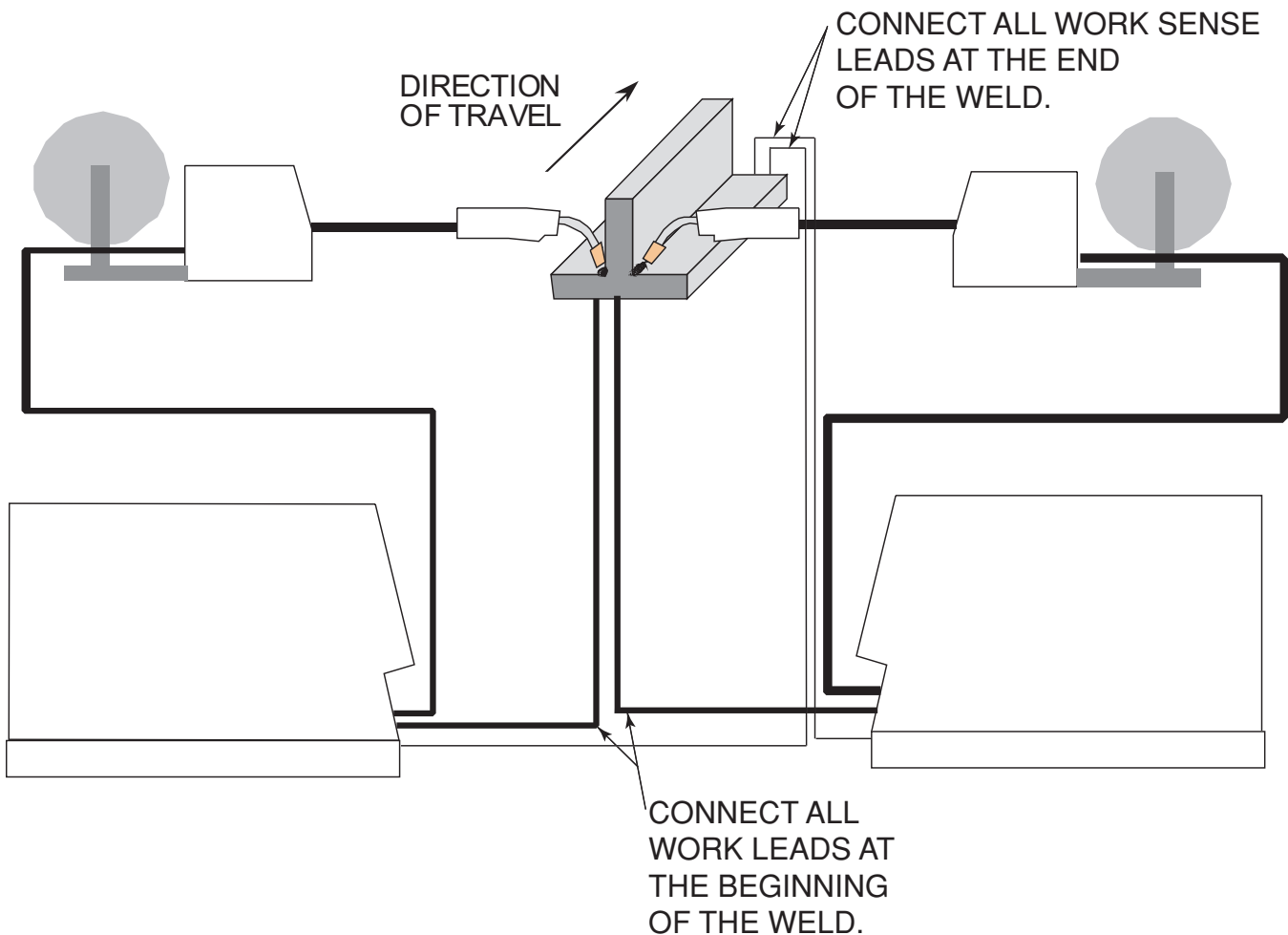
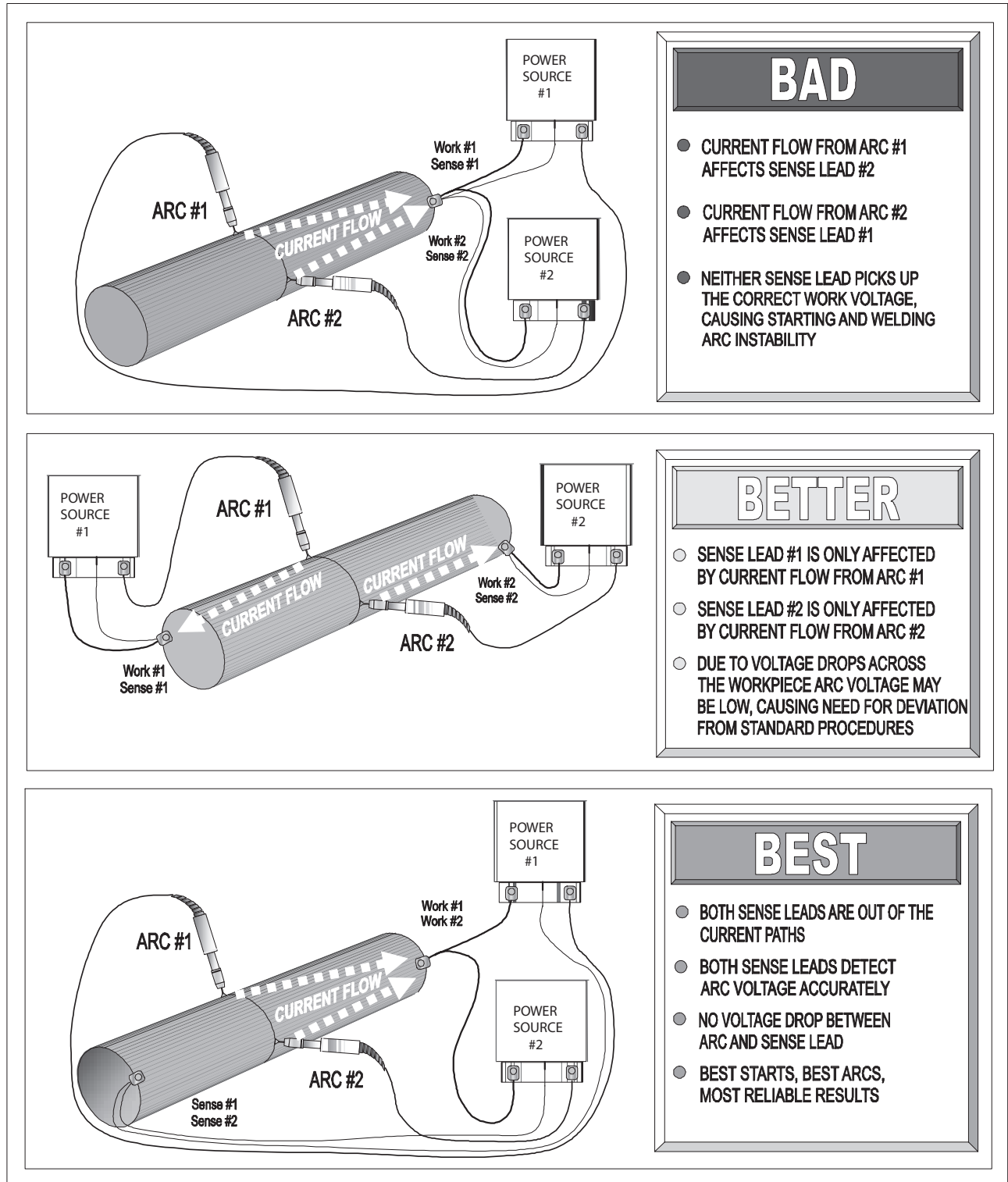

FIGURE A.13 MULTI-ARC CIRCUMFERENTIAL WELDS



CONTROL CABLE CONNECTIONS

GENERAL GUIDELINES

These guidelines apply to all communication cables including optional DeviceNet and Ethernet connections.

- **Genuine Lincoln control cables should be used at all times (except as noted otherwise).** Lincoln cables are specifically designed for the communication and power needs of the Power Wave®/ MAXsa™ systems. Most are designed to be connected end to end for ease of operation.
- **Always use the shortest cable lengths possible. DO NOT coil excess cable.** It is recommended that the total length of control cable does not exceed 100' (30.5M). The use of non-standard cables in excess of 25' (7.5M) can lead to communication problems (system shutdowns), poor motor acceleration (poor arc starting), and low wire driving force (wire feeding problems).
- **Best results will be obtained when the control cables are routed separate from the weld cables.** This minimizes the possibility of interference between the high currents flowing through the weld cables and the low level signals in the control cables.

COMMON EQUIPMENT CONNECTIONS

Connection Between MAXsa™ Controller and MAXsa™ series Wire Drive (K1785-xx)

The 14 pin Wire Drive Control Cable (K1785-xx) connects the Controller (MAXsa™ 10 or MAXsa™ 19) to the Wire Drive (MAXsa™ 22 or MAXsa™ 29). This cable should be kept as short as possible.

Connection Between Power Source and the MAXsa™ Controller (K2683-xx - ArcLink Control Cable).

Single and tandem arc systems are typically controlled by a MAXsa™ 10 Controller. In a tandem, or multi-arc system, each arc requires its own dedicated controller.

The 5-pin ArcLink control cable connects the power source to the MAXsa™ 10. If there is more than one power source per arc, it connects from the MAXsa™ 10 to the power source designated as the Master for that arc. The control cable consists of two power leads, one twisted pair for digital communication, and one lead for voltage sensing (67).

NOTE: Connections Between Power Source and Optional DeviceNet Programmable Logic Controller(PLC).

It is sometimes more practical and cost effective to use a custom PLC interface to control a multi-arc system (refer to the "DeviceNet Configuration" section for interface information). The Power Wave® AC/DC 1000® SD is equipped with a 5-pin DeviceNet mini style receptacle for this purpose. The receptacle is located on the rear panel of the machine See **Figure B.3** The DeviceNet cable is keyed and polarized to prevent improper connection.

NOTE: DeviceNet cables should not be routed with weld cables, wire drive control cables, or any other current carrying device that can create a fluctuating magnetic field.

In a typical system, a DeviceNet connection is made between the master power source of each arc, and the PLC interface. DeviceNet cables must be sourced locally by the customer. For additional guidelines refer to the "DeviceNet Cable Planning and Installation Manual" (Allen Bradley publication DN-6.7.2).

Connections Between Parallel Power Sources (K1785-xx - Control Cable).

To increase the output capacity for a given arc, the output studs of multiple Power Wave® AC/DC 1000® SD machines can be connected in parallel. The parallel machines utilize a master/slave control scheme to distribute the load evenly and to coordinate AC switching. K1785-xx cables connect the paralleled machines via the synchronizing connectors on the back of the machine. The system is currently limited to a maximum of 2 slaves per master, or a total of 3 machines per arc.

Connections Between Power Sources in Multi-Arc Applications (K1785-xx - Control Cable).

Synchronizing Connectors are available on the rear panel of the machine for Multi-Arc applications using the K1785-xx control cables. The system is currently limited to six(6) arcs, or a "Lead" and five "Trail" arcs.

SAFETY PRECAUTIONS

Read this entire section of operating instructions before operating the machine.



WARNING

ELECTRIC SHOCK can kill.



- Unless using cold feed feature, when feeding with gun trigger, the electrode and drive mechanism are always electrically energized and could remain energized several seconds after the welding ceases.
- Do not touch electrically live parts or electrodes with your skin or wet clothing.
- Insulate yourself from the work and ground.
- Always wear dry insulating gloves.



FUMES AND GASES can be dangerous.

- Keep your head out of fumes.
- Use ventilation or exhaust to remove fumes from breathing zone.



WELDING SPARKS can cause fire or explosion.

- Keep flammable material away.
- Do not weld on containers that have held combustibles.



ARC RAYS can burn.

- Wear eye, ear, and body protection.

Observe additional guidelines detailed in the beginning of this manual.

CASE FRONT CONTROLS

1. Power Switch: Controls input power to the Power Wave® AC/DC 1000® SD and any auxiliary equipment that may be connected to it.
2. Status Light: A two color LED that indicates system errors. Normal operation is steady green. Flashing green or red/green indicates a system error. See the **Troubleshooting Section**.

NOTE: The Power Wave® Status Light will flash green for up to 60 seconds at power up as the machine runs through a self test routine, and then go to steady green.

3. Thermal Light: A yellow light that comes ON when an over temperature situation occurs. The machine output is disabled until the machine cools down and the thermal light goes OFF.

NOTE: The Thermal Light may also indicate a problem with the AC Switch portion of the power source. See the **Troubleshooting Section**.

INPUT POWER SECTION

1. Input Contactor: Connection point for incoming 3 phase power. See the **Installation Section** for input wiring and fusing information.
2. Case Ground: Used to provide an “earth ground” for the frame of the welder. Consult your local and national electrical codes for proper grounding information.
3. Auxiliary Reconnect: Select the proper tap based on the supply voltage.
4. Fuse (F1): Protection for the primary side of the auxiliary transformer
5. Cord Connector: Input power cord strain relief.

FIGURE B.1 - CASE FRONT

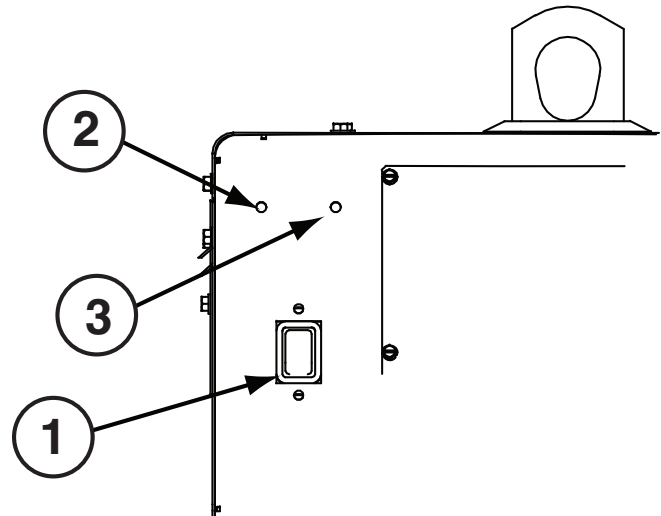
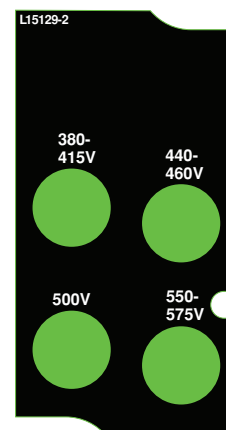
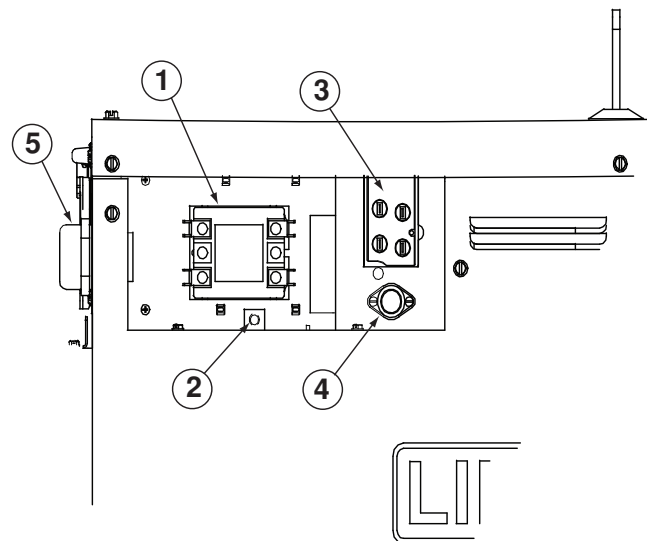

FIGURE B.2 - INPUT SECTION (LEFT SIDE)



CASE BACK COMPONENTS (See Figure B.3)

1. 10 Amp Circuit Breaker (CB1): Protects the 40VDC wire feeder power supply.
2. 10 amp Circuit Breaker (CB-2): Protects the 115VAC Auxiliary Power Receptacle.
3. Work Sense Lead Connector(4 Pin): Connection point for the #21 lead.
4. Arclink Connector (5 Pin): Provides power and communication to the controller.
5. Devicenet Connector: Provides Devicenet communication to remote equipment.
6. Output Studs (2) (WORK): Connection point for welding cable(s) to the work piece.
7. Output Studs (2) (ELECTRODE): Connection point for welding cables to the Wire Drive.
8. Auxiliary Output Receptacle: Provides 10 amps of 115VAC power.
9. Ethernet Connector (RJ-45): Provides Ethernet communication to remote equipment.
10. Master Input: From Lead or previous trail arc in a Multi-arc system
11. Master Output: To subsequent trail arc in a Multi-arc system.
12. Parallel Input: From Master or previous Slave in a parallel machine set up.
13. Parallel Output: To Slave in a parallel machine set up

FIGURE B.3 - CASE BACK COMPONENTS

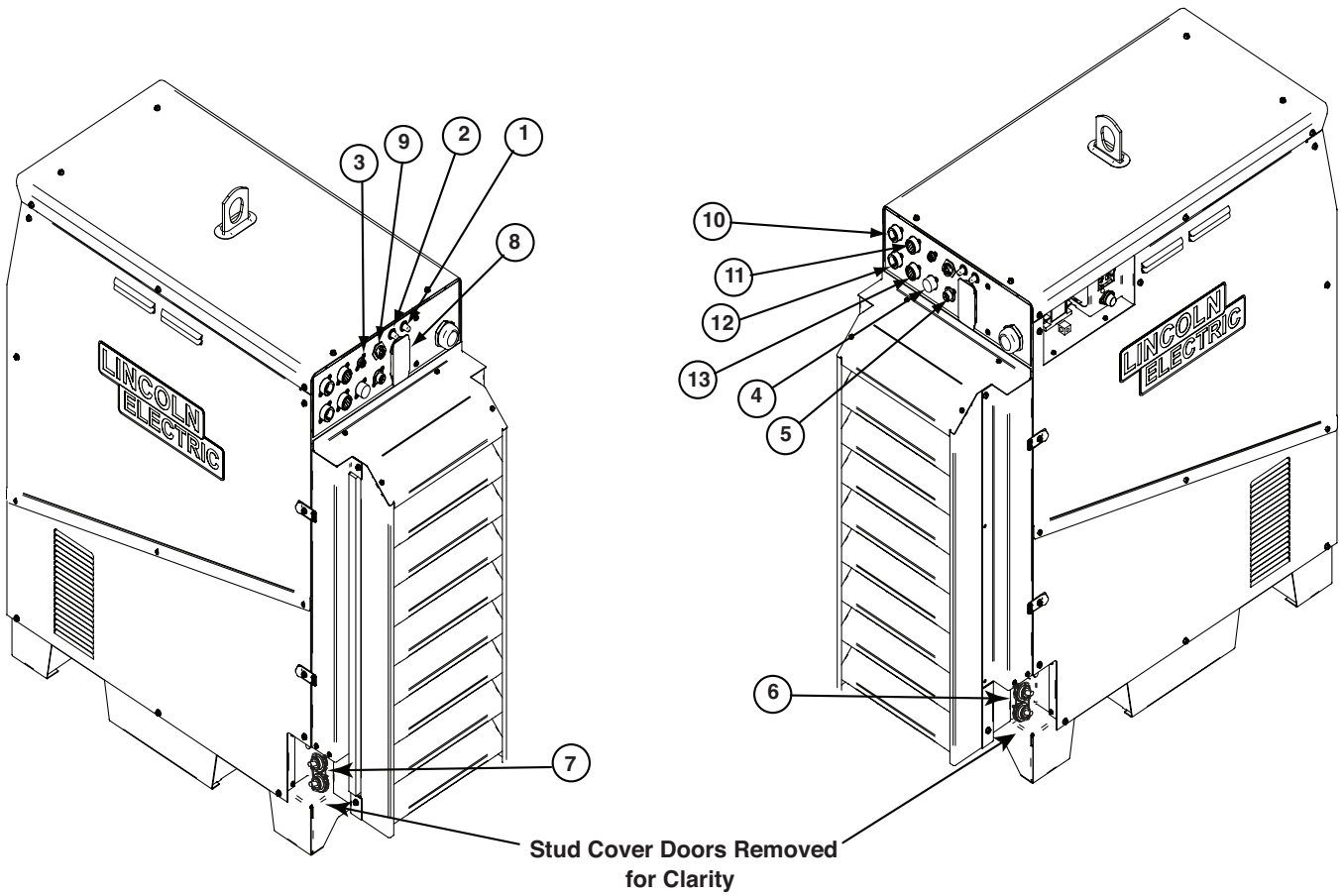
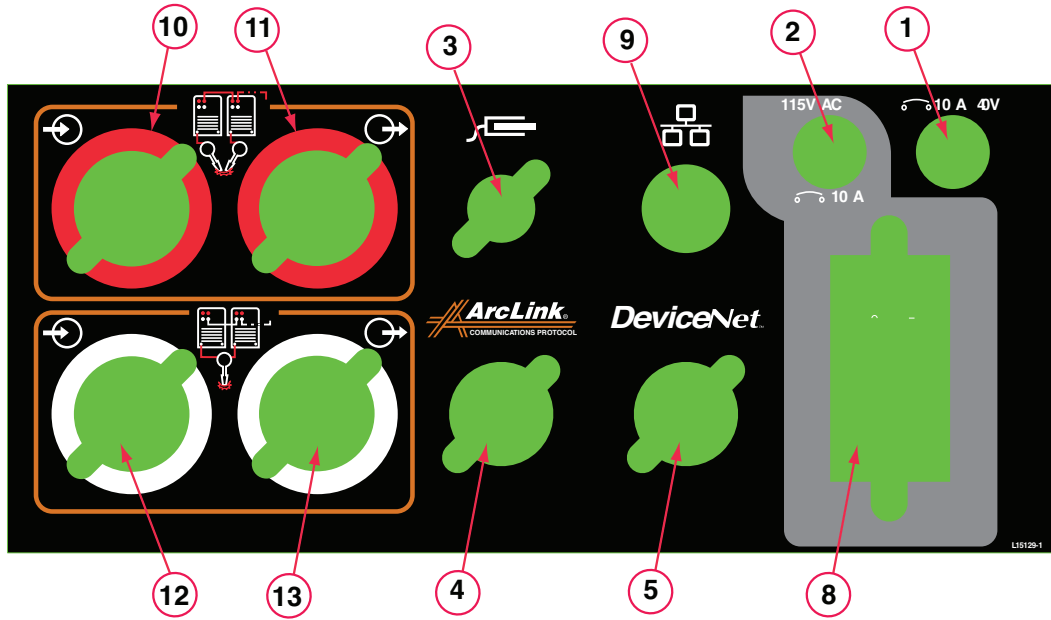

POWER-UP SEQUENCE

When power is applied to the Power Wave® AC/DC 1000® SD, the status lights will flash green for up to 60 seconds. During this time the Power Wave® AC/DC 1000® SD is performing a self test, and mapping (identifying) each component in the local ArcLink system. The status lights will also flash green as a result of a system reset or configuration change during operation. When the status lights become steady green the system is ready for use

If the status lights do not become steady green consult the troubleshooting section of this manual for further instruction.

DUTY CYCLE

The Power Wave® AC/DC 1000® SD is capable of welding 1000Amps, @ 44 Volts, at a 100% duty cycle.

COMMON WELDING PROCEDURES

MAKING A WELD

The serviceability of a product or structure utilizing the welding programs is and must be the sole responsibility of the builder/user. Many variables beyond the control of The Lincoln Electric Company affect the results obtained in applying these programs. These variables include, but are not limited to, welding procedure, plate chemistry and temperature, weldment design, fabrication methods and service requirements. The available range of a welding program may not be suitable for all applications, and the build/user is and must be solely responsible for welding program selection.

The steps for operating the Power Wave® AC/DC 1000® SD will vary depending upon the user interface of the welding system. The flexibility of the system lets the user customize operation for the best performance.

Consult the User Interface documentation for more detailed set up information. (MAXsa™ 10, Command Center, PLC, Robot etc..)

First, consider the desired welding procedures and the part to be welded. Choose an electrode material, diameter, and flux.

Second, find the program in the welding software that best matches the desired welding process. The standard software shipped with the Power Wave® AC/DC 1000® SD encompasses a wide range of common processes and will meet most needs. If a special welding program is desired, contact the local Lincoln Electric sales representative.

To make a weld, the Power Wave® AC/DC 1000® SD needs to know the desired welding parameters. Waveform Control Technology™ allows full customization of Strike, Run-in, Crater and other parameters for exacting performance.

OVERVIEW OF THE AC/DC SUBMERGED ARC PROCESS

The Power Wave® AC/DC 1000® SD combines the advantages of AC and DC Submerged Arc Welding (SAW) into a single power source. The limiting factor of AC-SAW welding has traditionally been the time it takes to transition from positive to negative polarity. This lag through the zero crossing can cause arc instability, penetration, and deposition problems in certain applications. The Power Wave® AC/DC 1000® SD utilizes the speed of an inverter based power source, and the flexibility of Waveform Control Technology™ to address this issue.

By adjusting the Frequency, Wave Balance and Offset of the AC waveform the operator can now control the balance (relationship) between the penetration of DC positive and the deposition of DC negative while taking full advantage of the reduction in arc blow associated with AC.

FIGURE B.4 - AC/DC SUBMERGED ARC PROCESS

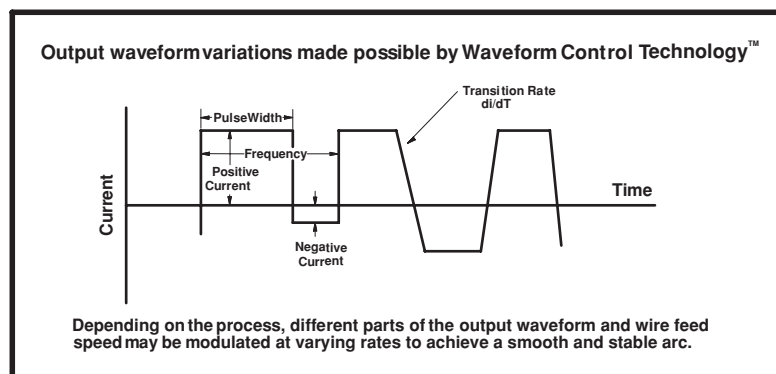

MULTIPLE ARC SYSTEM CONSIDERATIONS

Large scale SAW applications often employ multiple arcs to increase deposition rates. In multiple arc systems, magnetic forces created by like and opposing weld currents of adjacent arcs can result in arc interaction that can physically push or pull the arc columns together. See Figure B.5. To counteract this effect, the phase relationship between adjacent arcs can be set to alternate and equalize the duration of magnetic push and pull forces. This is accomplished through the synchronizing cables (K1785-xx). Ideally, the net result is a cancellation of the interacting forces. See Figure B.6.

FIG. B.5 - ARC INTERFERENCE

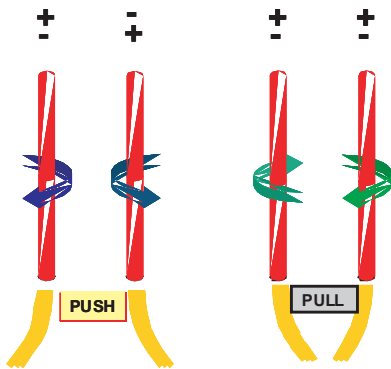
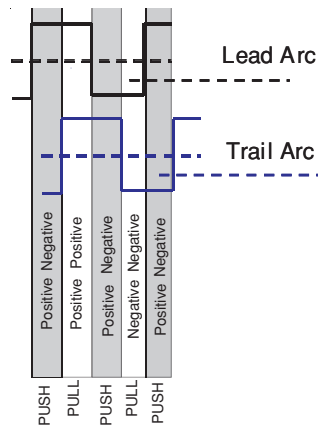

FIG. B.6 SYNCHRONIZED ARCS



CAUTION

Never simultaneously touch electrically "hot" parts in the electrode circuits of two different welders. The electrode to electrode no load voltage of multiple arc systems with opposite polarities can be double the no load voltage of each arc. Consult the Safety information located at the front of the Instruction Manual for additional information.

BASIC MODES OF OPERATION

CONSTANT CURRENT (CC)

- Operator presets Current and desired Voltage.
- The Power Source:
 - Goal is to maintain a constant arc length.
 - Drives a constant Current.
 - Synergically Controls WFS to Maintain Voltage at the desired Set point.
- Arc Length is proportional to Voltage.
- Traditionally used for larger diameter wires and slower travel speeds.

FIGURE B.7 - CONSTANT CURRENT

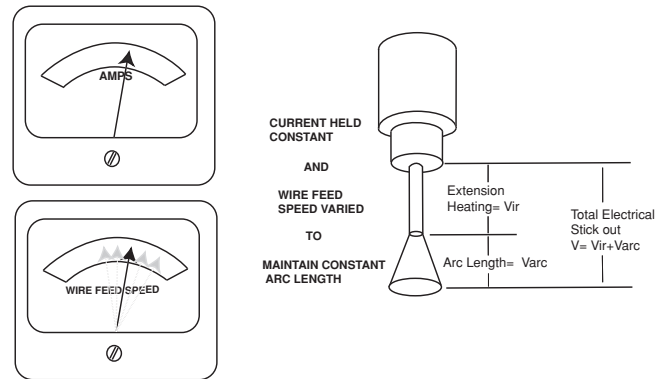

CONSTANT VOLTAGE (CV)

- Operator presets Wire Feed Speed and desired Voltage
- The Power Source:
 - Goal is to maintain a constant arc length.
 - Commands constant wire feed speed
 - Synergically Controls Current to Maintain Voltage at the desired Set point
- Arc Length is proportional to Voltage
- Traditionally used for smaller diameter wires and faster travel speeds.

FIGURE B.8

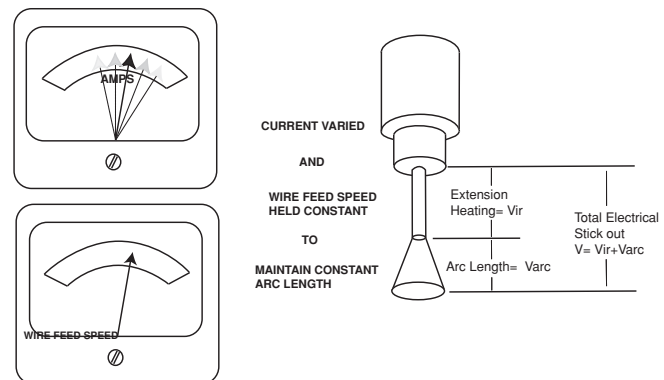

WELD SEQUENCE

The weld sequence defines the weld procedure from beginning to end. The Power Wave® AC/DC 1000® SD not only provides adjustment of basic welding parameters, but also allows the operator to fine tune the start and finish of each weld for superior performance.

All adjustments are made through the user interface. Because of the different configuration options, your system may not have all of the following adjustments. Regardless of availability, all controls are described below.

START OPTIONS

The Delay, Strike, Start, and Upslope parameters are used at the beginning of the weld sequence to establish a stable arc and provide a smooth transition to the welding parameters.

- **ARC DELAY** inhibits the wire feed for up to 5 seconds to provide an accurate weld start point. Typically used in multi-arc systems.
- **Strike** settings are valid from the beginning of the sequence (Start Button Pressed) until the arc is established. They control Run-in (speed at which the wire approaches the workpiece), and provide the power to establish the arc. Typically output levels are increased and WFS is reduced during the Strike portion of the weld sequence
- **Start** values allow the arc to become stabilized once it is established. Extended Start times or improperly set parameters can result poor starting
- **Upslope** determines the amount of time it takes to ramp from the Start parameters to the Weld parameters. The transition is linear and may be up or down depending on the relationship between the Start and Weld settings.

END OPTIONS

The **Downslope, Crater, Burnback and Restrike Timer** parameters are used to define the end of the weld sequence.

- **Downslope** determines the amount of time it takes to ramp from the Weld parameters to the Crater parameters. The transition is linear and may be up or down depending on the relationship between the Weld and Crater settings.
- **Crater** parameters are typically used to fill the crater at the end of the weld, and include both time and output settings.
- **Burnback** defines the amount of time the output remains on after the wire has stopped. This feature is used to prevent the wire from sticking in the weld puddle, and condition the end of the wire for the next weld. A Burnback time of 0.4 sec is sufficient in most applications. The output level for Burnback is the same level as the last active weld sequence state (either Weld or Crater).
- **Restrike Timer** is used to protect the welding system and/or work piece being welded. If the arc goes out for any reason (short circuit or open circuit), the Power Wave® AC/DC 1000® SD will enter a Re-strike state and automatically manipulate the WFS and output in an attempt to re-establish the arc. The Re-strike timer determines how long the system will attempt to re-establish the arc before it shuts down.
 - A Re-strike time of 1 to 2 sec is sufficient in most applications.
 - A Re-Strike setting of "OFF" allows for infinite restriking attempts until a shutdown occurs.

FIGURE B.9 WELD SEQUENCE

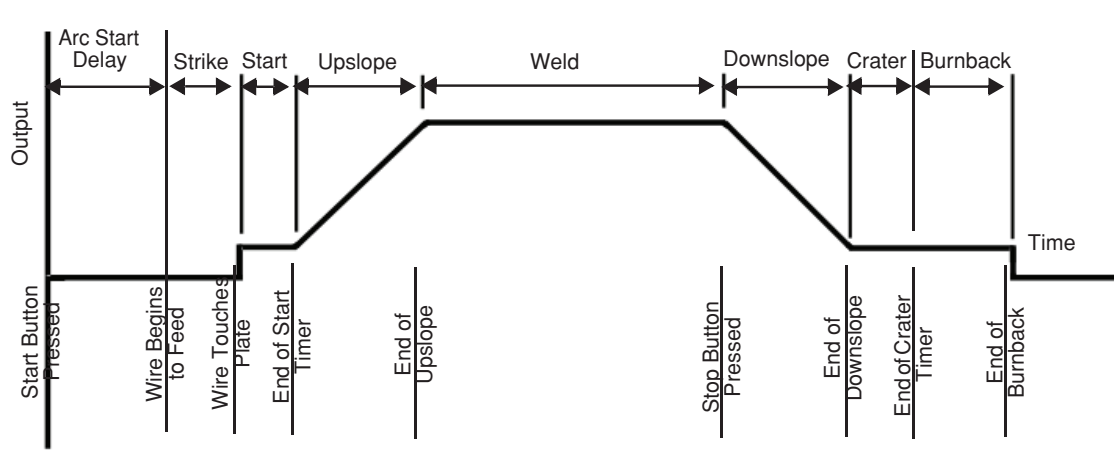

WELD PROCESS ADJUSTMENTS

Depending on the weld mode, there are a number of adjustments that can be made, including but not limited to Current, Voltage and WFS. These adjustments apply to either AC or DC processes, and control the basic parameters of the weld.

AC ADJUSTMENTS

In addition to the basic weld parameters, there are a number of unique adjustments related to the AC waveform of the Power Wave® AC/DC 1000® SD. These adjustments enable the operator to balance the relationship between penetration and deposition to tailor the output for specific applications.

WAVE BALANCE

- Refers to amount of time the waveform spends in DC+ portion of the cycle.
- Use Wave Balance to control the penetration and deposition of a given process. See Figure B.10.

FIGURE B.10 - WAVE BALANCE

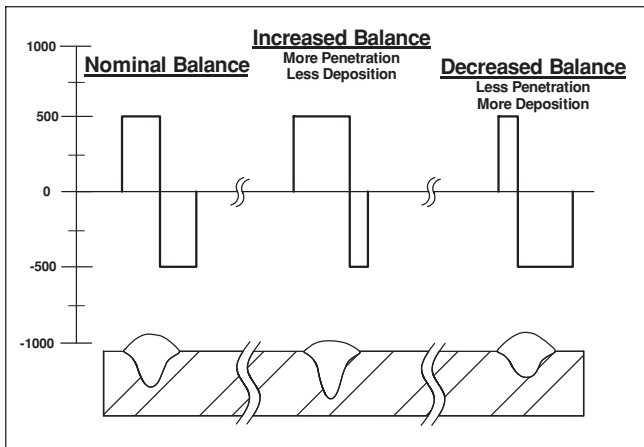

DC OFFSET

- Refers to +/- shift of the current waveform with respect to the zero crossing.
- Use Offset to control the penetration and deposition of a given process. See Figure B.11.

FIGURE B.11 - DC OFFSET

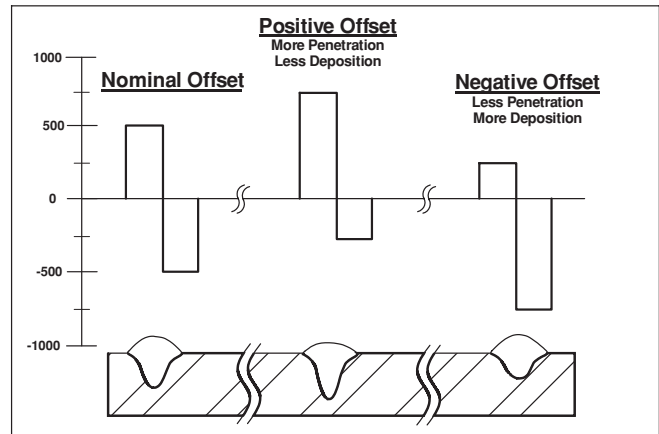

FREQUENCY

- Power Wave® AC/DC 1000® SD can produce Output Frequencies from 20 - 100Hz
- Use Frequency to help provide stability.
- Higher frequencies in multiple arc setups can help reduce arc interaction.
- Lower frequencies will help overcome output limitations due to inductance in the Weld Circuit. See Figure B.12.

FIGURE B.12 - FREQUENCY

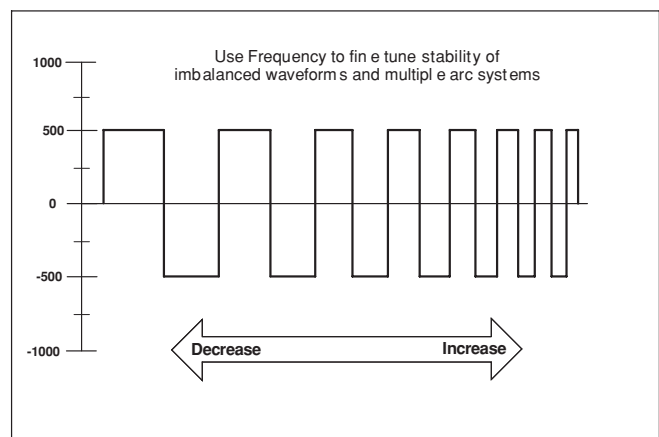

PHASE ADJUSTMENT FOR MULTIPLE ARC SYSTEMS

Phase

- The **phase relationship** between the arcs helps to minimize the magnetic interaction between adjacent arcs. It is essentially a time offset between the waveforms of different arcs, and is set in terms of an angle from 0 to 360°, representing no offset to a full period offset. The offset of each arc is set independently with respect to the lead arc of the system (ARC 1).

Recommendations:

- For balanced waveforms a phase relationship of 90° should be maintained between adjacent arcs.
- For unbalanced waveforms:
 - Avoid switching at same time.
 - Break up long periods of unchanged polarity relative to adjacent arcs.

TABLE B.1 - PHASE RELATIONSHIP

	ARC 1 Lead	ARC 2 Trail	ARC 3 Trail	ARC 4 Trail	ARC 5 Trail	ARC 6 Trail
2 Arc System	0°	90°	X	X	X	X
3 Arc System	0°	90°	180°	X	X	X
4 Arc System	0°	90°	180°	270°	X	X
5 Arc System	0°	90°	180°	270°	0°	X
6 Arc System	0°	90°	180°	270°	0°	90°

PHASE RELATIONSHIP

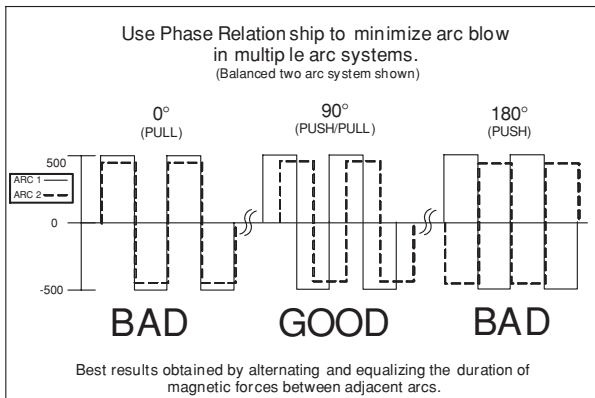

OPTIONS AND ACCESSORIES are available at
www.lincolnelectric.com

Follow these steps:

1. Go to www.lincolnelectric.com
2. In the **Search** field type E9.181 and click on the **Search** icon (or hit 'Enter' on the keyboard).
3. On the Results page, scroll down to the **Equipment** list and click on **E9.181**.

All of the information for the Power Wave® System accessories can be found in this document.

SOFTWARE TOOLS

Power Wave® AC/DC 1000® SD software tools and other documents related to the integration, configuration, and operation of the system is available at www.powerwavesoftware.com. Power Wave® Submerged Arc Utilities includes the following items and all of the documentation to support them.

Name	Purpose
<p>Weld Manager</p>	<p>Setup Ethernet address information, and apply security settings. Utility to diagnose Power Wave® problems, read system information, calibrate output voltage and current, test sense leads, and diagnose feed head issues. Can also setup and verify DeviceNet operation.</p> <ul style="list-style-type: none"> • Gear Box / Feeder Selection • Memory Lables • DeviceNet setup and Verification • UI setup (Lockout and Limits) • Ethernet setup and Verification • Diagnostic <ul style="list-style-type: none"> -snapshot -weldview -error lookup -inductance test -sense lead test • Calibration (I,V,WFS) • Cable Test <ul style="list-style-type: none"> -inductance -sense leads
<p>Command Center</p>	<p>AC/DC system tool to observe and log welding operation, verify DeviceNet welding configuration, and facilitate quality analysis.</p>
<p>Submerged Arc Cell Configuration</p>	<p>Used to configure and verify a multi-arc or parallel connected power source (more than one Power Wave® per arc) systems.</p> <ul style="list-style-type: none"> • Multi Arc setup • Generators Command Center connection file • Setup Verification <ul style="list-style-type: none"> -output cables (cables crossed) -software versions (Master to slave and Arc to Arc) -I/O verification (Master to Master and Master to slave) -sense lead -inductance test

SAFETY PRECAUTIONS



WARNING

ELECTRIC SHOCK can kill.



- Only Qualified personnel should perform this maintenance.
 - Turn the input power OFF at the disconnect switch or fuse box before working on this equipment.
- Do not touch electrically hot parts.

ROUTINE MAINTENANCE

Routine maintenance consists of periodically blowing out the machine, using a low-pressure airstream, to remove accumulated dust and dirt from the intake and outlet louvers, and the cooling channels in the machine.

The rear portion of the machine that contains the filter and the cooling fans slides out for easy access. Removing the four(4) clips and pulling back on the rear portion of the machine will provide access for cleaning the machine and checking the filter. The filter may be removed from the right side of the machine. See **Figure A.1**.

PERIODIC MAINTENANCE

Calibration of the Power Wave® AC/DC 1000® SD is critical to its operation. Generally speaking the calibration will not need adjustment. However, neglected or improperly calibrated machines may not yield satisfactory weld performance. To ensure optimal performance, the calibration of output Voltage and Current should be checked yearly.

CALIBRATION SPECIFICATION

Output Voltage and Current are calibrated at the factory. Generally speaking the machine calibration will not need adjustment. However, if the weld performance changes, or the yearly calibration check reveals a problem, use the calibration section of the **Weld Manager Utility** to make the appropriate adjustments.

The calibration procedure itself requires the use of a grid (Resistive Load Bank), and certified actual meters for voltage and current. The accuracy of the calibration will be directly affected by the accuracy of the measuring equipment you use. The **Weld Manager Utility** includes detailed instructions, and is available on the internet at powerwavesoftware.com under **Power Wave® Submerged Arc Utilities**.

HOW TO USE TROUBLESHOOTING GUIDE



WARNING

Service and Repair should only be performed by Lincoln Electric Factory Trained Personnel. Unauthorized repairs performed on this equipment may result in danger to the technician and machine operator and will invalidate your factory warranty. For your safety and to avoid Electrical Shock, please observe all safety notes and precautions detailed throughout this manual.

This Troubleshooting Guide is provided to help you locate and repair possible machine malfunctions. Simply follow the three-step procedure listed below.

Step 1. LOCATE PROBLEM (SYMPTOM).

This column describes possible symptoms that the machine may exhibit. Find the listing that best describes the symptom that the machine is exhibiting.

Step 2. POSSIBLE CAUSE.

The second column labeled "POSSIBLE CAUSE" lists the obvious external possibilities that may contribute to the machine symptom.

Step 3. RECOMMENDED COURSE OF ACTION

This column provides a course of action for the Possible Cause, generally it states to contact your local Lincoln Authorized Field Service Facility.

If you do not understand or are unable to perform the Recommended Course of Action safely, contact your local Lincoln Authorized Field Service Facility.



CAUTION

If for any reason you do not understand the test procedures or are unable to perform the tests/repairs safely, contact your **Local Lincoln Authorized Field Service Facility** for technical troubleshooting assistance before you proceed.

Observe all Safety Guidelines detailed throughout this manual

USING THE STATUS LED TO TROUBLESHOOT SYSTEM PROBLEMS

The Power Wave® AC/DC 1000® SD is equipped with one externally mounted status light. If a problem occurs it is important to note the condition of the status lights. **Therefore, prior to cycling power to the system, check the power source status light for error sequences as noted below.**

Included in this section is information about the power source Status LED and some basic troubleshooting charts for both machine and weld performance.

The STATUS LIGHT is a dual-color LED that indicates system errors. Normal operation is steady green. Error conditions are indicated in the following Table E.1.

TABLE E.1

Light Condition	Meaning
Steady Green	System OK. Power source is operational, and is communicating normally with all healthy peripheral equipment connected to its ArcLink network.
Blinking Green	Occurs during power up or a system reset, and indicates the POWER WAVE® is mapping (identifying) each component in the system. Normal for first 1-10 seconds after power is turned on, or if the system configuration is changed during operation.
Fast Blinking Green	Under normal conditions indicates Auto-mapping has failed. Also used by Weld Manager and Submerged Arc Cell Setup (available at www.powerwavesoftware.com) to identify the selected machine when connecting to a specific IP address.
Alternating Green and Red	<p>Non-recoverable system fault. If the Status lights are flashing any combination of red and green, errors are present. Read the error code(s) before the machine is turned off.</p> <p>Error Code interpretation through the Status light is detailed in the Service Manual. Individual code digits are flashed in red with a long pause between digits. If more than one code is present, the codes will be separated by a green light. Only active error conditions will be accessible through the Status Light.</p> <p>Error codes can also be retrieved with Weld Manager under System Status (available at www.powerwavesoftware.com). This is the preferred method, since it can access historical information contained in the error log.</p> <p>To clear the active error(s), turn power source off, and back on to reset.</p> <p>Not applicable.</p> <p>Not applicable.</p>
Steady Red	
Blinking Red	



CAUTION

If for any reason you do not understand the test procedures or are unable to perform the tests/repairs safely, contact your **Local Lincoln Authorized Field Service Facility** for technical troubleshooting assistance before you proceed.

Observe all Safety Guidelines detailed throughout this manual

ERROR CODES FOR THE POWER WAVE®

The following is a partial list of possible error codes for the Power Wave® AC/DC 1000® SD. For a complete listing consult the Service Manual for this machine.

POWER SOURCE—WELD CONTROLLER		
Error Code #	LECO (FANUC#)	Indication
31	49	Primary (Input) overcurrent error. Excessive Primary current present. May be related to a switch board or output rectifier failure.
32	50	Capacitor "A" under voltage (right side facing the Switch PC Board) Capacitor bank "B" under voltage (left side facing the Switch PC Board) Low voltage on the main capacitors. May be caused by improper input configuration, or an open/short circuit in the primary side of the machine.
33	51	
34	52	Capacitor "A" over voltage (right side facing the Switch PC Board) Capacitor "B" over voltage (left side facing the Switch PC Board) Excess voltage on the main capacitors. May be caused by improper input configuration, excessive line voltage, or improper capacitor balance (see Error 43)
35	53	
36	54	Thermal error Indicates over temperature. Usually accompanied by Thermal LED. Check fan operation. Be sure process does not exceed duty cycle limit of the machine. Also acts with a malfunction.
37	55	Softstart (pre-charge) error Capacitor precharge failed. Usually accompanied by codes 32 and 33.
39	57	Misc. hardware fault Unknown glitch has occurred on the fault interrupt circuitry. Sometimes caused by primary over current fault, or intermittent connections in the thermostat circuit.
43	67	Capacitor delta error The maximum voltage difference between the main capacitors has been exceeded. May be accompanied by errors 32-35. May be caused by an open or short in the primary or secondary circuit(s).
Other	see complete listing	A complete list of error codes is available in Weld Manager under Tools -> Lookup Error (available at www.powerwavesoftware.com). Error codes that contain three or four digits are defined as fatal errors. These codes generally indicate internal errors on the Power Source Control Board. If cycling the input power on the machine does not clear the error, contact the Service Department



CAUTION

If for any reason you do not understand the test procedures or are unable to perform the tests/repairs safely, contact your **Local Lincoln Authorized Field Service Facility** for technical troubleshooting assistance before you proceed.

Observe all Safety Guidelines detailed throughout this manual

PROBLEMS (SYMPTOMS)	POSSIBLE CAUSE	RECOMMENDED COURSE OF ACTION
BASIC MACHINE PROBLEMS		
Major physical or electrical damage is evident when the sheet metal covers are removed.	None	1. Contact your local authorized Lincoln Electric Field Service facility for technical assistance.
Input fuses keep blowing	1. Improperly sized input fuses.	1. Make sure fuses are properly sized. See installation section of this manual for recommended sizes.
	2. Improper Weld Procedure requiring output levels in excess of machine rating.	2. Reduce output current, duty cycle, or both.
	3. Major physical or electrical damage is evident when the sheet metal covers are removed.	3. Contact your local authorized Lincoln Electric Field Service facility for technical assistance.
Machine will not power up (no lights)	1. No Input Power.	1. Make sure input supply disconnect has been turned ON. Check input fuses. Make certain that the Power Switch (SW1) on the power source is in the "ON" position.
	2. Fuse F1 (in reconnect area) may have blown.	2. Power Down and replace the fuse.
	3. Circuit breaker CB1 (on the control panel) may have tripped.	3. Power Down and reset CB1.
	4. Improper input voltage selection (multiple input voltage machines only).	4. Power down, check input voltage reconnect according to diagram on reconnect cover.

 **CAUTION**

If for any reason you do not understand the test procedures or are unable to perform the tests/repairs safely, contact your **Local Lincoln Authorized Field Service Facility** for technical troubleshooting assistance before you proceed.

POWER WAVE™ AC/DC 1000 (380/400/460/500/575) POWER SOURCE WIRING DIAGRAM

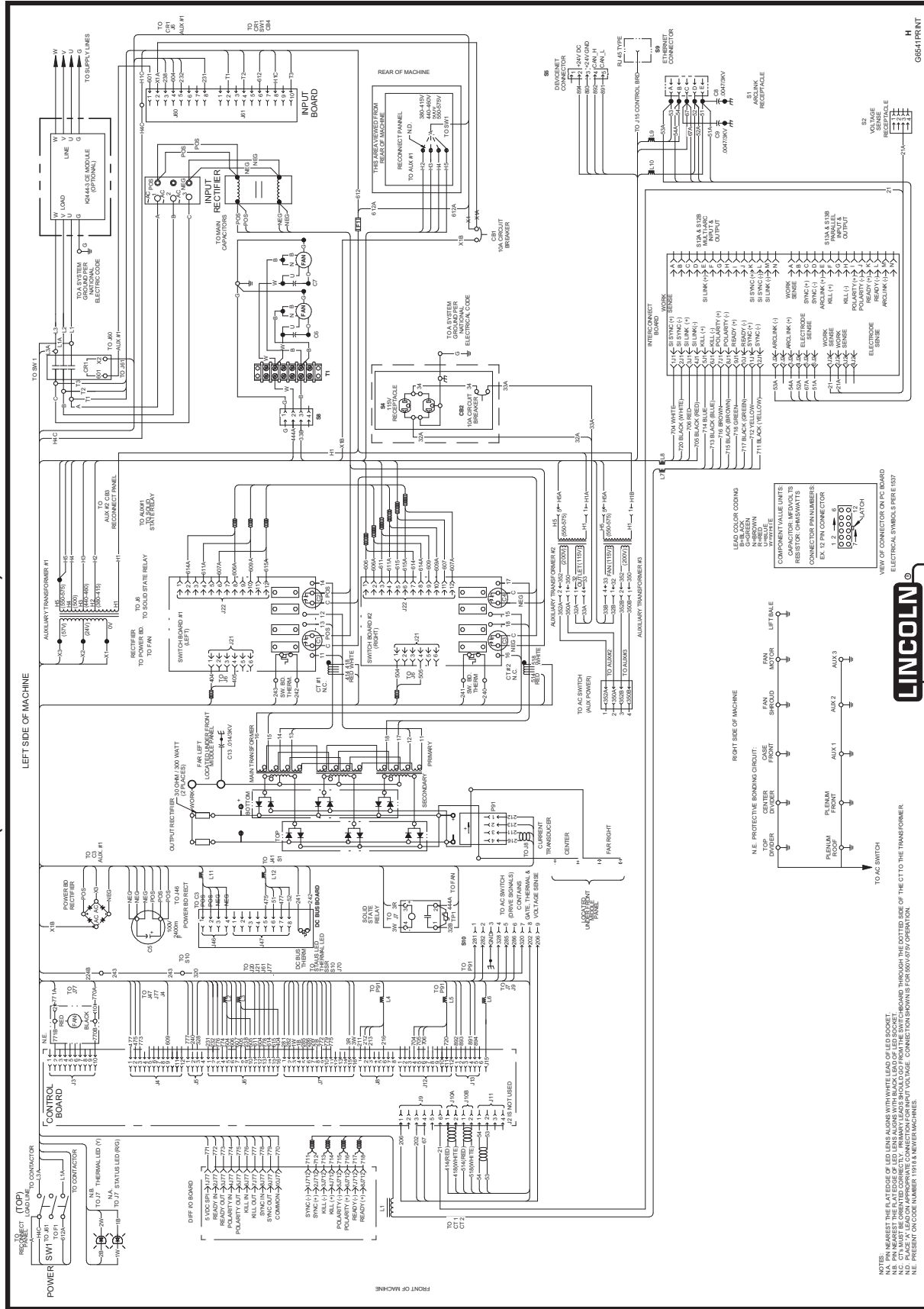

CLEVELAND, OHIO, U.S.A.



NOTE: This diagram is for reference only. It may not be accurate for all machines covered by this manual. The specific diagram for a particular code is pasted inside the machine on one of the enclosure panels. If the diagram is illegible, write to the Service Department for a replacement. Give the equipment code number.

POWER WAVE® AC/DC 1000® SD(380/400/460/500/575) AC SWITCH WIRING DIAGRAM

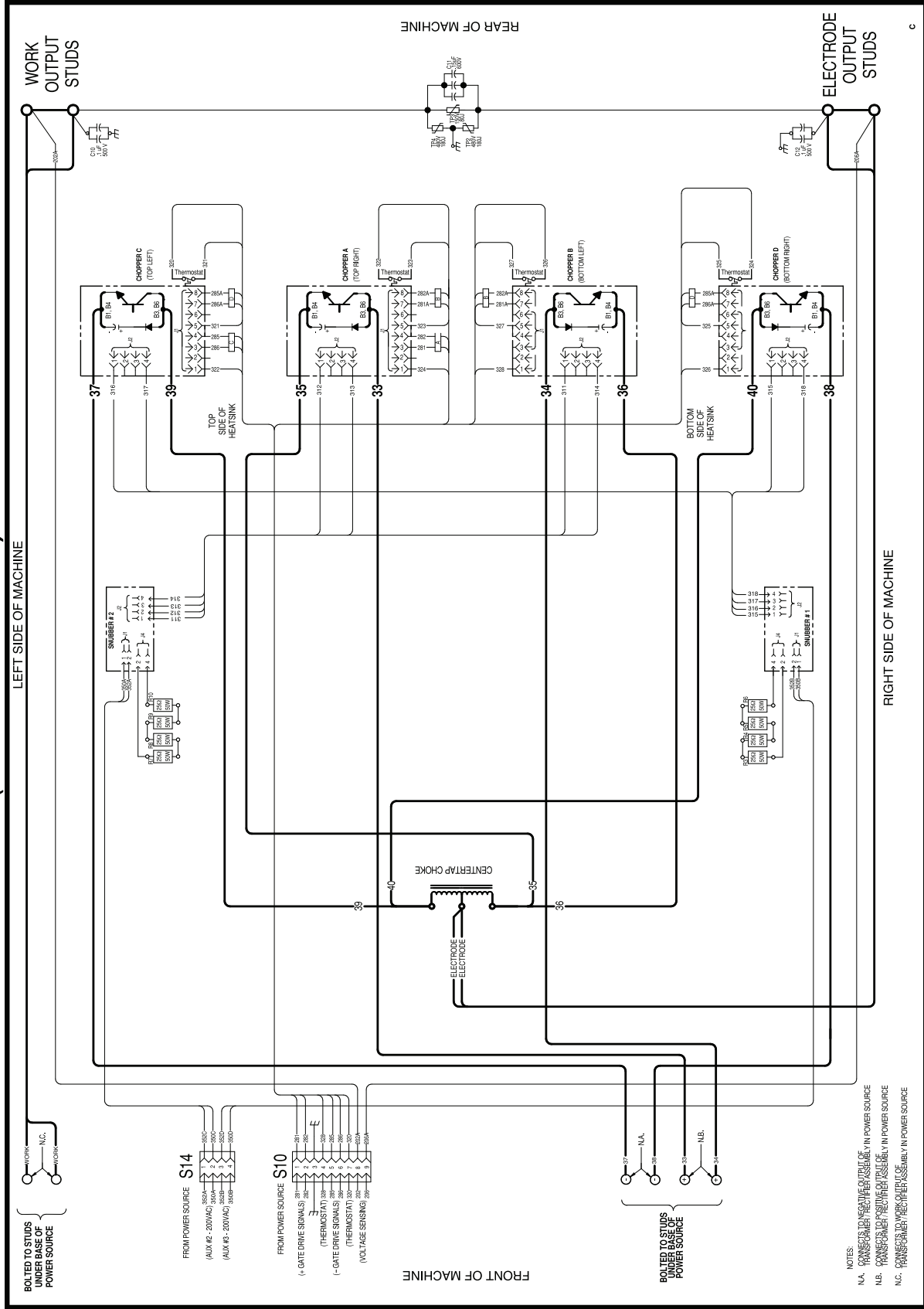

G6542

NOTE: This diagram is for reference only. It may not be accurate for all machines covered by this manual. The specific diagram for a particular code is pasted inside the machine on one of the enclosure panels. If the diagram is illegible, write to the Service Department for a replacement. Give the equipment code number.

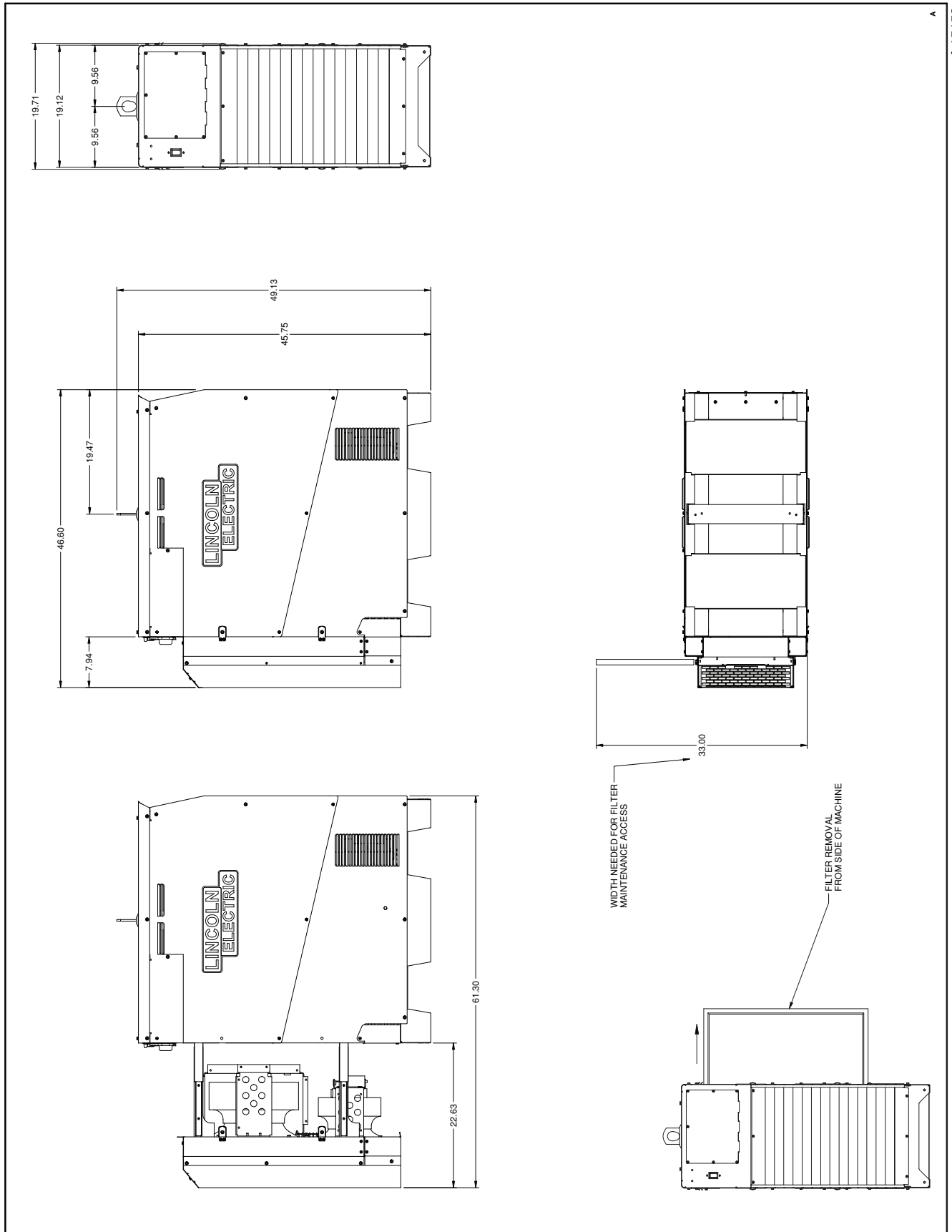

L15150



Service Navigator 2.0

Power Wave AC/DC 1000 SD - 12385

THIS PAGE INTENTIONALLY LEFT BLANK

Index of Sub Assemblies - 12385

KEY	PART NUMBER	DESCRIPTION	QTY
	P-612-A	Index of Sub Assemblies	AR
	P-612-B.2	Miscellaneous Items	AR
1	P-612-C	Case Front Assembly	AR
2	P-612-D	Plenum Roof & Input Power Assembly	AR
3	P-612-E	Impeller Assembly	AR
4	P-612-F	Base Plenum Sides & Lift Bale Assembly	AR
5	P-612-G	Rectifier & Heatsink Assembly	AR
6	P-612-H	AC Switch Assembly	AR
7	P-612-J	AC Switch Sub Assembly	AR
8	P-612-K	Auxiliary Transformers & Harmonic Filter	AR
9	P-612-L	Covers Assembly	AR

Index of Sub Assemblies - 12385

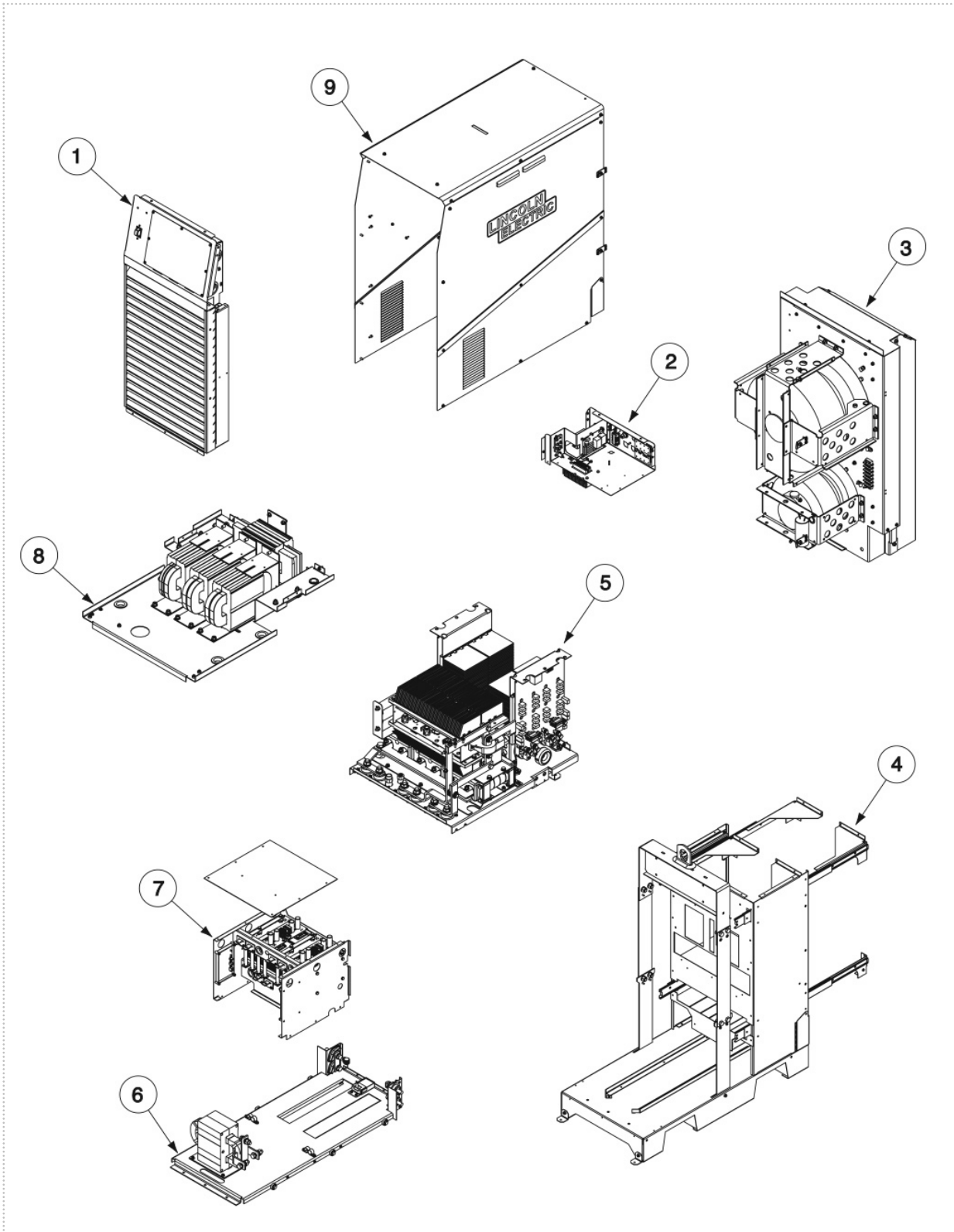

P-612-A.jpg

Miscellaneous Items

KEY	PART NUMBER	DESCRIPTION	QTY
	9SG6407	WIRING HARNESS	1
	9SM19969-12	ETHERNET PATCH CABLE ASBLY	1
	9SM22084	AUXILIARY POWER INTERFACE CABLE	1
	9SS18250-955	PLUG & LEAD ASBLY	1
	9SG6501	WIRING HARNESS	1
	9SS24701-9	CONNECTOR SEALED PLUG	1
	9SS24701-4	CONNECTORSEALEDPLUG	1
	9SS18250-961	PLUG & LEAD ASBLY	1
	9SM20130	ARC SENSE LEAD	1

Case Front Assembly

KEY	PART NUMBER	DESCRIPTION	QTY
	9SG6430	Case Front Assembly	1
1A	9SL13989	CASE FRONT WELDED ASBLY	1
2A	9SL11832-3	40V DC BUS PC BD ASBLY	1
	9ST7028-52	\	4
	9ST9187-13	#10-24HLN-1817/1-NYLON INSERT	4
3A	9ST13637-6	DIODE-BRIDGE35A400VF-W1-PH	1
	9SS9262-27	PLAIN WASHER	1
	9SE106A-1	LOCKWASHER	1
	9SCF000010	#10-24HN	1
4A	9ST13359-12	THERMOSTAT	1
	9SS8025-80	SELF TAPPING SCREW	2
5A	9SS13490-157	CAPACITOR-ALEL24000100V+300/-10%	1
5B	9SS27974	CAPACITOR BRACKET	1
5C	9SS22745-3	CAPACITOR INSULATION	1
5D	9SE106A-2	LOCKWASHER	2
5E	9SCF000017	1/4-20HN	2
6A	9SS15317-5	RELAY	1
	9SCF000033	#8-32X.50RHS	2
	9SS9262-3	PLAIN WASHER	2
	9ST4291-A	LOCKWASHER	2
7	9ST12380-12	BUSHING	3
8	9ST12380-4	BUSHING	1
9A	9SS27568-9	CONTROL BOARD ASBLY	1
9B	9ST9187-13	#10-24HLN-1817/1-NYLON INSERT	4
10A	9SL15006-1	DIFFERENTIAL I/O PC BD ASBLY	1
10B	9ST9187-13	#10-24HLN-1817/1-NYLON INSERT	4
11A	9SS20030	LINE SWITCH	1
11C	9SS25384	WEATHERPROOF COVER	1
	9SE106A-13	LOCKWASHER	2
11E	9SCF000338	#6-32X.50PPNHS	2
	9SS9262-23	PLAIN WASHER	2
	9SE106A-2	LOCKWASHER	2
	9SS11604-65	SET SCREW	2
12D	9SCF000198	1/4-28HN	2

Case Front Assembly

KEY	PART NUMBER	DESCRIPTION	QTY
	9ST9187-13	#10-24HLN-1817/1-NYLON INSERT	4
20A	9SG6420	LOUVER WELDED ASBLY	1
20B	9SM22028	PROTECTIVE COVER - CASE FRONT	1
	9SS8025-91	SELF TAPPING SCREW	12
21	9SM24717	ACCESS DOOR & FAN ASBLY	1
21C	9SM22669	CONTROL PANEL ACCESS DOOR	1
21D	9SS29447	FAN ASBLY	1
	9SS9225-99	SELF TAPPING SCREW	2
21F	9SS28941	FAN BRACKET	1
	9ST9187-13	#10-24HLN-1817/1-NYLON INSERT	2
	9SS9225-61	THREAD FORMING SCREW (ROLLING)	7
25A	9SM22008	RIGHT SUPPORT BRACKET	1
25B	9SM22007	LEFT SUPPORT BRACKET	1
	9SS8025-91	SELF TAPPING SCREW	4
	9ST15120	MOV ASBLY	1
	9SS23093-1	LED LENS CLEAR	2
	9SS23094-1	RETAINING O RING	2
36	9SG6548	NAMEPLATE	1
37	9SG6548	NAMEPLATE	1
	9SM22193	DIP SWITCH SETUP DECAL	1
	9ST13657-4FA	YELLOW LED	1
	9ST13657-7H24	LED-T-1 3/4BI-COLORRED/GREEN	1

Case Front Assembly

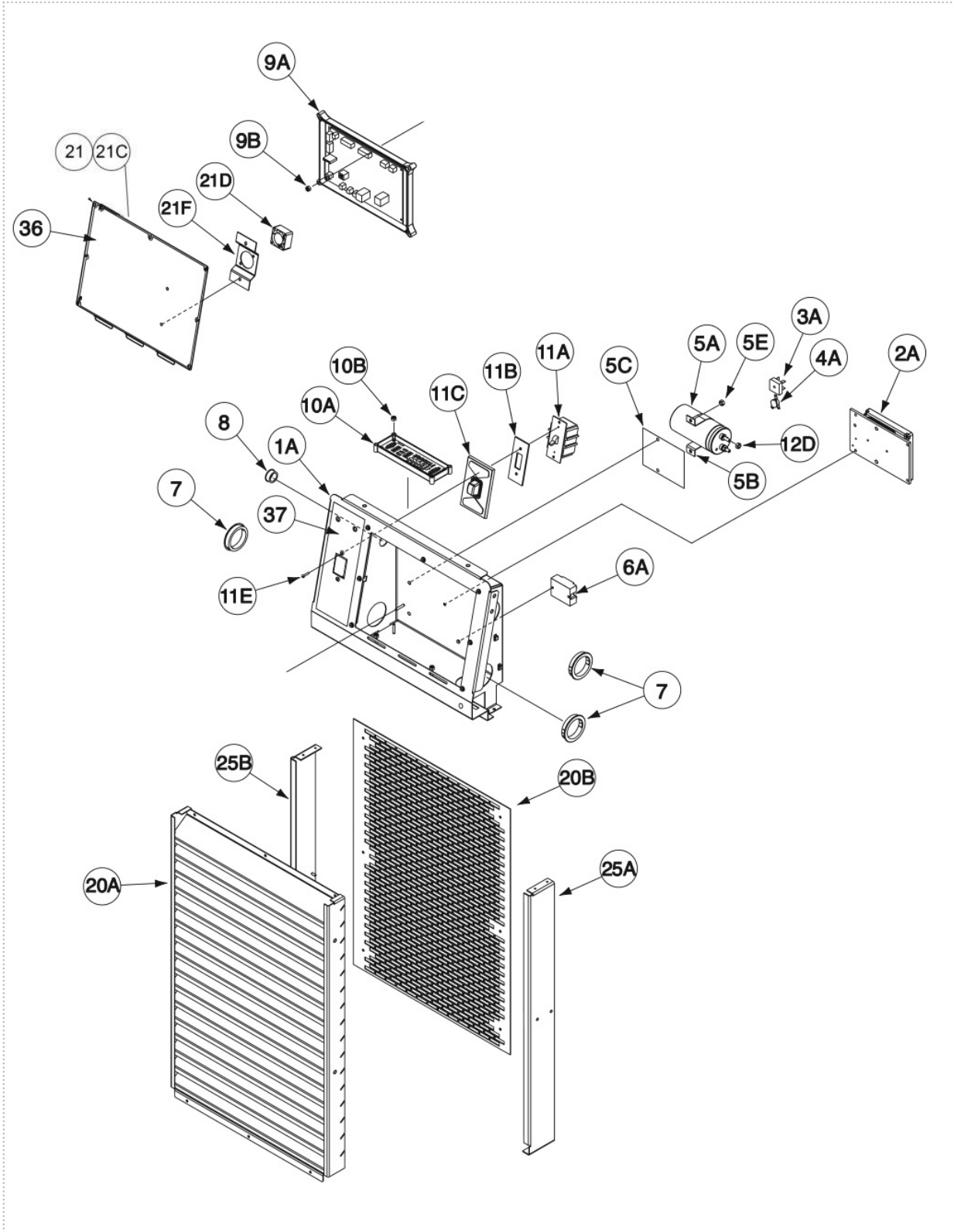

P-612-C.jpg

Plenum Roof & Input Power Assembly

KEY	PART NUMBER	DESCRIPTION	QTY
	9SG6431-1	Plenum Roof & Input Power Asbly	1
1A	9SL15004	PLENUM ROOF WELDED ASBLY	1
	9SL15129	NAMEPLATE	1
2A	9SL15086	INPUT POWER PANEL	1
	9SS8025-91	SELF TAPPING SCREW	3
3A	9SM12161-94	CONTACTOR	1
	9SS9262-27	PLAIN WASHER	4
	9SE106A-1	LOCKWASHER	4
	9SCF000010	#10-24HN	4
4A	9SL11396-2	INPUT PC BD ASBLY	1
4B	9SS14020-7	SUPPORT-PCBNUTEXPPCB-ONLY0.50	6
4C	9SS8025-97	SELF TAPPING SCREW	6
	9SS18250-1005	PLUG & LEAD ASBLY	1
5A	9ST12386	FUSE HOLDER	1
5B	9ST10728-54	FUSE	1
5C	9SCF000053	#8-32X.625RHS	2
	9SS9262-3	PLAIN WASHER	2
	9ST4291-A	LOCKWASHER	2
	9SCF000042	#8-32HN	2
6A	9SM19656	RECONNECT PANEL	1
6B	9ST14530-1	RECEPTACLE	4
	9ST12584-11	BLIND RIVET	2
	9SS9262-136	PLAIN WASHER	4
6E	9SL15129	NAMEPLATE	1
7A	9SM15454-13	DIODE-BRIDGE160A1600VF-W3 PH	1
	9SS25930-1	142TORX BUTTON HEAD SCREW 1/4-20X.88	2
	9ST12735-4	SPRING WASHER	2
8A	9SM19349-1	OUTPUT RECTIFIER HEATSINK	1
	9SCF000012	1/4-20X.50HHCS	3
	9ST9860-6	LOCKWASHER	3
10A	9SS20184-2	RECEPTACLE REWORK	1
10B	9SM16996	RECEPTACLE COVER	1
10C	9SS21088	RECEPTACLEGASKET	1
	9ST11525-1	SPEED NUT#10-24	2

Plenum Roof & Input Power Assembly

KEY	PART NUMBER	DESCRIPTION	QTY
	9SS9225-63	THREAD FORMING SCREW (CUTTING)	2
	9SL15129	NAMEPLATE	1
11A	9ST12287-20	CIRCUIT BREAKER-10A250VAC	2
11B	9SS22061-3	SEALING BOOT	2
12	9SM19969-9	ETHERNET RECEPTACLE BULKHEAD	1
13	9SS19999-3	CORD GRIP CONNECTOR	1
14A	9SM22124-1	INTERCONNECT PC BD ASBLY	1
	9SS8025-96	SELF TAPPING SCREW	8
	9SS11604-48	SET SCREW	1
17	9SL15129	NAMEPLATE	1
	9SS18250-1005	PLUG & LEAD ASBLY	1
22	9SS25219	CAPACITOR ASBLY	1
23	9SS17062-11	CABLE CONNECTOR CAP	4
24	9SM19969-4	ETHERNET RECEPTACLE COVER	1
	9ST14798-1	IDENTIFICATION STICKER (CR1)	1
	9SS8025-91	SELF TAPPING SCREW	7
30A	9SS12021-73	BOX RECEPTACLE SOLID SHELL	1
30B	9SS17062-10	CABLE CONNECTOR CAP	1
	9ST11577-58	CAPACITOR-CERAMIC DISC	1
31	9SS24700-4	CONNECTORSEALEDRECEPTACLE	1
32	9SS18657	SQUARE FLANGE FEMALE RECEPTACLE	1
33A	9SS24883	DEVICE NET CONNECTORMALE CONTACTS	1
33B	9ST13837-7	PROTECTIVE CAP	1
	9SS25438	CONNECTOR ADAPTER PLATE	1
34	9SS28097-1	RATING PLATE	1
	9ST13260-4	DECAL-EARTH GROUND CONN	1

Plenum Roof & Input Power Assembly

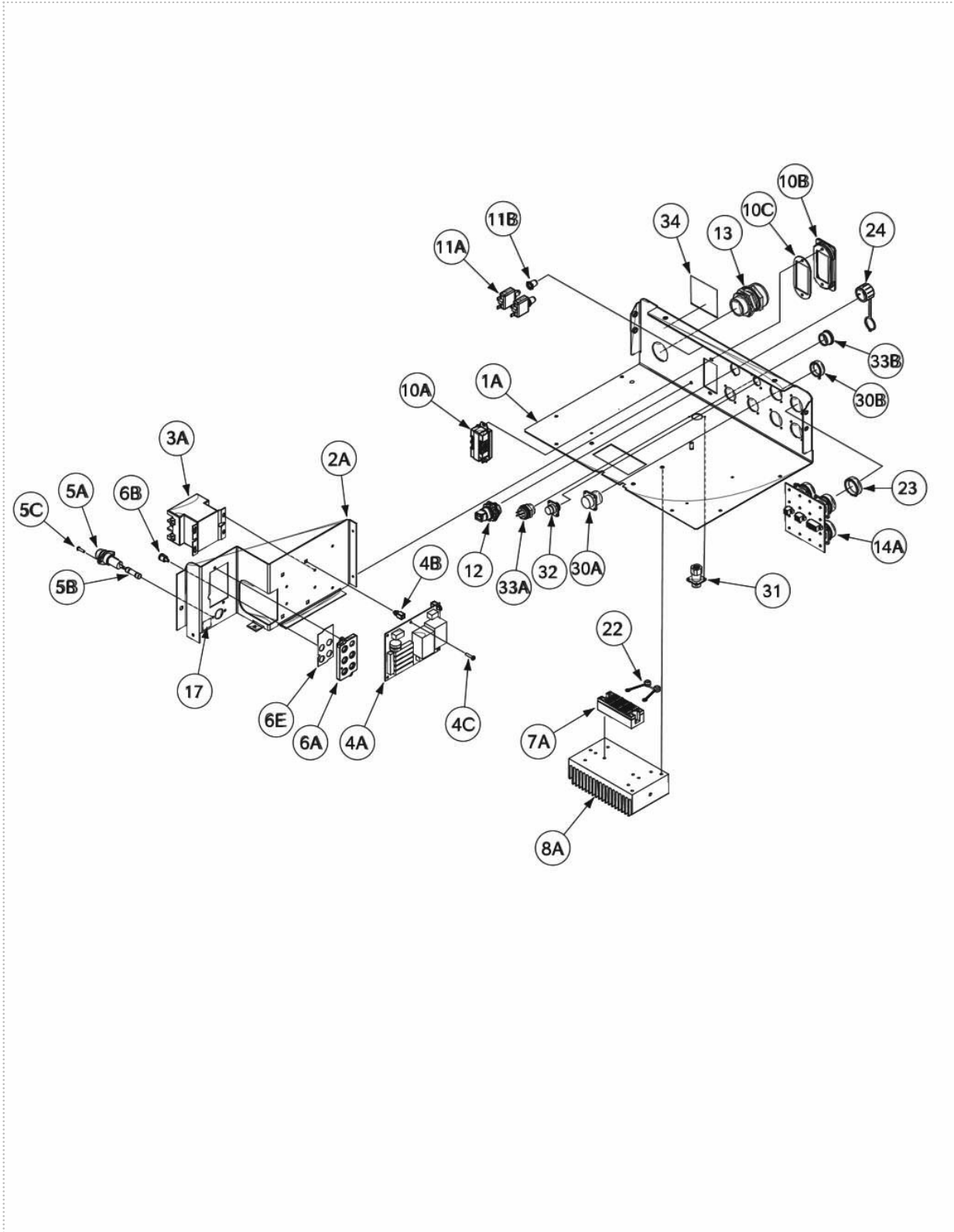

P-612-D.jpg

Impeller Assembly

KEY	PART NUMBER	DESCRIPTION	QTY
	9SG6578	Impeller Frame Assembly	1
1A	9SG6413	IMPELLER MOUNTING FRAME	1
	9ST9187-13	#10-24HLN-1817/1-NYLON INSERT	8
2A	9SM22217	INLET CONE (355MM)	1
2B	9SE106A-3	LOCKWASHER	4
2C	9SS9262-121	PLAIN WASHER	4
2D	9SCF000029	5/16-18HN	4
	9SCF000040	5/16-18X.75HHCS	4
3A	9SM22218	INLET CONE (250MM)	1
3B	9SS9262-98	PLAIN WASHER	4
3C	9SE106A-2	LOCKWASHER	4
3D	9SCF000017	1/4-20HN	4
3E	9SCF000014	1/4-20X.75HHCS	4
4A	9SL15147	IMPELLER ASBLY	1
	9SS9262-98	PLAIN WASHER	8
	9SE106A-2	LOCKWASHER	8
	9SCF000017	1/4-20HN	8
5A	9SL15148	IMPELLER ASBLY	1
	9SS9262-98	PLAIN WASHER	4
	9SE106A-2	LOCKWASHER	4
	9SCF000017	1/4-20HN	4
7A	9SS8542	TERMINAL STRIP	1
	9ST9187-13	#10-24HLN-1817/1-NYLON INSERT	2
11A	9SM22003	LOUVER CAP	2
11B	9SS8025-91	SELF TAPPING SCREW	8
	9ST9187-13	#10-24HLN-1817/1-NYLON INSERT	8
	9SS8025-91	SELF TAPPING SCREW	4
16A	9SG6414	CASE BACK LOUVER WELDED ASBLY	1
	9SS9225-68	THREAD FORMING SCREW (CUTTING)	6
17A	9SL15128	FILTER HOLDER	1
	9SS8025-91	SELF TAPPING SCREW	4
18A	9SL13978	LOUVER ROOF	1
18B	9SS8025-91	SELF TAPPING SCREW	4
19	9ST13259	GROUND DECAL	1

Impeller Assembly

KEY	PART NUMBER	DESCRIPTION	QTY
20	9ST13086-20	DECAL	1
21	9SS28117	IMPELLER SLIDE DECAL	1
22	9SM22301	WASHABLE AIR FILTER	1

Impeller Assembly

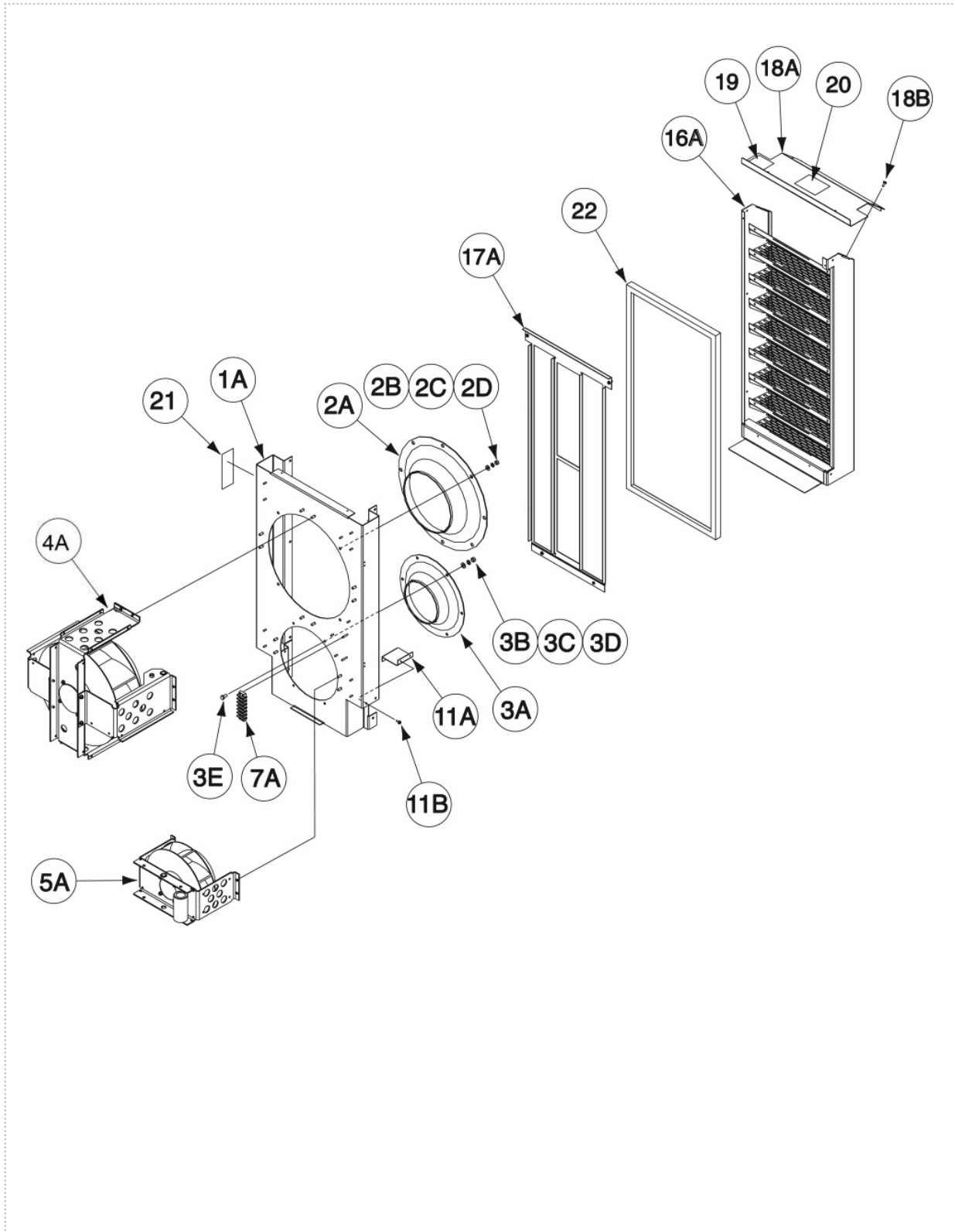

P-612-E.jpg

Base, Plenum Sides & Lift Bale Assembly

KEY	PART NUMBER	DESCRIPTION	QTY
1	9SG6411	BASE WELDED ASBLY	1
2A	9SM22002	LIFT BALE SUPPORT	1
	9SS9225-68	THREAD FORMING SCREW (CUTTING)	2
3A	9SL15055	LEFT GUIDE RAIL	1
3B	9SL15056	RIGHT GUIDE RAIL	1
3C	9SS8025-91	SELF TAPPING SCREW	8
4A	9SM22206	AC SWITCH CATCH	1
4B	9SS8025-91	SELF TAPPING SCREW	2
5A	9SG6587	RIGHT PLENUM SIDE SUB-ASBLY	1
	9SS9225-68	THREAD FORMING SCREW (CUTTING)	2
6A	9SG6588	LEFT PLENUM SIDE SUB-ASBLY	1
	9SS9225-68	THREAD FORMING SCREW (CUTTING)	2
7A	9SM22107	RIGHT OUTPUT STUD DOOR	1
	9SS8025-91	SELF TAPPING SCREW	2
7C	9SS9225-68	THREAD FORMING SCREW (CUTTING)	1
8A	9SM22109	LEFT OUTPUT STUD DOOR	1
	9SS8025-91	SELF TAPPING SCREW	2
	9SS9225-68	THREAD FORMING SCREW (CUTTING)	1
9A	9SM22063	PLENUM BOTTOM	1
	9SS8025-91	SELF TAPPING SCREW	2
10A	9SG6444	PLENUM BACK	1
	9SS8025-91	SELF TAPPING SCREW	2
11A	9SM22082	OUTPUT STUD COVER	1
11B	9SM22081	OUTPUT STUD COVER	1
	9SS8025-91	SELF TAPPING SCREW	2
	9SS9262-27	PLAIN WASHER	2
	9SE106A-1	LOCKWASHER	2
	9SCF000010	#10-24HN	2
	9ST12584-7	RIVET	2
12A	9SM22022	PLENUM DIVIDER	1
	9SS8025-91	SELF TAPPING SCREW	2
	9SS9262-27	PLAIN WASHER	2
	9SE106A-1	LOCKWASHER	2
	9SCF000010	#10-24HN	2

Base, Plenum Sides & Lift Bale Assembly

KEY	PART NUMBER	DESCRIPTION	QTY
13A	9SM22030	LIFT BALE EXTENSION	2
13B	9SCF000021	1/2-13X1.00HHCS	8
	9SE106A-5	LOCKWASHER	8
	9SCF000027	1/2-13HN	8
14A	9SL13981	LIFT BALE WELDED ASBLY	1
14B	9SS8025-91	SELF TAPPING SCREW	4
15A	9SS28082	FOOT	4
15B	9SS9225-68	THREAD FORMING SCREW (CUTTING)	4
16	9SG6548	NAMEPLATE	1
17	9SG6548	NAMEPLATE	1

Base, Plenum Sides & Lift Bale Assembly

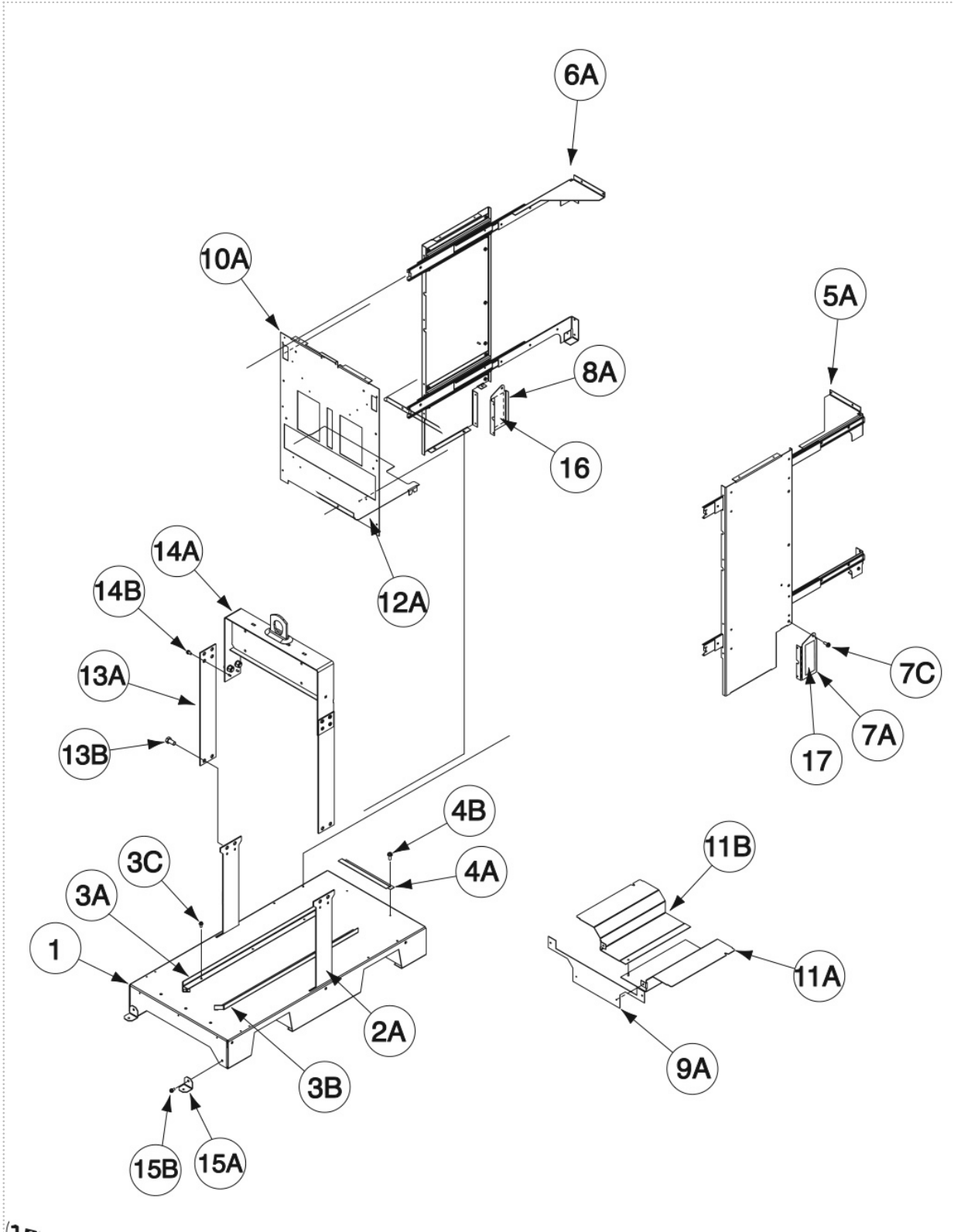

P-612-F.jpg

Rectifier & Heatsink Assembly

KEY	PART NUMBER	DESCRIPTION	QTY
1A	9SL13983	CENTER DIVIDER	1
	9SS8025-92	SELF TAPPING SCREW	7
	9SS9262-27	PLAIN WASHER	4
	9SE106A-1	LOCKWASHER	4
	9SCF000010	#10-24HN	4
2A	9SS16656-4	OUTPUT TERMINAL ASBLY	6
2B	9SCF000371	#10-24X.50HHCS-FULL-GR2-3147	12
	9SG6506	Transformer & Rectifier Asbly	1
5A	9SG6508	RECTIFIER REFERENCE ASBLY	1
5B	9SS18504-9	CURRENT TRANSDUCER	1
5C	9SS9225-36	THREAD FORMING SCREW (CUTTING)	2
	9SCF000015	1/4-20X1.00HHCS	2
	9SS9262-98	PLAIN WASHER	2
	9SE106A-2	LOCKWASHER	2
6	9SG6507	TRANSFORMER ASBLY	1
8A	9SS10404-118	RESISTOR-WW300W3010%	2
8B	9SS28013	RESISTOR BRACKET	2
8C	9SS19742-1	CENTERING WASHER	4
8D	9ST9781-126	THRU BOLT	2
	9SS9262-27	PLAIN WASHER	4
8F	9SE106A-1	LOCKWASHER	2
8G	9SCF000010	#10-24HN	4
8H	9SCF000013	1/4-20X.625HHCS	2
8J	9SE106A-2	LOCKWASHER	2
9A	9SS9262-98	PLAIN WASHER	2
9B	9SE106A-2	LOCKWASHER	2
9C	9SCF000013	1/4-20X.625HHCS	2
	9SS9225-68	THREAD FORMING SCREW (CUTTING)	4
15A	9SS27982	BUS BAR	1
15B	9SCF000030	1/2-13X1.25HHCS	1
15C	9SS9262-1	PLAIN WASHER	2
	9SE106A-15	LOCKWASHER	3
	9SCF000027	1/2-13HN	3
16A	9SM22190	Bus Bar Assembly	1

Rectifier & Heatsink Assembly

KEY	PART NUMBER	DESCRIPTION	QTY
	9SM22091	OUTPUT RECTIFIER - BUS BAR	1
	9SM22092	OUTPUT RECTIFIER - BUS BAR	1
	9SS9262-1	PLAIN WASHER	4
	9SE106A-15	LOCKWASHER	4
	9SCF000027	1/2-13HN	4
16E	9SCF000105	3/8-16X1.25HHCS	2
	9SS9262-4	PLAIN WASHER	2
	9SE106A-16	LOCKWASHER	2
	9SCF000067	3/8-16HN	2
18	9SG6504	Switch Board Assembly	1
18A	9SG6505	HEATSINK (SWITCH BOARD)	1
	9SS24360-1	THERMOSTAT & HOLDER ASBLY	1
	9SS8025-113	SELF TAPPING SCREW	2
20A	9SL15058	CAPACITOR BRACKET	1
	9SCF000013	1/4-20X.625HHCS	2
	9SS9262-98	PLAIN WASHER	2
	9SE106A-2	LOCKWASHER	2
21A	9SM22102	RIGHT SWITCH BOARD BRACKET	1
	9SS25930-5	RX BUTTON HEAD SCREW #10-24X.62	2
	9SE106A-1	LOCKWASHER	2
22	9SM16737	CAPACITOR BRKT	1
23A	9SM22152	SWITCH BOARD CAPACITOR BRACKET	1
23B	9SS8025-91	SELF TAPPING SCREW	4
24A	9SS22168	HEAT SINK HOLDER	2
	9ST11827-44	CARRIAGE BOLT	2
24C	9SE106A-2	LOCKWASHER	2
24D	9SCF000017	1/4-20HN	2
25	9SS13490-219	CAPACITOR	2
26A	9SG4795-2	SWITCH PC BD ASBLY	1
	9SS25930-6	TORX BUTTON HEAD SCREW 1/4-20X.62	12
	9SE106A-2	LOCKWASHER	12
27A	9SS28073	CAPACITOR EXTENSION	4
27B	9ST14731-69	M5 X .8 X 30 HHCS	4
	9SS9262-27	PLAIN WASHER	4

Rectifier & Heatsink Assembly

KEY	PART NUMBER	DESCRIPTION	QTY
	9SE106A-1	LOCKWASHER	4
28A	9SCF000013	1/4-20X.625HHCS	4
28B	9SE106A-2	LOCKWASHER	4
	9SS9262-98	PLAIN WASHER	4
	9SS9225-68	THREAD FORMING SCREW (CUTTING)	4
	9SCF000069	1/4-20X1.25HHCS	4
	9ST14605	INSULATOR	4
	9ST11267-B	INSULATOR	8
	9SS9262-98	PLAIN WASHER	4
	9SE106A-2	LOCKWASHER	4
	9SCF000017	1/4-20HN	4
30	9SS18444-10	CURRENT TRANSFORMER	2
34	9SS24700-9	CONNECTORSEALEDRECEPTACLE	1
35	9SS24700-4	CONNECTORSEALEDRECEPTACLE	1

AC Switch Assembly

KEY	PART NUMBER	DESCRIPTION	QTY
	9SG6423	AC SWITCH ASBLY	1
1A	9SG6543	AC SWITCH SUB-ASBLY	1
	9SS8025-91	SELF TAPPING SCREW	6
3A	9SM22012	AC SWITCH TOP	1
3B	9SS8025-91	SELF TAPPING SCREW	8
	9SG6616	AC Switch Base Assembly	1
5A	9SG6415	AC SWITCH BASE	1
6A	9SM9300-57	BEARING39DOUBLE SHIELD	6
6B	9SCF000062	5/16-18X1.00HHCS	6
6C	9SS9262-121	PLAIN WASHER	6
	9SE106A-4	LOCKWASHER	6
	9SCF000029	5/16-18HN	6
7A	9SM22009	LEFT OUTPUT STUD BRACKET	1
7B	9SS8025-91	SELF TAPPING SCREW	3
7C	9SS16656-4	OUTPUT TERMINAL ASBLY	2
	9SCF000371	#10-24X.50HHCS-FULL-GR2-3147	4
8A	9SM22010	RIGHT OUTPUT STUD BRACKET	1
8B	9SS8025-91	SELF TAPPING SCREW	3
8C	9SS16656-4	OUTPUT TERMINAL ASBLY	2
8D	9SCF000371	#10-24X.50HHCS-FULL-GR2-3147	4
9A	9SL12218-1	CHOKE ASBLY	1
9B	9SS9225-91	THREAD FORMING SCREW	4
10	9SS28034	OUTPUT STUD JUMPER	2
11A	9SCF000030	1/2-13X1.25HHCS	4
11B	9SE106A-15	LOCKWASHER	4
11C	9SS9262-1	PLAIN WASHER	4
12A	9SS25304-6	NOISE SUPPRESSOR ASBLY	1
12B	9SS28094	SUPPRESSOR BRACKET	1
12C	9SS8025-91	SELF TAPPING SCREW	2
	9SS9262-27	PLAIN WASHER	1
	9SE106A-1	LOCKWASHER	1
	9SCF000010	#10-24HN	1
13A	9SS18858-5	SUPPRESSOR ASBLY	2
	9SS8025-91	SELF TAPPING SCREW	2

AC Switch Assembly

KEY	PART NUMBER	DESCRIPTION	QTY
	9SS9262-27	PLAIN WASHER	2
	9SE106A-1	LOCKWASHER	2
	9SCF000010	#10-24HN	2
	9SS28076	AC SWITCH DISCONNECT DECAL	1
15A	9SS29483	BRACKET TERMINAL SUPPORT	2
	9SS8025-91	SELF TAPPING SCREW	4
	9SS26124	GROUND REFERENCE	1
17B	9SCF000010	#10-24HN	1
	9SE106A-1	LOCKWASHER	1
	9SS9225-68	THREAD FORMING SCREW (CUTTING)	3

AC Switch Assembly

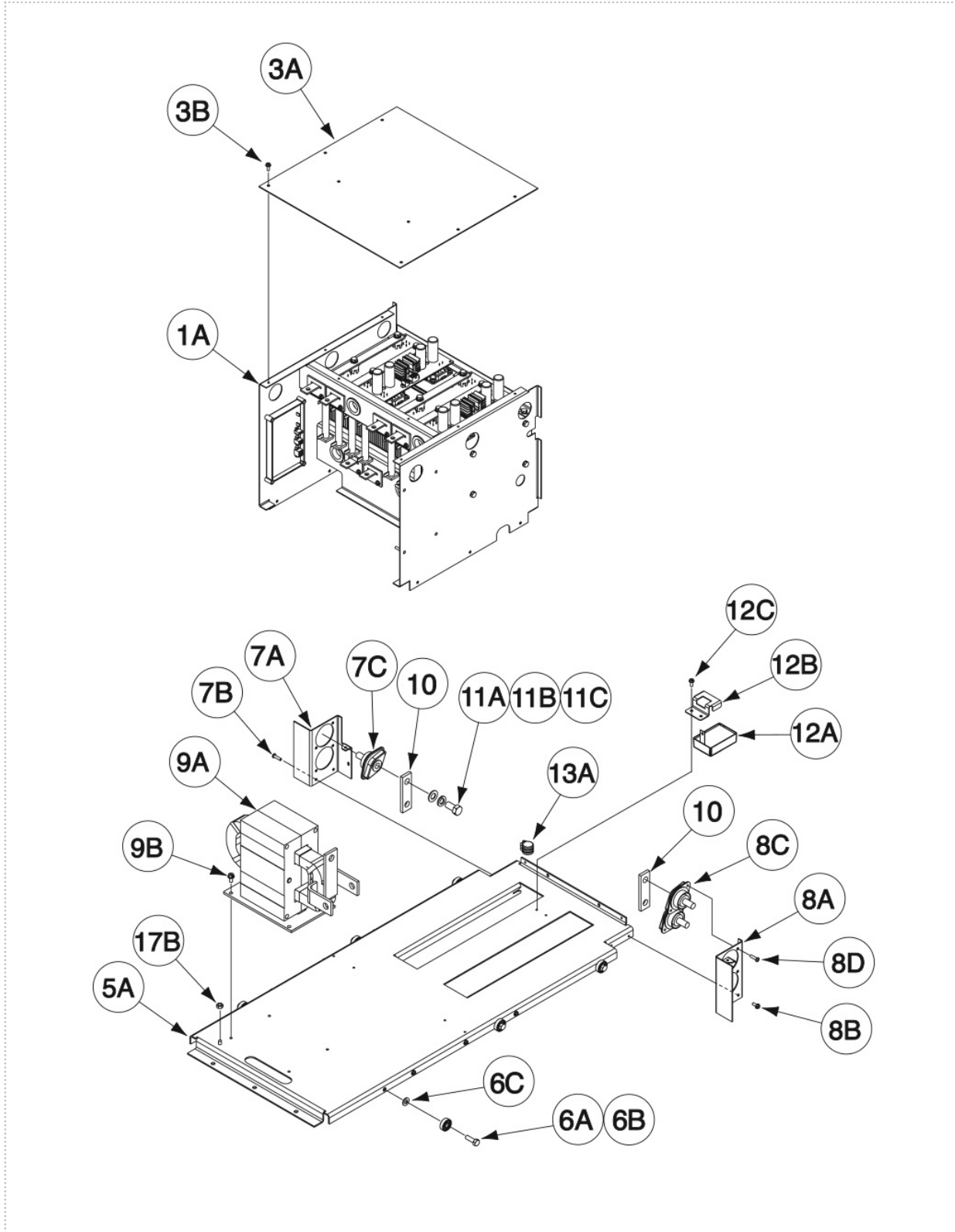

P-612-H.jpg

Printed 12/21/2015 at 12:38:57. Produced by Enigma.

AC Switch Sub Assembly

KEY	PART NUMBER	DESCRIPTION	QTY
	9SG6543	AC SWITCH SUB-ASBLY	1
1	9SG6534	DOUBLE SIDED HEATSINK	1
2A	9SL13975	AC SWITCH PANEL (LEFT SIDE)	1
	9SE106A-2	LOCKWASHER	4
	9SCF000012	1/4-20X.50HHCS	4
3A	9SL13976	AC SWITCH PANEL (RIGHT SIDE)	1
3B	9SE106A-2	LOCKWASHER	4
3C	9SCF000012	1/4-20X.50HHCS	4
4A	9SM17192-39	THERMOSTAT REWORK	4
4B	9SS24916	THERMOSTAT HOLDER	4
4C	9SS8025-62	SELF TAPPING SCREW	16
5A	9SG4798-1	AC SWITCH PC BD ASBLY	4
5B	9SE106A-1	LOCKWASHER	48
5C	9SS25930-5	RX BUTTON HEAD SCREW #10-24X.62	48
6A	9SM22011	AC SWITCH BRACKET	2
6B	9SE106A-2	LOCKWASHER	6
6C	9SCF000012	1/4-20X.50HHCS	6
	9SM22211	Top Switch Bracket Assembly	1
7A	9SL15085	AC SWITCH BRACKET	1
7B	9SS14585-2	LEAD INSULATING PANEL	4
7C	9SS8025-91	SELF TAPPING SCREW	8
7D	9ST12380-8	BUSHING	2
7E	9SS10404-119	RESISTOR-WW50W	8
7F	9SCF000045	#10-24X5.00RHS	8
7G	9ST4479-A	INSULATING WASHER	16
7H	9SS9262-27	PLAIN WASHER	8
7J	9SE106A-1	LOCKWASHER	8
7L	9SE106A-2	LOCKWASHER	3
7M	9SCF000012	1/4-20X.50HHCS	3
	9SM22210	Bottom Switch Bracket Assembly	1
8A	9SM22025	AC SWITCH LOWER BRACKET	1
8B	9SS14585-2	LEAD INSULATING PANEL	4
8C	9SS8025-91	SELF TAPPING SCREW	8
8D	9ST12380-8	BUSHING	2

AC Switch Sub Assembly

KEY	PART NUMBER	DESCRIPTION	QTY
	9SE106A-2	LOCKWASHER	3
	9SCF000012	1/4-20X.50HHCS	3
9A	9SS28025	BUS BAR	4
9B	9SE106A-2	LOCKWASHER	8
9C	9SCF000014	1/4-20X.75HHCS	8
10A	9SS28032	BUS BAR	4
	9SE106A-2	LOCKWASHER	8
	9SCF000014	1/4-20X.75HHCS	8
12A	9SM22095-2	SNUBBER PC BD ASBLY	2
12B	9ST9187-13	#10-24HLN-1817/1-NYLON INSERT	8

AC Switch Sub Assembly

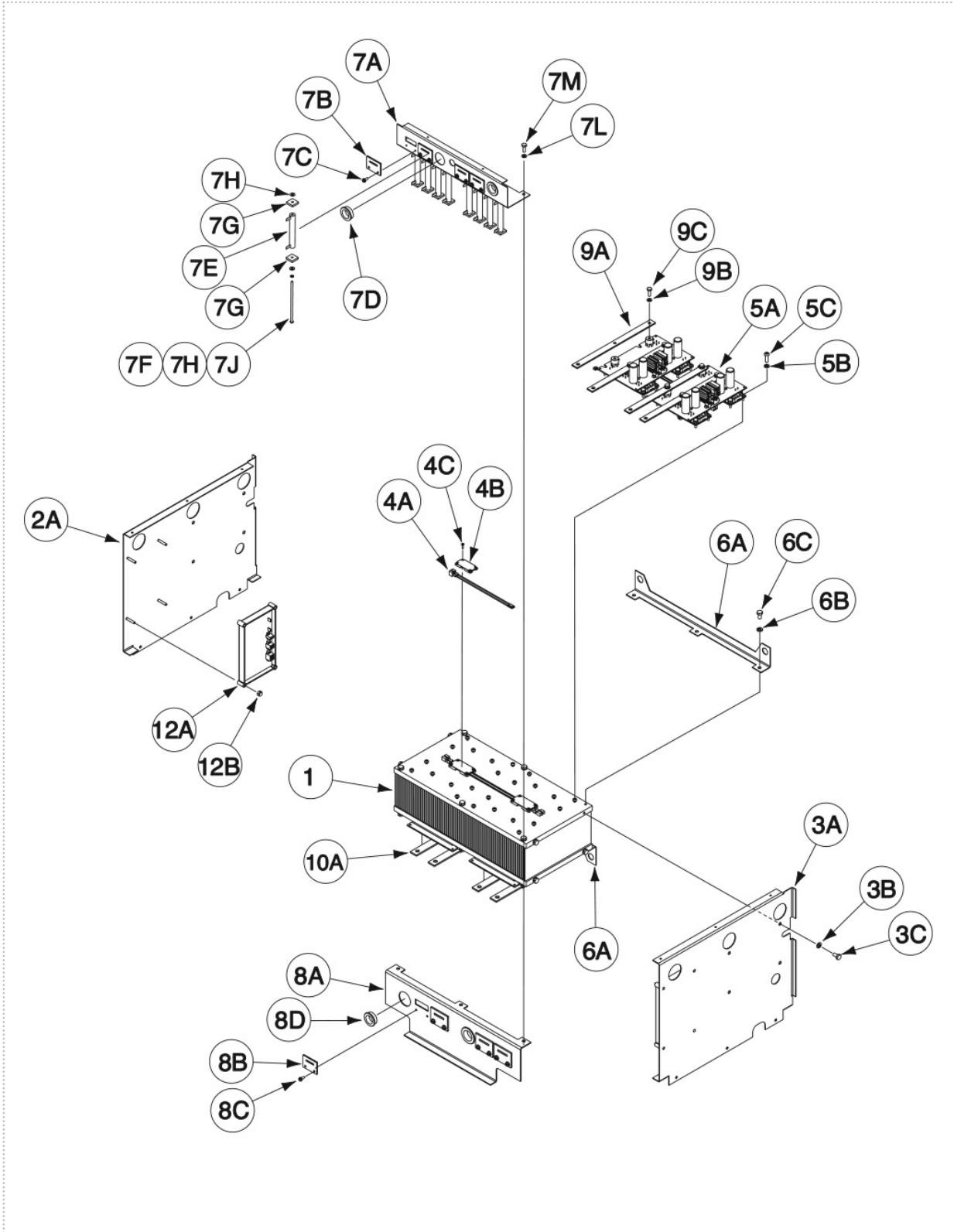

P-612-J.jpg

Auxiliary Transformers & Harmonic Filter

KEY	PART NUMBER	DESCRIPTION	QTY
1A	9SG6417	TOP DIVIDER PANEL	1
1B	9SS8025-91	SELF TAPPING SCREW	8
1C	9ST12380-8	BUSHING	3
1D	9ST12380-4	BUSHING	2
1E	9ST12380-12	BUSHING	1
5A	9SL11566-5	HARMONIC FILTER - PW AC/DC 1000	1
5B	9SS9225-68	THREAD FORMING SCREW (CUTTING)	2
5C	9SS9262-98	PLAIN WASHER	2
5D	9SE106A-2	LOCKWASHER	2
5E	9SCF000017	1/4-20HN	2
6A	9SL10030-6	TRANSFORMER ASBLY	2
	9SS9225-89	THREAD FORMING SCREW	2
	9SS9262-98	PLAIN WASHER	4
	9SE106A-2	LOCKWASHER	4
	9SCF000017	1/4-20HN	4
7A	9SL10033-11	AUX TRANSFORMER ASBLY	1
7B	9SS9225-89	THREAD FORMING SCREW	1
7C	9SS9262-98	PLAIN WASHER	2
7D	9SE106A-2	LOCKWASHER	2
7E	9SCF000017	1/4-20HN	2

Auxiliary Transformers & Harmonic Filter

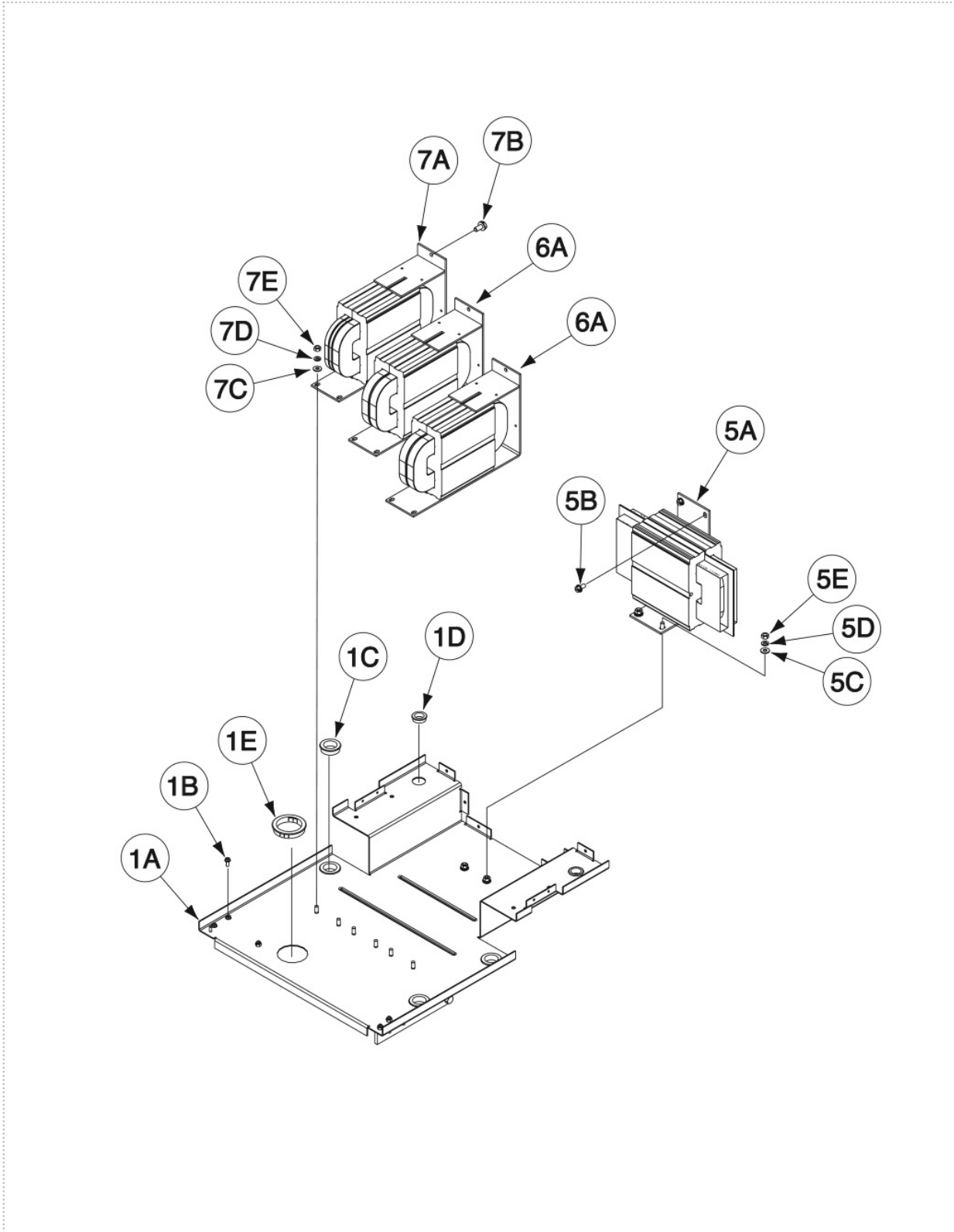

P-612-K.jpg

Covers Assembly

KEY	PART NUMBER	DESCRIPTION	QTY
1A	9SG6418	POWER SOURCE LEFT CASE SIDE	1
1B	9SS24739-5	1/4-20 STAINLESS STEEL SCREW	6
	9ST10097-5	SPEED GRIP NUT RETAINER	1
2A	9SL13993	LEFT SWITCH CASE SIDE	1
	9SS9225-68	THREAD FORMING SCREW (CUTTING)	3
3A	9SG6419	POWER SOURCE RIGHT CASE SIDE	1
	9SS24739-5	1/4-20 STAINLESS STEEL SCREW	6
	9ST10097-5	SPEED GRIP NUT RETAINER	1
4A	9SL13994	RIGHT SWITCH CASE SIDE	1
	9SS9225-68	THREAD FORMING SCREW (CUTTING)	3
5A	9SM22021	INPUT POWER DOOR	1
5B	9SS24739-5	1/4-20 STAINLESS STEEL SCREW	2
8A	9SS27976	IMPELLER DOOR CONNECTOR	4
8B	9SS8025-91	SELF TAPPING SCREW	8
8C	9SS9225-68	THREAD FORMING SCREW (CUTTING)	4
10A	9SM22027	ROOF	1
10B	9SS24739-5	1/4-20 STAINLESS STEEL SCREW	10
10C	9SS12934	COVER SEAL	1
15	9SS22127-2	DECAL-WARRANTY	1
16	9SG6541	PRINT OF G6541 WIRING DIAGRAM	1
17	9SL8064-1	WARNING DECAL (INTERNATIONAL)	1
18	9SG6542	PRINT OF G6542 WIRING DIAGRAM	1
20	9SS27368-6	LOGO DECAL	2
21	9SS28141	POWERWAVE DECAL	2
25	9SS26047	RECONNECT DIAGRAM	1
26	9SS20900	WARNING DECAL	1
27	9ST13086-124	DECAL-STATIC SENSITIVE WARNING	1

Covers Assembly

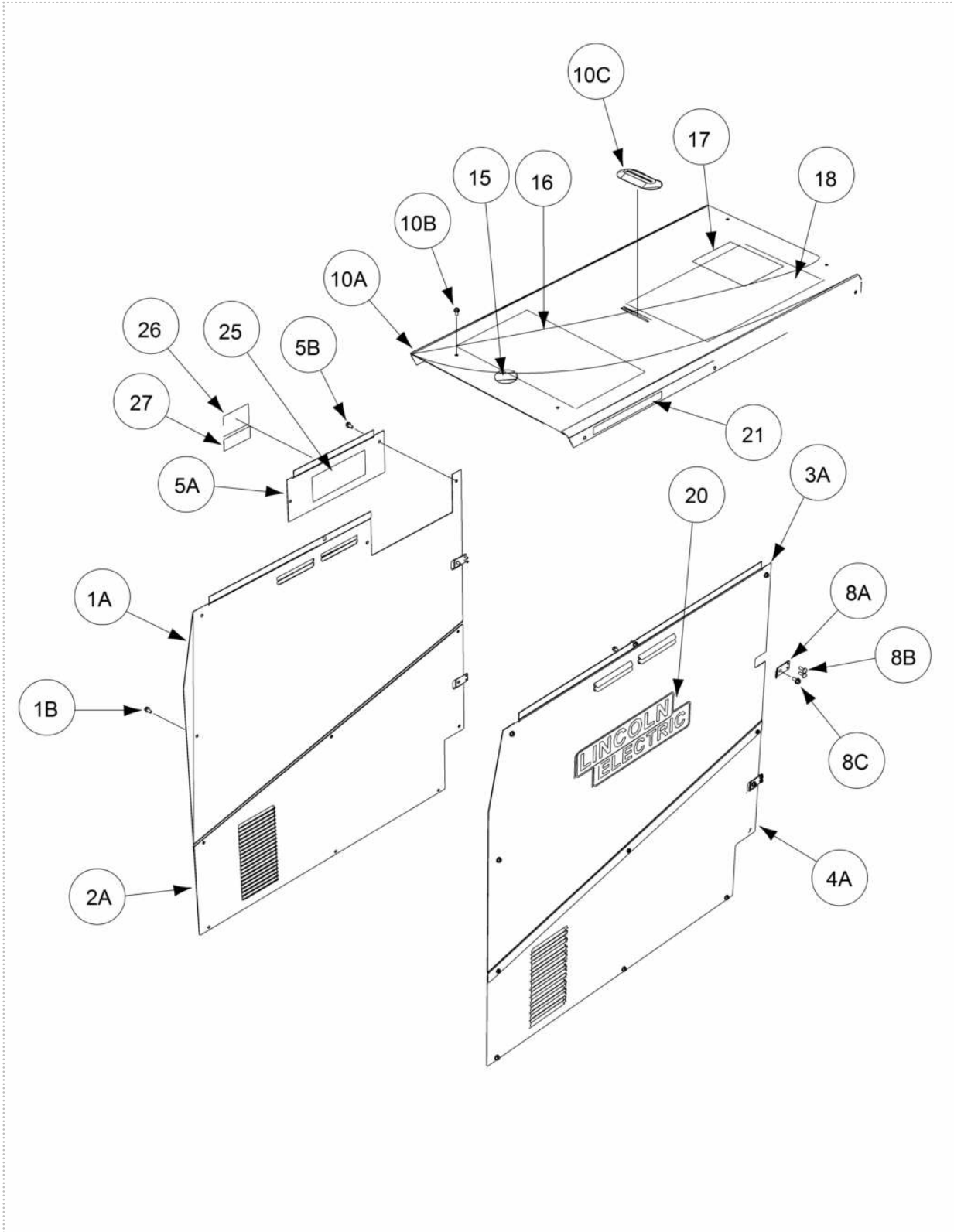

P-612-L.jpg

			
WARNING	<ul style="list-style-type: none"> ● Do not touch electrically live parts or electrode with skin or wet clothing. ● Insulate yourself from work and ground. 	<ul style="list-style-type: none"> ● Keep flammable materials away. 	<ul style="list-style-type: none"> ● Wear eye, ear and body protection.
Spanish AVISO DE PRECAUCION	<ul style="list-style-type: none"> ● No toque las partes o los electrodos bajo carga con la piel o ropa mojada. ● Aíslese del trabajo y de la tierra. 	<ul style="list-style-type: none"> ● Mantenga el material combustible fuera del área de trabajo. 	<ul style="list-style-type: none"> ● Protéjase los ojos, los oídos y el cuerpo.
French ATTENTION	<ul style="list-style-type: none"> ● Ne laissez ni la peau ni des vêtements mouillés entrer en contact avec des pièces sous tension. ● Isolez-vous du travail et de la terre. 	<ul style="list-style-type: none"> ● Gardez à l'écart de tout matériel inflammable. 	<ul style="list-style-type: none"> ● Protégez vos yeux, vos oreilles et votre corps.
German WARNUNG	<ul style="list-style-type: none"> ● Berühren Sie keine stromführenden Teile oder Elektroden mit Ihrem Körper oder feuchter Kleidung! ● Isolieren Sie sich von den Elektroden und dem Erdboden! 	<ul style="list-style-type: none"> ● Entfernen Sie brennbares Material! 	<ul style="list-style-type: none"> ● Tragen Sie Augen-, Ohren- und Körperschutz!
Portuguese ATENÇÃO	<ul style="list-style-type: none"> ● Não toque partes elétricas e electrodos com a pele ou roupa molhada. ● Isole-se da peça e terra. 	<ul style="list-style-type: none"> ● Mantenha inflamáveis bem guardados. 	<ul style="list-style-type: none"> ● Use proteção para a vista, ouvido e corpo.
Japanese 注意事項	<ul style="list-style-type: none"> ● 通電中の電気部品、又は溶材にヒフやぬれた布で触れないこと。 ● 施工物やアースから身体が絶縁されている様にして下さい。 	<ul style="list-style-type: none"> ● 燃えやすいものの側での溶接作業は絶対にしてはなりません。 	<ul style="list-style-type: none"> ● 目、耳及び身体に保護具をして下さい。
Chinese 警告	<ul style="list-style-type: none"> ● 皮肤或湿衣物切勿接触带电部件及焊条。 ● 使你自已与地面和工作件绝缘。 	<ul style="list-style-type: none"> ● 把一切易燃物品移离工作场所。 	<ul style="list-style-type: none"> ● 佩戴眼、耳及身体劳动保护用具。
Korean 위험	<ul style="list-style-type: none"> ● 전도체나 용접봉을 젖은 형갑 또는 피부로 절대 접촉치 마십시오. ● 모재와 접지를 접촉치 마십시오. 	<ul style="list-style-type: none"> ● 인화성 물질을 접근시키지 마십시오. 	<ul style="list-style-type: none"> ● 눈, 귀와 몸에 보호장구를 착용하십시오.
Arabic تحذير	<ul style="list-style-type: none"> ● لا تلمس الاجزاء التي يسري فيها التيار الكهربائي أو الالكترود بجسدك أو بالملابس المبللة بالماء. ● ضع عازلا على جسمك خلال العمل. 	<ul style="list-style-type: none"> ● ضع المواد القابلة للاشتعال في مكان بعيد. 	<ul style="list-style-type: none"> ● ضع أدوات وملابس واقية على عينيك وأذنيك وجسمك.

READ AND UNDERSTAND THE MANUFACTURER'S INSTRUCTION FOR THIS EQUIPMENT AND THE CONSUMABLES TO BE USED AND FOLLOW YOUR EMPLOYER'S SAFETY PRACTICES.

SE RECOMIENDA LEER Y ENTENDER LAS INSTRUCCIONES DEL FABRICANTE PARA EL USO DE ESTE EQUIPO Y LOS CONSUMIBLES QUE VA A UTILIZAR, SIGA LAS MEDIDAS DE SEGURIDAD DE SU SUPERVISOR.

LISEZ ET COMPRENEZ LES INSTRUCTIONS DU FABRICANT EN CE QUI REGARDE CET EQUIPMENT ET LES PRODUITS A ETRE EMPLOYES ET SUIVEZ LES PROCEDURES DE SECURITE DE VOTRE EMPLOYEUR.

LESEN SIE UND BEFOLGEN SIE DIE BETRIEBSANLEITUNG DER ANLAGE UND DEN ELEKTRODENEINSATZ DES HERSTELLERS. DIE UNFALLVERHÜTUNGSVORSCHRIFTEN DES ARBEITGEBERS SIND EBENFALLS ZU BEACHTEN.

			
<ul style="list-style-type: none"> ● Keep your head out of fumes. ● Use ventilation or exhaust to remove fumes from breathing zone. 	<ul style="list-style-type: none"> ● Turn power off before servicing. 	<ul style="list-style-type: none"> ● Do not operate with panel open or guards off. 	WARNING
<ul style="list-style-type: none"> ● Los humos fuera de la zona de respiración. ● Mantenga la cabeza fuera de los humos. Utilice ventilación o aspiración para gases. 	<ul style="list-style-type: none"> ● Desconectar el cable de alimentación de poder de la máquina antes de iniciar cualquier servicio. 	<ul style="list-style-type: none"> ● No operar con panel abierto o guardas quitadas. 	Spanish AVISO DE PRECAUCION
<ul style="list-style-type: none"> ● Gardez la tête à l'écart des fumées. ● Utilisez un ventilateur ou un aspirateur pour ôter les fumées des zones de travail. 	<ul style="list-style-type: none"> ● Débranchez le courant avant l'entretien. 	<ul style="list-style-type: none"> ● N'opérez pas avec les panneaux ouverts ou avec les dispositifs de protection enlevés. 	French ATTENTION
<ul style="list-style-type: none"> ● Vermeiden Sie das Einatmen von Schweißrauch! ● Sorgen Sie für gute Be- und Entlüftung des Arbeitsplatzes! 	<ul style="list-style-type: none"> ● Strom vor Wartungsarbeiten abschalten! (Netzstrom völlig öffnen; Maschine anhalten!) 	<ul style="list-style-type: none"> ● Anlage nie ohne Schutzgehäuse oder Innenschutzverkleidung in Betrieb setzen! 	German WARNUNG
<ul style="list-style-type: none"> ● Mantenha seu rosto da fumaça. ● Use ventilação e exaustão para remover fumo da zona respiratória. 	<ul style="list-style-type: none"> ● Não opere com as tampas removidas. ● Desligue a corrente antes de fazer serviço. ● Não toque as partes elétricas nuas. 	<ul style="list-style-type: none"> ● Mantenha-se afastado das partes moventes. ● Não opere com os painéis abertos ou guardas removidas. 	Portuguese ATENÇÃO
<ul style="list-style-type: none"> ● ヒュームから頭を離すようにして下さい。 ● 換気や排煙に十分留意して下さい。 	<ul style="list-style-type: none"> ● メンテナンス・サービスに取りかかる際には、まず電源スイッチを必ず切して下さい。 	<ul style="list-style-type: none"> ● パネルやカバーを取り外したままで機械操作をしないで下さい。 	Japanese 注意事項
<ul style="list-style-type: none"> ● 頭部遠離煙霧。 ● 在呼吸區使用通風或排風器除煙。 	<ul style="list-style-type: none"> ● 維修前切斷電源。 	<ul style="list-style-type: none"> ● 儀表板打開或沒有安全罩時不準作業。 	Chinese 警告
<ul style="list-style-type: none"> ● 얼굴로부터 용접가스를 멀리하십시오. ● 호흡지역으로부터 용접가스를 제거하기 위해 가스제거기나 통풍기를 사용하십시오. 	<ul style="list-style-type: none"> ● 보수전에 전원을 차단하십시오. 	<ul style="list-style-type: none"> ● 판넬이 열린 상태로 작동치 마십시오. 	Korean 위험
<ul style="list-style-type: none"> ● ابعد رأسك بعيداً عن الدخان. ● استعمل التهوية أو جهاز ضغط الدخان للخارج لكي تبعد الدخان عن المنطقة التي تتنفس فيها. 	<ul style="list-style-type: none"> ● أقطع التيار الكهربائي قبل القيام بأية صيانة. 	<ul style="list-style-type: none"> ● لا تشغيل هذا الجهاز اذا كانت الاغطية الحديدية الواقية ليست عليه. 	Arabic تحذير

LEIA E COMPREENDA AS INSTRUÇÕES DO FABRICANTE PARA ESTE EQUIPAMENTO E AS PARTES DE USO, E SIGA AS PRÁTICAS DE SEGURANÇA DO EMPREGADOR.

使う機械や溶材のメーカーの指示書をよく読み、まず理解して下さい。そして貴社の安全規定に従って下さい。

請詳細閱讀並理解製造廠提供的說明以及應該使用的銀焊材料，並請遵守貴方的有關勞動保護規定。

이 제품에 동봉된 작업지침서를 숙지하시고 귀사의 작업자 안전수칙을 준수하시기 바랍니다.

اقرأ بتمعن وافهم تعليمات المصنع المنتج لهذه المعدات والمواد قبل استعمالها واتبع تعليمات الوقاية لصاحب العمل.

CUSTOMER ASSISTANCE POLICY

The business of The Lincoln Electric Company is manufacturing and selling high quality welding equipment, consumables, and cutting equipment. Our challenge is to meet the needs of our customers and to exceed their expectations. On occasion, purchasers may ask Lincoln Electric for advice or information about their use of our products. We respond to our customers based on the best information in our possession at that time. Lincoln Electric is not in a position to warrant or guarantee such advice, and assumes no liability, with respect to such information or advice. We expressly disclaim any warranty of any kind, including any warranty of fitness for any customer's particular purpose, with respect to such information or advice. As a matter of practical consideration, we also cannot assume any responsibility for updating or correcting any such information or advice once it has been given, nor does the provision of information or advice create, expand or alter any warranty with respect to the sale of our products.

Lincoln Electric is a responsive manufacturer, but the selection and use of specific products sold by Lincoln Electric is solely within the control of, and remains the sole responsibility of the customer. Many variables beyond the control of Lincoln Electric affect the results obtained in applying these types of fabrication methods and service requirements.

Subject to Change – This information is accurate to the best of our knowledge at the time of printing. Please refer to www.lincolnelectric.com for any updated information.



THE LINCOLN ELECTRIC COMPANY

22801 St. Clair Avenue • Cleveland, OH • 44117-1199 • U.S.A.
Phone: +1.216.481.8100 • www.lincolnelectric.com