

OPERATING MANUAL

IM360
Weldanpower W/P250 D10 (Perkins)
& D10 Pro
9188; 9195; 9196; 9197; 9198; 9199;
9366; 9367; 9368; 9468; 9469
April, 1990

WELDANPOWER 250 D10 and WELDANPOWER 250 D10 PRO

This manual covers equipment which is obsolete and no longer in production by The Lincoln Electric Co. Specifications and availability of optional features may have changed.

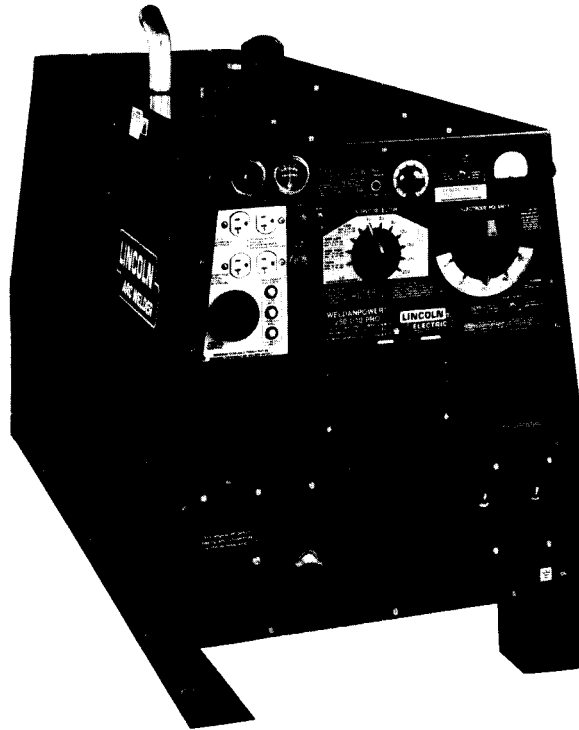

DAMAGE CLAIMS

When this equipment is shipped, title passes to the purchaser upon receipt by the carrier. Consequently, claims for material damaged in shipment must be made by the purchaser against the transportation company at the time the shipment is received.

SAFETY DEPENDS ON YOU

Lincoln arc welding equipment is designed and built with safety in mind. However, your overall safety can be increased by proper installation . . . and thoughtful operation on your part. **DO NOT INSTALL, OPERATE OR REPAIR THIS EQUIPMENT WITHOUT READING THIS OPERATING MANUAL AND THE ARC WELDING SAFETY PRECAUTIONS ON PAGES 2 AND 3.** And, most importantly, think before you act and be careful.

ARC WELDING SAFETY PRECAUTIONS



WARNING: PROTECT YOURSELF AND OTHERS FROM POSSIBLE SERIOUS INJURY OR DEATH.



ELECTRIC SHOCK can kill.

1. a. The electrode and work (or ground) circuits are electrically "hot" when the welder is on. Do not touch these "hot" parts with your bare skin or wet clothing. Wear dry, hole-free gloves to insulate hands.
- b. In semiautomatic or automatic wire welding, the electrode, electrode reel, welding head, nozzle or semiautomatic welding gun are also electrically "hot".
- c. Insulate yourself from work and ground using dry insulation. When welding in damp locations, on metal framework such as floors, gratings or scaffolds, and when in positions such as sitting or lying, make certain the insulation is large enough to cover your full area of physical contact with work and ground.
- d. Always be sure the work cable makes a good electrical connection with the metal being welded. The connection should be as close as possible to the area being welded.
- e. Ground the work or metal to be welded to a good electrical (earth) ground.
- f. Maintain the electrode holder, work clamp, welding cable and welding machine in good, safe operating condition. Replace damaged insulation.
- g. Never dip the electrode in water for cooling.
- h. Never simultaneously touch electrically "hot" parts of electrode holders connected to two welders because voltage between the two can be the total of the open circuit voltage of both welders.
- i. When working above floor level, protect yourself from a fall should you get a shock.
- j. Also see Items 4c and 6.



ARC RAYS can burn.

2. a. Use a shield with the proper filter and cover plates to protect your eyes from sparks and the rays of the arc when welding or observing open arc welding. Headshield and filter lens should conform to ANSI Z87.1 standards.
- b. Use suitable clothing made from durable flame-resistant material to protect your skin and that of your helpers from the arc rays.
- c. Protect other nearby personnel with suitable non-flammable screening and/or warn them not to watch the arc nor expose themselves to the arc rays or to hot spatter or metal.



FUMES AND GASES can be dangerous.

3. a. Welding may produce fumes and gases hazardous to health. Avoid breathing these fumes and gases. When welding, keep your head out of the fume. Use enough ventilation and/or exhaust at the arc to keep fumes and gases away from the breathing zone. When welding on galvanized, lead or cadmium plated steel and other metals which produce toxic fumes, even greater care must be taken.
- b. Do not weld in locations near chlorinated hydrocarbon vapors coming from degreasing, cleaning or spraying operations. The heat and rays of the arc can react with solvent vapors to form phosgene, a highly toxic gas, and other irritating products.
- c. Shielding gases used for arc welding can displace air and cause injury or death. Always use enough ventilation, especially in confined areas, to insure breathing air is safe.
- d. Read and understand the manufacturer's instructions for this equipment and the consumables to be used, including the material safety data sheet (MSDS) and follow your employer's safety practices.
- e. Also see item 7b.



WELDING SPARKS can cause fire or explosion.

4. a. Remove fire hazards from the welding area. If this is not possible, cover them to prevent the welding sparks from starting a fire. Remember that welding sparks and hot materials from welding can easily go through small cracks and openings to adjacent areas. Have a fire extinguisher readily available.
- b. Where compressed gases are to be used at the job site, special precautions should be used to prevent hazardous situations. Refer to "Safety in Welding and Cutting" (ANSI Standard Z49.1) and the operating information for the equipment being used.
- c. When not welding, make certain no part of the electrode circuit is touching the work or ground. Accidental contact can cause overheating and create a fire hazard.
- d. Do not heat, cut or weld tanks, drums or containers until the proper steps have been taken to insure that such procedures will not cause flammable or toxic vapors from substances inside. They can cause an explosion even though they have been "cleaned." For information purchase "Recommended Safe Practices for the Preparation for

Welding and Cutting of Containers and Piping That Have Held Hazardous Substances", AWS F4.1-80 from the American Welding Society (see address below).

- e. Vent hollow castings or containers before heating, cutting or welding. They may explode.
- f. Sparks and spatter are thrown from the welding arc. Wear oil free protective garments such as leather gloves, heavy shirt, cuffless trousers, high shoes and a cap over your hair. Wear ear plugs when welding out of position or in confined places. Always wear safety glasses with side shields when in a welding area.
- g. Connect the work cable to the work as close to the welding area as practical. Work cables connected to the building framework or other locations away from the welding area increase the possibility of the welding current passing through lifting chains, crane cables or other alternate circuits. This can create fire hazards or overheat lifting chains or cables until they fail.
- h. Also see item 7c.

CYLINDER may explode if damaged.

5. a. Use only compressed gas cylinders containing the correct shielding gas for the process used and properly operating regulators designed for the gas and pressure used. All hoses, fittings, etc. should be suitable for the application and maintained in good condition.
- b. Always keep cylinders in an upright position securely chained to an undercarriage or fixed support.
- c. Cylinders should be located:
 - Away from areas where they may be struck or subjected to physical damage.
 - A safe distance from arc welding or cutting operations and any other source of heat, sparks, or flame.
- d. Never allow the electrode, electrode holder, or any other electrically "hot" parts to touch a cylinder.
- e. Keep your head and face away from the cylinder valve outlet when opening the cylinder valve.
- f. Valve protection caps should always be in place and handtight except when the cylinder is in use or connected for use.
- g. Read and follow the instructions on compressed gas cylinders, associated equipment, and CGA publication P-1, "Precautions for Safe Handling of Compressed Gases in Cylinders," available from the Compressed Gas Association, 1235 Jefferson Davis Highway, Arlington, VA 22202.



FOR ELECTRICALLY powered equipment.

6. a. Turn off input power using the disconnect switch at the fuse box before working on the equipment.
- b. Install equipment in accordance with the U.S. National Electrical Code, all local codes and the manufacturer's recommendations.
- c. Ground the equipment in accordance with the U.S. National Electrical Code and the manufacturer's recommendations.



FOR ENGINE powered equipment.

7. a. Turn the engine off before troubleshooting and maintenance work unless the maintenance work requires it to be running.



- b. Operate engines in open, well-ventilated areas or vent the engine exhaust fumes outdoors.



- c. Do not add the fuel near an open flame, welding arc or when the engine is running. Stop the engine and allow it to cool before refueling to prevent spilled fuel from vaporizing on contact with hot engine parts and igniting. Do not spill fuel when filling tank. If fuel is spilled, wipe it up and do not start engine until fumes have been eliminated.



- d. Keep all equipment safety guards, covers and devices in position and in good repair. Keep hands, hair, clothing and tools away from V-belts, gears, fans and all other moving parts when starting, operating or repairing equipment.
- e. In some cases it may be necessary to remove safety guards to perform required maintenance. Remove guards only when necessary and replace them when the maintenance requiring their removal is complete. Always use the greatest care when working near moving parts.
- f. Do not put your hands near the engine fan. Do not attempt to override the governor or idler by pushing on the throttle control rods while the engine is running.
- g. To prevent accidentally starting gasoline engines while turning the engine or welding generator during maintenance work, disconnect the spark plug wires, distributor cap or magneto wire as appropriate.



- h. To avoid scalding, do not remove the radiator pressure cap when the engine is hot.

HAVE ALL INSTALLATION, OPERATION, MAINTENANCE AND REPAIR WORK performed by qualified people.

For more detailed information, it is strongly recommended that you purchase a copy of "Safety in Welding & Cutting — ANSI Standard Z49.1" from the American Welding Society, P.O. Box 351040, Miami, Florida 33135.

INDEX

Arc Welding Safety Precautions	2-3
Specifications	6
General Machine Description	6
Recommended Processes and Equipment	6
AC and DC Constant Current (Manual) Welding	6
Constant Voltage Welding	6
TIG Welding	7
Pipe Thawing	7
Auxiliary Power Supply	7
Engine Specifications	8
Alternator Specifications	8
Welding Output	9
Auxiliary Power Output	9
Optional Features	9
Installation Instructions	10
Safety Precautions	10
Spark Arrestor	10
Location/Ventilation	10
Machine Grounding	10
Undercarriage	10
Installation of Equipment Required for Recommended Processes	11
TIG Welding	11
Standby Power Connections	11-12
Connection of Wire Feeders	12
Connection of the WP 250 D10 to the LN-22/LN-25	12
Connection of the WP 250 D10 to the LN-7 with K240 Contactor Kit	12
Connection of the WP 250 D10 PRO to the LN-22/LN-25	12
Connection of the WP 250 D10 PRO to the LN-7, LN-8, LN-9, or LN-23P	13
Connection diagrams	14-18
Remote Output Control (Optional)	19
Welding Output Cables	19
Pre-Operation Maintenance	19-20
Operating Instructions	21
Safety Precautions	21
Pipe Thawing	21
Location/Ventilation	21
Angle of Operation	21
Additional Safety Precautions	21
Engine Operation	21
Engine Control Function/Operation	21
Idler Control	22
Starting/Shutdown Instructions	23

Welder Operation	23
Duty Cycle	23
Control Function/Operation	24
Procedure Adjustment	24
Constant Current (Manual) Welding	24
Constant Voltage (Semiautomatic) Welding	24
Auxiliary Power	25
Operation of Options/Accessories	25
TIG Welding	25
Break-in Period	25
Maintenance	26
Safety Precautions	26
Routine Maintenance	26
Periodic Maintenance	27
Troubleshooting	27-29
Parts List	30-37
Wiring Diagram	38-39

SPECIFICATIONS

	Weldanpower 250 D10	Weldanpower 250 D10 PRO
Model:	WP 250 D10	WP 250 D10 PRO
Type:	K1335, K1335-1	K1334, K1334-1
Dimensions: inches (mm) H x W x L:	37.38 x 24.75 x 60.18 (949.4 x 628.7 x 1528.6)	37.38 x 24.75 x 60.18 (949.4 x 628.7 x 1528.6)
Net Weight: lbs. (kg)	1060 (480.8)	1100 (499.0)

GENERAL MACHINE DESCRIPTION

The **Weldanpower 250 D10** is a diesel engine driven arc welding power source designed to provide a constant current output rating of 250 amps at 25 volts AC or DC and a constant voltage output rating of 200 amps at 19 volts DC. The auxiliary power rating of 10.0 kW, 115/230 volts, 60 hertz is suitable for temporary, standby, or emergency power following the engine manufacturer's recommended maintenance schedule.

The **Weldanpower 250 D10 PRO** is a diesel engine driven arc welding power source designed to provide a constant current output rating of 250 amps at 25 volts AC or DC and a constant voltage output rating of 250 amps at 30 volts. The auxiliary power rating of 10.0 kW, 115/230 volts, 60 hertz is suitable for temporary, standby, or emergency power following the engine manufacturer's recommended maintenance schedule.

Both units are designed to meet a noise level of 75 dba at 23 feet (7 meters).

RECOMMENDED PROCESSES AND EQUIPMENT

AC and DC Constant Current (Manual) Welding

AC — 35-250 amperes
DC — 35-250 amperes

100% Duty Cycle on all settings.

An Output Selector with 7 positions for C.C. stick welding.

An Output Control for fine current adjustment.

The Weldanpower 250 D10 and Weldanpower 250 D10 PRO can be used with a broad range of AC and DC stick electrodes. See the latest Weldirectory M-210 for the electrodes within the rating of these units.

Constant Voltage Welding

Weldanpower 250 D10

The CV tap permits the Weldanpower 250 D10 to be used with an LN-22 or LN-25 and .068 (1.7 mm) NR-211-MP Innershield® electrode. Because of the range

of voltage and output current available, this is the only Innershield electrode recommended. The CV tap is rated at 200 Amps 19 Volts at a 100% duty cycle. The typical voltage range available at 200 Amps is 15 to 19. At 100 Amps the voltage range is 18 to 22, and at 80 Amps the voltage range is 19 to 22.5. When CV welding, the output control is used for voltage adjustment.

The Weldanpower 250 D10 can also be used with some other wire feeders (such as the LN-7) which draw a small amount of current from the auxiliary power of the unit while welding. The limiting factors in using an LN-7 with the Weldanpower 250 D10 are:

1. Welding current and voltage must be within the rating of the machine.
2. The auxiliary power voltage into the wire feeder must remain above 98 volts while welding. The auxiliary power voltage is determined by a combination of the welding load and the setting of the "Output Control"; the higher the welding load, the higher (closer to 10 on the dial) the "Output Control" must be set.

When using an LN-7 with the Weldanpower 250 D10 the K240 contactor kit is required.

Weldanpower 250 D10 PRO

This unit is equipped with four CV taps that allow constant voltage welding between 40 amps, 15 volts and 250 amps, 30 volts. The duty cycle on all four taps is 100%. The typical output range for each tap is:

Low Tap —	40 amps @ 15 to 19 volts 200 amps @ 9 to 13 volts
Med. Low Tap —	60 amps @ 18 to 24 volts 250 amps @ 10 to 16 volts
Med. High Tap —	80 amps @ 22 to 29 volts 250 amps @ 15 to 23 volts
High Tap —	100 amps @ 27 to 40 volts 250 amps @ 22 to 30 volts

The "Output Control" provides welding voltage adjustment within the CV ranges.

The Weldanpower 250 D10 PRO, with its CV taps, permits it to be used with a broad range of flux cored wire (Innershield and Outershield) electrodes and solid wires for gas metal arc welding.

Some recommended Innershield electrodes in small diameters up to and including $\frac{5}{64}$ " (2.0 mm) are: NR-311, NR-211-MP, NR-203 series, Lincore 33 and 55. $\frac{5}{64}$ " (2.0 mm) NS-3M can be welded in limited applications. Cable length and other conditions can affect the ultimate results of this application.

Recommended Outershield® electrodes are: .045, .052, and 1/16" (1.1, 1.3 and 1.6 mm) Outershield 71, and 1/16" (1.6 mm) Outershield 70.

Some recommended solid wires for gas metal arc welding are: .030, .035, and .045" (0.8, 0.9 and 1.1 mm) L-50 and L-56 Lincolnweld® electrode.

For any electrodes, including the above recommendations, the procedures should be kept within the rating of the machine. For additional electrode information, see Lincoln publications N675, GS-100, GS-210, H333.1, H355.1.

The Woldanpower 250 D10 PRO can be used with the LN-7, LN-22, and LN-25 wire feeders. The LN-8 and LN-9 wire feeders can also be used, but there will be no voltage control available at the wire feeder unless using the K1334CV-1 with Remote Output Control capabilities. The LN-7, LN-8, and LN-9 wire feeders draw a small amount of current from the auxiliary power of the Woldanpower 250 D10 PRO while welding. The limiting factors in using an LN-7, LN-8, or LN-9 with this unit are:



1. Welding current and voltage must be within the rating of the machine.
2. The auxiliary power voltage into the wire feeder must remain above 98 volts while welding. The auxiliary power voltage is determined by a combination of the welding load and the setting of the "Output Control"; the higher the welding load, the higher (closer to 10 on the dial) the "Output Control" must be set.

TIG Welding

The K799 HI-FREQ™ can be used with this machine to provide high frequency arc stabilization and a gas valve for TIG Welding. The 115 volt AC for the K799 can come from either the 115V receptacle on this machine or from another source. To attach the K799 to the top of the engine welder, a specially designed case is provided when "WP3" is added to the K799 sales spec. When TIG welding (GTAW), AC or DC Constant Current modes may be used but the Woldanpower must be derated to a maximum of 200 amps at 100% duty cycle due to insufficient auxiliary power voltage at greater weld amps.

Pipe Thawing

The Woldanpower 250 D10 and Woldanpower 250 D10 PRO may be used for pipe thawing without harm to the welder. Use only the AC output setting for pipe thawing. Do not use the max. tap or the CV tap settings.

 WARNING	
 PIPE THAWING can result in fire or explosion.	<ul style="list-style-type: none">● Only connect welder across FROZEN section of CONTINUOUS METAL PIPE.● While thawing, remove any ground leads connected to frozen pipe.● Turn welder on AFTER cables are connected to pipe. Turn off when done.

IMPORTANT SAFETY NOTE: Although not specifically designed for the work, the output of arc welding machines is sometimes used to thaw frozen water pipes by electrical resistance heating of the pipe metal. Pipe thawing, if not done properly, can result in fire, explosion, damage to wiring which may make it unsafe, damage to pipes, damage to the welder, or other hazards. Do not use a welder to thaw before reviewing Lincoln Bulletin E695.1 (dated June, 1989 or later).

Auxiliary Power Supply

A 10,000 watt AC generator provides auxiliary and emergency power. The 115/230 volt 60 hertz output can:

1. Light 100, 100-watt bulbs.
2. Drive a 2 HP motor (provided it is started under no load).
3. Operate all AC power tools within the rating of the unit.
4. Replace temporary power lines at job sites.

Dependable power — little maintenance. Auxiliary power output has circuit breaker protection.

IMPORTANT SAFETY NOTE: When auxiliary power plants of 5000 watts or larger are used on construction sites, OSHA and the U.S. National Electric Code require the use of a ground fault interrupter or an assured equipment grounding conductor program. Consult the National Electric Code for full details.

NOTE: Output rating in watts is equivalent to volt-amperes at unity power factor. Output voltage within ±10% at all loads up to rated capacity.

Control Panel Weldanpower 250 D10 PRO

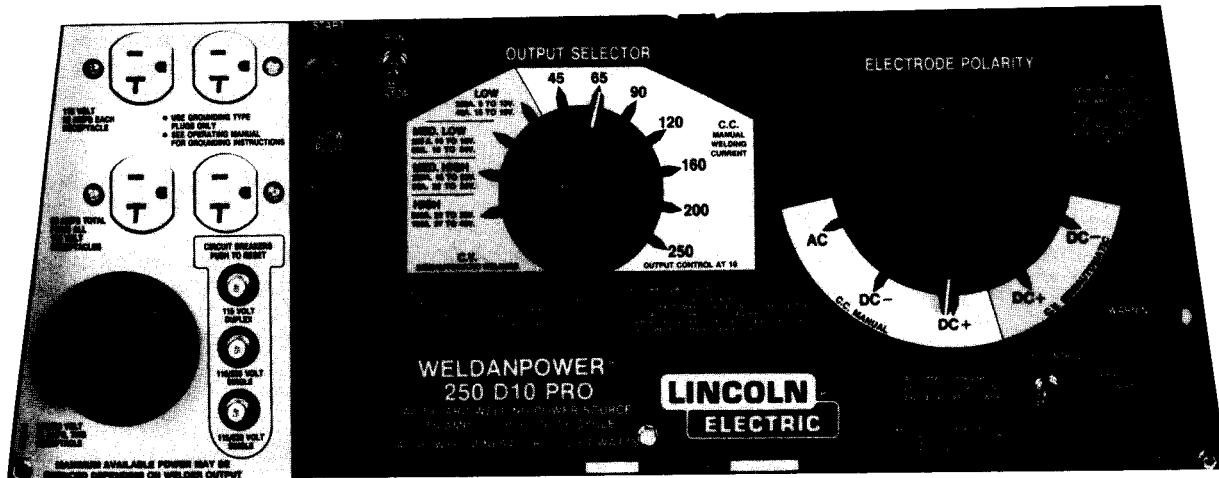

ENGINE SPECIFICATIONS

Make:	Perkins Diesel
Model:	3.09
Cylinders:	3
Cycles:	4
Bore x Stroke, inch (mm):	2.83 x 2.83 (72 x 72)
Displacement, cu. in. (cc):	53.6 (879)
Horsepower (SAEJ1349 Gross):	22.2 at 3600 rpm
Lube Oil Capacity: qts. (L)	3.7 (3.5)
Lubrication:	Forced feed; full flow oil filter
Cooling System:	Water Cooled
Coolant Capacity: qts. (L)	5.4 (5.1)
Fuel System:	Indirect injection; fuel filter with integral fuel shutoff; lift pump
Fuel Capacity: gal. (L)	10 (37.86)
Governor:	Mechanical
Air Cleaner:	Heavy duty two stage dry cartridge type
Starting System:	12 volt battery and starter; push-button start switch; glow plugs; alternator and regulator battery charger; charging ammeter
Engine Idler:	Automatic electronic idler
Muffler:	Low noise muffler
Engine Protection: ⁽¹⁾	Shutdown on high water temperature or low oil pressure
Miscellaneous:	Oil pressure light; water temperature light; fuel level gauge
Operating Speed:	High Idle: 3650 rpm Low idle: 1900 rpm Full load: 3500 rpm
Engine Hour Meter: ⁽²⁾	

⁽¹⁾ High water temperature shutdown standard on all units. Low oil pressure shutdown standard on K1335CV-1, K1334CV, and K1334CV-1 only. Not available on K1335CV.

⁽²⁾ Engine hour meter standard on K1335CV-1, K1334CV, and K1334CV-1. Available as field installed option for K1335CV

ALTERNATOR SPECIFICATIONS

Welder Output	
Constant Current: (WP 250 D10 and WP 250 D10 PRO)	250 Amps AC, 250 Amps DC at 25 Volts 7 Positions on Output Selector rated 45, 65, 90, 120, 160, 200 & 250 Amps Output Control for fine current adjustment Current Range — 35-250 Amps AC 35-250 Amps DC 100% Duty Cycle on all settings Maximum Open Circuit Voltage at 3650 rpm — 80 Volts RMS
Constant Voltage: (WP 250 D10 only)	200 Amps DC at 19 Volts Output Control for voltage adjustment Current & Voltage Range — 200 Amps, 15-19 Volts 80 Amps, 19-22.5 Volts 100% Duty Cycle Maximum Open Circuit Voltage at 3650 rpm — 29 Volts RMS
Constant Voltage: (WP 250 D10 PRO only)	250 Amps DC at 30 Volts 4 Positions on Output Selector Output Control for voltage adjustment Terminal Strip for connection of wire feeders Current and Voltage Range: LOW Tap — 40 Amps at 15 to 19 Volts 200 Amps at 9 to 13 Volts MED. LOW Tap — 60 Amps at 18 to 24 Volts 250 Amps at 10 to 16 Volts MED. HIGH Tap — 80 Amps at 22 to 29 Volts 250 Amps at 15 to 23 Volts HIGH Tap — 100 Amps at 27 to 40 Volts 250 Amps at 22 to 30 Volts See Graphs 1 and 2 for more detailed constant voltage output ranges. 100% Duty Cycle. Maximum Open Circuit Voltage at 3650 rpm — 60 Volts RMS

GRAPH 1
High — Medium Low
Constant Voltage Output Ranges
For Weldanpower 250 D10 PRO

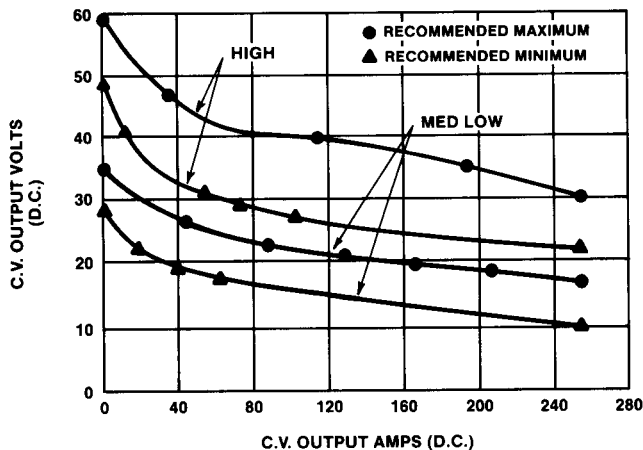

GRAPH 2
Medium High — Low
Constant Voltage Output Ranges
For Weldanpower 250 D10 PRO

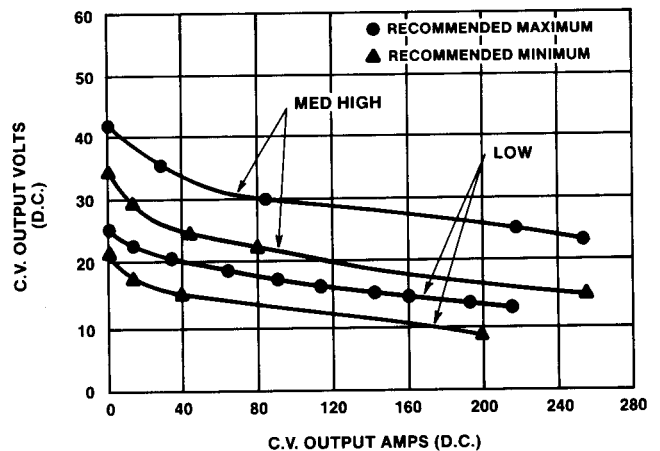

Auxiliary Power Output

10,000 watts of 60 Hertz 115/230 VAC with $\pm 10\%$ voltage regulation.

Suitable for temporary, standby or emergency power using engine manufacturer's recommended maintenance schedule.

115 Volt Circuit: Up to 86 amps can be drawn in combination from two 20 amp duplex grounding receptacles protected by a 40 amp circuit breaker and one 50 amp 115/230 dual voltage receptacle protected by two 45 amp circuit breakers.

230 Volt Circuit: 45 amps can be drawn from a 50 amp 115/230 dual voltage receptacle protected by two 45 amp circuit breakers.

NOTE: Output rating in watts is equivalent to volt-amperes at unity power factor. Output voltage within $\pm 10\%$ at all loads up to rated capacity.

OPTIONAL FEATURES

K802N Power Plug Kit — An auxiliary power plug kit is available factory installed (provides plug for each receptacle).

K799WP3 High Freq — High frequency unit with gas valve for TIG welding. Rated 250 amps. Modified K799 case design which allows for mounting to the Weldanpower 250 D10 or Weldanpower 250 D10 PRO roof.

K768 Undercarriage — For in-plant and yard towing. (For highway use, consult applicable federal, state and local laws regarding possible requirements for brakes, lights, fenders, etc.) Two 4.80 x 12" (122 x 305 mm) four-ply tubeless tires. Bedplate mounting. Has stand for tow bar and grips for hand pulling. Overall width 43.06 inches (1.09 meters).

K702 Accessory Set — Includes 35 feet (10 m) of electrode cable and 30 feet (9 m) of work cable, headshield, work clamp and electrode holder. Cable rated 40% duty cycle at 250 amps.

K855 Engine Hour Meter (Field installed kit for K1335CV only) — A 12 volt hour meter is available to record accumulated engine running hours.

K775 Remote Output Control — Portable control provides same dial range at the output control on the welder from a location up to 25 feet (7.5 m) from the welder. (For use on K1334CV-1 only.)

NOTE: Only one Remote Output Control may be connected to the terminal strip at one time. If a wire feeder or Amptrol Remote Output Control is connected to the terminal strip the K775 cannot be connected.

K843 Amptrol™ Adapter Kit — Used to connect Hand Amptrol™ (K812) or Foot Amptrol™ (K813), Remote Output Control (K775) and Hi-Freq™ (K799WP3) to the welder. (For use on K1334CV-1 only.)

INSTALLATION INSTRUCTIONS

SAFETY PRECAUTIONS

! WARNING

Do not attempt to use this equipment until you have thoroughly read the engine manufacturer's manual supplied with your welder. It includes important safety precautions, detailed engine starting, operating and maintenance instructions, and parts lists.

Spark Arrestor

Some federal, state or local laws may require that diesel engines be equipped with exhaust spark arrestors when they are operated in certain locations where un-arrested sparks may present a fire hazard. The standard muffler included with this welder does not qualify as a spark arrestor. When required by local regulations a suitable spark arrestor must be installed and properly maintained.

CAUTION: An incorrect arrestor may lead to damage of the engine or its performance. Contact the engine manufacturer for specific recommendations.

Location/Ventilation

! WARNING

	<p>ELECTRIC SHOCK can kill.</p> <ul style="list-style-type: none"> Do not touch electrically live parts such as output terminals or internal wiring
	<p>ENGINE EXHAUST can kill.</p> <ul style="list-style-type: none"> Use in open, well ventilated areas or vent exhaust outside
	<p>MOVING PARTS can injure.</p> <ul style="list-style-type: none"> Do not operate with doors open or guards off Stop engine before servicing Keep away from moving parts

Only qualified personnel should install, use, or service this equipment.

Machine Grounding

Because this portable engine driven welder or generator creates its own power, it is not necessary to

connect its frame to an earth ground, unless the machine is connected to premises wiring (your home, shop, etc.).

To prevent dangerous electric shock, other equipment to which this engine driven welder supplies power must:

- be grounded to the frame of the welder using a grounded type plug, or
- be double insulated.

Where this welder is mounted upon a truck or trailer, its frame must be securely connected to the metal frame of the vehicle.

Where this engine driven welder is connected to premises wiring such as that in your home or shop, its frame must be connected to the system earth ground. See further connection instructions in the section entitled Standby Power Connections as well as the article on grounding in the latest National Electrical code.

In general, if the machine is to be grounded, it should be connected with a #6 or larger copper wire to a solid earth ground such as a metal water pipe going into the ground for at least ten feet and having no insulated joints, or to the metal framework of a building which has been effectively grounded. The National Electrical Code lists a number of alternate means of grounding electrical equipment. A machine grounding stud marked with the symbol $\frac{\perp}{\perp}$ is provided on the welder control panel.

Undercarriage

The recommended undercarriage for use with this equipment for in-plant and yard towing by a vehicle⁽¹⁾ is Lincoln's K768. If the user adapts a non-Lincoln undercarriage, he must assume responsibility that the method of attachment and usage does not result in a safety hazard nor damage the welding equipment. Some of the factors to be considered are as follows:

- Design capacity of undercarriage vs. weight of Lincoln equipment and likely additional attachments.
- Proper support of, and attachment to, the base of the welding equipment so there will be no undue stress to the framework.
- Proper placement of the equipment on the undercarriage to insure stability side to side and front to back when being moved and when standing by itself while being operated or serviced.
- Typical conditions of use, i.e., travel speed; roughness of surface on which the undercarriage will be operated; environmental conditions; likely maintenance.

5. Conformance with federal, state and local laws.⁽¹⁾

⁽¹⁾ Consult applicable federal, state and local laws regarding specific requirements for use on public highways.

! WARNING	
	<ul style="list-style-type: none"> • Do not lift this machine using lift bale if it is equipped with a heavy accessory such as trailer or gas cylinder. • Lift only with equipment of adequate lifting capacity. • Be sure machine is stable when lifting.
FALLING EQUIPMENT can cause injury.	

INSTALLATION OF EQUIPMENT REQUIRED FOR RECOMMENDED PROCESSES

TIG Welding

The K799WP3 Hi-Freq Unit includes an R.F. bypass capacitor kit which must be installed for power source protection. Installation instructions are in the kit. (When using the Weldanpower 250 D10 or Welda-power 250 D10 PRO with any other high frequency

equipment, an **R.F. bypass capacitor must be installed.** Order kit T12246.) Also, when using any high frequency equipment with a Welda-power D10 PRO with the remote control option (K1334CV-1) having a code #9195 or lower, the Welda-power must have **kit M16036 installed.** To provide protection the welder grounding stud must be connected to ground. Also follow the grounding instructions given in the Hi-Freq Instruction Manual. The K799WP3 incorporates a case design which allows for mounting to the Welda-power 250 D10 or Welda-power 250 D10 PRO roof.

Standby Power Connections

Suitable for temporary, standby, or emergency power using engine manufacturer's recommended maintenance schedule.

The Welda-power 250 D10 and Welda-power 250 D10 PRO can be permanently installed as a standby power unit for a 230 volt-3 wire, 43 ampere service. Connections must be made by a licensed electrician who can determine how the 115/230 volt Welda-power can be adapted to the particular installation and comply with all applicable electrical codes. The following information can be used as a guide by the electrician for most applications (refer also to the connection diagram shown in Figure 1).

Figure 1
Connection of W/P 250 D10 to Premises System

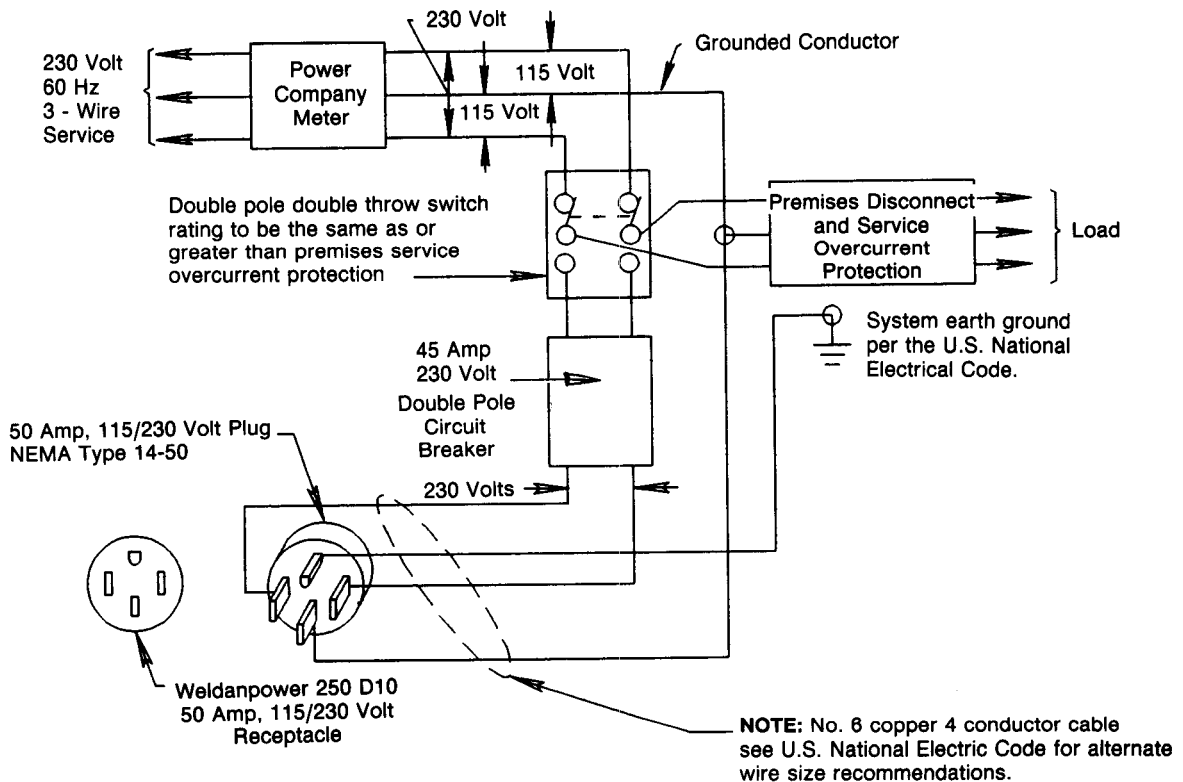

IMPORTANT: When the Weldanpower is connected to a 230 volt, 3-wire line, the unit should be operated with the idler switch in the “High Idle” position to avoid load sensing problems. If the Weldanpower engine is operated at automatic idle, the 230 volt circuit will sense loads and cause the engine to accelerate to high idle. However, only one leg of the 115 volt circuit will sense loads. The idler sensing circuit will **only** sense a load when it is applied to the 115 volt leg (#3 and #5, ground; see wiring diagram) of the Weldanpower which is connected to the 115 volt receptacles on the machine. The idler circuit does not sense the other 115 volt leg (#5, ground; and #6).

1. Install a double pole, double throw switch between the power company meter and the premises disconnect.

Switch rating must be the same as or greater than the customer’s premises disconnect and service overcurrent protection.

2. Take necessary steps to assure load is limited to the capacity of the Weldanpower by installing a 45 amp, 230 volt double pole circuit breaker. Maximum rated load for the 230 volt auxiliary is 45 amperes. Loading above 45 amperes will reduce output voltage below the allowable – 10% of rated voltage which may damage appliances or other motor-driven equipment.
3. Install a 50 amp 115/230 volt plug (NEMA Type 14-50) to the Double Pole Circuit Breaker using No. 6, 4 conductor cable of the desired length. (The 50 amp 115/230 plug is available in the K802N Plug Kit.)
4. Plug this cable into the 50 amp 115/230 volt receptacle on the Weldanpower 250 D10 case front.

Connection of Wire Feeders

WARNING: Shut off engine before making any electrical connections.

Connect Lincoln Electric wire feeders LN-7, LN-8, LN-9, LN-22, LN-23P, and LN-25 per the following instructions and the appropriate connection diagram following this section. All control cable connections on the Weldanpower 250 D10 PRO are made at the terminal strip located on the lower case front under a hinged cover.

Connection of the WP 250 D10 to the LN-22/LN-25

- a. Shut the welder off.
- b. Connect the electrode cable from the LN-22/LN-25 to the electrode terminal of the welder. Connect the work lead to work terminal of the welder.
- c. Position the welder “Electrode Polarity” switch to the desired polarity, either DC(–) or DC(+).
- d. Position the “Output Selector” switch to the CV position.

- e. Place the idler switch in the high idle position. The engine idling device does not function when welding in the CV mode with the WP250 D10.
- f. Attach the single lead from the LN-22/LN-25 control box to the work using the spring clip on the end of the lead. This is only a control lead — it carries no welding current.
- g. Adjust wire feed speed at the LN-22/LN-25 and adjust the welding voltage with the “Output Control” at the welder.

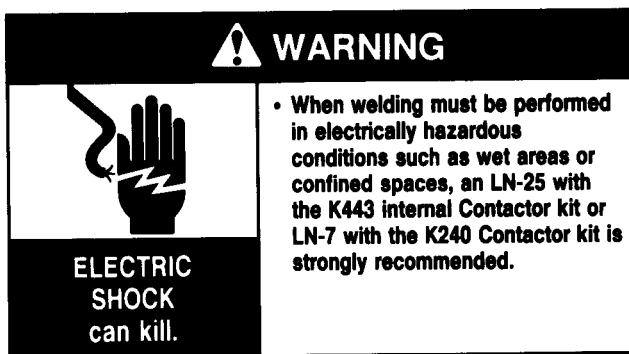

Connection of the WP 250 D10 to the LN-7 with K240 Contactor Kit

- a. Shut the welder off.
- b. Connect the LN-7 and the K240 Contactor Kit per instructions on the appropriate connection diagram.
- c. Place the idler switch in the high idle position. The engine idling device does not function when welding in the CV mode.
- d. Adjust wire feed speed at the LN-7 and adjust the welding voltage with the “Output Control” at the welder.

Connection of the WP 250 D10 PRO to the LN-22/LN-25

- a. Shut the welder off.
- b. Jumper #244 to #4 on the terminal strip. Connect K775 Remote Output Control to the K1334CV-1 WP 250 D10 PRO terminal strip when provided.
- c. Connect the electrode cable from the LN-22/LN-25 to the electrode terminal of the welder. Connect the work cable to the work terminal of the welder.
- d. Position the welder “Electrode Polarity” switch to the desired polarity, either CV DC(–) or DC(+).
- e. Position the “Output Selector” switch to the desired CV position.

f. Attach the single lead from the LN-22/LN-25 control box to the work using the spring clip on the end of the lead. This is only a control lead — it carries no welding current.

g. Place the idler switch in the desired position.⁽¹⁾

In the “High Idle” position, the output contactor will always be closed and the welding electrode will be energized at all times.

In the “Automatic Idle” position, momentarily touch electrode to work to go to high idle. This closes the output contactor and the welding electrode is energized. The output contactor remains closed and the welding electrode remains energized for approximately 10 seconds after welding stops. After this time, the electrode must be momentarily touched to work to close the output contactor.

h. On WP 250 D10 PRO units without “Remote Control” (K1334CV), adjust wire feed speed at the LN-22/LN-25 and adjust the welding voltage with the “Output Control” at the welder. On WP 250 D10 PRO units with “Remote Control” capabilities (K1334CV-1), welding voltage adjustments can be made using a “Remote Output Control” (K775).

NOTE: When using an LN-25 with an optional contactor, place the idler switch in the “High Idle” position. The idler circuit will not function properly with a contactor in the LN-25.

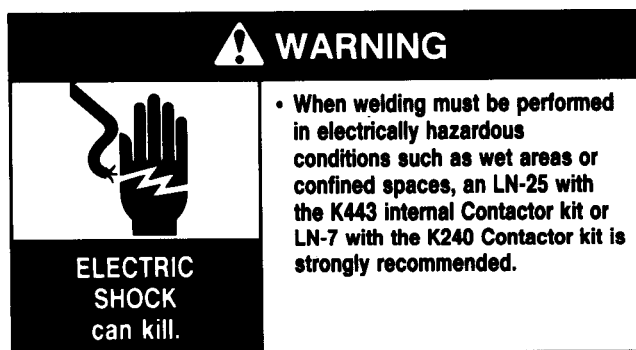

Connection of the WP 250 D10 PRO to the LN-7, LN-8, LN-9, or LN-23P

a. Shut the welder off.

b. Remove jumper #244 to #4 on the terminal strip.

c. Connect the LN-7, LN-8, or LN-23P (with K350 Adapter Kit) per instructions on the appropriate connection diagram. When connecting an LN-8 to a WP 250 D10 PRO without Remote Control (K1334CV), insulate separately leads 75, 76, and 77. There will be no voltage control at the LN-8 wire feeder. On WP 250 D10 PRO units with “Remote Control” capabilities (K1334CV-1), connect leads 75, 76, 77 to the WP 250 D10 PRO terminal strip per instructions on the appropriate connection diagram.

NOTE: Connect the LN-9 to K1334CV-1 Weldanpower 250 D10 Pro units with “Remote Control” capabilities only. See appropriate connection diagram.

d. Position the “Electrode Polarity” switch to the desired polarity, either CV DC(–) or DC(+).

e. Position the “Output Selector” switch to the desired CV position.

f. Place the idler switch in the desired position.⁽¹⁾

In the “High Idle” position, the gun trigger closes and opens the output contactor.

In the “Automatic Idle” position, momentarily touch electrode to work to go to high idle. The gun trigger closes and opens the output contactor when the unit is running at high idle speed.

g. On WP 250 D10 PRO units without “Remote Control” (K1334CV), adjust wire feed speed at the wire feeder and adjust the welding voltage with the “Output Control” at the welder. On WP 250 D10 PRO units with “Remote Control” capabilities (K1334CV-1), welding voltage adjustments can be made at the LN-8 or LN-9 or with a “Remote Output Control” (K775) when using an LN-7.

⁽¹⁾ Refer to “Idler Control” switch section on page 22 for a more detailed description of the idler operation.

CONNECTION OF LN-7 & K240 CONTACTOR KIT WITH 115 VOLT AC AUXILIARY POWER AND CV OUTPUT

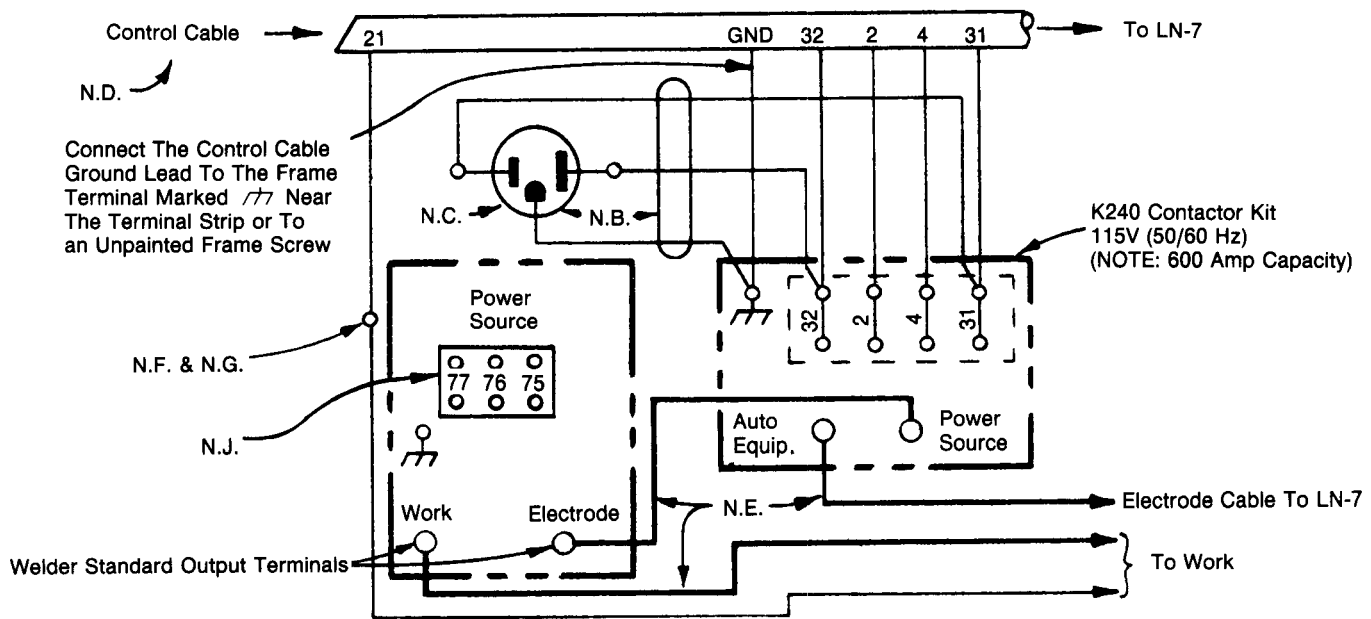

S17742
4-15-88F

WARNING: Turn the power source off when making connections.

CAUTION: Any speed up of the engine RPM by changing the governor setting or over-riding the throttle linkage will cause an increase in the AC auxiliary voltage. If this voltage goes above 140 volts, the LN-7 control circuit will be damaged. The engine governor setting is pre-set at the factory — do not adjust above RPM specifications listed in engine welder Operating Manual.

N.A. Use power source polarity switch to set for desired electrode polarity. Position the output selector switch on the power source to the CV position.

N.B. 3 conductor #16 power cord physically suitable for the installation and plug rated at 115 volts 15 amperes AC.

N.C. Plug into 115 volt AC receptacle on welder control panel or other 115 volt AC supply rated a minimum of 500 volt amperes.

N.D. Leads #21 and GND, do not appear on LN-7's with codes with 7026.

N.E. Welding cables must be of proper capacity for the current and duty cycle of immediate and future applications. See Operator's Manual.

N.F. If LN-7 is equipped with a meter kit, extend lead 21 using #14 or larger insulated wire physically suitable for the installation. An S16586-Length remote voltage sensing work lead may be ordered for this purpose. Connect it directly to the work piece independent of the welding work cable. For convenience, this extended #21 lead should be taped to the welding work lead.

N.G. Tape up bolted connection where lead 21 is extended.

N.H. Idler switch on power source must be in high idle position.

N.J. If an optional remote output control is used, connect it to this terminal strip. **NOTE:** Terminal strip not available on all power sources.

NOTE: This diagram is for reference only. It is not accurate for all machines covered by this manual. The specific diagram for a particular code is pasted inside the machine on one of the enclosure panels. If the diagram is illegible, write to the Service Department for a replacement. Give the welder code number.

CONNECTION OF LN-7 TO WELDANPOWER 250 D10 PRO

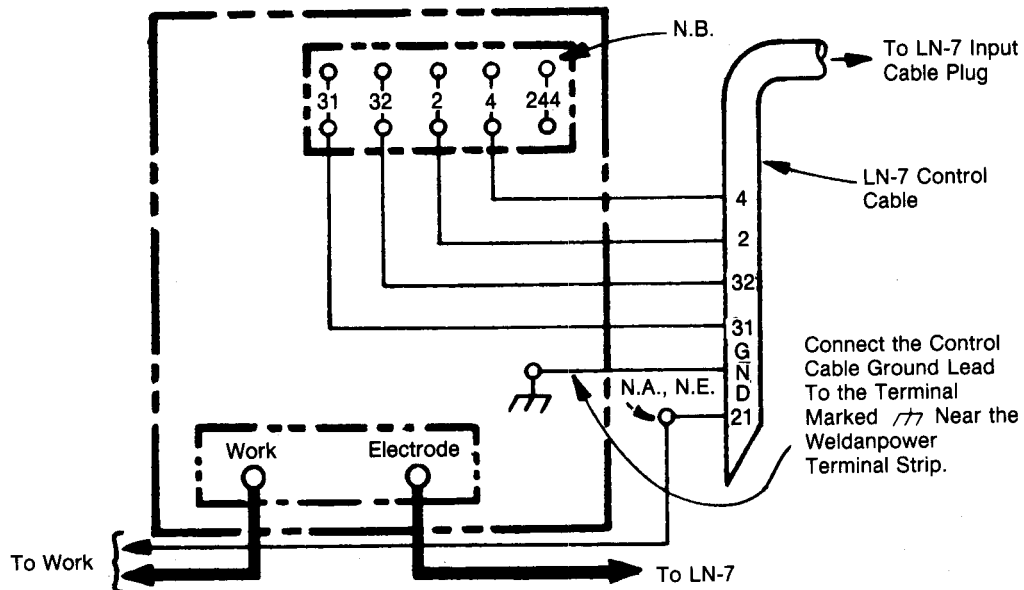

S18304
11-13-87

WARNING: Turn the Weldanpower engine off when making connections.

CAUTION: Any increase of the high idle engine RPM by changing the governor setting or overriding the throttle linkage will cause an increase in the AC auxiliary voltage. If this voltage goes above 140 volts, the LN-7 control circuit will be damaged. The engine governor setting is pre-set at the factory — do not adjust above RPM specifications listed in engine welder Operating Manual.

N.A. For LN-7 equipped with meter kit only: Extend lead 21 using #14 or larger insulated wire physically suitable for the installation. An S16586-Length remote voltage sensing work lead is available for this purpose. Connect it directly to the work piece keeping it electrically separate from the welding work lead circuit and connection. For convenience, this extended #21 lead should be taped to the welding work lead. (This extended #21 lead connection replaces the need to employ the remote work lead accessory on LN-7 meter kits which have a direct work lead jack.

N.B. Remove lead jumper between #4 and #244. No external lead is connected to #244.

N.C. Use Weldanpower polarity switch to set for desired electrode polarity. Position the Output Selector switch on the Weldanpower to a CV position.

N.D. Welding cables must be of proper capacity for the current and duty cycle of immediate and future applications.

N.E. Tape up bolted connection.

NOTE: Leads #21 and GND do not appear on LN-7's with codes below 7026.

NOTE: This diagram is for reference only. It is not accurate for all machines covered by this manual. The specific diagram for a particular code is pasted inside the machine on one of the enclosure panels. If the diagram is illegible, write to the Service Department for a replacement. Give the welder code number.

CONNECTION OF LN-7 TO WELDANPOWER 250 D10 PRO (With Remote Control)

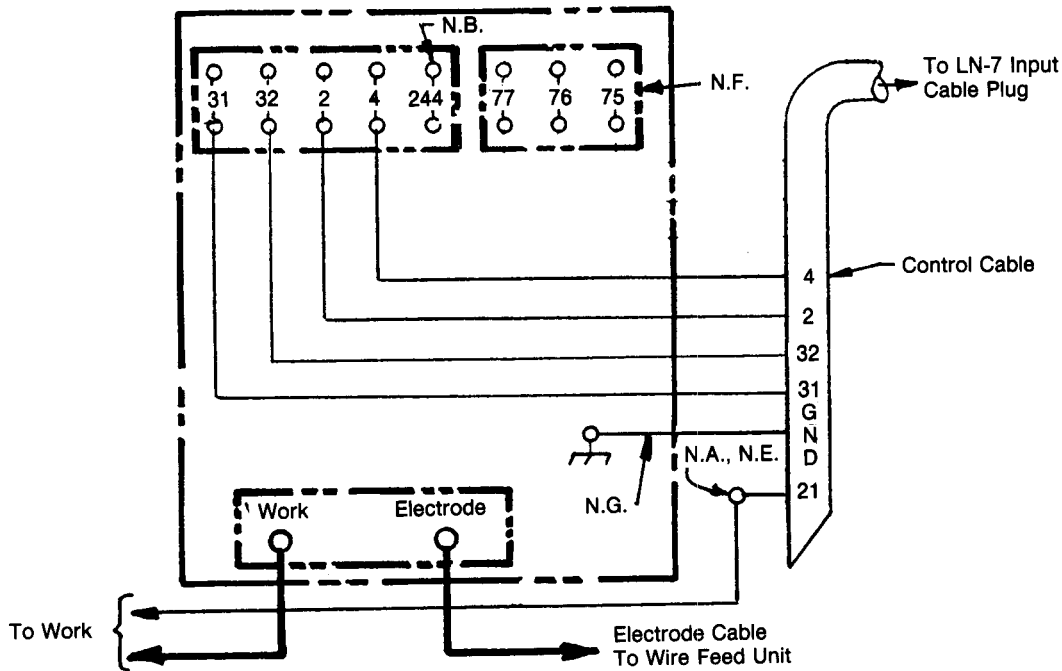

WARNING: Turn the weldanpower engine off when making connections.

S18345
1-8-88

CAUTION: Any increase of the high idle engine RPM by changing the governor setting or overriding the throttle linkage will cause an increase in the AC auxiliary voltage. If this voltage goes above 140 volts, wire feeder control circuits may be damaged. The engine governor setting is pre-set at the factory — do not adjust above RPM specifications listed in engine welder Operating Manual.

N.A. For LN-7 equipped with meter kit only: Extend lead 21 using #14 or larger insulated wire physically suitable for the installation. An S16586-Length remote voltage sensing work lead is available for this purpose. Connect it directly to the work piece keeping it electrically separate from the welding work lead circuit and connection. For convenience, this extended #21 lead should be taped to the welding work lead. (This extended #21 lead connection replaces the need to employ the remote work lead accessory on LN-7 meter kits which have a direct work lead jack.)

N.B. Remove lead jumper between #4 and #244. No external lead is connected to #244.

N.C. Use Wieldanpower polarity switch to set for desired electrode polarity. Position the Output Selector switch on the Wieldanpower to a CV position.

N.D. Welding cables must be of proper capacity for the current and duty cycle of immediate and future applications. See Operating Manual.

N.E. Tape up bolted connection.

N.F. If optional remote output control is used, connect to this terminal.

N.G. Connect the control cable ground lead to the terminal marked $\overline{\text{N}}$ near the Wieldanpower terminal strip.

NOTE: Leads #21 and GND do not appear on LN-7's with codes below 7026.

NOTE: This diagram is for reference only. It is not accurate for all machines covered by this manual. The specific diagram for a particular code is pasted inside the machine on one of the enclosure panels. If the diagram is illegible, write to the Service Department for a replacement. Give the welder code number.

CONNECTION OF LN-8 OR LN-9 TO WELDPANPOWER 250-D10 PRO (With Remote Control)

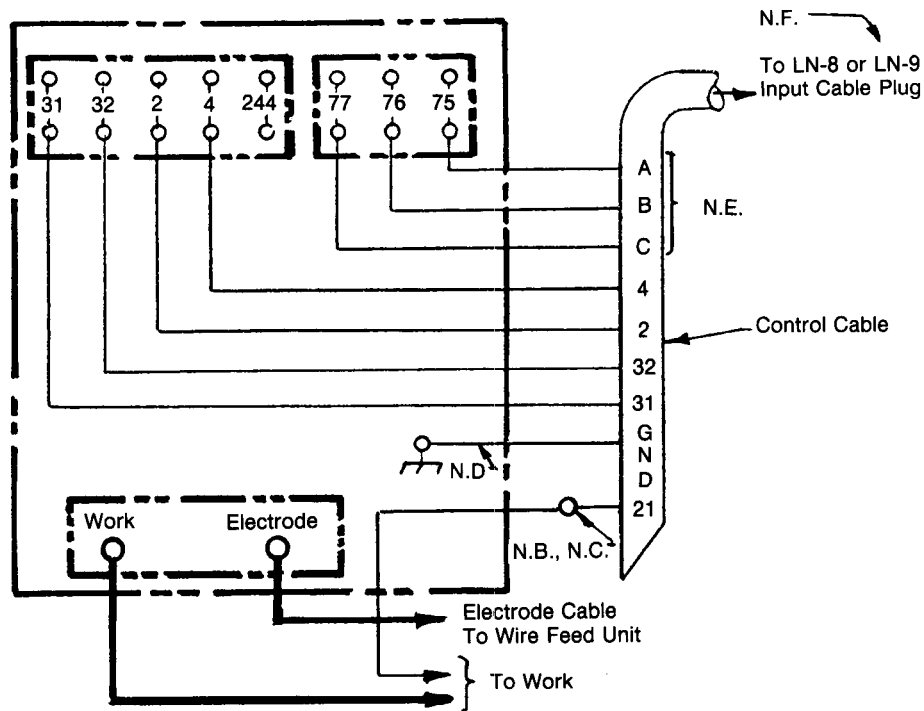

WARNING: Turn the weldanpower engine off when making connections.

S18346
1-8-88

CAUTION: Any increase of the high idle engine RPM by changing the governor setting or overriding the throttle linkage will cause an increase in the AC auxiliary voltage. If this voltage goes above 140 volts, wire feeder control circuits may be damaged. The engine governor setting is pre-set at the factory — do not adjust above RPM specifications listed in engine welder operating manual.

N.A. Welding cable must be of proper capacity for the current and duty cycle of immediate and future applications. See Operating Manual.

N.B. Extend lead 21 using #14 or larger insulated wire physically suitable for the installation. An S16585-Length remote voltage sensing work lead is available for this purpose. Connect it directly to the work piece keeping it electrically separate from the work lead circuit and connection. For convenience, this extended #21 lead should be taped to the welding work lead.

N.C. Tape up bolted connection.

N.D. Connect the LN-8 or LN-9 control cable grounding lead to the frame terminal marked N.D. near the power source terminal strip. The power source must be properly grounded.

N.E. If using an older LN-8 control cable; connect lead #75 to #75 on terminal strip, connect lead #76 to #76 on terminal strip, connect lead #77 to #77 on the terminal strip.

N.F. The LN-9 voltage control jumpers must be connected as follows (refer to LN-9 Operating Manual):

White jumper on Voltage Board to Pin "S".
Blue jumper on Voltage Board (later units only).
or on Start Board (earlier units), to Pin "B".

N.G. Remove lead jumper between #4 and #244. No external lead is connected to #244.

NOTE: This diagram is for reference only. It is not accurate for all machines covered by this manual. The specific diagram for a particular code is pasted inside the machine on one of the enclosure panels. If the diagram is illegible, write to the Service Department for a replacement. Give the welder code number.

LN-23P CONTACTOR VOLTAGE CONTROL OPTION CONNECTED TO WELDANPOWER 250-D10 PRO (With Remote Control)

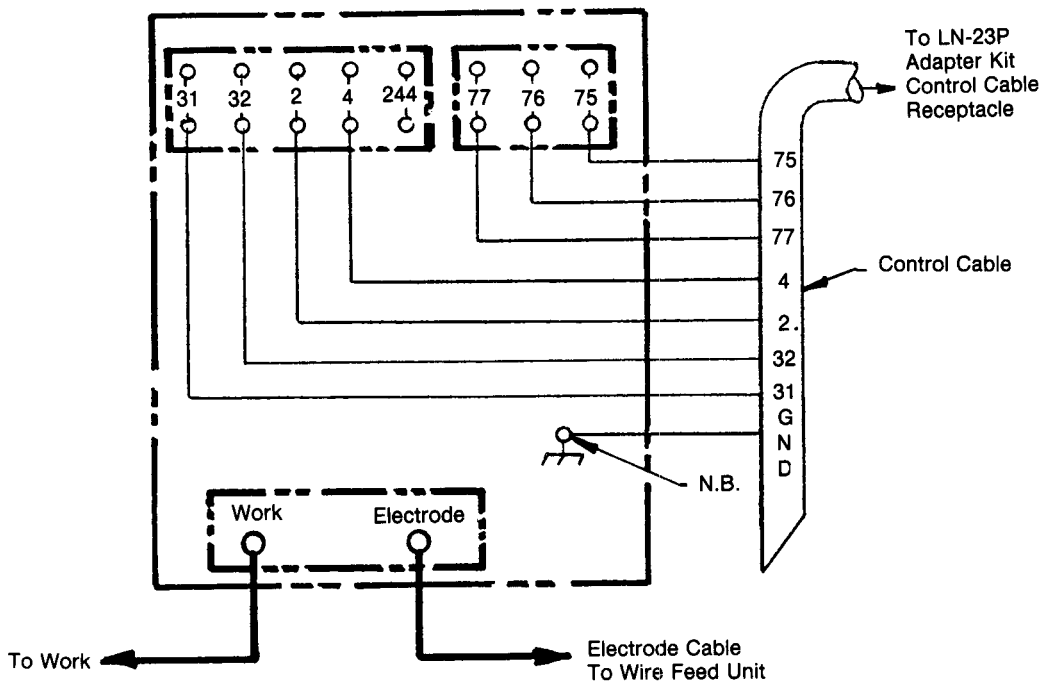

S18347
1-8-88

WARNING: Turn the weldanpower engine off when making connections.

CAUTION: Any increase of the high idle engine RPM by changing the governor setting or overriding the throttle linkage will cause an increase in the AC auxiliary voltage. If this voltage goes above 140 volts, wire feeder control circuits may be damaged. The engine governor setting is pre-set at the factory — do not adjust above RPM specifications listed in engine welder operating manual.

N.A. Welding cable must be of proper capacity for the current and duty cycle of immediate and future applications. See LN-23P Operating Manual for proper sizes.

N.B. Connect the control cable ground lead to the frame terminal marked /// near the power source terminal strip. The power source grounding terminal (marked ⏏ and located near the power source input connections) must be properly connected to electrical ground per the power source operating manual.

N.C. Remove lead jumper between #4 and #244. No external lead is connected to #244.

NOTE: This diagram is for reference only. It is not accurate for all machines covered by this manual. The specific diagram for a particular code is pasted inside the machine on one of the enclosure panels. If the diagram is illegible, write to the Service Department for a replacement. Give the welder code number.

Remote Output Control (Optional)

(For use on K1334CV-1 Weldanpower 250 D10 PRO only.)

WARNING: Shut off welder before making any electrical connections.

NOTE: Output may be controlled remotely using a K775 Remote Output Control, an Amptrol or a wire feeder with output control. Only one form of remote output control may be connected to the terminal strip at any given time.

An optional (K775) "Remote Output Control" is available. The K775 consists of a control box with 25 feet (7.5 m) of four conductor cable. Leads in this cable connect to terminals 75, 76, 77 on the terminal strip and the case grounding screw marked with the symbol ∇ . These terminals are accessible by opening the terminal access cover on the case front. This option will give the same control as the Output Control on the machine.

Foot and Hand Amptrols may also be used with the K1334CV-1 WP 250 D10 PRO and are installed in a similar manner to the K775 Remote Output Control.

A K843 Amptrol Adapter Cable is required for con-

nection of the Amptrol to the screw-type terminals on the welder terminal strip.

IMPORTANT: Extreme caution must be observed when installing or extending the wiring of a remote control. Improper connection of this unit can lead to failure of the output control rheostat or the control circuit. Only the green lead can and should be grounded to the machine case.

When extending the standard remote control, make sure the leads are the same size and the splice is waterproof. Be very careful not to ground the cable when in use and don't let the lugs touch the case.

WELDING OUTPUT CABLES

With the engine off, connect the electrode and work cables to the studs provided. These connections should be checked periodically and tightened if necessary. When welding at a considerable distance from the welder, be sure you use ample size welding cables.

Listed below are copper cable sizes recommended for the rated current and duty cycle. Lengths stipulated are the distance from the welder to work and back to the welder again. Cable sizes are increased for greater lengths primarily for the purpose of minimizing cable drop.

Amps	% Duty Cycle	Cable Sizes for Combined Lengths of Electrode and Work Cables				
		0-50 ft (0-15 m)	50-100 ft (15-30 m)	100-150 ft (30-45 m)	150-200 ft (45-60 m)	200-250 ft (60-75 m)
250	40	2	2	1	1	1/0
250	100	1	1	1	1	1/0

1 AWG Cable = (42.4 mm²), 2 AWG Cable = (33.6 mm²), 1/0 AWG Cable = (53.5 mm²).

PRE-OPERATION MAINTENANCE

Do not start the engine until you perform the following services.

Oil

This engine's crankcase has been filled with 10W-30 oil. Check the dipstick and add oil as needed. (See engine manual for proper grade and viscosity of oil and for break-in information.)

NOTE: Low Oil Pressure Shutdown System will protect engine from sudden loss of oil pressure. It may not protect engine from damage if the engine is run with oil levels below the recommended level. Proper oil level must be maintained. Consult engine operator's manual for proper grade and viscosity of oil.

Engine Coolant

This engine and radiator have been filled with 50% ethylene glycol **low silicate** antifreeze and 50% water. Check the radiator and add a 50-50 solution as needed. (See engine manual or antifreeze container

for alternative antifreeze recommendations.) It is recommended that a low silicate type antifreeze be used for any additions or coolant changes.

CAUTION: High silicate type antifreeze may cause engine damage.

When antifreeze with high silicate levels is used in cooling systems along with supplemental cooling additives, there may develop a point when the solution becomes overconcentrated with silicate. At this point, the excess silicate will separate out and form a gel. This gel will rapidly build in cooling system passages, greatly impairing the heat transferability of the fluid and could potentially cause serious engine damage. You can minimize this problem by using a low silicate antifreeze.

The engine coolant capacity is 5.4 qts. (5.1 L) and was filled with a 50% solution of antifreeze which protects the unit from freezing to -34°F (-37°C). Additional information on antifreeze concentration is shown in Table A.

TABLE A

Ambient Temperature Range	Coolant Concentration	
	Antifreeze	Clean Water
Down to -10°F (-23°C)	25% (1 Part) 1.8 qts (1.7 L) ⁽¹⁾	75% (3 Parts) 3.6 qts (3.4 L)
Down to -34°F (-37°C)	50% (1 Part) 2.7 qts (2.55 L) ⁽¹⁾	50% (1 Part) 2.7 qts (2.55 L)
Freezing to -76°F (-60°C)	66% (2 Parts) 3.8 qts (3.6 L) ⁽¹⁾	34% (1 Part) 1.6 qts (1.5 L)

⁽¹⁾ Required quantities to fill cooling system of a completely drained WP 250

CAUTION: Never exceed a solution greater than 66% antifreeze. The freezing point of concentrations over 66% rises toward zero degrees. A 66% concentration must not be used at temperatures above freezing.

It is best to use the minimum concentration of anti-freeze (25%) when freezing protection is not required. This mixture results in the best heat transfer from the engine to the coolant and provides a corrosion inhibitor.

It is recommended that the coolant be premixed to the desired ratio prior to filling the cooling system.

WARNING

HOT
COOLANT can
burn skin.

- Do not remove cap if radiator is hot.

Fuel

Fill the fuel tank with the grade of diesel fuel recommended in the Engine Operator's Manual. Make sure fuel valve on the fuel filter is in the open position. (With the handle vertical, the fuel valve is open.)

WARNING

GASOLINE fuel
can cause fire or
explosion.

- Stop engine when fueling.
- Do not smoke when fueling.
- Remove cap slowly to release pressure.
- Do not overfill tank.
- Wipe up spilled fuel and allow fumes to clear before starting engine.
- Keep sparks and flame away from tank.
- Shut fuel off at tank when moving machine.

Battery

Remove the insulating cap from the negative battery terminal. Replace and tighten negative battery cable terminal.

NOTE: This machine is furnished with a wet charged battery; if unused for several months, the battery may require a booster charge. Be careful to charge the battery with the correct polarity.

WARNING

GASES
FROM
BATTERY
can
explode.

- Keep sparks, flame and cigarettes away from battery.
- To prevent EXPLOSION when:
 - INSTALLING A NEW BATTERY — disconnect negative cable from old battery first and connect to new battery last.
 - CONNECTING A BATTERY CHARGER — remove battery from welder by disconnecting negative cable first, then positive cable and battery clamp. When reinstalling, connect negative cable last. Keep well ventilated.
 - USING A BOOSTER — connect positive lead to battery first then connect negative lead to copper strap on engine foot.

BATTERY
ACID can
burn eyes
and skin.

- Wear gloves and eye protection and be careful when working near battery.
- Follow instructions printed on battery.

IMPORTANT: To prevent ELECTRICAL DAMAGE WHEN:

- a. Installing a new battery.
- b. Using a booster.

Use correct polarity — **Negative Ground.**



To prevent BATTERY DISCHARGE, if you have an ignition switch, turn it off when engine is not running.

To prevent BATTERY BUCKLING, tighten nuts on battery until snug.

OPERATING INSTRUCTIONS

SAFETY PRECAUTIONS

Pipe Thawing

 WARNING	
	<ul style="list-style-type: none">• Only connect welder across FROZEN section of CONTINUOUS METAL PIPE.• While thawing, remove any ground leads connected to frozen pipe.• Turn welder on AFTER cables are connected to pipe. Turn off when done.
	<p>PIPE THAWING can result in fire or explosion.</p>

IMPORTANT SAFETY NOTE: Although not specifically designed for the work, the output of arc welding machines is sometimes used to thaw frozen water pipes by electrical resistance heating of the pipe metal. Pipe thawing, if not done properly, can result in fire, explosion, damage to wiring which may make it unsafe, damage to pipes, damage to the welder, or other hazards. **Do not use a welder to thaw before reviewing Lincoln Bulletin E695.1 (dated June, 1989 or later).**

Use only AC setting on the Weldanpower 250 for thawing pipe. Do not use the max. tap or the CV tap settings for pipe thawing.

Location/Ventilation

The welder should be located to provide an unrestricted flow of clean, cool air to the cooling air inlets. Position the welder so that heated air coming out of the top does not recirculate back to the cooling air inlet. Also, locate the welder so that engine exhaust fumes are properly vented to an outside area.

Angle of Operation

Engines are designed to run in the level condition which is where the optimum performance is achieved. The maximum angle of operation for the Perkins engine is 15 degrees continuously in any direction. If the engine is to be operated at an angle, provisions must be made for checking and maintaining the oil level at the normal (FULL) oil capacity in the crankcase.

When operating the welder at an angle, the effective fuel capacity will be slightly less than the specified 10 gallons (37.8 liters).

High Altitude Operation

At higher altitudes, output derating may be necessary. As a rule of thumb, derate the welder output 0.4% for every 100 ft (30 m) above 500 ft (150 m).

Contact a Perkins Service Representative for any engine adjustments that may be required.

Additional Safety Precautions

Always operate the welder with the hinged door closed and the side panels in place as these provide maximum protection from moving parts and insure proper cooling air flow.

Read carefully the Safety Precautions page in the Instruction Manual before operating this machine. Always follow these and any other safety procedures included in this manual and in the Engine Instruction Manual.

ENGINE OPERATION

Engine Control Function/Operation

“GLOW PLUG” PUSHBUTTON

Depress to activate glow plugs to preheat engine for starting. (See Starting/Shutdown Instructions) on page 23.

WARNING: Under no conditions should ether or other starting fluids be used with the glow plugs.

“START” Pushbutton

Energizes the starter motor to crank the engine. Push and hold in to crank the engine; release as the engine starts. Do not press while engine is running since this can cause damage to the ring gear and/or starter motor.

“RUN-STOP” Switch

When placed in the “RUN” position, this switch energizes the fuel solenoid and other electric accessories. When placed in the “STOP” position, the flow of fuel to the injection pump is stopped to shut down the engine.

OIL PRESSURE LIGHT

The “Red” oil pressure light remains off with proper oil pressure. If light turns on, stop the engine and consult engine Operator’s Manual. (NOTE: light should be on when “Run-Stop” switch is in the “Run” position with engine not running.)

WATER TEMPERATURE LIGHT

The “Red” water temperature light remains off under normal operating temperatures. If light turns on, the engine will shut down. Check for restrictions at the cooling air inlets (on control panel end and engine end of machine), the hot air exhaust, and the engine cooling system (consult the engine Operator’s Manual). Check engine radiator fan and fan belt. Also check to be sure the welder loads are within the rating of the welder.

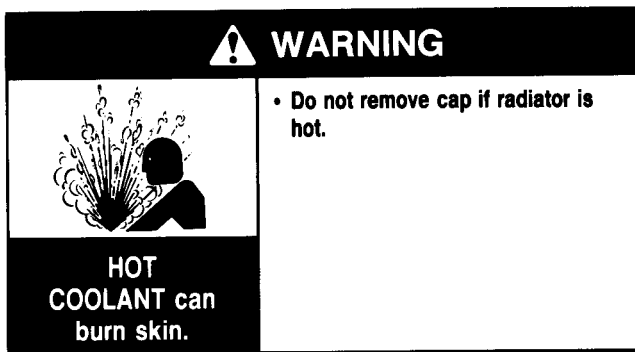

“IDLER CONTROL” Switch (WELDPower 250 D10)

Has two positions as follows:

1. In the “High Idle” position, the idler is off and the engine runs at the high idle speed controlled by the governor.
2. In the “Automatic Idle” position, the idler operates as follows:
 - a. When welding or drawing power for lights or tools (approximately 100-150 watts minimum) from the receptacles, the engine operates at full speed.
 - b. When welding ceases or the power load is turned off, a preset time delay of about 15 seconds starts. This time delay cannot be adjusted.
 - c. If the welding or power load is not restarted before the end of the time delay, the idler reduces the engine to low idle speed.
 - d. The engine will automatically return to high idle speed when the welding load or power load is reapplied.

NOTE: When welding on the “Constant Voltage” tap or with the K799 Hi-Freq, the Idler Control switch must be placed in the “High Idle” position. The idler does not function properly when “Constant Voltage” welding or TIG welding.

“IDLER CONTROL” Switch (Weldanpower 250 D10 PRO)

Has two positions, “High Idle” and “Automatic Idle”.

In the “High Idle” position, the unit operates as follows:

The engine will run at high idle speed since the circuit to the idler is turned off.

- a. In the **Constant Voltage** mode, the output contactor will be closed when using wire feeders with no control cable (LN-22 type; 4 to 244 jumpered on terminal strip). For wire feeders with a control cable (LN-7 type), the contactor is controlled by the wire feeder gun trigger.

- b. In the **Constant Current** mode, the output contactor is bypassed and the output terminals are always energized (“hot”).

In the “Automatic Idle” position, the idler operates as follows:

- a. **Auxiliary Power:** With the engine running at low idle and a load (approximately 100-150 watts minimum) is drawn from the receptacles, the engine will accelerate to high idle. **NOTE:** The CV output contactor will remain open and, therefore, the welder output terminals are “cold” if set for CV welding and “hot” if set for CC welding. When the power load is turned off, a preset time delay of about 10 seconds starts. If the power load is not restarted within that time delay, the idler reduces the engine speed to low idle.
- b. **Constant Current Mode:** With the engine running at low idle and the electrode touches the work, the engine accelerates to high idle. **NOTE:** The CV output contactor is bypassed and, therefore, full voltage is at the output terminals whenever engine is at high idle. When welding ceases, a preset time delay of about 10 seconds starts. If welding is not restarted within that time delay, the idler reduces the engine speed to low idle.
- c. **Constant Voltage Mode** (using a wire feeder that **does not** have a control cable connected to the welder terminal strip; 4 to 244 jumpered on terminal strip): With the engine running at low idle and the electrode is touched to work, the engine will accelerate to high idle and one second later the contactor will close. **NOTE:** Contactor will then be closed whenever unit is at high idle. When welding ceases, a preset time delay of about 10 seconds starts. If welding is not restarted within that time delay, the contactor opens and the idler reduces the engine speed to low idle.

CAUTION: If **also** using auxiliary power when welding ceases, the contactor will open after the 10-second time delay, but the engine will remain at high idle. To reclose the contactor, the electrode must be touched to work.

NOTE: When using an LN-25 with an optional contactor, place the idler switch in the “High Idle” position. The idler circuit will not function properly with a contactor in the LN-25.

- d. **Constant Voltage Mode** (using a wire feeder that **does** have a control cable connected to the welder terminal strip): With the engine running at low idle and the electrode is touched to work, the engine will accelerate to high idle. The contactor will now close when the gun trigger is depressed and open when the trigger is released. When welding ceases, a preset time delay of about 10 seconds starts. If welding is not restarted within that time delay, the idler reduces the engine speed to low idle.

NOTE: When TIG welding with the K799 Hi-Freq Kit, the Idler Control switch must be placed in the “High Idle” position. The idler circuit will not function properly while TIG welding.

BATTERY CHARGING AMMETER

Displays the current going from the battery charging alternator into the battery. It is normal for the charging current to be high after starting or when the battery is “low” on charge.

“FUEL LEVEL” GAUGE

Displays the level of fuel in the 10-gallon fuel tank.

Starting/Shutdown Instructions

Be sure all Pre-Operation Maintenance has been performed. (See “Pre-Operation Maintenance” Section beginning on page 19.)

Remove all loads connected to the AC power receptacles to start the engine, set the “Idler Control” switch in the “Automatic Idle” position. Place the “Run-Stop” switch in the “Run” position. Press the “Glow Plug” pushbutton for 10-30 seconds and then press the “Start” button. Release both buttons when the engine starts.

NOTE: Extreme cold weather may require longer glow plug operation.

If engine fails to start in 30 seconds, place run-stop control in stop position to reset engine protection system (when provided). Wait 30 seconds before repeating above procedure.

If the unit is equipped with the engine protection system (low oil pressure) and the engine is not running within 60 seconds from the time the “Run-Stop” switch was placed in the “Run” position, the “Run-Stop” switch must be recycled. That is, it **must** be placed in the “Stop” position and then again in the “Run” position when ready to start the engine. The reason for this is that the protection system has a magnetic switch with a built-in time delay of 60 seconds, and it must sense oil pressure within that period. If no oil pressure is developed within 60 seconds, the protection system will shut off the fuel supply.

Allow engine to warm up for 5-10 minutes on “Automatic Idle” (low engine speed) before switching to “High Idle” or applying a load.

When an engine is started for the first time, some of the oil will be needed to fill the passages of the lubricating system. Therefore, on initial starting, run the engine for about five minutes and then stop the engine and recheck the oil. If the level is down, fill to the full mark again.

COLD WEATHER STARTING

With a fully charged battery and the proper weight oil, the engine will start satisfactorily down to +10°F (–12°C).

Starting below +10°F (–12°C) may require winter grade diesel fuel and longer glow plug operation.

If the engine must be started below –5°F (–20°C) heaters may be necessary.





WARNING: Under no condition should ether or other starting fluids be used.

STOPPING THE ENGINE

Remove all welding and auxiliary power loads and allow engine to run at “Low Idle” speed for a few minutes.

Stop the engine by placing the “RUN-STOP” switch in the stop position.

WELDER OPERATION

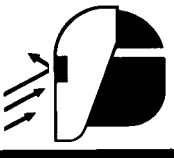
 WARNING	
 ELECTRIC SHOCK can kill.	<ul style="list-style-type: none"> • Do not touch electrically live parts or electrode with skin or wet clothing. • Insulate yourself from work and ground.
 FUMES AND GASES can be dangerous.	<ul style="list-style-type: none"> • Keep your head out of fumes. • Use ventilation or exhaust to remove fumes from breathing zone.
 WELDING SPARKS can cause fire or explosion.	<ul style="list-style-type: none"> • Keep flammable material away. • Do not weld on containers that have held combustibles.
 ARC RAYS can burn.	<ul style="list-style-type: none"> • Wear eye, ear and body protection.

Duty Cycle

The Woldanpower 250 D10 and Woldanpower 250 D10 PRO are rated at 100% duty cycle on all welding taps and auxiliary power.

Control Function/Operation

“OUTPUT SELECTOR” Switch (Weldanpower 250 D10)

An eight-position switch with designated welding currents as follows: CV, 45, 65, 90, 120, 160, 200 and 250. (The CV tap provides a maximum of 200 amps DC for constant voltage welding.)

“OUTPUT SELECTOR” Switch (Weldanpower 250 D10 PRO)

An eleven-position switch with designated welding currents as follows: HIGH, MED-HIGH, MED-LOW, LOW, 45, 65, 90, 120, 160, 200, 250. The HIGH, MED-HIGH; MED-LOW, and LOW taps are for constant voltage welding up to 250 amps DC. The “45” through “250” taps are for constant current welding up to 250 amps AC or 250 amps DC. (See Control Panel on page 8.)

CAUTION: Never change the “OUTPUT SELECTOR” Switch setting while welding. This will cause severe damage to the switch.

“ELECTRODE POLARITY” Switch (Weldanpower 250 D10)

A three-position switch with designated welding polarities as follows: AC, DC(+) and DC(-).

“ELECTRODE POLARITY” Switch (Weldanpower 250 D10 PRO)

A five-position switch with designated welding polarities as follows: AC, DC(-), and DC(+) for constant current welding; DC(+) and DC(-) for constant voltage welding.

CAUTION: Never change the “ELECTRODE POLARITY” Switch setting while welding. This will cause severe damage to the switch.

“OUTPUT CONTROL”

Provides welding current adjustment between the Output Selector Switch settings in the CC mode and welding voltage control with the Output Selector in the CV mode.

WELDING VOLTMETER (On K1334CV-1 Only)

The Welding Voltmeter displays the welding voltage at the output terminals. The Voltmeter only functions with the Output Selector and Electrode Polarity set on CV.

“REMOTE CONTROL” Switch (On K1334CV-1 Only)

The toggle switch on the control panel labeled “Output Control at Welder” and “Remote Output Control” gives the operator the option of controlling the output at the welder control panel or at a remote station.

For remote control, the toggle switch is set in the

“Remote Output Control” position and controlled at the wire feed unit, K775 Remote Control or Amptrol.

For control at the welder control panel, the toggle switch is set in the “Output Control at Welder” position. (Exception: When used with an LN-9 wire feeder, the toggle switch must be in the “Remote Output Control” position or automatic shutdown of the wire feeder may occur.)

Procedure Adjustment



Constant Current (Manual) Welding

Connect welding cables to the “TO WORK” and “ELECTRODE” studs. Start the engine and set the idler switch to the desired operating mode. Set the output selector switch to the desired welding current, the electrode polarity switch to the desired polarity and the machine is ready for welding. A fine adjustment of the welding current can be made with the “Output Control” or a “Remote Output Control” (K775) on WP 250 D10 PRO units with “Remote Control” capabilities.

NOTE: Wire feeder connections at terminal strip do not affect Constant Current Welding.

The Weldanpower 250 D10 and Weldanpower 250 D10 PRO can be used with a broad range of AC and DC stick electrodes. See the latest Weldirectory M210 for the electrodes within the rating of this unit.

It is recommended that the “Output Selector” switch be set for the closest desired CC welding current and then a fine adjustment be made with the “Output Control”. In this way, the “Output Control” will be towards its maximum setting (10) and will give the best arc stability and maximum auxiliary power. Some arc instability may be experienced when the “Output Control” is set towards the low end of its control (1).

 WARNING	
	<ul style="list-style-type: none">• In constant current mode (stick) the electrode is electrically “Hot” at all times.• When welding must be performed in electrically hazardous conditions such as wet areas or confined spaces use the “Automatic idle” position or a wire feeder which provides “cold” electrode. See “Connection of Wirefeeders”.
ELECTRIC SHOCK can kill.	

Constant Voltage (Semiautomatic) Welding

Weldanpower 250 D10

Connect a wire feeder to the Weldanpower 250 D10 and set welder controls according to the instructions

for the WP 250 D10 on page 12.

The welding range is limited to the recommended processes given in the table below. If the "Output Control" is adjusted to obtain lower welding voltages outside the recommendations, the Contactor Kit or the LN-7 may malfunction due to the auxiliary power voltage falling below 98 volts.

The table below shows the electrode and process which can be used with the LN-22/LN-25 and the LN-7/K240 combination.

Wire Feeder	Electrode		in./min
	Size (mm)	Type	
LN-22, LN-25 LN-7 & K240	.068 (1.7)	NR-211-MP	55-90

Weldanpower 250 D10 PRO

Connect a wire feeder to the Weldanpower 250 D10 PRO and set welder controls according to the instructions for the WP 250 D10 PRO beginning on page 12. Install Remote Output Control (if provided) according to the "Remote Output Control." instructions on page 19.

The Weldanpower 250 D10 PRO, with its CV taps, permits it to be used with a broad range of flux cored wire (Innershield and Outershield) and solid wires for gas metal arc welding.

Some recommended Innershield electrodes in small diameters up to and including $\frac{5}{64}$ " (2.0 mm) are: NR-311, NR-211-MP, NR-203 series, Lincore 33 and 55. $\frac{3}{64}$ " (2.0 mm) NS-3M can be welded in limited applications. Cable length and other conditions can affect the ultimate results of this application.

Some recommended Outershield electrodes are: .045, .052 and $\frac{1}{16}$ " (1.1, 1.3 and 1.6 mm) Outershield 71, and $\frac{1}{16}$ " (1.6 mm) Outershield 70.

Some recommended solid wires for gas metal arc welding are: .030, .035 and .045" (0.8, 0.9 and 1.1 mm) L-50 and L-56 Lincolnweld® electrode.

For any electrodes, including the above recommendations, the procedures should be kept within the rating of the machine. For additional electrode information, see Lincoln publications N-675, GS-100, GS-210, H333.1, and H355.1.

Auxiliary Power

Start the engine and set the idler control switch to the desired operating mode. Voltage is now at the receptacles for auxiliary power.

115 Volt Circuit: Up to 86 amps can be drawn in combination from two 20 amp grounding type duplex receptacles protected by a 40 amp circuit breaker, and one 50 amp 115/230 dual voltage receptacle protected by two 45 amp circuit breakers.

230 Volt Circuit: 45 amps can be drawn from the 50

amp 115/230 dual voltage receptacle protected by two 45 amp circuit breakers.

The auxiliary power receptacles should only be used with three wire grounded type plugs or approved double insulated tools with two wire plugs.

The current rating of any plug used with the system must be at least equal to the current load through the associated receptacle. Do not attempt to connect power receptacles in parallel.

Most 1.5 HP motors can be started if there is no load on the motor or other load connected to the machine, since the full load current rating of a 1.5 HP motor is approximately 20 amperes (10 amperes for 230 volt motors). The motor may be run at full load when plugged into only one side of the duplex receptacle. Larger motors through 2 HP can be run provided the receptacle rating as previously stated is not exceeded. This may necessitate 230 V operation only.

It must be noted that the above auxiliary power ratings are with no welding load. Simultaneous welding and power loads are permitted by the following Tables on page 26. The permissible currents shown assume that current is being drawn from either the 115 volt or 230 volt supply (not both at the same time). Also, the "Output Control" is set at "10" for maximum auxiliary power. NOTE: Permissible watts decrease as "Output Control" is adjusted toward "1".

Operation of Options/Accessories

TIG Welding

The Weldanpower 250 D10 and Weldanpower D10 PRO may be used with the K799WP3 High Frequency Generator. The combined package will permit AC or DC TIG welding up through 200 Amps.

The K799WP3 should be used with the Weldanpower 250 on high idle to maintain satisfactory operation. See K799 Operating Manual for details on the K799's operation.

BREAK-IN PERIOD

The engine used to supply power for your welder is a heavy-duty industrial engine. It is designed and built for rugged use. It is very normal for any engine to use small quantities of oil until the break-in is accomplished. We suggest checking the oil level twice a day during the break-in period (about 50 running hours).

IMPORTANT: In order to accomplish this break-in, the unit should be subjected to moderate loads, within the rating of the machine. Avoid long idle running periods. Remove loads and allow engine to cool before shutdown.

TABLE I
Weldanpower 250 D10

Output Selector Setting	Permissible Power Watts (Unity Power Factor)	Permissible Auxiliary Current in Amperes	
		@ 115V	or @ 230V
250	NONE	0	0
200	3000	26	13
160	3500	30	15
120	5500	48	24
90	6500	56	28
65	7500	65	32.5
45	8500	74	37
CV ⁽¹⁾	3000	26	13

⁽¹⁾ When LN-7 and K240 are being used on the CV tap, sufficient power is available for these two units provided auxiliary power voltage remains above 98 volts.

TABLE II
Weldanpower 250 D10 PRO

Output Selector Setting	Welding Output	Permissible Power Watts (Unity Power Factor)	Permissible Auxiliary Current in Amperes	
			@ 115V	or @ 230V
250	250	NONE	0	0
200	200	3000	26	13
160	160	3500	30	15
120	120	5500	48	24
90	90	6500	56	28
65	65	7500	65	32.5
45	45	8500	74	37
CV Low	200 40	7000 9500	60 82	30 41
CV Med. Low	250 60	5500 8500	48 74	24 37
CV Med. High	250 80	3500 7000	30 60	15 30
CV High	250 100	1500 6000	13 52	6.5 26

See Standby Power Connections Section on page 11 for installation as a standby power unit.

MAINTENANCE

SAFETY PRECAUTIONS



WARNING



MOVING PARTS can injure.

- Have qualified personnel do maintenance and troubleshooting work.
- If possible, turn the engine off and disconnect the battery before working inside the machine.
- Remove guards only when necessary to perform maintenance, and replace them when the maintenance requiring their removal is complete.
- Keep hands, hair, clothing and tools away from V-belts, gears, fans and all other moving parts.
- If fan guards are missing from a machine, obtain replacements from a Lincoln Distributor. (See Operating Manual Parts List.)
- Read the Safety Precautions in front of this manual and the engine instruction manual before working on this machine.

ROUTINE MAINTENANCE

1. At the end of each day's welding, refill the fuel tank to minimize moisture condensation in the tank. Also, running out of fuel tends to draw dirt into the fuel system. Check the crankcase oil level.
2. If the fuel runs out while the fuel pump is operating, air may be entrapped in the fuel distribution

system. If this happens, bleeding of the fuel system may be necessary. See the engine Operator's Manual.

3. Refer to the engine maintenance section in the engine Operator's Manual for routine engine maintenance.
4. **Air Filter** — The air filter canister is located behind the engine door on the right side of the welder.

The air filter element is a dry cartridge type. It can be cleaned and re-used; however, damaged elements should not be washed or re-used. Remove loose dirt from element with compressed air or water hose directed from inside out. Compressed Air: 100 psi (689 kPa) maximum with nozzles at least one inch away from element. Water Hose: 40 psi (275 kPa) maximum without nozzle.

WARNING: Be sure you are wearing proper eye protection and direct flow of material away from yourself and others.

Soak element in a mild detergent solution for 15 minutes. Do not soak more than 24 hours. Swish element around in the solution to help remove dirt. Rinse elements from inside out with a gentle stream of water [less than 40 psi (275 kPa)] to remove all suds and dirt. Dry element before re-use with warm air at less than 160°F (71°C). Do not use a light bulb to dry the element.

Inspect for holes and tears by looking through the

element toward a bright light. Check for damaged gaskets or dented metal parts. Do not re-use damaged elements. Protect element from dust and damage during drying and storage.

- Both English and Metric fasteners are used on this welder.

NOTE: Low Oil Pressure Shutdown System will protect engine from sudden loss of oil pressure. It may not protect engine from damage if the engine is run with oil levels below the recommended level. Proper oil level must be maintained. Consult engine operator's manual for proper grade and viscosity of oil.

PERIODIC MAINTENANCE

- Blow out the welder and controls with low pressure air periodically. In particularly dirty locations this may be required once a week.
- Throttle Control parts must be kept clean and lubricated.
- Refer to engine Operator's Manual for periodic engine maintenance.

- A slight amount of darkening and wear of the slip rings and brushes is normal. Brushes should be inspected when a general overhaul is necessary.
- When replacing, jumping, or otherwise connecting the battery to the battery cables, the proper polarity must be observed. Failure to observe the proper polarity could result in damage to the charging circuit. The positive battery cable is designed with a "P" stenciled on the terminal and the negative battery cable has an "N" stenciled on the terminal.
- Nameplates — Whenever periodic maintenance is performed on this machine — or at least yearly — inspect all nameplates and labels for legibility. Replace those which are no longer clear. Refer to the parts list for replacement item number.
- With the engine off, check for correct functioning of the water temperature light by jumping the terminal on the water temperature switch (#220), on the starter side of the engine, to the engine block. The water temperature light should come on. Check light bulb and wiring if light fails to turn on.

TROUBLESHOOTING

TROUBLE	POSSIBLE CAUSE	REMEDY
No welder or power output.	<ol style="list-style-type: none"> Flashing circuit fuse blown. Open lead in flashing or field circuit. Faulty rotor. Faulty rheostat (R4). Faulty stator field winding. Faulty field rectifier (D2). Faulty flashing diode (D3). Open in misc leads. Output contactor does not pull in. Remote control fuse blown (F4). Faulty remote control P.C. board. 	<ol style="list-style-type: none"> Replace with a new 8 amp "Slow-Blow" fuse. Refer to wiring diagram and check related leads. Lift brushes and check rotor continuity between slip rings. (Should be 4 to 5 ohms). Rheostat resistance should be approximately 13 ohms when set at 1. Disconnect lead #4 at D2 and check for continuity between leads #4 and #5. Replace with known good one. Replace with known good one. Refer to wiring diagram & check related leads. See "Contactor does not pull in" section of Troubleshooting Chart. Replace with a new 8 amp "Slow-Blow" fuse. Replace with known good one.

TROUBLE	POSSIBLE CAUSE	REMEDY
Battery does not stay charged.	<ul style="list-style-type: none"> a. Faulty battery. b. Faulty charging system. c. Loose connection or broken leads in charging circuit. 	<ul style="list-style-type: none"> a. Replace with new battery. b. Refer to engine Operator's Manual for charging system service. c. Refer to wiring diagram and check related leads.
Engine will not idle down to low speed.	<ul style="list-style-type: none"> a. Idler switch on High Idle. b. External load on welder or auxiliary power. c. No voltage present between terminals #213 & #5. (Voltage should be 12 VDC). d. Battery disconnected. e. No open circuit voltage on the auxiliary power receptacles. f. No voltage present between terminals #3 & #5. (Voltage should be 120 VAC). g. K799WP3 Hi-Freq Kit connected to Weldonpower. h. Idler solenoid fuse blown. i. Faulty wiring in solenoid circuit. j. Faulty reed relay (CR3). k. Idler solenoid position out of adjustment. l. Idler relay (CR2) faulty. m. Faulty idler solenoid. n. Faulty idler P.C. board. 	<ul style="list-style-type: none"> a. Set switch on Automatic Idle. b. Remove all external loads and short circuits. c. Check for broken leads #213, #5, and #224. d. Battery must be connected for idler operation. e. Check for generator buildup. f. Check for broken leads #3 and #5. g. Use K799WP3 with Weldonpower on high idle (see Option/Accessories under TIG Welding section) on page 25. h. Replace with a new 8 amp "Slow-Blow" fuse. i. Refer to wiring diagram and check related leads. j. Replace with known good one. k. Adjust solenoid as necessary. The solenoid must be adjusted so that the solenoid shaft seats fully; otherwise, the solenoid will be damaged. l. Check and replace relay if faulty. m. Check and replace solenoid if faulty. n. Replace P.C. board with known good one.
Engine will not go to high idle when attempting to weld.	<ul style="list-style-type: none"> a. No voltage signal from the current sensing transformer. b. No open circuit voltage on output studs. c. Welding on CV tap (Weldonpower 250 D10). d. Weldonpower 250 D10 PRO, CV mode only, no voltage present between terminals 240 and 242 (voltage should be open circuit voltage of welder, DC(+), with 242 as reference.) e. Faulty idler P.C. board. 	<ul style="list-style-type: none"> a. Check current sensing transformer operation. Check for broken leads #218 and #5. b. Check generator output. c. Use on high idle only on Weldonpower 250 D10. d. Check for broken leads #240 and #242. e. Replace P.C. board with known good one.
Engine will not go to high idle when using auxiliary power.	<ul style="list-style-type: none"> a. No voltage signal from the idler current transformer. b. Auxiliary power load less than 1 amp. c. Faulty idler P.C. board. 	<ul style="list-style-type: none"> a. Check idler current transformer operation. Check for broken leads #218, #3, and #5 on the idler current transformer. b. Idler will not function with less than 1 amp load. Set idler switch to high idle. c. Replace P.C. board with known good one.
Engine goes to low idle but does not stay at low idle.	<ul style="list-style-type: none"> a. Idle speed set too low. b. Idler solenoid not seating properly. c. Faulty solenoid. 	<ul style="list-style-type: none"> a. Adjust solenoid linkage to set speed at 1900 RPM. b. Adjust solenoid as necessary. The solenoid must be adjusted so that the solenoid shaft seats fully; otherwise, the solenoid will be damaged. c. Replace solenoid with known good one.

TROUBLE	POSSIBLE CAUSE	REMEDY
<p>Contactor does not pull in.</p>	<p>a. Welding in CC mode. b. Incorrect connection to terminal strip. 1) Wire feeders with no control cable. 2) Wire feeders with control cable.</p> <p>c. Faulty wiring in contactor circuit.</p> <p>d. Wire feeders with no control cable; no voltage present between terminals #240 to #242 (voltage should be open circuit voltage of machine, DC(+) with #242 as reference).</p> <p>e. Faulty contactor (CR5). f. Faulty idler P.C. board (only for wire feeders with no control cable).</p>	<p>a. Contactor is only used for CV welding. b. 1) Jumper #244 to #4 on terminal strip. 2) Terminals #244 and #4 should not be jumpered. Leads from wire feeder must be connected to terminals #2 and #4. Terminals must close when trigger is pulled.</p> <p>c. Check for broken leads #204, #229, #5, #243 and #244. d. Check for broken leads #240 and #242.</p> <p>e. Replace contactor with known good one. f. Replace P.C. board with known good one.</p>
<p>Contactor does not drop out.</p>	<p>a. Faulty wiring in terminal strip area. b. Wire feeders with control cable. 1) Faulty control cable. 2) Faulty wire feeder. c. Wire feeders with no control cable; faulty idler P.C. board.</p>	<p>a. Check that lead #4 is not connected to #2 or #5 on terminal strip. b. 1) Replace with known good one. 2) Replace wire feeder with a known good one. c. Replace idler P.C. board with a known good one.</p>
<p>"Output Control" on welder not functioning (Remote Control units only).</p>	<p>a. Output control switch in wrong position. b. Output control switch defective. c. Output control potentiometer defective. d. Faulty wiring in control circuit. e. Fuses on remote control P.C. board blown. f. Faulty remote control P.C. board.</p>	<p>a. Place switch in "LOCAL" position. b. Check and replace switch, if faulty. c. Check and replace potentiometer, if faulty. d. Check for broken leads #75, 77, 293, 294. e. Replace with a new 1/8 amp fuse. f. Replace P.C. board with known good one.</p>
<p>"Output Control" on remote not functioning (Remote Control units only).</p>	<p>a. Output control switch in wrong position. b. Leads A, B, and C or 75, 76, and 77 not connected to correct numbers on terminal strip. c. Remote control leads broken in control cable. d. Faulty wiring in control circuit. e. Fuses on remote control P.C. board blown. f. Faulty wire feeder. g. Faulty remote control P.C. board.</p>	<p>a. Place switch in "REMOTE" position. b. Correct connection. c. Repair broken leads. d. Check for broken leads #75, 76, 77, 293. e. Replace with a new 1/8 amp fuse. f. Replace wire feeder with a known good wire feeder. g. Replace P.C. board with known good one.</p>

GENERAL ASSEMBLY

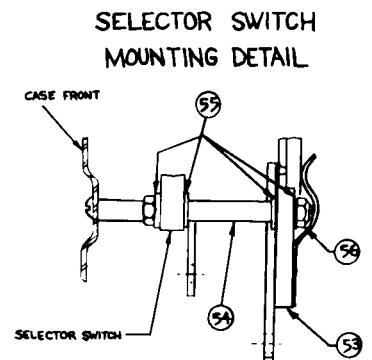
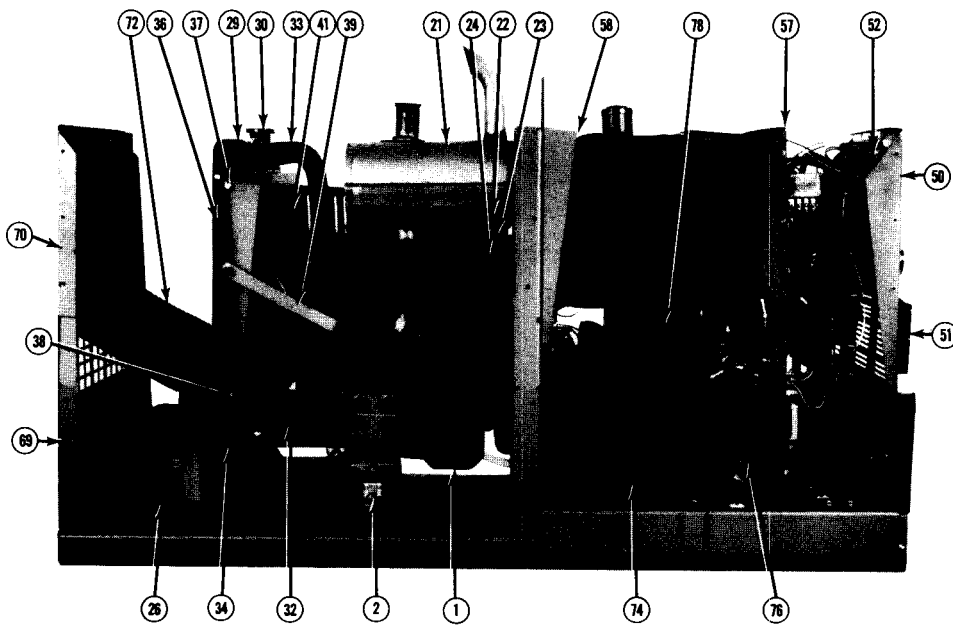
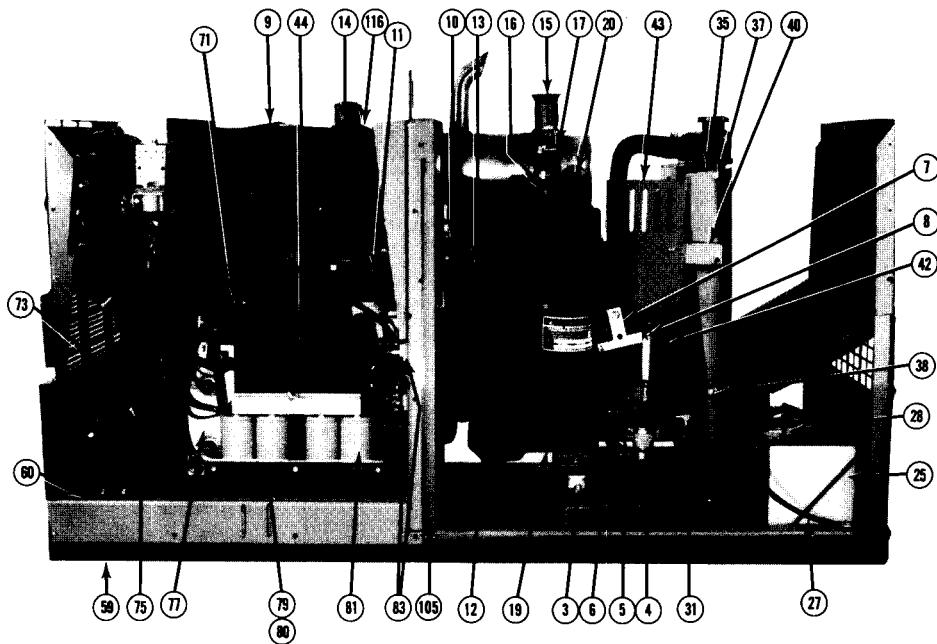

WHEN ORDERING GIVE: Item No., Part Name, Parts List No., and Welder Code.

See Perkins parts list or service shop for information on engine parts.

G1796
5-20-88D

Parts List P-178-C

ITEM	PART NAME & DESCRIPTION	NO. REQ'D
2	Engine Mounting (Right Side)	1
3	Engine Mounting (Left Side)	1
4	Idler Solenoid Assembly	1
5	Thread Forming Screw	2
	Idler Spring Bracket	1
6	Spring (Idler)	1
	Idler Arm	1
7	Hex Head Cap Screw	1
	Lock Washer	1
	Hex Jam Nut	1
	Pivot Pin	1
8	Plain Washer	1
	Spring Clip	1
9	Fuel Tank	1
	Thread Forming Screw	4
	Fuel Filter	1
10	Hex Head Cap Screw	1
	Lock Washer	1
	Hex Nut	1
11	Fuel Line (Tank to Lift Pump)	1
	Hose Clamp	2
	Fuel Line (Lift Pump to Filter)	1
12	Sleeving	1
	Hose Clamp	2
	Fuel Line (Filter to Inject Pump)	1
13	Hose Clamp	2
14	Hose Clamp	1
15	Oil Fill Pipe Assembly	1
18	Air Filter Mounting Bracket	1
	Air Filter	1
	Mounting Band	2
19	Hex Head Cap Screw	4
	Lock Washer	4
	Hex Nut	4
20	Air Filter Hose (Out)	1
	Clamp	2
	Muffler	1
21	Gasket	1
	Metric Hex Head Screw (M8 x 1.25 Grade 8.8)	4
	Lock Washer	4
22	Muffler Mounting Bracket	1
	Hex Head Cap Screw	1
23	Plain Washer	1
	Lock Washer	1
	Hex Nut	1
	Metric Hex Head Screw (M8 x 1.25 Grade 8.8)	1
24	Plain Washer	1
	Lock Washer	1
	Battery	1
	Battery Clamp Bracket	1
25	Clamp Hook	2
	Lock Washer	2
	Hex Nut	2
26	Battery Cable (Positive)	1
	Hex Nut	1
	Battery Cable (Negative)	1
27	Hex Head Cap Screw	1
	Lock Washer	1
	Hex Nut	1
29	Radiator	1
30	Radiator Cap	1
31	Drain Cock	1
	Sealant	1

ITEM	PART NAME & DESCRIPTION	NO. REQ'D
	Hose (Bottom)	1
32	Clamp	1
	Clamp	1
	Hose	1
33	Clamp	1
	Clamp	1
34	Radiator Mount Assembly	1
35	Left Radiator Baffle	1
	Right Radiator Baffle	1
36	Hex Head Cap Screw	2
37	Plain Washer	2
	Lock Washer	2
	Hex Head Cap Screw	2
	Plain Washer	2
38	Lock Washer	2
	Rubber Washer	2
	Left Radiator Support	1
39	Rubber Mount	1
	Metric Hex Head Screw (M8 x 1.25 Grade 5.6)	1
	Plain Washer	1
	Lock Washer	2
	Hex Nut	1
	Right Radiator Support	1
	Rubber Mount	1
40	Plain Washer	1
	Lock Washer	1
	Hex Nut	1
	Fan	1
42	Lower Fan Guard	1
	Thread Forming Screw	2
43	Upper Fan Guard	1
	Self Tapping Screw	2
	Frame Assembly	1
44	Hex Head Cap Screw	8
	Lock Washer	8
45	Generator Mounting	1
	Bearing	1
	Tolerance Ring	1
	Blower	1
48	Key	1
	Hex Head Cap Screw	1
	Plain Washer	1
	Lock Washer	1
49	Brushholder Assembly	1
	Brush	2
50	Case Front Assembly	1
51	Self Tapping Screw	3
	Louver Assembly	1
	Self Tapping Screw	8
53	Selector Switch	1
	Stat. Contact Rivet Assembly	1
57	Air Baffle Assembly	1
58	Lift Bail Baffle Assembly	1
59	Base	1
60	Base Floor	1
	Thread Forming Screw	2
69	Lower Rear Panel	1
	Thread Forming Screw	4
70	Upper Rear Panel	1
	Self Tapping Screw	2
	Thread Forming Screw	2
71	Fuel Tank Drip Pan	1
	Self Tapping Screw	5
72	Air Intake Baffle	1

Parts List P-178-C (Continued)

ITEM	PART NAME & DESCRIPTION	NO. REQ'D
	Thread Forming Screw Case Front Intake Baffle	4 1
73	Mounting Bracket	2
	Self Tapping Screw	7
74	Reactor Assembly	1
	Thread Forming Screw	3
75	Choke Assembly	1
	Thread Forming Screw	4
76	Rect. Assembly (Negative)	1
	Self Tapping Screw	2
77	Rect. Assembly (Positive)	1
	Self Tapping Screw	2
	Current Transformer	1
78	Self Tapping Screw	2
	Bushing	2
	Insulating Washer	2
	Capacitor (Early Machines Only - Set of 4)	1
	Capacitor (C2)	1
80	Capacitor Jumper	2
	Round Head Screw	8
81	Capacitor Bank Assembly	1
	Self Tapping Screw	2
82	Reed Switch & Choke	1
	Full Wave Bridge	2 or 1
83	Round Head Screw	2
	Plain Washer	2

ITEM	PART NAME & DESCRIPTION	NO. REQ'D
	Lock Washer	2
	Hex Nut	2
105	Grommet	1
	Items Not Illustrated:	
	Rotor & Shaft Assembly	1
	Coupling Assembly	1
	Roof	1
	Self Tapping Screw	4
	Self Tapping Screw	15
	Case Side (Left)	1
	Case Side (Right)	1
	Thread Forming Screw	18
	Self Tapping Screw	11
	Door Assembly	1
	Clip	4
	Self Tapping Screw	4
	Door Latch Assembly	4
	Self Tapping Screw	8
	Door Support Rod	1
	Retaining Clip	1
	Round Head Screw	2
	Lock Washer	2
	Hex Nut	2

10-20-88

LIFT BAIL BAFFLE ASSEMBLY

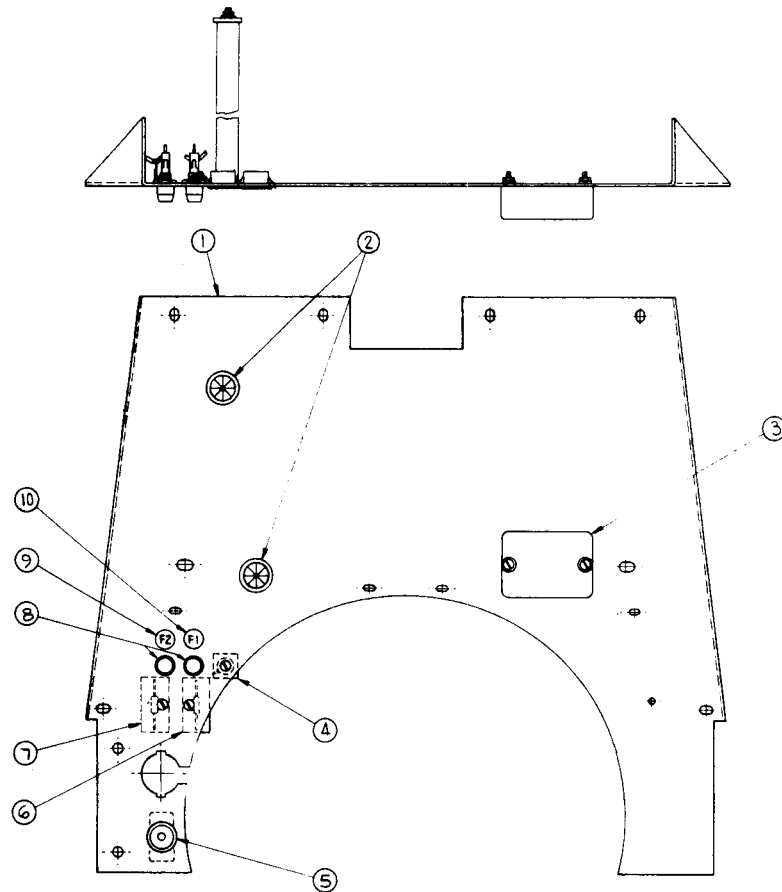

L7443
7-1-88D

Parts List P-178-F

ITEM	PART NAME & DESCRIPTION	NO. REQ'D
1	Lift Bail Baffle	1
2	Bushing	2
3	Engine Regulator	1
4	Resistor - w/o Remote Control	1
4	Resistor - w/Remote Control	1
	Round Head Screw - w/o Remote Control	1
	Round Head Screw - w/Remote Control	1
	Insulating Washer	2
	Plain Washer	1
	Lock Washer	1
	Hex Nut	1
5	Glow Plug Indicator	1
6	Diode Assembly	1
	Insulation	1
7	Diode Assembly	1
	Insulation	1
8	Fuse Holder	2
	Fuse	2
9	I.D. Sticker (F2)	1
10	I.D. Sticker (F1)	1

9-1-88

CASE FRONT ASSEMBLY

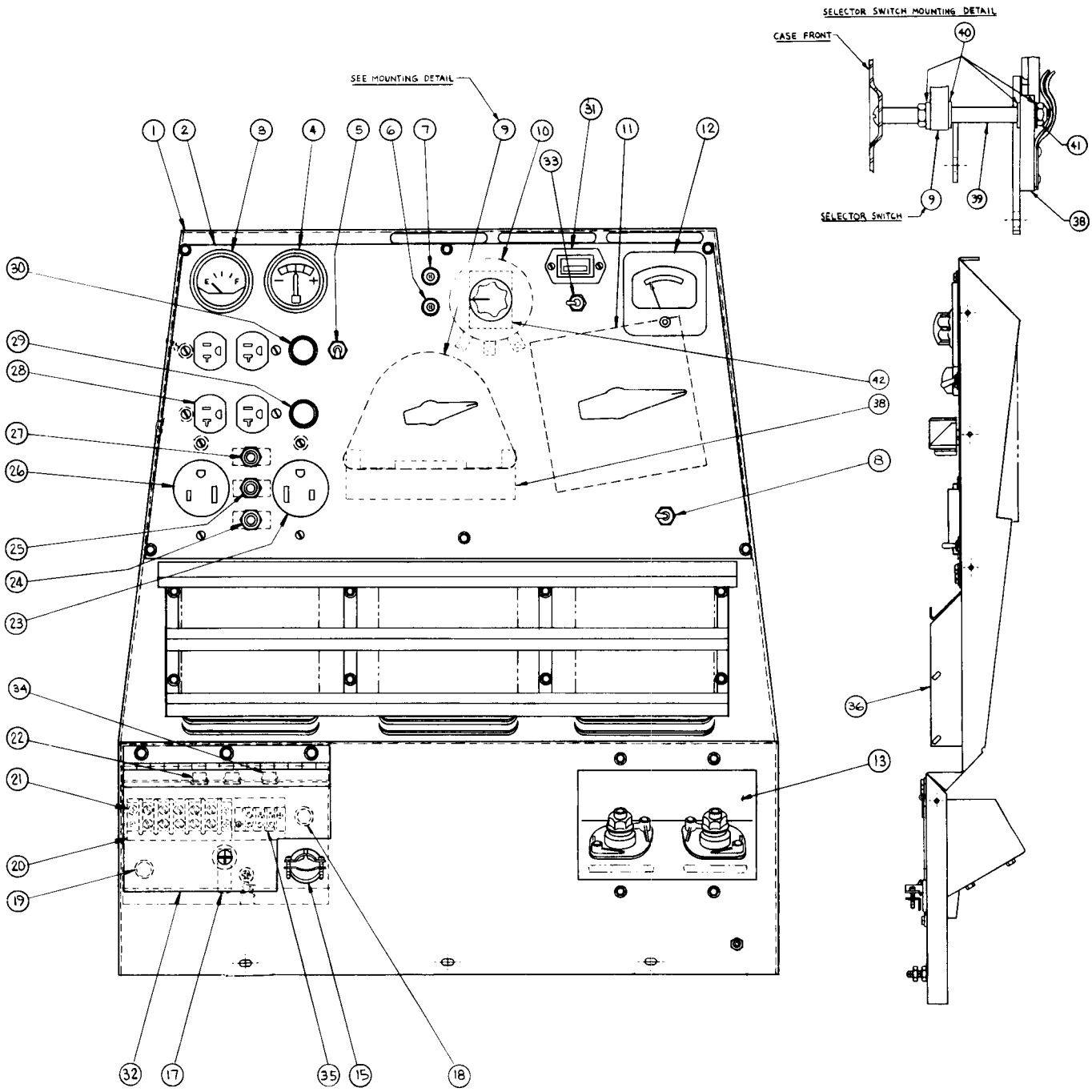

WHEN ORDERING GIVE: Item No., Part Name, Parts List No., and Welder Code.

G1785
1-8-88A

Parts List P-178-D

ITEM	PART NAME & DESCRIPTION	NO. REQ'D
1	Case Front Welded Assembly – D10 PRO	1
1	Case Front Welded Assembly – D10	1
2	Nameplate – D10 PRO – w/o Voltmeter	1
	Nameplate – D10 PRO – w/Voltmeter	1
	Nameplate – D10 PRO – w/Remote Control	1
	Nameplate – D10 PRO w/Remote Control & Voltmeter	1
	Nameplate – D10 w/o Remote	1
	Control – w/Meters	1
	Nameplate – D10 w/o Remote	1
	Control – w/Voltmeter	1
	Nameplate – D10 w/o Remote	1
	Control – w/Hour Meter	1
	Nameplate – D10 w/o Remote	1
	Control – w/Voltmeter & Hour Meter	1
	Nameplate – D10 w/Remote	1
	Control – w/Voltmeter	1
	Nameplate – D10 w/Remote	1
	Control – w/Hour Meter	1
	Nameplate – D10 w/Remote Control – w/Voltmeter & Hour Meter	1
3	Fuel Gauge	1
4	Ammeter	1
5	RUN-STOP Switch	1
6	Water Temperature Light	1
7	Oil Pressure Light	1
8	Idle Switch	1
9	Selector Switch – D10 PRO	1
9	Selector Switch – D10 w/o Meters	1
9	Selector Switch – D10 w/Meters	1
	Control Handle	1
10	Potentiometer w/o Remote Control	1
10	Potentiometer w/Remote Control	1
	Knob	
11	Polarity Switch – D10 PRO w/o Meters	
11	Polarity Switch – D10 PRO w/Meters	

ITEM	PART NAME & DESCRIPTION	NO. REQ'D
11	Polarity Switch – D10	1
	Control Handle	1
12	Voltmeter – D10 PRO – Optional	1
12	Voltmeter – D10 – Optional	1
13	Output Stud Panel, Includes:	1
	Output Stud	2
15	Box Connector – D10 PRO & D10 w/Remote Control	1
17	Door Latch – D10 PRO & D10 w/Remote Control	1
18	Fuse Holder – Remote Control Only	1
	Fuse	1
19	Fuse Holder – D10 PRO Only	1
	Fuse	1
20	Number Plate – D10 PRO w/o Remote Control	1
20	Number Plate – D10 PRO w/Remote Control	1
	Number Plate – D10 w/Remote Control	1
21	Terminal Strip – D10 PRO Only	1
22	Bushing – D10 PRO & D10 w/o Remote Control	2
23	Single Receptacle – (250V)	1
24	Circuit Breaker (50A)	1
25	Circuit Breaker (45A)	1
26	Single Receptacle (115V)	1
27	Circuit Breaker (40A)	1
28	Duplex Receptacle (115V)	2
29	Glow Plug Button	1
30	Start Button	1
31	Hour Meter – Std. on D10 PRO – Option on D10	1
32	Door & Hinge Assembly – D10 PRO & D10 w/Remote Control	1
33	Remote Switch – w/Remote Control Only	1
34	Bushing – D10 PRO w/Remote Control	1
35	Terminal Strip – w/Remote Control Only	1
36	Louver Assembly	1

6-20-89

AIR BAFFLE & COMPONENT ASSEMBLY

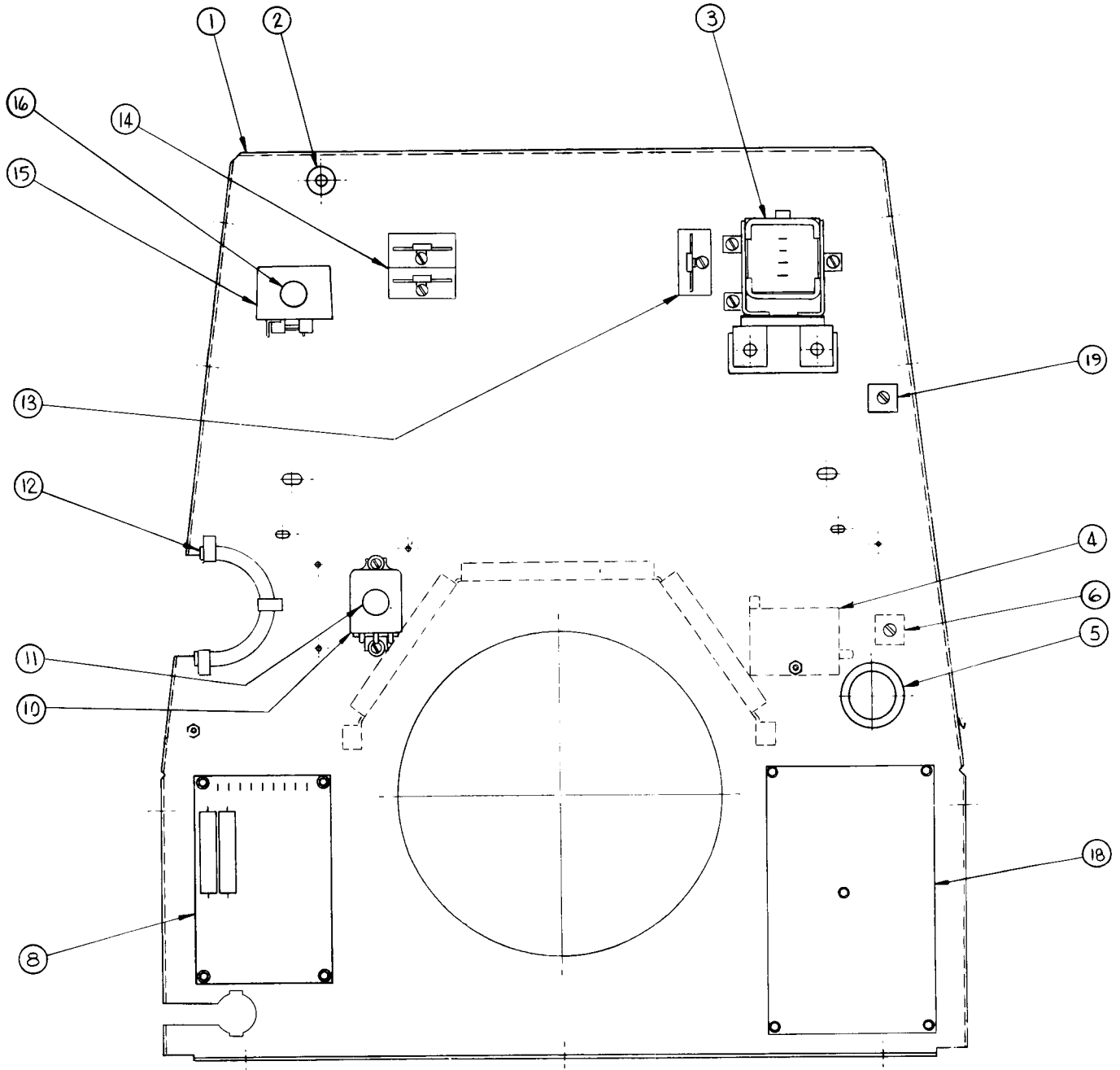

G1780
6-17-88C

WHEN ORDERING GIVE: Item No., Part Name, Parts List No., and Welder Code.

Parts List P-178-E

ITEM	PART NAME & DESCRIPTION	NO. REQ'D
1	Air Baffle & Shroud	1
2	Grommet	1
3	Contacto	1
4	Suppressor Assembly	1
5	Grommet	1
6	Resistor (R5)	1
	Round Head Screw	1
	Insulating Washer	2
	Plain Washer	1
	Lock Washer	1
	Hex Nut	1
8	Idler P.C. Board - D10 PRO	1
8	Idler P.C. Board - D10	1
	Expansion Nut	4
10	Self Tapping Screw	4
	Relay (CR2)	1
11	Identification Sticker	1
12	Rubber Channel	1
13	Diode Assembly - D10 PRO	1
	Insulation	1
	Round Head Screw	1
	Lock Washer	1
	Hex Nut	1

ITEM	PART NAME & DESCRIPTION	NO. REQ'D
14	Diode Assembly - w/Engine Protection Only	2
	Insulation	2
	Round Head Screw	2
	Lock Washer	2
	Hex Nut	2
15	Magnetic Switch (CR3) -	1
	w/Engine Protection Only	
16	Identification Sticker	1
18	Remote Control P.C. Board -	1
	Remote Control Option Only	
	Expansion Nut	5
19	Self Tapping Screw	5
	Resistor (R6) - Remote Control Option Only	1
	Round Head Screw	1
	Insulating Washer	2
	Plain Washer	1
	Lock Washer	1
	Hex Nut	1
	Items Not Illustrated	
	Relay (CR3) - G10 w/o Engine Protection Only	1

9-1-88

WELDANPOWER 250 D10 PRO (With Engine Protection and Remote Control)

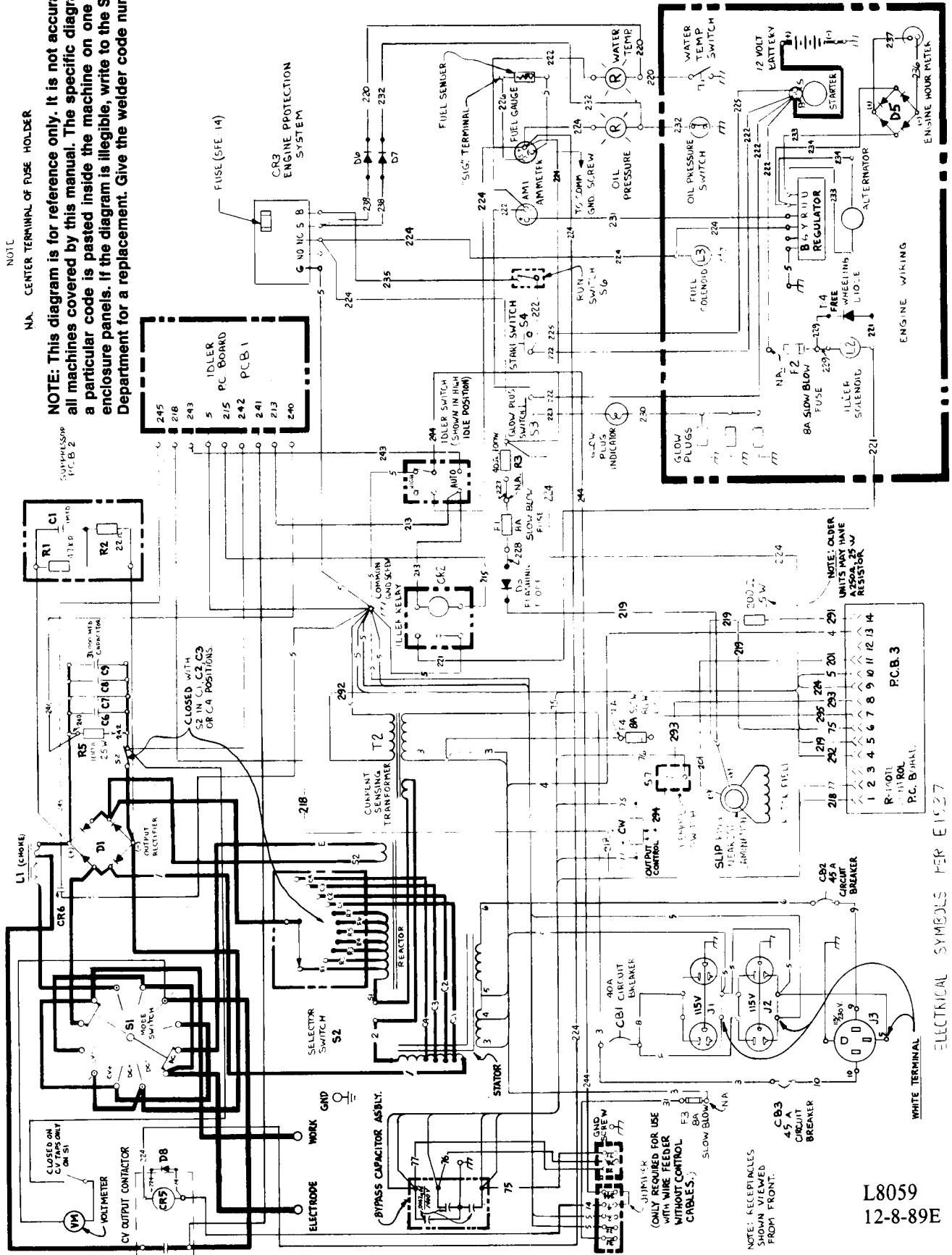

NOTE: This diagram is for reference only. It is not accurate for all machines covered by this manual. The specific diagram for a particular code is pasted inside the machine on one of the enclosure panels. If the diagram is illegible, write to the Service Department for a replacement. Give the welder code number.

NOTE
NA. CENTER TERMINAL OF FUSE HOLDER

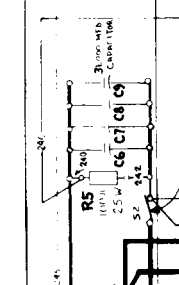
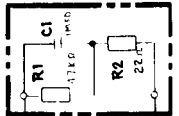
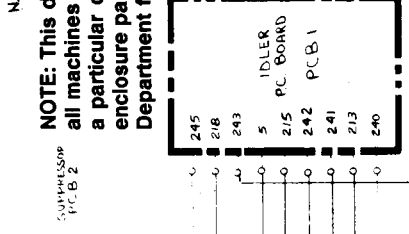

L8059
12-8-89E

ELECTRICAL SYMBOLS PER E1927

WELDANPOWER 250 D10 (With Engine Protection and Hour Meter)

NOTE: This diagram is for reference only. It is not accurate for all machines covered by this manual. The specific diagram for a particular code is pasted inside the machine on one of the enclosure panels. If the diagram is illegible, write to the Service Department for a replacement. Give the welder code number.

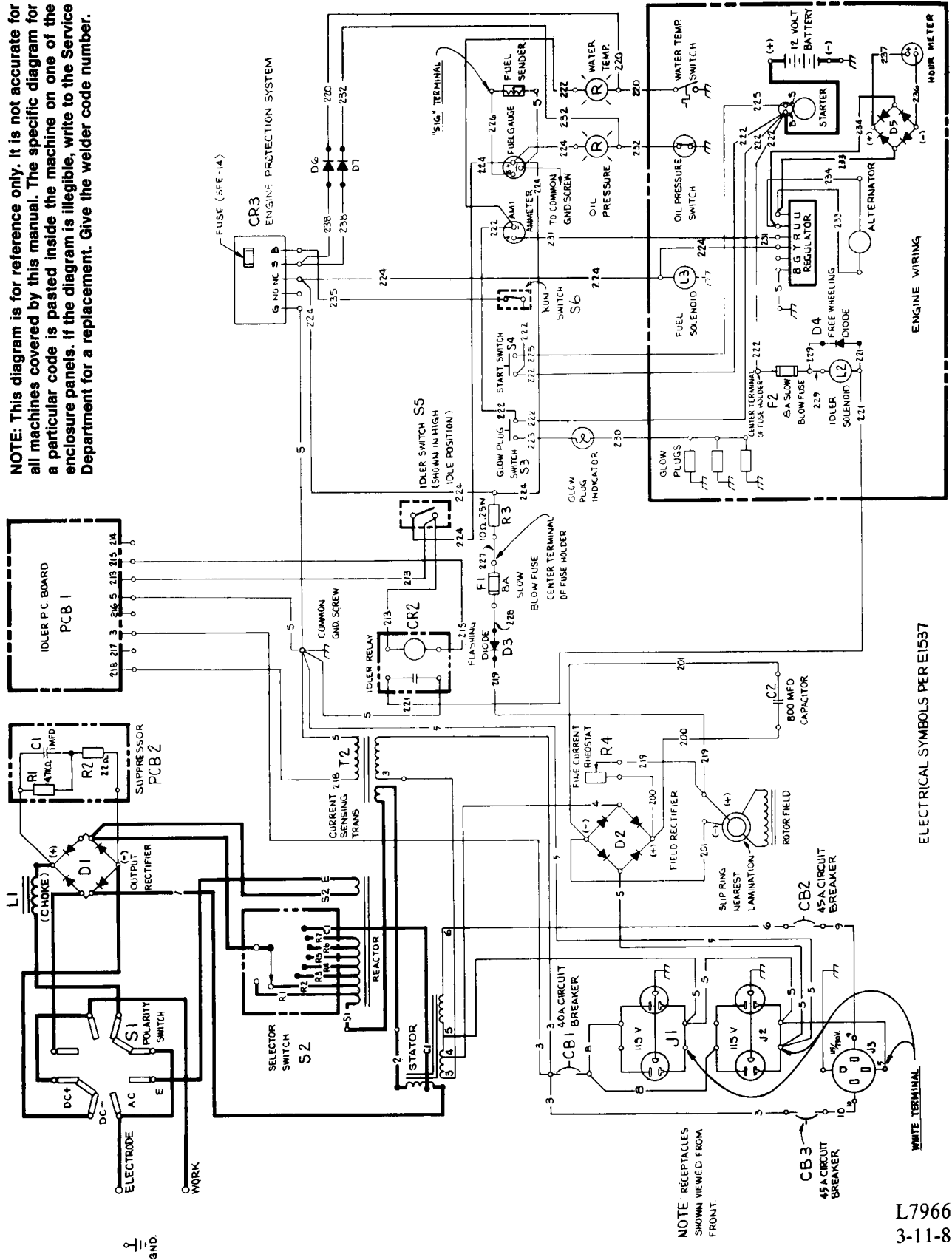

ELECTRICAL SYMBOLS PER E157

NOTE: RECEPTACLES SHOWN VIEWED FROM FRONT.

L7966
3-11-89H

LIMITED WARRANTY

STATEMENT OF WARRANTY:

The Lincoln Electric Company (Lincoln) warrants to the original purchaser (end-user) of new equipment that it will be free of defects in workmanship and material.

This warranty is void if Lincoln finds that the equipment has been subjected to improper care or abnormal operation.

WARRANTY PERIOD:

All warranty periods date from the date of shipment to the original purchaser and are as follows:

Three Years:

Transformer Welders
Motor-generator Welders
Semiautomatic Wire feeders
Plasma-cutting power source
Engine Driven Welders (except engine and engine accessories) with operating speed under 2,000 RPM

Two Years:

Engine Driven Welders (except engine and engine accessories) with operating speed over 2,000 RPM

All engine and engine accessories are warranted by the engine or engine accessory manufacturer and are not covered by this warranty.

Equipment not listed above such as gun and cable assemblies, automatic wire feeders and field-installed optional equipment is warranted for one year.

TO OBTAIN WARRANTY COVERAGE:

You are required to notify Lincoln Electric, your Lincoln Distributor, Lincoln Service Center or Field Service Shop of any defect within the warranty period. Written notification is recommended.

WARRANTY REPAIR:

If Lincoln's inspection of the equipment confirms the existence of a defect covered by this warranty, the defect will be corrected by repair or replacement at Lincoln's option.

WARRANTY COSTS:

You must bear the cost of shipping the equipment to a Lincoln Service Center or Field Service Shop as well as return shipment to you from that location.

IMPORTANT WARRANTY LIMITATIONS:

- Lincoln will not accept responsibility for repairs made without its authorization.
- Lincoln shall not be liable for consequential damages (such as loss of business, etc.) caused by the defect or reasonable delay in correcting the defect.
- Lincoln's liability under this warranty shall not exceed the cost of correcting the defect.
- This written warranty is the **only** express warranty provided by Lincoln with respect to its products. Warranties implied by law such as the Warranty of Merchantability are limited to the duration of this limited warranty for the equipment involved.



THE LINCOLN ELECTRIC COMPANY

World's Largest Manufacturer of Arc Welding Products • Manufacturer of Industrial Motors

Sales and Service Worldwide

Cleveland, Ohio 44117-1199 U.S.A.

Toronto M4G 2B9 - Canada

Sydney 2211 - Australia

Rouen 76120 - France

Eff. Apr. '90

Ram

9-89

Litho in U.S.A.