

FLEXTEC 450 WIRING DIAGRAM G6890-3 REV: A

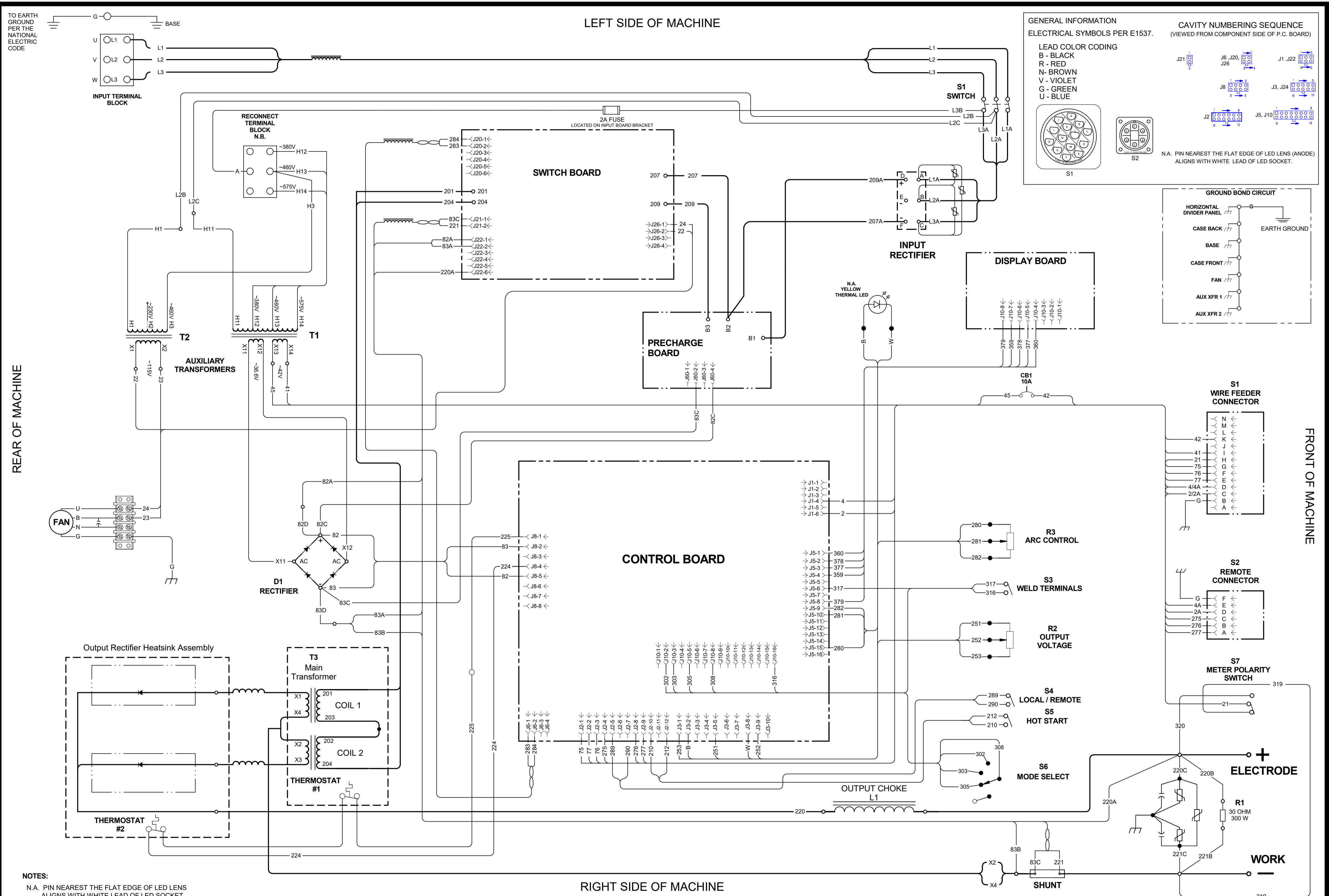

TO EARTH GROUND PER THE NATIONAL ELECTRIC CODE

LEFT SIDE OF MACHINE

GENERAL INFORMATION
ELECTRICAL SYMBOLS PER E1537.

CAVITY NUMBERING SEQUENCE
(VIEWED FROM COMPONENT SIDE OF P.C. BOARD)

LEAD COLOR CODING
B - BLACK
R - RED
N - BROWN
V - VIOLET
G - GREEN
U - BLUE

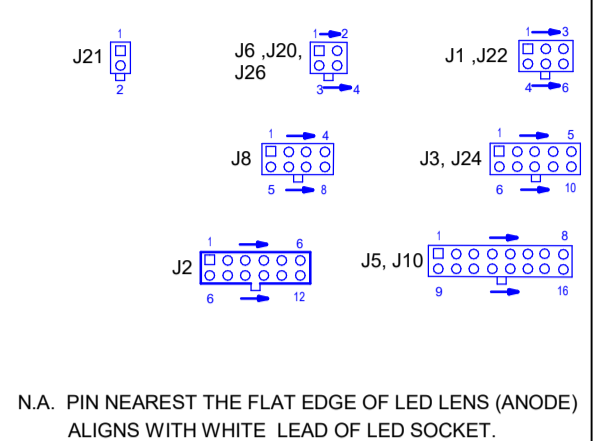
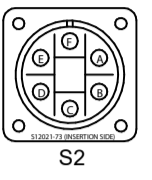
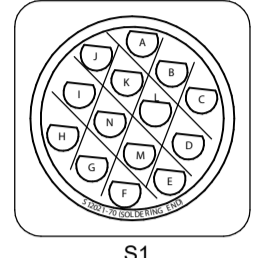

N.A. PIN NEAREST THE FLAT EDGE OF LED LENS (ANODE) ALIGNS WITH WHITE LEAD OF LED SOCKET.

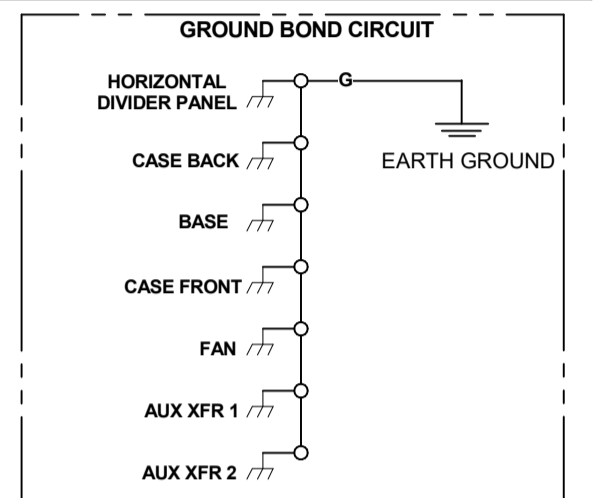

REAR OF MACHINE

FRONT OF MACHINE

RIGHT SIDE OF MACHINE

NOTES:
N.A. PIN NEAREST THE FLAT EDGE OF LED LENS ALIGNS WITH WHITE LEAD OF LED SOCKET.
N.B. PLACE "A" LEAD ON APPROPRIATE CONNECTION FOR INPUT VOLTAGE. CONNECTION SHOWN IS FOR 460 V OPERATION.

