

NEW!

Magnum[®] 250LX[™]

ACCESSORIES

Spool Gun

The Magnum 250LX spool gun is a professional grade solution for feeding small spools of aluminum and steel wire. Featuring a 1 year warranty and a 280A 60% duty cycle rating, the Magnum 250LX is a combination of durability and performance. The gun is well balanced and lightweight, and the unique oval shaped handle with finger ribs ensures both comfort and a sure grip. The Magnum 250LX is an ideal complement to the Power MIG 350MP and the Power MIG 255C.

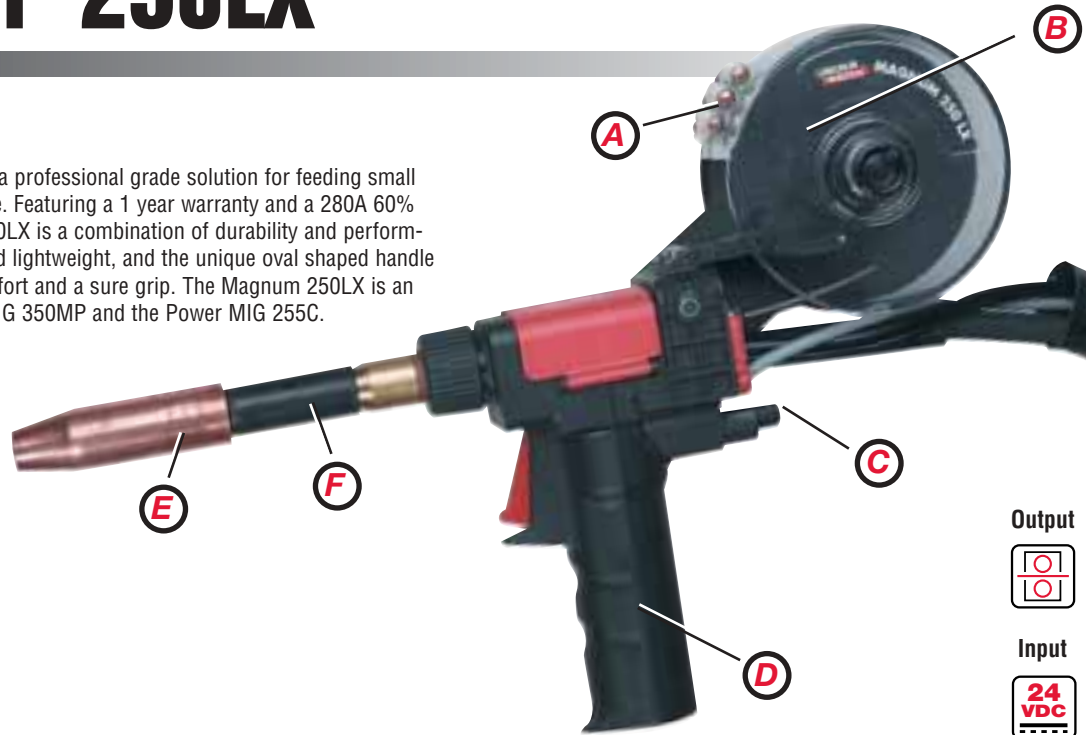

Processes
MIG, Pulsed

Output



Input



Advantage Lincoln

- A** Contact Tip Storage - Keeps spare tips conveniently located at your fingertips.
- B** Fixed Spool Brake with Independent Wire Leveler – Prevents wire tangles with no adjustments to fuss with.
- C** Multi-turn wire speed adjustment – Adjusts wire speed remotely at the gun with fine resolution.
- D** Sure grip handle – Unique shape comfortably fits the hand and provides a secure grip for this lightweight balanced gun.
- E** Standard Magnum Expendable Parts – Shares the same contact tips and nozzles as the Magnum 300 gun reducing the amount of parts needed.
- F** Replaceable Barrel – Makes replacement easy and will easily change over to future curved barrels.
- G** Large covered drive roll compartment – Opens easy and wide providing a large space to make threading wire simple.
- H** Tool-less Drive Roll Tension – Large thumbscrew makes fine adjustment of drive roll pressure effortless. Set screw allows for coarser adjustment if needed for steel.



TECHNICAL SPECIFICATIONS

Product Name	Product Number	Input Power	Rated Output Current/Duty Cycle	Wire Feed Speed Range ipm (m/min)	Wire Size Range Inches (mm)	Dimension HxWxD Inches (mm)	Net Weight Lbs. (kg)
Magnum 250LX Spool Gun	K2490-1	24V DC	CO ₂ : 300A/60% Ar: 280A/60% Ar: 200A/100%	50-800 (1.3 – 20.3)	.025 – 3/64 (0.6 - 1.2)	10.5 x 3.0 x 15.5 (266 x 76 x 394)	3 lbs. ⁽¹⁾ (1.36 kg)

⁽¹⁾ Excludes Cable.

EXPENDABLE PARTS

Description	Order Number
Contact Tips:	
.025" (0.6 mm) Contact Tip (Steel)	KP14-23
.030" (0.8 mm) Contact Tip (Steel or Aluminum)	KP14-30
.035" (0.9 mm) Contact Tip (Steel or Aluminum, Heavy Duty)	KP14H-35 ⁽¹⁾
3/64" (1.2 mm) Contact Tip (Aluminum)	KP14A-364
3/64" (1.2 mm) Contact Tip (Aluminum, Heavy Duty)	KP14AH-364 ⁽¹⁾
Gas Diffuser	KP52FN ⁽¹⁾
Fixed Nozzles:	
3/8" (9.5 mm) Gas Nozzle (Recessed)	KP23-37
1/2" (12.7 mm) Gas Nozzle (Recessed)	KP23-50 ⁽¹⁾
5/8" (15.8 mm) Gas Nozzle (Recessed)	KP23-62
3/4" (19.1 mm) Gas Nozzle (Recessed)	KP23-75
3/8" (9.5 mm) Gas Nozzle (Flush)	KP23-37F
1/2" (12.7 mm) Gas Nozzle (Flush)	KP23-50F
5/8" (15.8 mm) Gas Nozzle (Flush)	KP23-62F
3/4" (19.1 mm) Gas Nozzle (Flush)	KP23-75F
Drive Rolls:	
.025 / .035" (0.6/0.9 mm) Drive Roll (Steel)	KP2518-1
.030-.035 / 3/64" (0.8-0.9 / 1.2 mm) Drive Roll (Aluminum)	KP2518-2 ⁽¹⁾
Barrel Liner	KP2521-1 ⁽¹⁾

⁽¹⁾Included with gun.

FEATURES

- Lightweight and well-balanced.
- Standard 25 ft. (7.5 m) cable with 7-pin MS-type connector.
- See-through spool enables quick visual checks of the wire supply.
- One each .035" and 3/64" (0.9 and 1.2 mm) contact tips are included with gun.
- Feeds .025" and .035" (0.6 and 0.9 mm) steel electrode with optional drive roll.
- Recommended only for use with these power sources: Power MIG 255C and 350MP (Power MIG 255 with spool gun adapter).
- 1 Year Warranty.

WHAT'S INCLUDED

- K2490-1 Magnum 250LX Spool Gun.
- KP14H-35 .035" (0.9 mm) steel or aluminum contact tip, qty 1.
- KP14AH-364 3/64" (1.2 mm) aluminum contact tip, qty 1.
- KP52FN fixed nozzle gas diffuser for .025-3/64" (0.6-1.2 mm) wire, qty 1.
- KP23-50 1/2" recessed gas nozzle, qty 1.
- KP2518-2 aluminum drive roll for .030-.035 / 3/64" (0.8-0.9 / 1.2 mm) wire, qty 1.
- KP2521-1 barrel liner, qty 1.

GENERAL OPTIONS

Spool Gun Adapter Kit

Enables the Power MIG 255 wire feeder welder to accept the K2490-1 Magnum 250LX, K487-25 Magnum SG Spool Gun or a Prince XL Spool Gun. Includes K1738-1 Spool Gun holder.

Note: Power MIG 255C does not require adapter.
Order K2310-1



GENERAL OPTIONS

Control Cable Extension

Extend your spool gun reach with a 25 ft. (7.5 m) control cable extension. Features a 7-pin female MS-type connector on the spool gun end and a 7-pin male MS-type connector on the power source end.

Order K2519-1

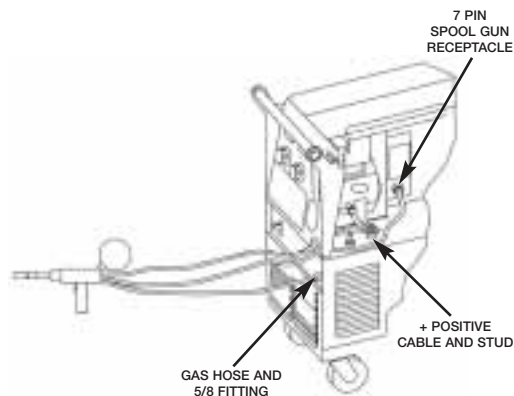
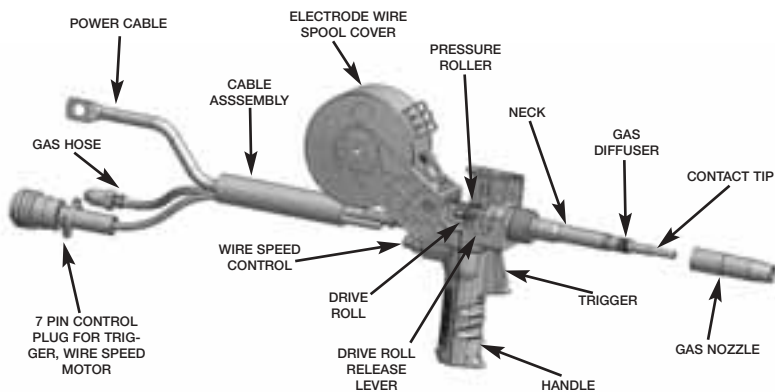

CUSTOMER ASSISTANCE POLICY

The business of The Lincoln Electric Company is manufacturing and selling high quality welding equipment, consumables, and cutting equipment. Our challenge is to meet the needs of our customers and to exceed their expectations. On occasion, purchasers may ask Lincoln Electric for advice or information about their use of our products. We respond to our customers based on the best information in our possession at that time. Lincoln Electric is not in a position to warrant or guarantee such advice, and assumes no liability, with respect to such information or advice. We expressly disclaim any warranty of any kind, including any warranty of fitness for any customer's particular purpose, with respect to such information or advice. As a matter of practical consideration, we also cannot assume any responsibility for updating or correcting any such information or advice once it has been given, nor does the provision of information or advice create, expand or alter any warranty with respect to the sale of our products.

Lincoln Electric is a responsive manufacturer, but the selection and use of specific products sold by Lincoln Electric is solely within the control of, and remains the sole responsibility of the customer. Many variables beyond the control of Lincoln Electric affect the results obtained in applying these types of fabrication methods and service requirements.

Subject to Change – This information is accurate to the best of our knowledge at the time of printing. Please refer to www.lincolnelectric.com for any updated information.